

# Pumping

Solution architectures,  
Recommended products

Introduction

December 2015

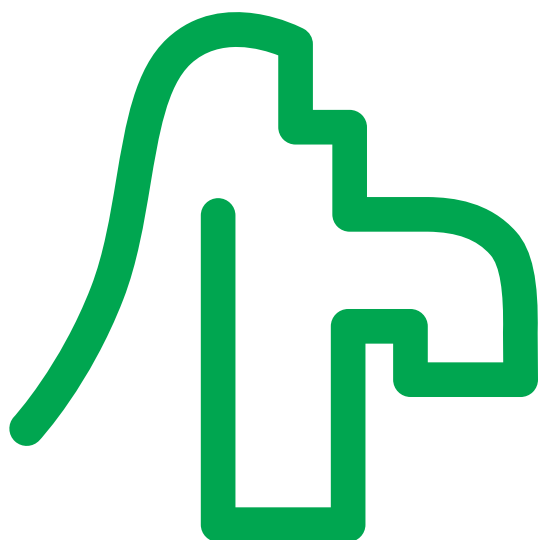

# Pumping

## Solution architectures, Recommended products

---

- **General overview** ..... 2 & 3
- **Selection guide** ..... 4 & 5
- **Booster applications: Application software libraries for booster**
  - Overview ..... 6
  - Description ..... 7
- **Single drive booster for industry & infrastructure, and buildings**
  - Presentation ..... 8
  - Architectures
    - Pumping / Booster Single Drive / CANopen / Magelis SCU Controller ..... 9
    - Pumping / Booster Single Drive / Hardwired / Modicon M241 Logic controller ..... 10
    - Pumping / Booster Single Drive / CANopen / Modicon M241 Logic controller ..... 11
- **Multi drive booster for industry & infrastructure, and buildings**
  - Presentation ..... 12
  - Architectures
    - Pumping / Booster Multi Drive / Modbus SL / Modicon M241 Logic controller ..... 13
    - Pumping / Booster Multi Drive / CANopen / Modicon M241 Logic controller ..... 14
    - Pumping / Booster Multi Drive / EtherNet/IP / Modicon M251 Logic controller ..... 15
    - Pumping / Booster / Multi Drive / Modbus SL / Magelis SCU Controller ..... 16
    - Pumping / Booster / Multi Drive / CANopen / Magelis SCU Controller ..... 17
- **Single drive booster for buildings with BMS (BACnet or LonWorks connection)**
  - Presentation ..... 18
  - Architecture
    - Pumping / Booster Single Drive / Hardwired / Modicon M172 performance Logic controller ..... 19
- **Multi drive booster for buildings with BMS (BACnet or LonWorks connection)**
  - Presentation ..... 20
  - Architecture
    - Pumping / Booster Multi Drive / Hardwired / Modicon M172 performance Logic controller ..... 21
- **Other pumping applications, based on Altivar Process ATV600 Variable speed drive**
  - Presentation ..... 22
  - Architectures
    - Pumping / Single drive / Hardwired / Altivar Process ATV600 V.S.D. .... 23
    - Pumping / Multi drive / Ethernet / Altivar Process ATV600 V.S.D. .... 23
- **Service & support: Stages in the product life cycle**
  - Design ..... 24
  - Build ..... 24
  - Operate ..... 25
  - Improve ..... 25

# Pumping

## Solution architectures – Recommended products

### General overview

Schneider Electric expands pumping automation offer to facilitate engineering of smart, future-ready pumping systems



#### New, pumping-dedicated products help you to optimise pumping system performance

Schneider Electric, the global specialist in energy management and automation, has just added new **Altivar™**, **Modicon™**, and **Magelis™** smart products to its automation portfolio. This makes new pumping-specific functionalities available for a wide range of applications, including industry, infrastructure, and buildings.

The new devices, when combined with **MachineStruxure™** automation solutions, help you build and manage flexible, connected, and efficient pumping systems.

Schneider Electric's smart pumping control solutions fit a wide range of applications, including water & wastewater, buildings, oil & gas, and food & beverage.

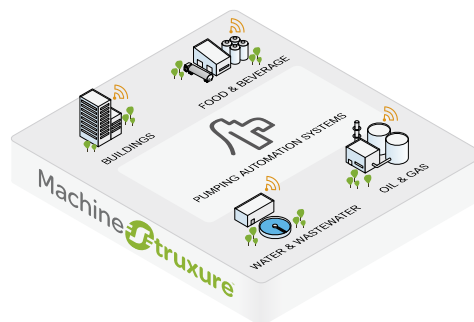

#### More flexibility for easier customisation

MachineStruxure solutions, including hardware, software, the full scope of Schneider Electric industry-specific know-how, and services, enable building tailor-made pumping systems faster and easier.

Smart products from Schneider Electric's comprehensive catalogue, such as the **Altivar™ Process ATV600**, and solutions based on logic controllers **Modicon M221, M241, M251, and M171/M172**, and the **Magelis SCU HMI** controller, facilitate customisation through embedded pumping-related functionalities.

Expert support throughout the life cycle of a pumping system, from design and engineering to on-site maintenance services provided by Schneider Electric, enable you to optimise pumping system performance and increase business efficiency.

#### Greater efficiency for better system performance

Pre-developed Tested, Validated, and Documented Architectures (TVDAs) included in MachineStruxure offer help original equipment manufacturers engineer pumping solutions more easily and more quickly.

Ready-to-use Application Function Blocks enable easy implementation of pumping-specific functions such as pump stage and de-stage, cavitation protection, auxiliary pumps, and others.

Thanks to comprehensive software libraries, pumping systems based on MachineStruxure feature energy-efficient solutions for reducing energy consumption and optimising costs of operations.

# Pumping

## Solution architectures – Recommended products

### General overview



#### Increased connectivity for a full picture of operations

The new, smart, connected products help collect and manage real-time information across the pumping system to acquire comprehensive data on system performance. An embedded web server enables end users to remotely view and analyse data via Internet-connected devices such as smartphones or laptops, at any time and place.

The updated portfolio also simplifies the integration of pumping systems with existing infrastructure, such as building and manufacturing management systems. This makes it easier to allocate resources and optimise system performance.

#### Select the intelligent and efficient automation solution for your booster station in industry & infrastructure, and buildings



##### Single drive booster



Cost effective, simpler solution for smaller booster









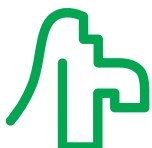

##### Multi drive booster

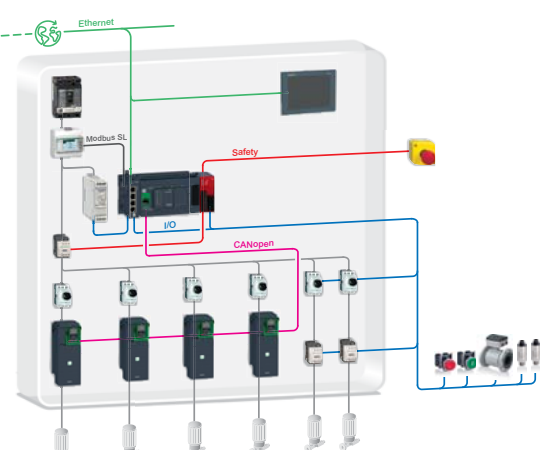
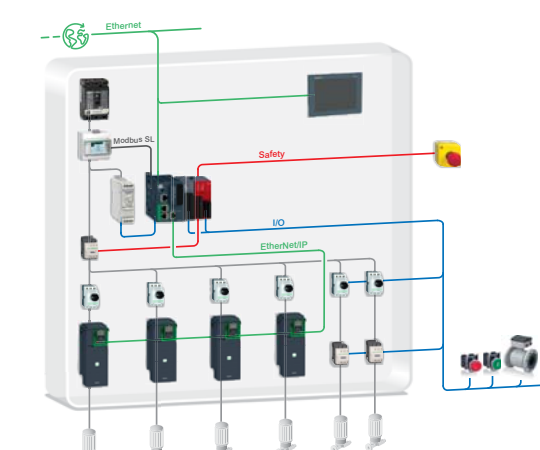
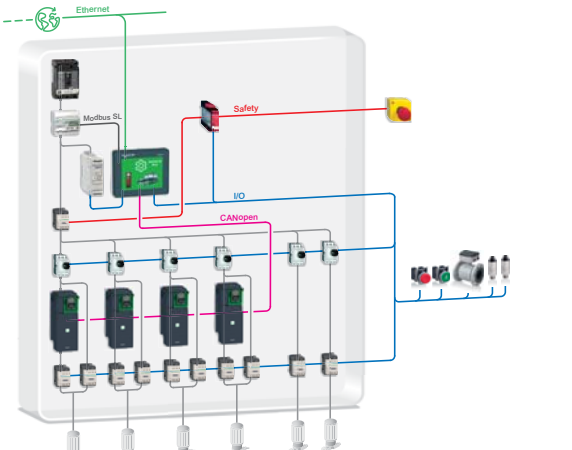
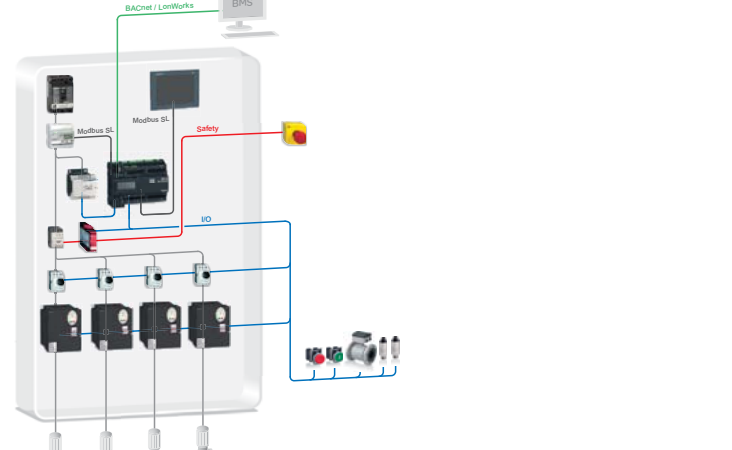
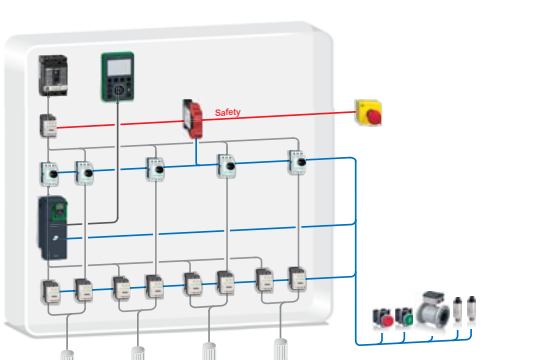
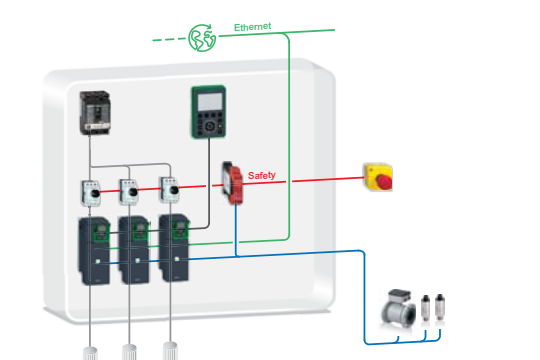

More energy efficient system providing a higher level of protection for the entire pump and pipe system









For more information about the smart pumping control solutions, please visit [www.schneider-electric.com/pumping](http://www.schneider-electric.com/pumping)

Solution architectures	Industry & Infrastructure, Buildings		Buildings with BMS (BACnet, LonWorks)	
<p>Solution architectures and AFBs for booster applications</p>	 <p>Based on <b>Modicon M241</b> Logic controller, in TVDA with SoMachine software                      + <b>Application software libraries</b> (including AFBs)                      &gt; Ethernet, CANopen, Modbus                      &gt; Single drive or Multi drive</p>	 <p>Based on <b>Modicon M251</b> Logic controller, in TVDA with SoMachine software                      + <b>Application software libraries</b> (including AFBs)                      &gt; Ethernet, CANopen, Modbus                      &gt; Single drive or Multi drive</p>	 <p>Based on <b>Magelis SCU</b> HMI controller, in TVDA with SoMachine software                      + <b>Application software libraries</b> (including AFBs)                      &gt; Ethernet, CANopen, Modbus                      &gt; Single drive or Multi drive</p>	 <p>Based on <b>Modicon M172 performance</b> Logic controller, in TVDA with SoMachine HVAC software                      + <b>Application software libraries</b> (including AFBs)                      &gt; BACnet, LonWorks, Modbus                      &gt; Single drive or Multi drive</p>
<p>Solution architectures with embedded functions for other pumping systems:</p> <ul style="list-style-type: none"> <li>&gt; Multipumps,</li> <li>&gt; Boosters,</li> <li>&gt; Level control,</li> <li>&gt; Circulators,</li> <li>&gt; Others</li> </ul>	 <p>Based on <b>Altitvar Process ATV600</b> variable speed drives, + <b>Application software function</b> embedded in Altitvar Process ATV600 V.S.D.                      &gt; Ethernet, Modbus                      &gt; Single drive</p>	 <p>Based on <b>Altitvar Process ATV600</b> variable speed drives, + <b>Application software function</b> embedded in Altitvar Process ATV600 V.S.D.                      &gt; Ethernet, Modbus                      &gt; Multi drive</p>		
<p>Product approach in pumping systems</p>	 <p>&gt; <b>Modicon M221</b> Logic controller                      + SoMachine Basic software                      &gt; Ethernet, Modbus</p>	 <p>&gt; <b>Modicon M241</b> Logic controller                      + SoMachine software                      &gt; Ethernet, CANopen, Modbus</p>	 <p>&gt; <b>Modicon M251</b> Logic controller                      + SoMachine software                      &gt; Ethernet, CANopen, Modbus</p>	 <p>&gt; <b>Magelis SCU</b> HMI controller                      + SoMachine software                      &gt; Ethernet, CANopen, Modbus</p>  <p>&gt; <b>Altitvar Process drive ATV600</b> V.S.D.                      + SoMove software                      &gt; Ethernet, Modbus</p>  <p>&gt; <b>Modicon M172 performance</b> Logic controller                      + SoMachine HVAC software                      &gt; BACnet, LonWorks, Modbus</p>  <p>&gt; <b>PLCs</b> (Modicon M241/M251/M221 Logic controllers, Magelis SCU HMI controller) with <b>gateway</b> to BACnet or LonWorks</p>

The TVDAs (Tested Validated Documented Architectures) and the AFBs (Application Function Blocks) are available by using the following programming softwares: SoMachine, SoMachine HVAC

AFBs provided in SoMachine's Application software library

-  Pump stage and de-stage,
-  PID,  Booster working mode,
-  Friction loss compensation,
-  Auxiliary pump,
-  Cavitation protection

# Pumping

Solution architectures – Recommended products

Booster applications

Application software libraries for booster stations

Application software libraries for booster stations

## Overview

Shorten your engineering time with extensively tested application software! SoMachine™ libraries provide software functionality in the form of ready-to-use function blocks (AFBs = Application Function Blocks), which are supplied for many basic common automation tasks and machine functionalities. They can be easily configured, customized, and implemented in your machine program.

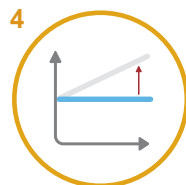
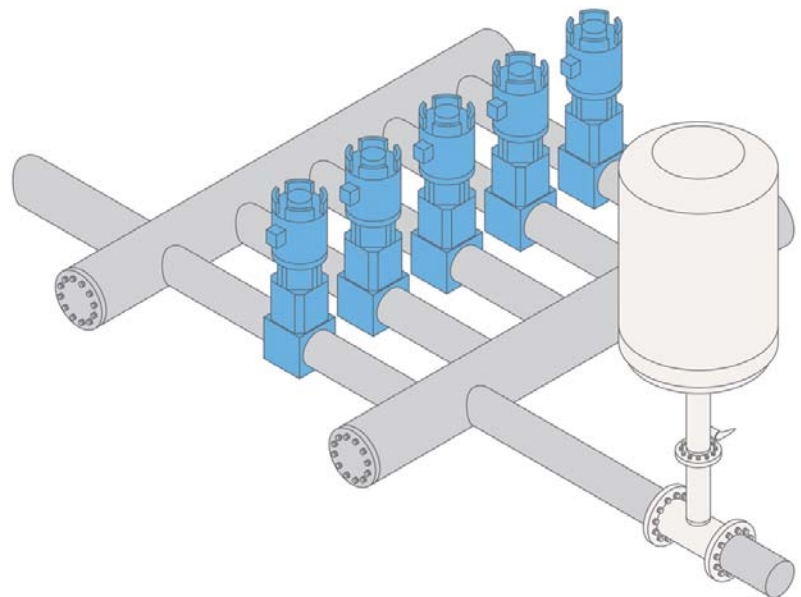
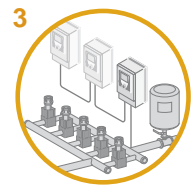
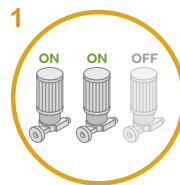

Discover the smart pump-specific functions for more system's energy efficiency, operational reliability, and availability:

- 1 – Pump stage and de-stage
- 2 – PID
- 3 – Booster working mode
- 4 – Friction loss compensation
- 5 – Auxiliary pump
- 6 – Cavitation protection

#### Application software libraries for booster stations

#### Description

##### 1 – Pump stage and de-stage

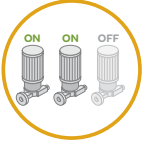

##### Optimize booster system operation by switching pumps

The pump stage and de-stage function switch is a combination of fixed and variable speed pumps used to maintain a constant pressure in a booster system.

##### Benefits

- > Maintains the required pressure by performing switching between the pumps available in the system
- > Makes the system energy efficient by making the operational combination of pumps in such a way that the pumps operated by drives are given priority
- > Ensures a smooth operation by checking the availability of the pumps and, if a faulted pump is detected, changing over to next available pump

##### 2 – PID



##### Maintain a constant pressure by adapting setpoints

The PID function adjusts the setpoint of the variable speed drives to maintain a constant pressure in a booster system on the basis of pressure value and optional flow value.

##### Benefits

- > Maintains the required pressure by adjusting the setpoint of the frequency of the variable speed drive
- > Generates alarms in case of deviation of limits
- > Ensures a smooth operation by maintaining the setpoints curve to avoid damping

##### 3 – Booster working mode

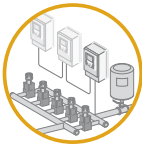

##### Operate the system in an optimized method

The booster working mode function allows the OEM to select the best working mode for the booster system in multidrive or single drive with multi or single lead.

##### Benefits

- > Multi drive function provides the best energy-efficient systems along with the highest level of pump protection. Easy-to-maintain systems. Modular and adaptable. Better ROI and extended life of pump. Each pump is connected to an individual drive
- > Single drive, multilead function provides a cost-optimized solution using contractors to manage multiple pumps with a single drive. Pump selection is made by operating hours or predefined priority
- > Single drive, single-lead function provides just enough of a cost solution with just enough pump protection and limited energy efficiency. One pump is connected to the only drive in the system

##### 4 – Friction loss compensation

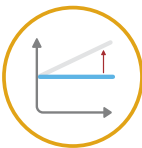

##### Ensure a linear pressure in the booster system

This function compensates the friction lost by adapting the pressure setpoint according to the number of running pumps or the flow value (optional) in the discharge side.

##### Benefits

- > Energy saving by adapting the pressure setpoint according to the system curve of the pipe application
- > Easy and flexible adaptation of the system curve based on your individual application
- > With the adaptation of the pressure setpoints this function ensures that the pumps are operating in an optimized state

##### 5 – Auxiliary pump



##### Operating auxiliary-speed pumps in a booster system

The function is controlling the auxiliary pump to maintain the water pressure during sleep mode (no flow / very low flow).

##### Benefits

- > Detect conditions where an auxiliary pump needs to be operated
- > Ensure optimized pump efficiency by switching auxiliary pump to maintain pressure in the system
- > Increase the energy efficiency of the system by operating smaller pumps to maintain lower flow

##### 6 – Cavitation protection



##### Monitor and protect the pump against cavitations

This function avoids the operation of the pump in a cavitation situation by stopping the pump.

##### Benefits

- > Longer operating life of the pump by ensuring that the pump is not operating in cavitation
- > Generates alarms in case of detection of cavitation in the system
- > With the adaptation of the setpoints, this function ensures that the pumps are operating in an optimized state

# Pumping

## Solution architectures – Recommended products

### Booster applications

#### Single drive booster for industry & infrastructure, and buildings

#### Single drive booster for industry & infrastructure, and buildings



#### Cost effective, simpler solution for smaller booster

##### Challenges

##### Your business issues are unique

You need to develop a cost efficient booster application for industry & infrastructure, and buildings. You are determined to offer an easy-to-use system with diagnostics.

##### Solution description

Dedicated to simple and standard booster in industry & infrastructure. This is the first step towards automation from traditional relay architectures. With Magelis SCU Controller, this architecture provides very cost efficient solution. Single drive can be used in single or multi drive mode.

##### Value proposition

- > Do not start from the scratch, use TVDAs, to start the application
- > Do not program: use pre-developed and easily configurable functions and templates block to develop your application
- > A complete and cost optimized solution
- > Embedded pumping functions like friction loss compensation, pump stage and de-stage, PID, and others
- > Increase flexibility with HMI controller Magelis SCU, and Modicon M241 logic controller
- > Reduced panel size
- > Switching on and off multiple pumps with a single drive to optimize the energy consumption
- > Built-in display provides monitoring capabilities which suits your application
- > Connect everywhere: built-in multiple connectivity options provides seamless connectivity to other control and monitoring systems. The embedded web server provides the possibility for remote access through web visualization by smart phones and internet

##### Differentiation

- > Capable of managing multiple pumps using one drive
- > Maintains the pressure constant in the system with PID, pump stage and de-stage
- > Diagnostic features for easy maintenance
- > Embedded booster and pumps protection using features like cavitation protection
- > Operates smaller pumps (auxiliary pumps) to maintain lower flow requirement
- > Compact size of the controller and drives reduces the panel size

# Pumping

Solution architectures – Recommended products

Booster applications

Single drive booster for industry & infrastructure, and buildings

Single drive booster for industry & infrastructure, and buildings

Architecture

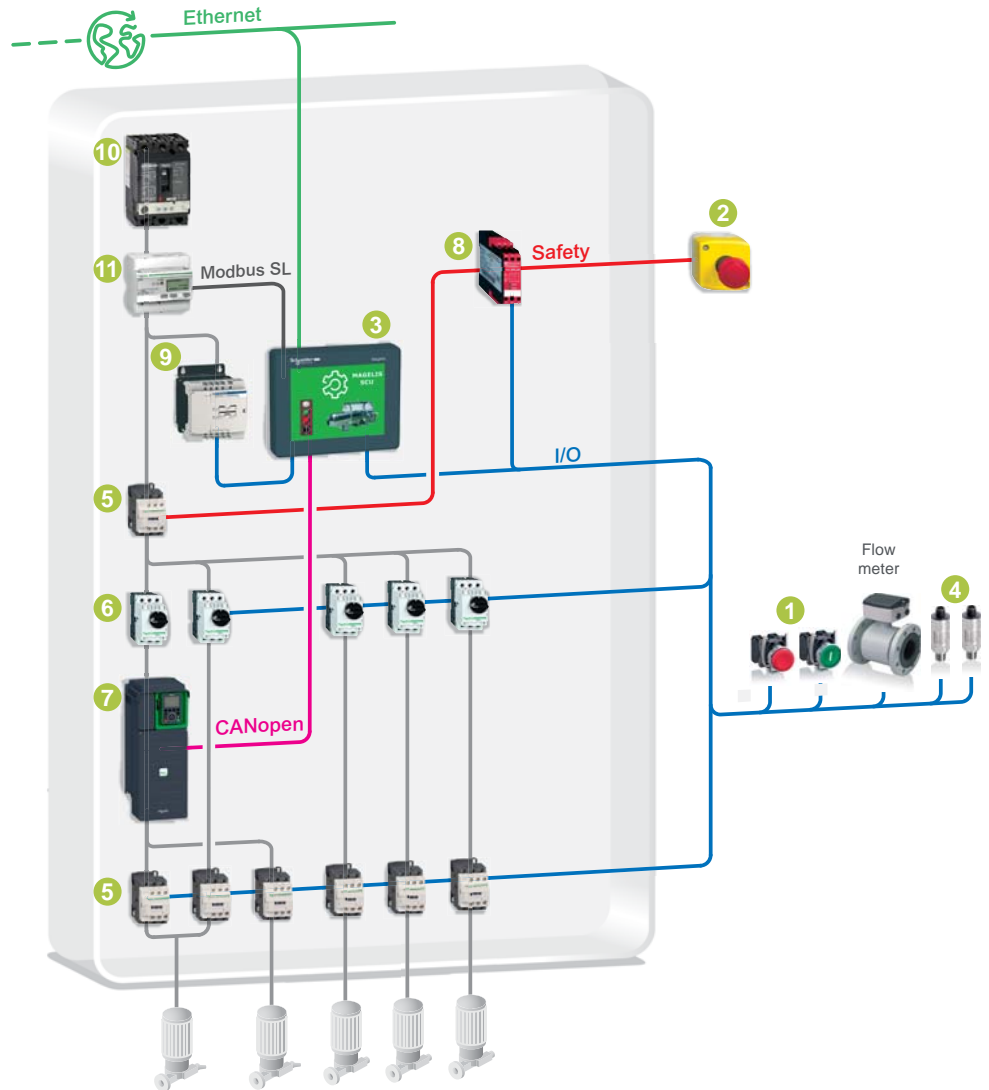

Pumping / Booster Single Drive / CANopen / Magelis SCU Controller

**Solution breakdown**

> Pushbuttons, Switches, Pilot Lights & Joysticks	<b>1</b> Harmony XB5 Ø 22 mm plastic pushbuttons, switches, pilot lights <b>2</b> Harmony XB4 Ø 22 mm metal pushbuttons, switches, pilot light
> Boxes, Cabling & Interfaces	<b>2</b> Harmony XALK Emergency stop push button
> HMI (Terminals and Industrial PC)	<b>3</b> Magelis SCU Controller
> Sensors & RFID System	<b>4</b> OsiSense XMLP Pressure sensor
> Motor Starters	<b>5</b> TeSys D Contactor and reversing contactor <b>6</b> TeSys GV2P Magnetic motor circuit breaker (rotary knob)
> Drives & Soft Starters	<b>7</b> Altivar Process ATV600 Variable speed drive
> PAC, PLC & other Controllers	<b>8</b> Preventa XPS Safety module
> Power Supplies & Transformers	<b>9</b> Phaseo Switch mode power supply
> Power Circuit breakers & Switches	<b>10</b> Compact NSX Circuit breaker
> Power & Energy Monitoring System	<b>11</b> Acti 9 iEM3000 series energy meter

# Pumping

Solution architectures – Recommended products

Booster applications

Single drive booster for industry & infrastructure, and buildings

Single drive booster for industry & infrastructure, and buildings

Architecture

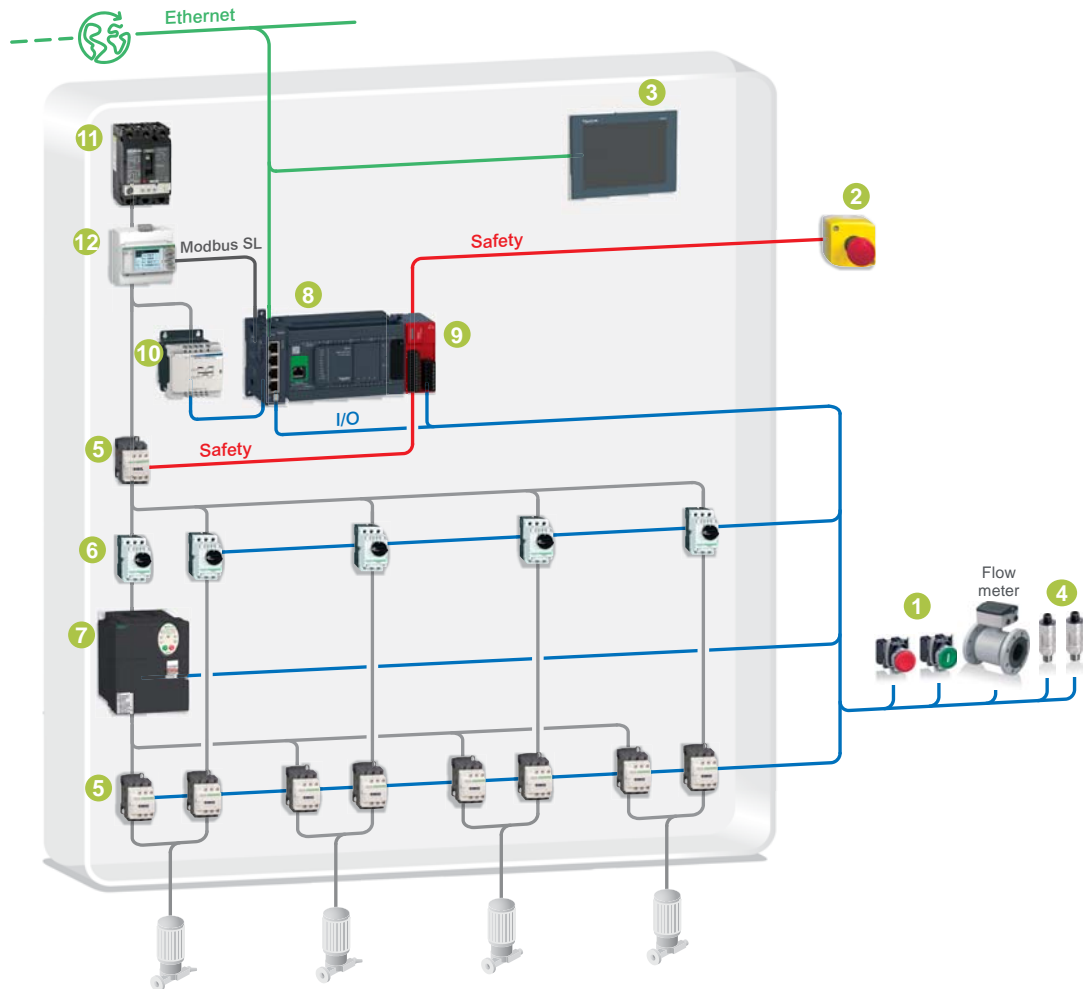

## Pumping / Booster Single Drive / Hardwired / Modicon M241 Logic controller

### Solution breakdown

> Pushbuttons, Switches, Pilot Lights & Joysticks	<b>1</b> Harmony XB5 Ø 22 mm plastic pushbuttons, switches, pilot lights Harmony XB4 Ø 22 mm metal pushbuttons, switches, pilot light
> Boxes, Cabling & Interfaces	<b>2</b> Harmony XALK Emergency stop push button
> HMI (Terminals and Industrial PC)	<b>3</b> Magelis HMISTU Small panel
> Sensors & RFID System	<b>4</b> OsiSense XMLP Pressure sensor
> Motor Starters	<b>5</b> TeSys D Contactor and reversing contactor <b>6</b> TeSys GV2P Magnetic motor circuit breaker (rotary knob)
> Drives & Soft Starters	<b>7</b> Altivar 212 Variable speed drive
> PAC, PLC & other Controllers	<b>8</b> Modicon M241 Logic controller + Modicon TM4 Ethernet switch module <b>9</b> Modicon TM3 functional safety module
> Power Supplies & Transformers	<b>10</b> Phaseo Switch mode power supply
> Power Circuit breakers & Switches	<b>11</b> Compact NSX Circuit breaker
> Power & Energy Monitoring System	<b>12</b> Acti 9 iEM3000 series energy meter

# Pumping

Solution architectures – Recommended products

Booster applications

Single drive booster for industry & infrastructure, and buildings

Single drive booster for industry & infrastructure, and buildings

Architecture

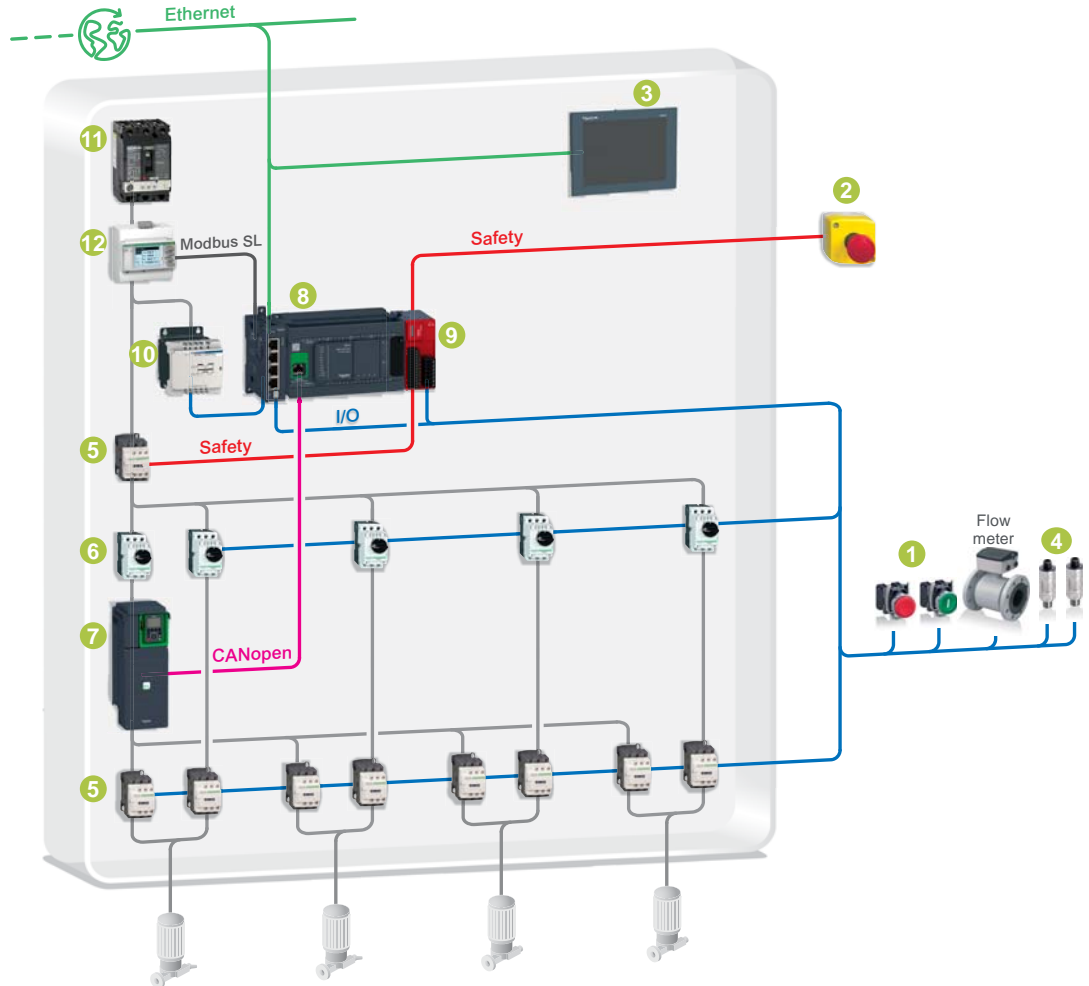

## Pumping / Booster Single Drive / CANopen / Modicon M241 Logic controller

### Solution breakdown

> Pushbuttons, Switches, Pilot Lights & Joysticks	1 Harmony XB5 Ø 22 mm plastic pushbuttons, switches, pilot lights Harmony XB4 Ø 22 mm metal pushbuttons, switches, pilot light
> Boxes, Cabling & Interfaces	2 Harmony XALK Emergency stop push button
> HMI (Terminals and Industrial PC)	3 Magelis HMISTU Small panel
> Sensors & RFID System	4 OsiSense XMLP Pressure sensor
> Motor Starters	5 TeSys D Contactor and reversing contactor 6 TeSys GV2P Magnetic motor circuit breaker (rotary knob)
> Drives & Soft Starters	7 Altivar Process ATV600 Variable speed drive
> PAC, PLC & other Controllers	8 Modicon M241 Logic controller + Modicon TM4 Ethernet switch module 9 Modicon TM3 functional safety module
> Power Supplies & Transformers	10 Phaseo Switch mode power supply
> Power Circuit breakers & Switches	11 Compact NSX Circuit breaker
> Power & Energy Monitoring System	12 Acti 9 iEM3000 series energy meter

# Pumping

## Solution architectures – Recommended products

### Booster applications

### Multi drive booster for industry & infrastructure, and buildings

#### Multi drive booster for industry & infrastructure, and buildings



#### More energy efficient system providing a higher level of protection for the entire pump and pipe system

##### Challenges

##### Your business issues are unique

You need to develop a booster for industry & infrastructure with higher level of functionalities, diagnostics, and protection with flexible and scalable I/Os. Flexibility in connectivity is a key issue. For you, energy efficient system is very important as your customer is focusing on Energy optimization.

##### Solution description

A powerful solution for Boosters with multiple pumps requiring maximum flexibility and scalability plus higher level of functionality. Flexibility to connect to different systems is one of the key features. A combination of power meters, drives, and energy efficiency related functions makes the system efficient.

##### Value proposition

- > Do not start from the scratch, use TVDAs, to start the application
- > Do not program: use pre-developed and easily configurable Macro function block to develop your application
- > A complete and cost optimized solution
- > Embedded pumping functions like cavitation protection, pump stage and de-stage, PID, and others
- > Increase scalability with Modicon M251 and Modicon M241 Logic controllers, and Magelis SCU Controller using wide range of I/Os
- > Improve cost-efficiency with built-in display of Magelis SCU Controller
- > Connect everywhere: built-in multiple connectivity options provides seamless connectivity to the other control and monitoring systems. The embedded web server provides the possibility for remote access through web visualization by smart phones and internet

##### Differentiation

- > Multiple pump management for a combination of pumps controlled by a variable speed drive or direct online starter
- > Design-in energy efficiency while maintaining performance
- > Maintains pressure constant in the system with PID, pump stage and de-stage related functions
- > Advanced diagnostics for each pump for easy maintenance
- > Embedded booster and pumps protection using features like cavitation protection function
- > Operates smaller pumps (auxiliary pumps) to maintain lower flow requirement

# Pumping

## Solution architectures – Recommended products

Booster applications

Multi drive booster for industry & infrastructure, and buildings

Multi drive booster for industry & infrastructure, and buildings

Architecture

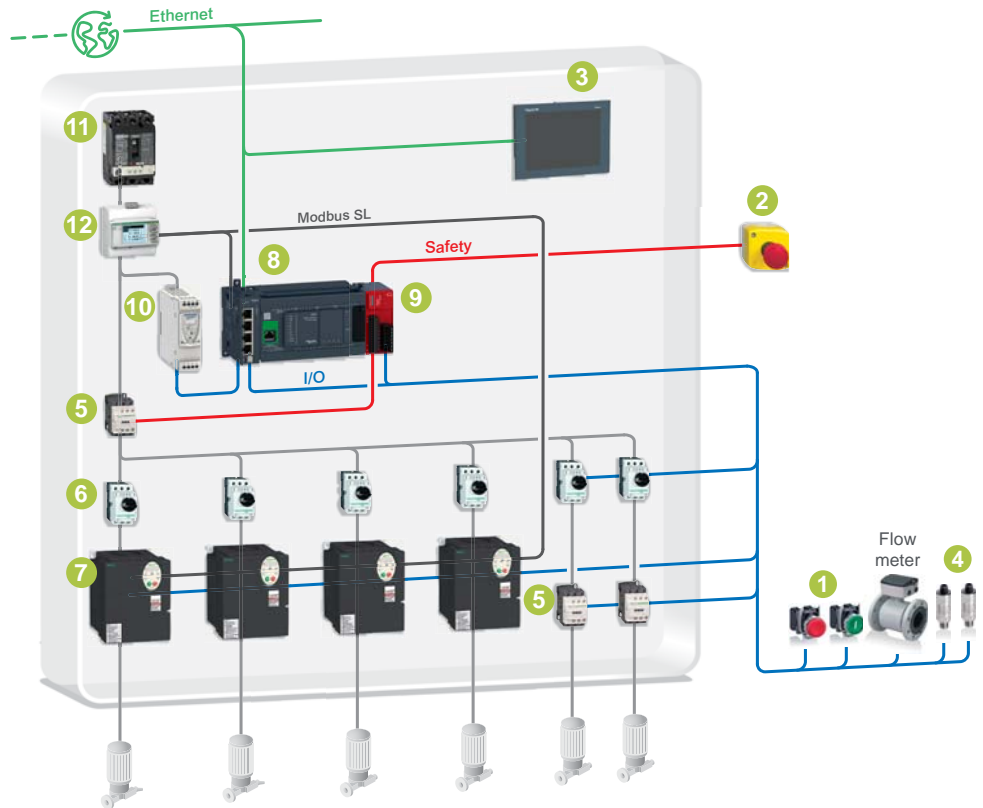

### Pumping / Booster Multi Drive / Modbus SL / Modicon M241 Logic controller

#### Solution breakdown

> Pushbuttons, Switches, Pilot Lights & Joysticks	<b>1</b> Harmony XB5 Ø 22 mm plastic pushbuttons, switches, pilot lights <b>1</b> Harmony XB4 Ø 22 mm metal pushbuttons, switches, pilot light
> Boxes, Cabling & Interfaces	<b>2</b> Harmony XALK Emergency stop push button
> HMI (Terminals and Industrial PC)	<b>3</b> Magelis HMISTU Small panel
> Sensors & RFID System	<b>4</b> OsiSense XMLP Pressure sensor
> Motor Starters	<b>5</b> TeSys D Contactor and reversing contactor
> Drives & Soft Starters	<b>6</b> TeSys GV2P Magnetic motor circuit breaker (rotary knob)
> PAC, PLC & other Controllers	<b>7</b> Altivar 212 Variable speed drive
> Power Supplies & Transformers	<b>8</b> Modicon M241 Logic controller + Modicon TM4 Ethernet switch module
> Power Circuit breakers & Switches	<b>9</b> Modicon TM3 functional safety module
> Power & Energy Monitoring System	<b>10</b> Phaseo Switch mode power supply
	<b>11</b> Compact NSX Circuit breaker
	<b>12</b> Acti 9 iEM3000 series energy meter

# Pumping

Solution architectures – Recommended products

Booster applications

Multi drive booster for industry & infrastructure, and buildings

Multi drive booster for industry & infrastructure, and buildings

Architecture

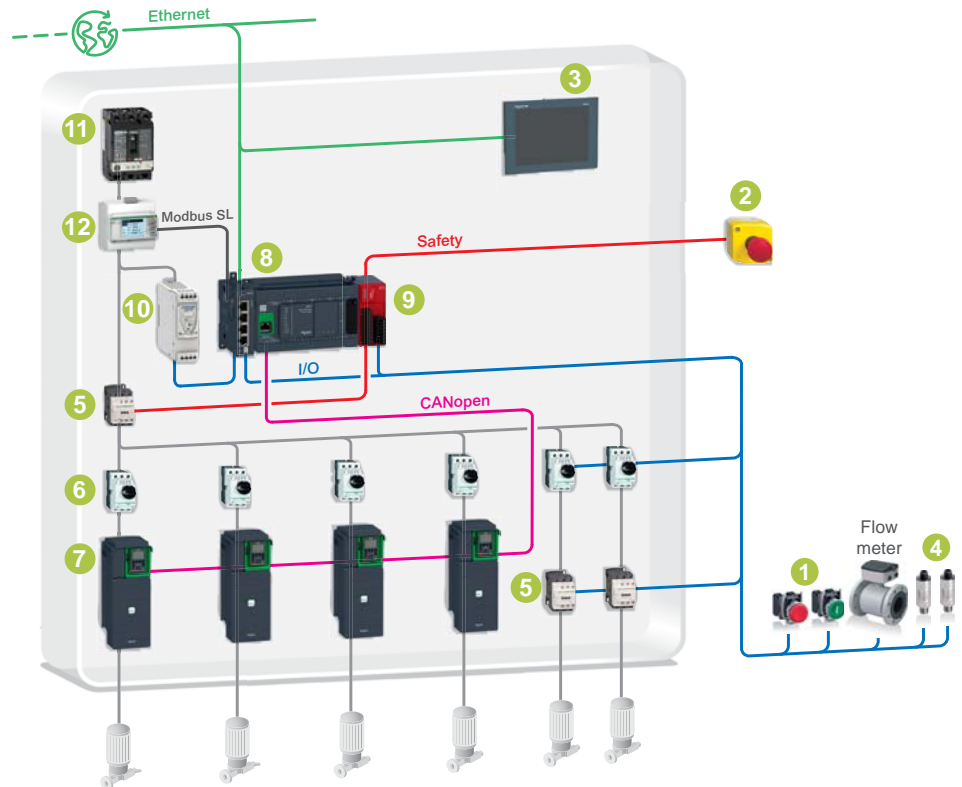

### Pumping / Booster Multi Drive / CANopen / Modicon M241 Logic controller

#### Solution breakdown

> Pushbuttons, Switches, Pilot Lights & Joysticks	<b>1</b> Harmony XB5 Ø 22 mm plastic pushbuttons, switches, pilot lights <b>Harmony XB4 Ø 22 mm metal pushbuttons, switches, pilot light</b>
> Boxes, Cabling & Interfaces	<b>2</b> Harmony XALK Emergency stop push button
> HMI (Terminals and Industrial PC)	<b>3</b> Magelis HMISTU Small panel
> Sensors & RFID System	<b>4</b> OsiSense XMLP Pressure sensor
> Motor Starters	<b>5</b> TeSys D Contactor and reversing contactor
	<b>6</b> TeSys GV2P Magnetic motor circuit breaker (rotary knob)
> Drives & Soft Starters	<b>7</b> Altivar Process ATV600 Variable speed drive
> PAC, PLC & other Controllers	<b>8</b> Modicon M241 Logic controller + Modicon TM4 Ethernet switch module
	<b>9</b> Modicon TM3 functional safety module
> Power Supplies & Transformers	<b>10</b> Phaseo Switch mode power supply
> Power Circuit breakers & Switches	<b>11</b> Compact NSX Circuit breaker
> Power & Energy Monitoring System	<b>12</b> Acti 9 IEM3000 series energy meter

# Pumping

Solution architectures – Recommended products

Booster applications

Multi drive booster for industry & infrastructure, and buildings

Multi drive booster for industry & infrastructure, and buildings

Architecture

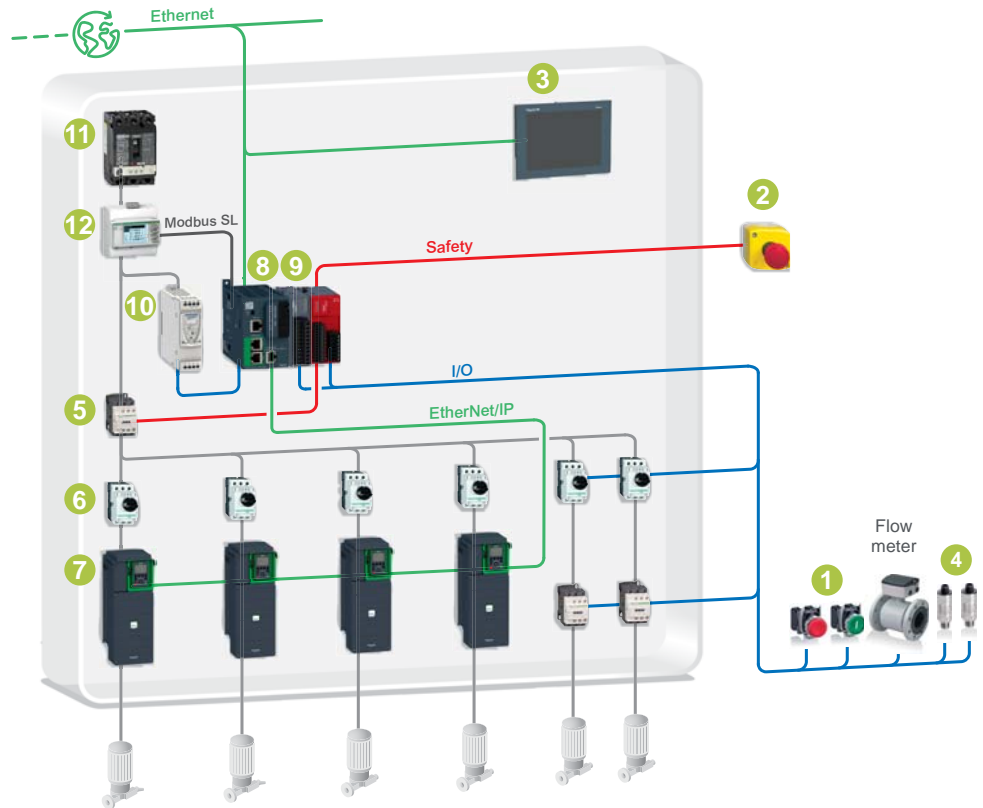

**Pumping / Booster Multi Drive / EtherNet/IP / Modicon M251 Logic controller**

**Solution breakdown**

> Pushbuttons, Switches, Pilot Lights & Joysticks	<b>1</b> Harmony XB5 Ø 22 mm plastic pushbuttons, switches, pilot lights <b>1</b> Harmony XB4 Ø 22 mm metal pushbuttons, switches, pilot light
> Boxes, Cabling & Interfaces	<b>2</b> Harmony XALK Emergency stop push button
> HMI (Terminals and Industrial PC)	<b>3</b> Magelis HMISTU Small panel
> Sensors & RFID System	<b>4</b> OsiSense XMLP Pressure sensor
> Motor Starters	<b>5</b> TeSys D Contactor and reversing contactor <b>6</b> TeSys GV2P Magnetic motor circuit breaker (rotary knob)
> Drives & Soft Starters	<b>7</b> Altivar Process ATV600 Variable speed drive
> PAC, PLC & other Controllers	<b>8</b> Modicon M251 Logic controller <b>9</b> Modicon TM3 Expansion I/O module and functional safety module
> Power Supplies & Transformers	<b>10</b> Phaseo Switch mode power supply
> Power Circuit breakers & Switches	<b>11</b> Compact NSX Circuit breaker
> Power & Energy Monitoring System	<b>12</b> Acti 9 iEM3000 series energy meter

# Pumping

Solution architectures – Recommended products

Booster applications

Multi drive booster for industry & infrastructure, and buildings

Multi drive booster for industry & infrastructure, and buildings

Architecture

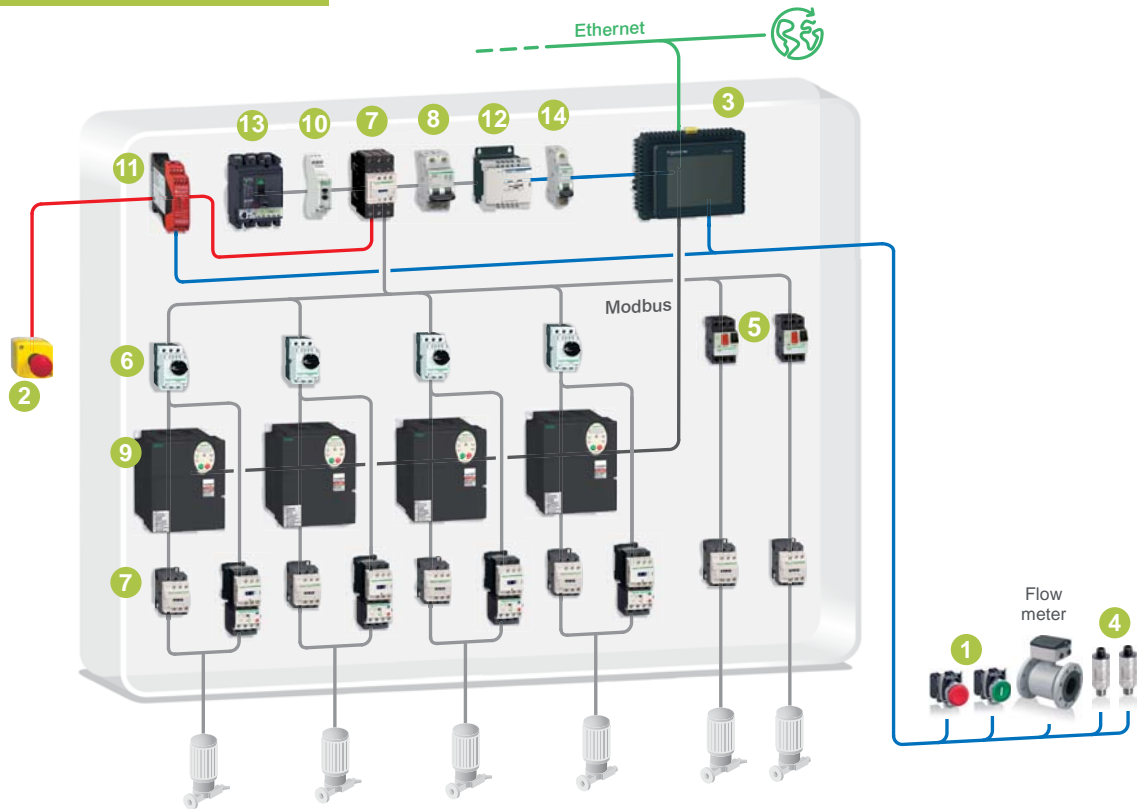

*Pumping / Booster / Multi Drive / Modbus SL / Magelis SCU Controller*

**Solution breakdown**

> Pushbuttons, Switches, Pilot Lights & Joysticks	<b>1</b> Harmony XB5 Ø 22 mm plastic pushbuttons, switches, pilot lights <b>1</b> Harmony XB4 Ø 22 mm metal pushbuttons, switches, pilot light
> Boxes, Cabling & Interfaces	<b>2</b> Harmony XALK Emergency stop push button
> HMI (Terminals and Industrial PC)	<b>3</b> Magelis SCU Controller
> Sensors & RFID System	<b>4</b> OsiSense XMLP Pressure sensor
> Motor Starters	<b>5</b> TeSys GV2M Magnetic motor circuit breaker
	<b>6</b> TeSys GV2P Magnetic motor circuit breaker (rotary knob)
	<b>7</b> TeSys D Contactor and reversing contactor
> Drives & Soft Starters	<b>8</b> C60L-MA Modular circuit breaker
	<b>9</b> Altivar 212 Variable speed drive
> Interface, Measurement & Control Relays	<b>10</b> Zelio control phase sequence
> PAC, PLC & other Controllers	<b>11</b> Preventa XPS Safety module
> Power Supplies & Transformers	<b>12</b> Phaseo Switch mode power supply
> Power Circuit breakers & Switches	<b>13</b> Compact NSX Circuit breaker
> DIN Rail Modular Devices	<b>14</b> ACTI 9-C60 Miniature circuit breaker

# Pumping

Solution architectures – Recommended products

Booster applications

Multi drive booster for industry & infrastructure, and buildings

Multi drive booster for industry & infrastructure, and buildings

Architecture

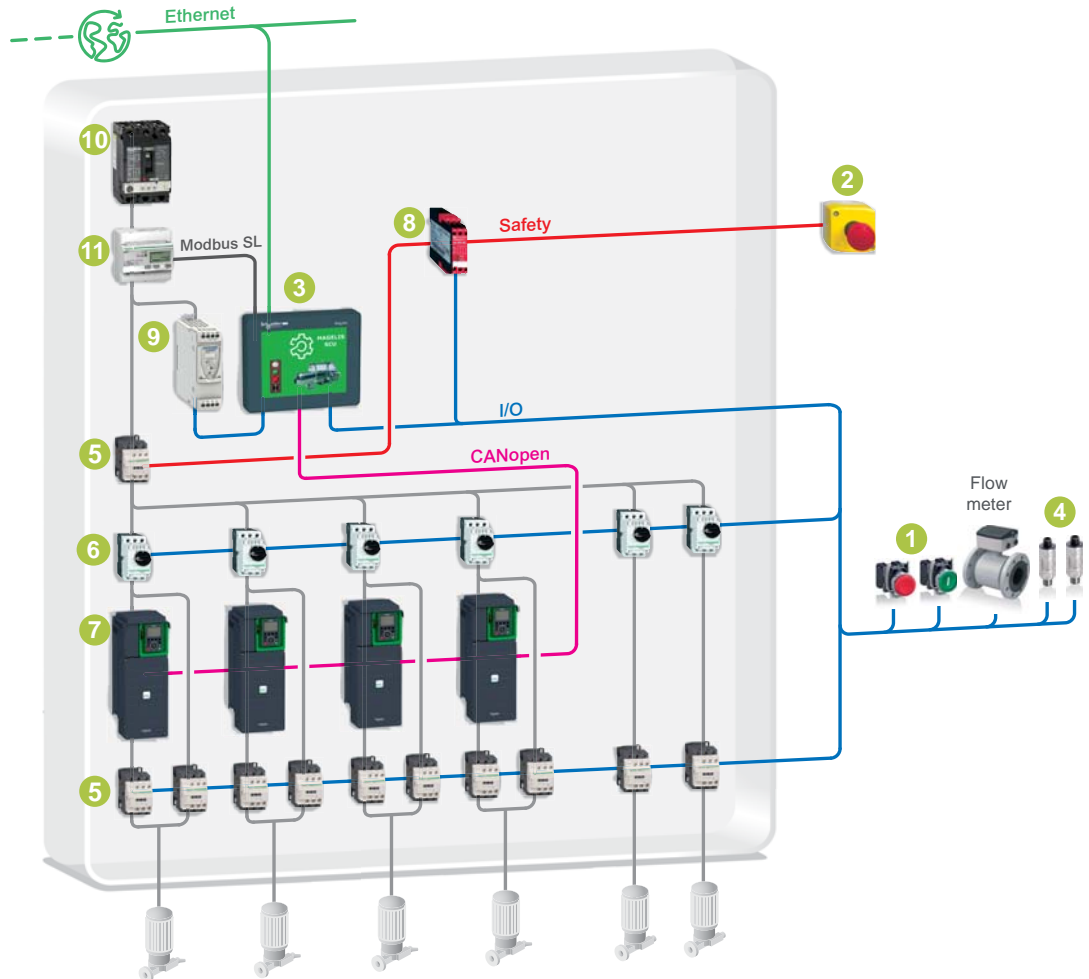

Pumping / Booster / Multi Drive / CANopen / Magelis SCU Controller

## Solution breakdown

> Pushbuttons, Switches, Pilot Lights & Joysticks	1 Harmony XB5 Ø 22 mm plastic pushbuttons, switches, pilot lights Harmony XB4 Ø 22 mm metal pushbuttons, switches, pilot light
> Boxes, Cabling & Interfaces	2 Harmony XALK Emergency stop push button
> HMI (Terminals and Industrial PC)	3 Magelis SCU Controller
> Sensors & RFID System	4 OsiSense XMLP Pressure sensor
> Motor Starters	5 TeSys GV2M Magnetic motor circuit breaker
	6 TeSys GV2P Magnetic motor circuit breaker (rotary knob)
> Drives & Soft Starters	7 Altivar Process ATV600 Variable speed drive
> PAC, PLC & other Controllers	8 Preventa XPS Safety module
> Power Supplies & Transformers	9 Phaseo Switch mode power supply
> Power Circuit breakers & Switches	10 Compact NSX Circuit breaker
> Power & Energy Monitoring System	11 Acti 9 iEM3000 series energy meter

# Pumping

## Solution architectures – Recommended products

### Booster applications

### Single drive booster for Buildings with BMS (BACnet or LonWorks connection)

#### Single drive booster for buildings with BMS (BACnet or LonWorks connection)



#### Cost effective, simpler solution for smaller booster

##### Challenges

##### Your business issues are unique

You need to develop a cost efficient booster for buildings.

You are determined to offer an easy-to-use system with diagnostics.

##### Solution description

Dedicated to simple and standard booster in building. This is the first step towards automation from traditional relay architectures. With a built-in display on Modicon M172 performance Logic controller, this architecture provides very cost efficient solution. Single drive can be used in single or multi drive mode.

##### Value proposition

- > Do not start from the scratch, use TVDAs, to start the application
- > Do not program: use pre-developed and easily configurable functions and templates to develop your application
- > A complete and cost optimized solution
- > Embedded pumping functions like cavitation protection, pump stage and de-stage, PID, and others
- > Increase flexibility with Modicon M172 performance Logic controller
- > Reduced panel size
- > Switching on and off multiple pumps with a single drive to optimize the energy consumption
- > Built-in display or HMI Small panel provides monitoring capabilities which suits your application
- > Connect everywhere: built-in BACnet or LonWorks connectivity provides seamless connectivity to the BMS. The embedded web server provides the possibility for remote access through web visualization by smart phones and internet

##### Differentiation

- > Capable of managing multiple pumps using one drive
- > Maintains the pressure constant in the system with PID, pump stage and de-stage
- > Diagnostic features for easy maintenance
- > Embedded booster and pumps protection using features like cavitation protection
- > Operates smaller pumps (auxiliary pumps) to maintain lower flow requirement
- > Compact size of the controller and drives reduces the panel size

# Pumping

## Solution architectures – Recommended products

Booster applications

Single drive booster for Buildings with BMS (BACnet or LonWorks connection)

Single drive booster for buildings with BMS (BACnet or LonWorks connection)

### Architecture

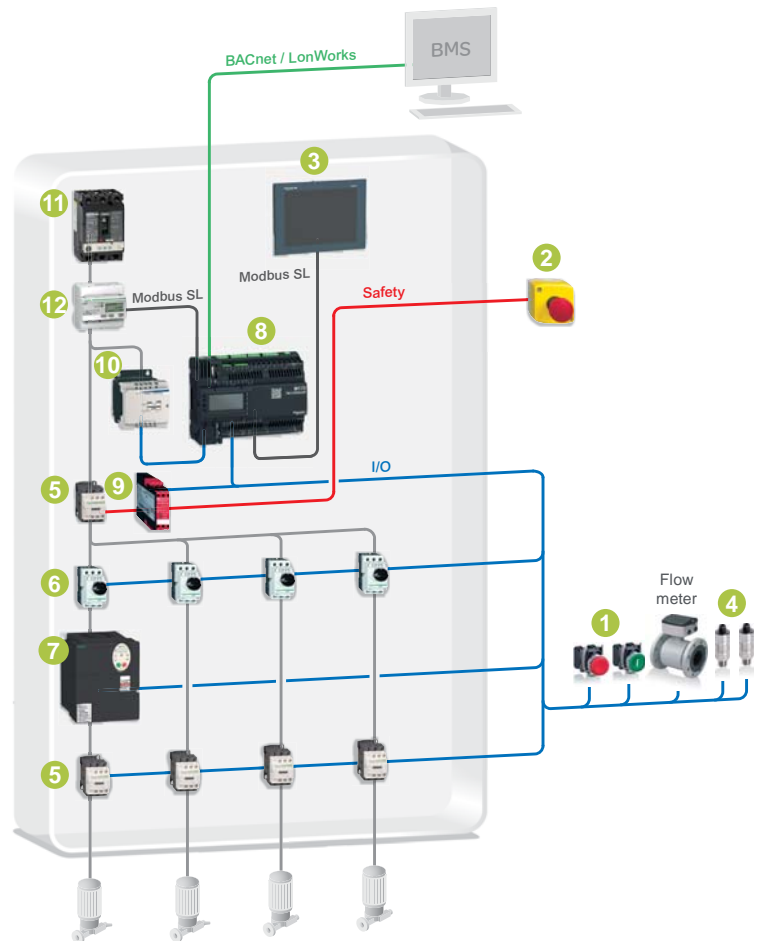

**Pumping / Booster Single Drive / Hardwired / Modicon M172 performance Logic controller**

#### Solution breakdown

> Pushbuttons, Switches, Pilot Lights & Joysticks	1 Harmony XB5 Ø 22 mm plastic pushbuttons, switches, pilot lights Harmony XB4 Ø 22 mm metal pushbuttons, switches, pilot light
> Boxes, Cabling & Interfaces	2 Harmony XALK Emergency stop push button
> HMI (Terminals and Industrial PC)	3 Magelis HMISTU Small panel
> Sensors & RFID System	4 OsiSense XMLP Pressure sensor
> Motor Starters	5 TeSys D Contactor and reversing contactor 6 TeSys GV2P Magnetic motor circuit breaker (rotary knob)
> Drives & Soft Starters	7 Altivar 212 Variable speed drive
> PAC, PLC & other Controllers	8 Modicon M172 performance Logic controller 9 Preventa XPS Safety module
> Power Supplies & Transformers	10 Phaseo Switch mode power supply
> Power Circuit breakers & Switches	11 Compact NSX Circuit breaker
> Power & Energy Monitoring System	12 Acti 9 iEM3000 series energy meter

# Pumping

## Solution architectures – Recommended products

### Booster applications

### Multi drive booster for Buildings with BMS (BACnet or LonWorks connection)

#### Multi drive booster for buildings with BMS (BACnet or LonWorks connection)



#### more energy efficient system providing a higher level of protection for the entire pump and pipe system

##### Challenges

##### Your business issues are unique

You need to develop a booster for buildings with higher level of functionalities, diagnostics, and protection with flexible and scalable I/Os. For you, energy efficient system is very important as your customer is focusing on Energy optimization.

##### Solution description

A powerful solution for Boosters with multiple pumps requiring maximum flexibility and scalability plus higher level of functionality. Connectivity to BMS over BACnet or LonWorks is one of the key features. A combination of power meters, drives, and energy efficiency related functions makes the system efficient.

##### Value proposition

- > Do not start from the scratch, use TVDAs, to start the application
- > Do not program: use pre-developed and easily configurable functions and templates to develop your application
- > A complete and cost optimized solution
- > Embedded pumping functions like cavitation protection, pump stage and de-stage, PID, and others
- > Increase scalability with Modicon M172 performance Logic controller using wide range of I/Os
- > Improve cost-efficiency with built-in display
- > Built-in display provides monitoring capabilities which suits your application
- > Connect everywhere: built-in BACnet or LonWorks connectivity provides seamless connectivity to the BMS. The embedded web server provides the possibility for remote access through web visualization by smart phones and internet

##### Differentiation

- > Multiple pump management using drive for each pump
- > Designed-in energy efficiency while maintaining performance
- > Maintains pressure constant in the system with PID, pump stage and de-stage related functions
- > Advanced diagnostics for each pump for easy maintenance
- > Embedded booster and pumps protection using features like cavitation protection
- > Operates smaller pumps (auxiliary pumps) to maintain lower flow requirement

# Pumping

## Solution architectures – Recommended products

Booster applications

Multi drive booster for Buildings with BMS (BACnet or LonWorks connection)

Multi drive booster for buildings with BMS (BACnet or LonWorks connection)

### Architecture

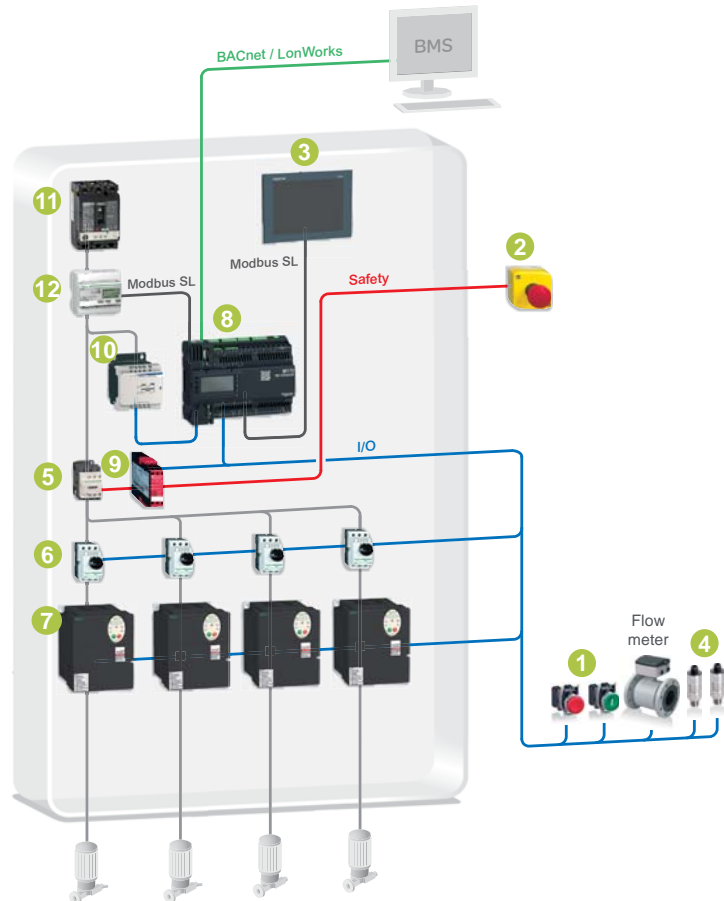

Pumping / Booster Multi Drive / **Hardwired** / Modicon M172 performance Logic controller

#### Solution breakdown

> Pushbuttons, Switches, Pilot Lights & Joysticks	<b>1</b> Harmony XB5 Ø 22 mm plastic pushbuttons, switches, pilot lights <b>2</b> Harmony XB4 Ø 22 mm metal pushbuttons, switches, pilot light
> Boxes, Cabling & Interfaces	<b>3</b> Harmony XALK Emergency stop push button
> HMI (Terminals and Industrial PC)	<b>4</b> Magelis HMISTU Small panel
> Sensors & RFID System	<b>5</b> OsiSense XMLP Pressure sensor
> Motor Starters	<b>6</b> TeSys D Contactor and reversing contactor
> Drives & Soft Starters	<b>7</b> TeSys GV2P Magnetic motor circuit breaker (rotary knob)
> PAC, PLC & other Controllers	<b>8</b> Altivar 212 Variable speed drive
> Power Supplies & Transformers	<b>9</b> Modicon M172 performance Logic controller
> Power Circuit breakers & Switches	<b>10</b> Preventa XPS Safety module
> Power & Energy Monitoring System	<b>11</b> Phaseo Switch mode power supply
	<b>12</b> Compact NSX Circuit breaker
	<b>13</b> Acti 9 iEM3000 series energy meter

# Pumping

## Solution architectures – Recommended products

### Other pumping applications

based on Altivar Process ATV600 Variable speed drive

**Pumping systems, based on Altivar Process ATV600 Variable speed drives, with embedded functions**



Altivar Process drives



**Water & wastewater**



**Mining, minerals & metals**



**Oil & gas**



**Food & Beverage**

#### Presentation

Altivar Process drives offer extensive flexibility in Water & wastewater, Mining, minerals & metals, Oil & gas and Food & beverage applications. Depending on the customer's requirements, wall-mounting drives, built-in cabinet and floor-standing solutions are available with IP 21, IP 23, IP 54 and IP 55 protection degrees.

#### Solution description

ATV600 is a range of

- > Wall-mounting drives from 0.75 kW to 160 kW / 1 to 215 HP
- > Floor-standing drives from 110 kW to 315 kW / 150 to 420 HP
- > Drive Systems from 110 kW to 800 kW / 150 to 1000 HP

#### Application

##### Water & wastewater applications:

- > Pumping, suction, dosing, odour control, ventilation, aeration and sludge removal

##### Oil & gas applications:

- > Pumps (submersible, hydraulic, pipeline, reverse flow, water injection, kerosene)

##### Mining, minerals & metals applications:

- > Pumps

##### Food & Beverage applications:

- > Pumps, Drying fan

#### Benefits

- > Services Oriented Drives
  - > This concept of drives meets the major needs of process and utilities in terms of equipment efficiency and Total Cost of ownership by supporting the energy management, asset management and also the overall performance of the process.
  - > Sustainable cost savings thanks to predictive condition-based maintenance
  - > Up to 20% downtime reduction without additional investment
- > Fluids Management Processing
  - > Embedded Pump curves embedded (easy to set 5 points curve)
  - > Anti-jam function prevents downtime
  - > Limits leakage by reducing pressure when demand is low
- > Energy Saving
  - > Optimizes energy consumption
  - > Accurate power measurement provides information for energy management
  - > Reduced energy consumption in standby mode
- > Real Time Intelligence: Web server and services via Ethernet
  - > Embedded web server interface based on the Ethernet network gives you process monitoring with your daily working tools
  - > Local and remote access to energy use and customized dashboards means your energy usage is visible anywhere, any time, on PC, tablet or smartphone.
- > Custom Engineered Drives
  - > Schneider Electric's expertise in design and application services delivers solution-specific designs dedicated to your process requirements for seamless plant integration and minimize design and delivery risks
  - > Reduces the commissioning and adaptation time
- > Enhanced Drives Specifications
  - > Compact and modular, suitable even in harsh environments, Altivar Process is perfect for upgrades, retrofits, or new installations.
  - > Withstand the harsh conditions of use, both from an electrical and environmental perspective

# Pumping

Solution architectures – Recommended products

Other pumping applications

based on Altivar Process ATV600 Variable speed drives

Pumping systems, based on Altivar Process ATV600 Variable speed drives, with embedded functions

## Architectures

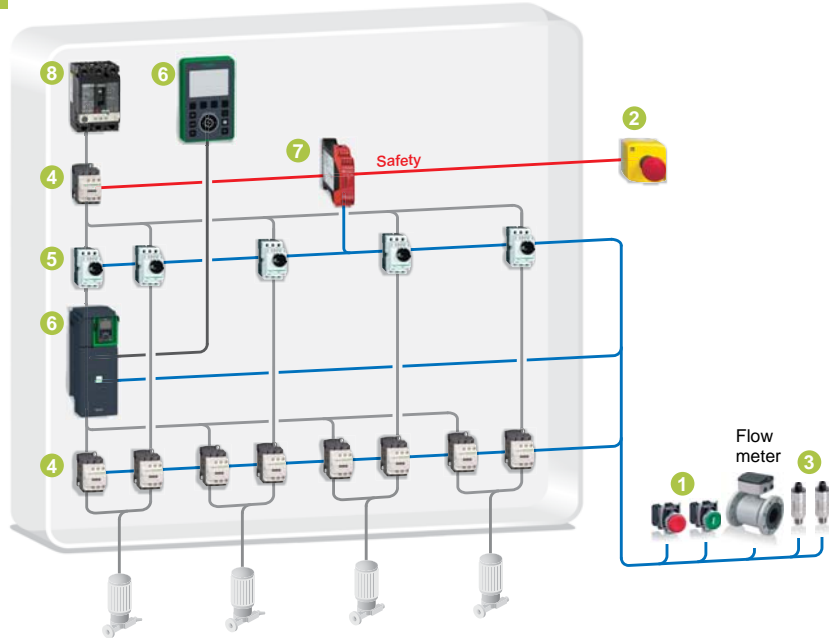

Pumping / Single drive / **Hardwired** / Altivar Process ATV600 V.S.D.

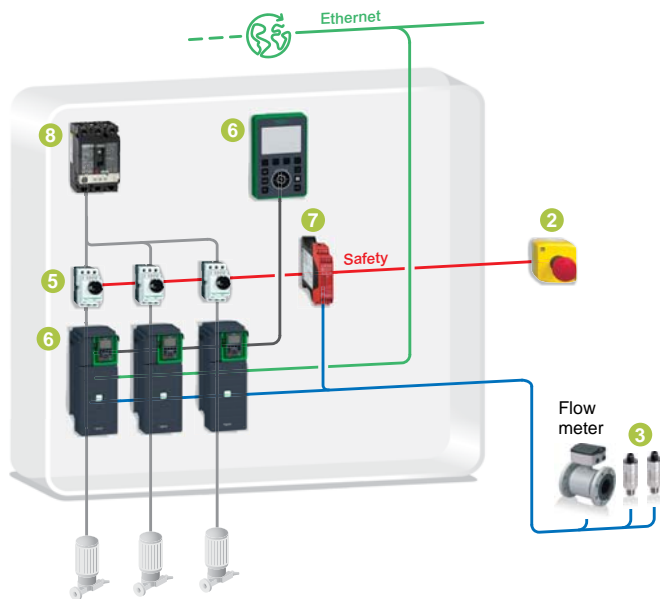

Pumping / Multi drive / **Ethernet** / Altivar Process ATV600 V.S.D.

Solution breakdown

> Pushbuttons, Switches, Pilot Lights & Joysticks	1	Harmony XB5 Ø 22 mm plastic pushbuttons, switches, pilot lights Harmony XB4 Ø 22 mm metal pushbuttons, switches, pilot light
> Boxes, Cabling & Interfaces	2	Harmony XALK Emergency stop push button
> Sensors & RFID System	3	OsiSense XMLP Pressure sensor
> Motor Starters	4	TeSys D Contactor and reversing contactor
> Drives & Soft Starters	5	TeSys GV2P Magnetic motor circuit breaker (rotary knob)
> PAC, PLC & other Controllers	6	Altivar Process ATV600 Variable speed drive and remote display
> Power Circuit breakers & Switches	7	Preventa XPS Safety module
	8	Compact NSX Circuit breaker

# Pumping

Solution architectures – Recommended products

Service & support

Service and support behind you every step of the way

## Stage in the product life cycle: **Design**

What we can bring you at this stage...



### Design

#### We find the optimum solution for your needs

- > Based on your needs, our Solution Application Experts and Application Design Experts (SAE/ADE) work out innovative technical solutions including:
  - > Co-engineering
  - > Tests
  - > Validation

#### We understand your challenges

- > Consulting
- > Audits

#### We execute the solution with a comprehensive service agreement

- > Our solution design and delivery centers (Flex Centers) are committed to quality and results and provide tests, validation, and commissioning

#### We improve your team's competencies

- > In-class and on-site training



### Build

## Stage in the product life cycle: **Build**

What we can bring you at this stage...

#### We take care of the delivery of your solution

- > Availability of components through a large worldwide network of distributors
- > Collaboration, management, and delivery through local partners
- > With Schneider Electric as your turnkey solution partner, your solutions will include:
  - > Project management and responsibility
  - > Engineered systems
  - > Third-party components management
  - > Customizations and adaptations

#### We provide on-site services and support

- > Secondment of qualified personnel to deliver on-site engineering and technical services

#### We improve your service team's competencies

- > Service and commissioning training
- > Supply chain optimization

# Pumping

Solution architectures – Recommended products

Service & support

Service and support behind you every step of the way

Stage in the product life cycle: **Operate**

What we can bring you at this stage...



**We provide international sales and after-sales services for you and your customers**

- > Maintenance contracts
- > Spare parts and repairs
- > Just-in-time delivery
- > Return of goods
- > Service expertise
- > Diagnosis and repair
- > Environmental measurements (EMC, fieldbus, thermography, power quality analyses, etc.)
- > Customer International Support (CIS) as a single point of contact
- > A network of dedicated local country experts
- > Web-based collaborative platform for efficient communication

**We improve your customers' competencies**

- > In-class customer training and on-site training
- > Customer service and commissioning training



Operate



Stage in the product life cycle: **Improve**

What we can bring you at this stage...

**We improve your pumping machine ranges**

- > Consulting

**We improve your customers' pumping machines in their production line**

- > Audits
- > Training
- > Migration and upgrade
- > Services expertise:
  - > Consultancy
  - > Retrofitting



Improve

**Schneider Electric Industries SAS**

**Head Office**  
35, rue Joseph Monier  
F-92500 Rueil-Malmaison  
France

[www.schneider-electric.com/pumping](http://www.schneider-electric.com/pumping)

The information provided in this documentation contains general descriptions and/or technical characteristics of the performance of the products contained herein. This documentation is not intended as a substitute for and is not to be used for determining suitability or reliability of these products for specific user applications. It is the duty of any such user or integrator to perform the appropriate and complete risk analysis, evaluation and testing of the products with respect to the relevant specific application or use thereof. Neither Schneider Electric nor any of its affiliates or subsidiaries shall be responsible or liable for misuse of the information contained herein.

Design: Schneider Electric  
Photos: Schneider Electric

DIA3ED2151003EN