

Altivar 32

Variable speed drives
for synchronous and asynchronous motors

PROFIBUS DP Communication Manual

03/2010



Schneider
Electric

The information provided in this documentation contains general descriptions and/or technical characteristics of the performance of the products contained herein. This documentation is not intended as a substitute for and is not to be used for determining suitability or reliability of these products for specific user applications. It is the duty of any such user or integrator to perform the appropriate and complete risk analysis, evaluation and testing of the products with respect to the relevant specific application or use thereof. Neither Schneider Electric nor any of its affiliates or subsidiaries shall be responsible or liable for misuse of the information contained herein. If you have any suggestions for improvements or amendments or have found errors in this publication, please notify us.

No part of this document may be reproduced in any form or by any means, electronic or mechanical, including photocopying, without express written permission of Schneider Electric. All pertinent state, regional, and local safety regulations must be observed when installing and using this product. For reasons of safety and to help ensure compliance with documented system data, only the manufacturer should perform repairs to components.

When devices are used for applications with technical safety requirements, the relevant instructions must be followed.

Failure to use Schneider Electric software or approved software with our hardware products may result in injury, harm, or improper operating results.

Failure to observe this information can result in injury or equipment damage.

© 2010 Schneider Electric. All rights reserved.

Table of Contents

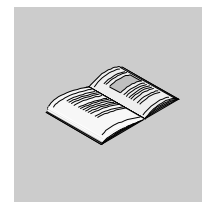

	Safety Information	4
	About the Book	5
Chapter 1	VW3 A3 607 PROFIBUS DP V1 Communication Card Overview	7
	General Presentation	8
	Telegram	9
	Notation	11
Chapter 2	Installation and Configuration	12
	Firmware and GSD Version Compatibility	13
	Wiring	14
	Installation	15
	Electrical Installation	17
Chapter 3	Setup	18
	Introduction	19
	PROFIBUS DP Settings Menu of the ATV32	19
	Configuration of the Option Card	19
	Additional Monitoring Parameters	20
Chapter 4	Configuration	21
	Configuring the Control Channel	22
	Configuring Monitor Parameters	25
	Configuring Communication Interruption Management	26
Chapter 5	Telegram 100, 101 and 102	27
	Overview	28
	Configuring an ATV32 With a Siemens© S7-315	30
	Configuration of the Altivar 32 With the Telegram 100	31
	Configuring an ATV32 With the Telegram 101 or 102	33
	Parameters Management With 100, 101 and 102	34
Chapter 6	Telegram 1	38
	Overview	39
	State Diagram	40
	Command Word and Status Word	41
	Speed Setpoint	44
	DP V1 - PROFIdrive / Acyclic Messaging	44
Chapter 7	Common Additional Features	45
	Identification and Maintenance Data	46
	I&M Records Description	47
Chapter 8	Diagnostic and Monitoring	48
	PROFIBUS Interface Settings	49
	Diagnostic	50
	Monitoring of Communication Channels	52
Chapter 9	Annexes	54
	Annex A - Simple CONT Language FC (Controlling the Drive in CiA402 Mode)	55
	Annex B - The PROFIdrive Parameters Channel	60

Safety Information

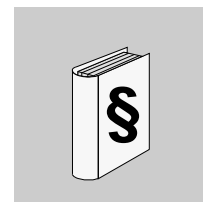

Important Information

NOTICE

Read these instructions carefully, and look at the equipment to become familiar with the device before trying to install, operate, or maintain it. The following special messages may appear throughout this documentation or on the equipment to warn of potential hazards or to call attention to information that clarifies or simplifies a procedure.



The addition of this symbol to a Danger or Warning safety label indicates that an electrical hazard exists, which will result in personal injury if the instructions are not followed.



The addition of this symbol to a Danger or Warning safety label indicates that an electrical hazard exists, which will result in personal injury if the instructions are not followed.

▲ DANGER

DANGER indicates an imminently hazardous situation, which, if not avoided, **will result** in death or serious injury.

▲ WARNING

WARNING indicates a potentially hazardous situation, which, if not avoided, **can result** in death, serious injury or equipment damage.

▲ CAUTION

CAUTION indicates a potentially hazardous situation, which, if not avoided, **can result** in injury or equipment damage.

CAUTION

CAUTION, used without the safety alert symbol, indicates a potentially hazardous situation which, if not avoided, **can result** in equipment damage.

PLEASE NOTE

The word “drive” as used in this manual refers to the controller portion of the adjustable speed drive as defined by NEC.

Electrical equipment should be installed, operated, serviced, and maintained only by qualified personnel. No responsibility is assumed by Schneider Electric for any consequences arising out of the use of this material.

About the Book

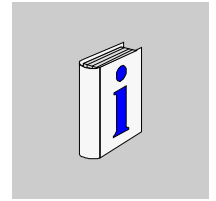

At a Glance

Document Scope

The purpose of this document is to:

- show you how to install the PROFIBUS fieldbus on your Altivar 32,
- show you how to configure the Altivar 32 to use PROFIBUS for monitoring and control,
- provide examples of setup using Telegrams.

NOTE: Read and understand this document and all related documents (see below) before installing, operating, or maintaining your ATV32.

Validity Note

This documentation is valid for the Altivar 32 DeviceNet fieldbus.

Related Documents

Title of Documentation	Reference Number
ATV32 Quick Start	S1A41715
ATV32 Installation manual	S1A28686
ATV32 Programming manual	S1A28692
ATV32 Modbus manual	S1A28698
ATV32 CANopen® manual	S1A28699
ATV32 Communication parameters	S1A44568
ATV32 Atex manual	S1A45605
ATV32 Safety manual	S1A45606
ATV32 other option manuals: see www.schneider-electric.com	

You can download the latest versions of these technical publications and other technical information from our website at www.schneider-electric.com.

Product Related Information

⚠ DANGER

UNINTENDED EQUIPMENT OPERATION

- Read and understand this manual before installing or operating the Altivar 32 drive.
- Any changes made to the parameter settings must be performed by qualified personnel.

Failure to follow these instructions will result in death or serious injury.

⚠ ⚠ DANGER

HAZARD OF ELECTRIC SHOCK, EXPLOSION OR ARC FLASH

- Read and understand this manual before installing or operating the Altivar 32 drive. Installation, adjustment, repair, and maintenance must be performed by qualified personnel.
- The user is responsible for compliance with all international and national electrical code requirements with respect to grounding of all equipment.
- Many parts of this drive, including the printed circuit boards, operate at the line voltage. **DO NOT TOUCH.** Use only electrically insulated tools.
- **DO NOT** touch unshielded components or terminal strip screw connections with voltage present.
- **DO NOT** short across terminals PA/+ and PC/- or across the DC bus capacitors.
- Before servicing the drive:
 - Disconnect all power, including external control power that may be present.
 - Place a “DO NOT TURN ON” label on all power disconnects.
 - Lock all power disconnects in the open position.
 - **WAIT 15 MINUTES** to allow the DC bus capacitors to discharge.
 - Measure the voltage of the DC bus between the PA/+ and PC/- terminals to ensure that the voltage is less than 42 Vdc.
 - If the DC bus capacitors do not discharge completely, contact your local Schneider Electric representative. Do not repair or operate the drive
- Install and close all covers before applying power or starting and stopping the drive.

Failure to follow these instructions will result in death or serious injury.

⚠ WARNING

DAMAGE DRIVE EQUIPMENT

Do not operate or install any drive or drive accessory that appears damaged.

Failure to follow these instructions can result in death, serious injury, or equipment damage.

⚠ WARNING

LOSS OF CONTROL

- The designer of any control scheme must
 - consider the potential failure modes of control paths and,
 - for certain critical control functions, provide a means to achieve a safe state during and after a path failure.

Examples of critical control functions are emergency stop and overtravel stop.

- Separate or redundant control paths must be provided for critical control functions.
- System control paths may include communication links. Consideration must be given to the implications of unanticipated transmission delays or failures of the link.⁽¹⁾

Failure to follow these instructions can result in death, serious injury, or equipment damage.

(1) For additional information, refer to NEMA ICS 1.1 (latest edition), “Safety Guidelines for the Application, Installation, and Maintenance of Solid State Control” and to NEMA ICS 7.1 (latest edition), “Safety Standards for Construction and Guide for Selection, Installation and Operation of Adjustable-Speed Drive Systems.”

VW3 A3 607 PROFIBUS DP V1 Communication Card Overview



What's in this Chapter?

This chapter contains the following topics:

Topic	Page
General Presentation	8
Telegram	9
Notation	11

General Presentation



Compatibility

The VW3 A3 607 communication card enables the integration of an Altivar 32 variable speed drive into a PROFIBUS DP network. This card offers the possibility to control its host drive in native profile or with the PROFIdrive profile.

The compatibility with PROFIBUS DPV1 adds additional control features such as acyclic messaging and the control from a second Master (also called MS1).

Profile	Telegrams
Native drive profile (CiA@402)	100,101,102
I/O profile	100,101,102
PROFIdrive	1

There are four modes of operation which are telegram 1, 100, 101 and 102. The telegram 1 is based on the PROFIdrive V4.1 Application profile part of the IEC 61800-7. The three other telegrams are based on the native profile of the drive.

NOTE: This mode is based on PROFIdrive but it doesn't support it to 100%.

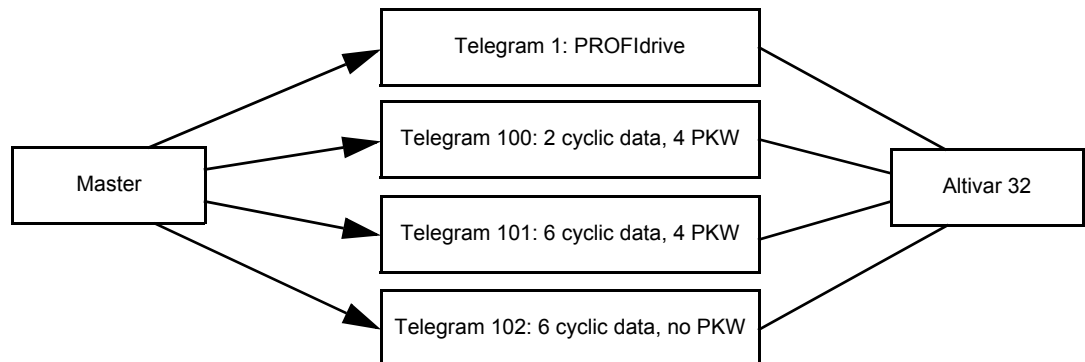

Data is exchanged in order to make use of all the Altivar 32 functions.

The following features are supported by the VW3 A3 607 communication card:

- 4 configurable telegrams (Optimizes the I/Os usage of the master)
- Mapping of the process data from the master
- Parameters management compliant with PROFIdrive V4.1
- Baud rate from 9.6 to 12000 kbps (Automatic detection of the bus speed)
- Supports standard Identification & maintenance requests
- Supports diagnostic data with VSD status (Variable Speed Drive Status)
- Several DP V1 messaging modes
- Host drive can be handled from two masters (MS0 and MS1)
- Quick setup from drive side

The card has a 9-pin female SUB-D connector for connection to the PROFIBUS DP bus.

The connector and cable for connection to the PROFIBUS DP bus must be ordered separately.

Telegram

Overview

There are 4 different telegrams:

PROFIdrive	Specific Mode
Telegram 1	Telegram 100, 101, 102

In the sections below, each telegram is described with a synoptic diagram that explains how the different services are managed according to the relationship with the Master, the option or the Host Altivar drive.

Telegrams 100, 101, 102: Specific Mode

The following diagram shows the management of telegrams 100, 101 and 102 in specific mode:

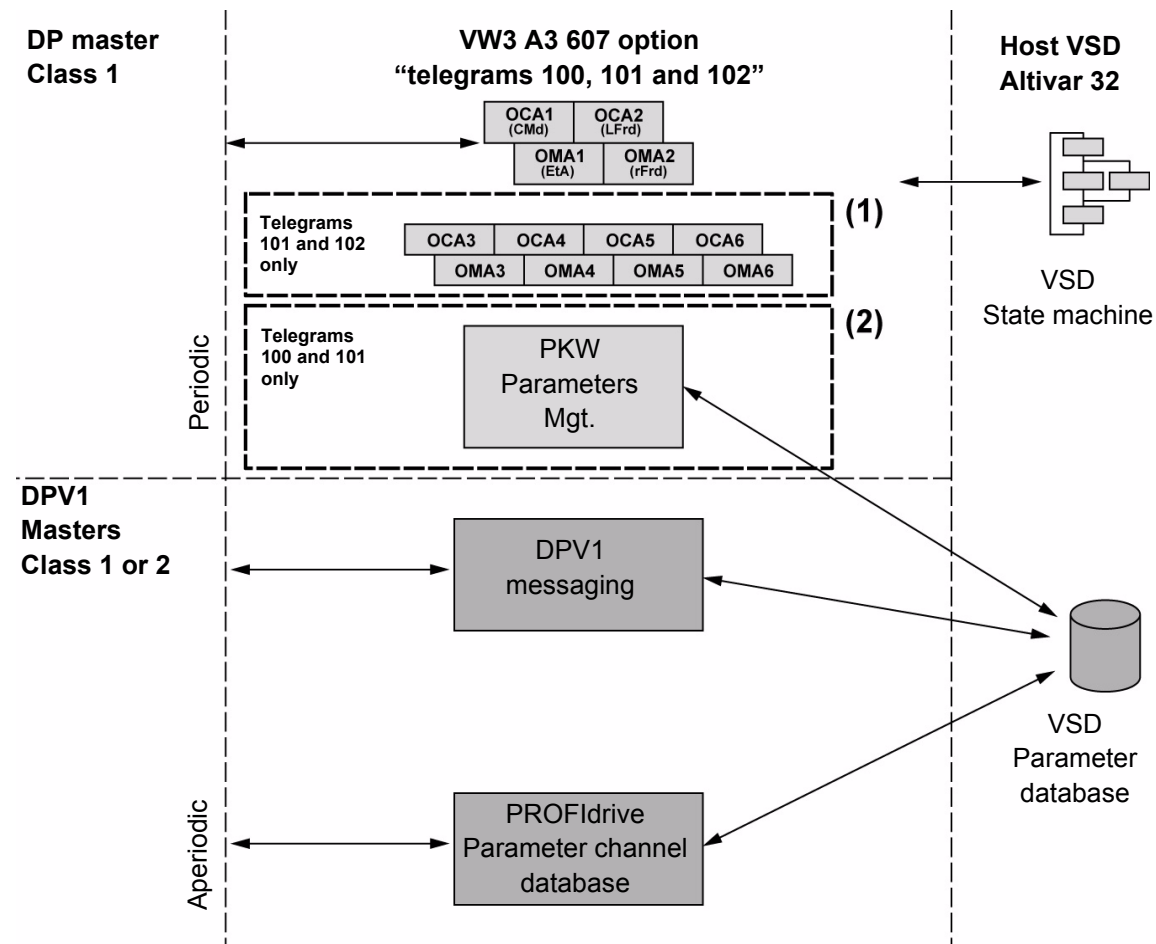

(1) 4 additional parameters can be configured in the communication scanner.

(2) PKW mechanism compliant with Altivar 71 and Altivar 312.

The Altivar 32 is controlled with the process data by a DPV0 or a DPV1 master. The command and status process data are compliant with:

- the Altivar 32 native profile (IEC 61800-7 / CiA402)
- I/O profile

NOTE: If the selected telegram is PROFIdrive (and CHCF is I/O), the drive displays EPF2.

The choice between these 2 modes is a drive configuration matter. Refer to the programming manual for more details, however some examples are given in this document.

Aperiodic data are managed by masters (class1 or 2) for monitoring and configuring the Altivar 32. Messaging services (based on DPV1) and the PROFIdrive parameters channel management are also supported.

Telegram 1: PROFIdrive

PROFIdrive is one of the standardized drive profile part of the IEC 61800-7 standard. It was first issued by the German organization PNO (PROFIBUS Nutzerorganisation) who manages the PROFIBUS standard.

The following diagram shows the management of Telegram 1:

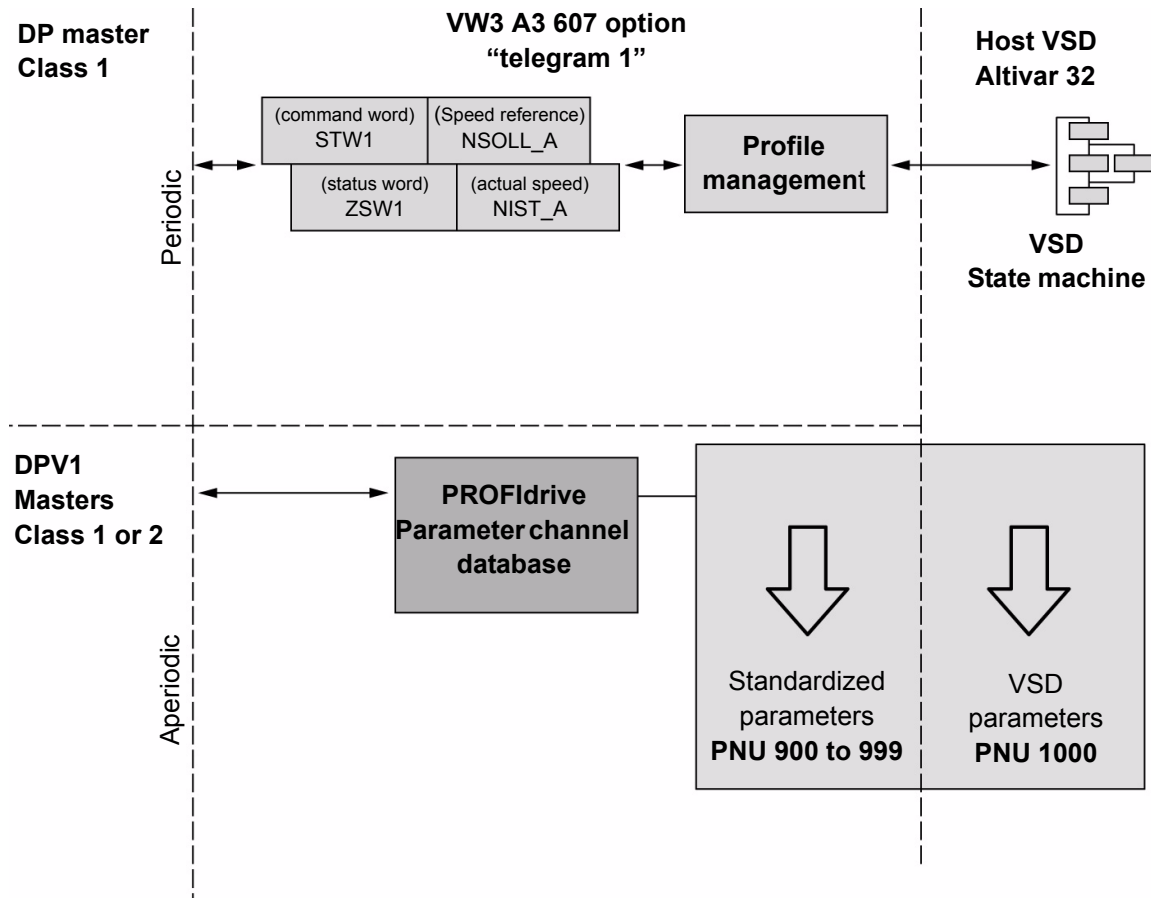

The Altivar 32 is controlled with the process data (PPO3) by a DPV0 or DPV1 master. The command and status process data are compliant with IEC 61800-7/PROFIdrive.

Aperiodic data are managed by masters (class1 or 2) for monitoring and configuring the Altivar 32. These features are based on PROFIBUS DPV1 and are compliant with the PROFIdrive parameter channel services.

NOTE: This mode is based on PROFIdrive but it doesn't support it to 100%.

Notation

Drive Terminal Displays

The graphic display terminal (to be ordered separately - reference VW3 A1 101) menus are shown in square brackets.

Example: **[COMMUNICATION]**

The integrated 7-segment display terminal menus are shown in round brackets.

Example: **(L D P -)**

Parameter names are displayed on the graphic display terminal in square brackets.

Example: **[Fallback speed]**

Parameter codes are displayed on the integrated 7-segment display terminal in round brackets.

Example: **(L F F)**

Formats

In this manual, hexadecimal values are written as follows: 16#

Installation and Configuration



2

What's in this Chapter?

This chapter contains the following topics:

Topic	Page
Firmware and GSD Version Compatibility	13
Wiring	14
Installation	15
Electrical Installation	17

Firmware and GSD Version Compatibility

Only VW3 A3 607 option cards, with minimum 1.5IE01 firmware version, are compliant with ATV32.

NOTE: Check the firmware version on the packaging label (on the right part of the label).

The associated GSD is the following SCHN0C95.gsd. This file is available on www.schneider-electric.com.

Wiring

Check that the card catalog number marked on the label is the same as that on the delivery note corresponding to the purchase order.

Remove the communication module from its packaging and check that it has not been damaged in transit.

CAUTION

RISK OF DAMAGE TO THE DRIVE

- Install only communication modules designed for the drive. See references in the catalog.
- Do not insert any other thing than communication module inside the drive.

Failure to follow these instructions can result in equipment damage.

⚠ ⚠ DANGER

HAZARD OF ELECTRIC SHOCK, EXPLOSION OR ARC FLASH

Read and understand the precautions in “About the Book” on page 5 before performing the procedure in this section.

Failure to follow these instructions will result in death or serious injury.

The VW3 A3 607 option card is equipped with a 9-pin Sub D connector for the connection to PROFIBUS DP network.

Use only approved PROFIBUS connectors. The PROFIBUS connectors are suitable for connecting the bus signal.

- Connect the PROFIBUS signals.
- If the device is at the end of the network, use a PROFIBUS connector with a terminating resistor.
- Fasten the cables to the cable guide. The cable guide is not a strain relief.

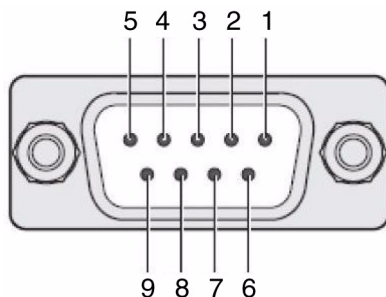

The following table describes the pin out of the SubD9 connector:



Pin	Signal Name	Description
1	Shield	Shield protective ground
2	-	Not connected
3	RxD/TxD-P	Receive/Transmit-data-P
4	CNTR-P	Control-P
5	DGND	Data ground
6	VP	Voltage Plus
7	-	Not connected
8	RxD/TxD-N	Receive/Transmit-Data-N
9	-	Not connected

Installation

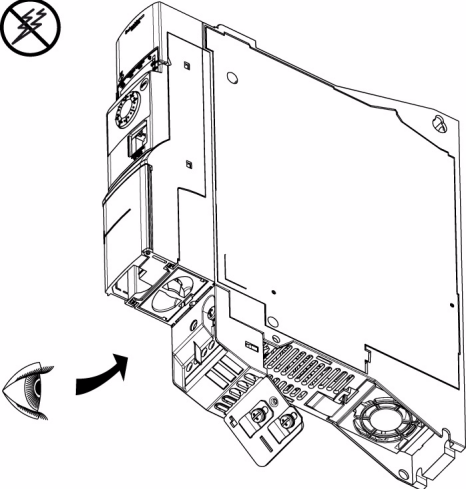
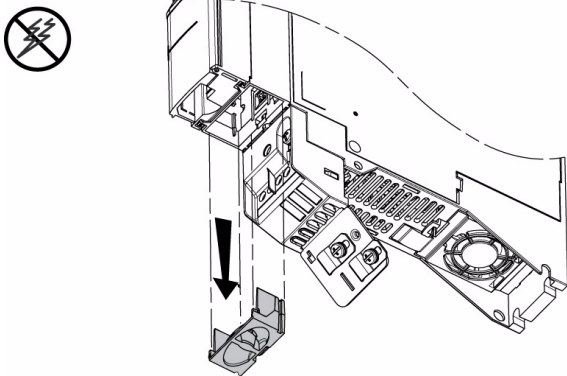
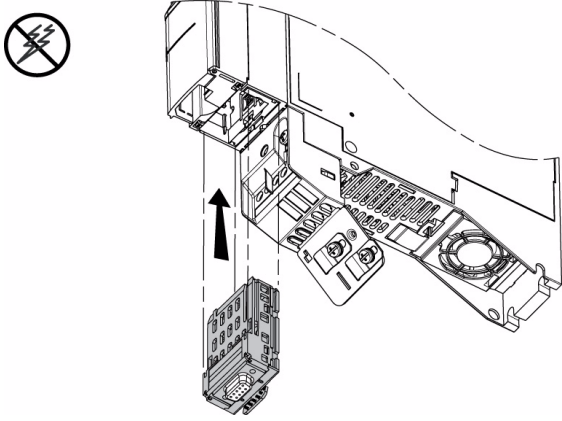
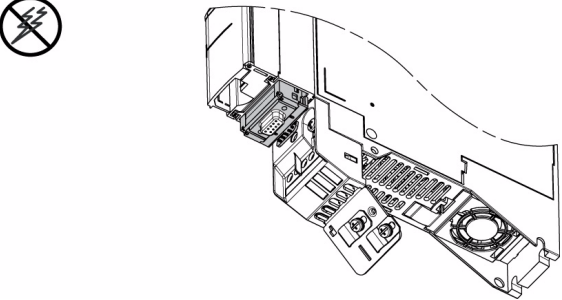
Install the communication module in ATV32 as follows:

Step	Action	Comment
1	Ensure that the power is off. Locate the option card port on the bottom of the ATV32.	
2	Extract the cover.	
3	Insert the communication module.	
4	Check that the module is correctly inserted and locked mechanically in the drive.	

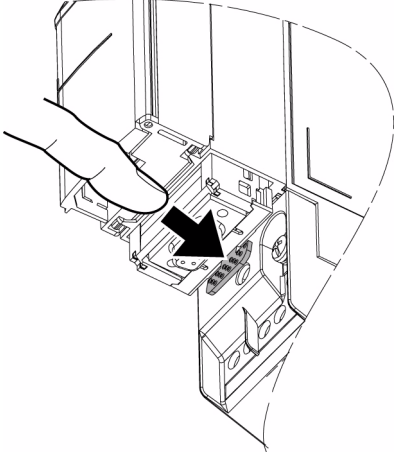
Extract the communication module as follows:

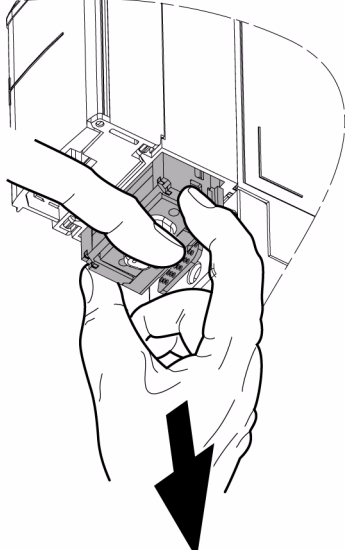
Step	Action	Comment
1	Ensure that the power is off. Press the strip.	 
2	Extract the module while maintaining the strip pressed.	 

Electrical Installation

Shield	Required, both ends grounded
Twisted Pair	Required
PELV	Required
Cable composition	6 x 0.34 mm ² (6 x AWG22, 2 x AWG24)
Max. cable length	See table below
Special features	-

The maximum cable length depends on the baud rate and the signal propagation delay. The higher the baud rate, the shorter the bus cable needs to be.

Data rate (kbps)	9.6	19.2	93.75	187.5	500	1500	3000	6000	12000
Distance m (ft.)	1200 (4000)	1200 (4000)	1200 (4000)	1000 (3300)	400 (1300)	200 (650)	100 (330)	100 (330)	100 (330)

- Use equipotential bonding conductors, see product manual.
- Use pre-assembled cables to reduce the wiring mistakes.
- Verify that wiring, cables and connected interfaces meet the PELV (Protective Extra Low Voltage) requirements.

Setup



3

What's in this Chapter?

This chapter contains the following topics:

Topic	Page
Introduction	19
PROFIBUS DP Settings Menu of the ATV32	19
Configuration of the Option Card	19
Additional Monitoring Parameters	20

Introduction

From the drive side, the setup of the communication option is simplified: the main parameter to set is the slave address of the drive on the PROFIBUS DP network.

All other settings are defined at the PROFIBUS DP master level and are transmitted to the device when the network starts up.

However, additional information is available in the communication menu dedicated to the PROFIBUS DP option. This information is useful during commissioning and maintenance: they indicate the configured settings and the mode(s) currently in operation.

PROFIBUS DP Settings Menu of the ATV32

The PROFIBUS DP menu is reachable from the drive main menu:

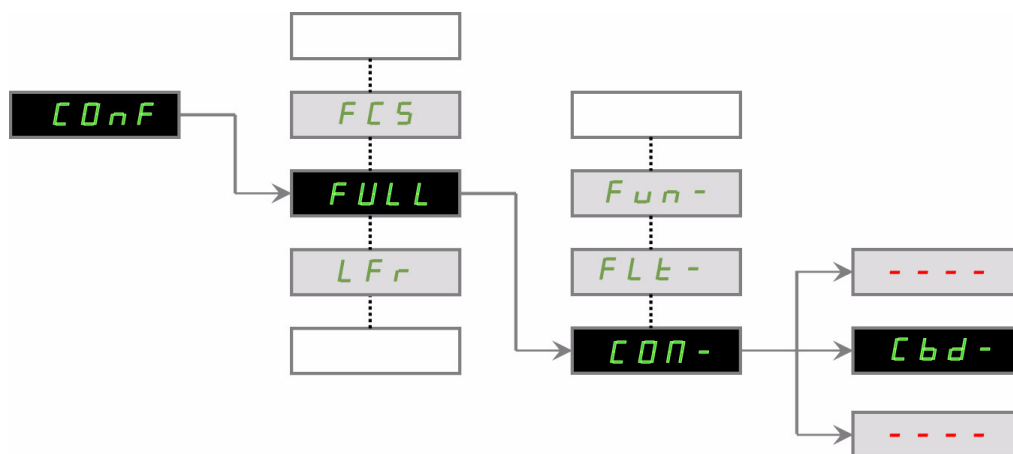

This menu is only visible if a communication card is plugged in the drive.

Configuration of the Option Card

Address Setting

This parameter defines the DP slave address between 2 and 126.

Parameter Description	Possible Values	Terminal Display	Default Value
[Address] (AdrC)	2 to 126	[2] (2)...[126] (126)	[126] (126)

Additional Monitoring Parameters

The following parameters, part of the PROFIBUS option menu, are monitoring parameters and are not writable.

Actual Baudrate and Configured Telegram

Parameter Description	Possible Values	Default Value
[Data rate used] (<i>b d r U</i>)	No Auto 9,6 kbps 19,2 kbps 45.45 kbps 93,75 kbps 187,5 kbps 500 kbps 1,5 Mbps 3 Mbps 6 Mbps 12 Mbps	[Not config.] (<i>n 0</i>)
[PPO profile used] (<i>P r F L</i>)	UNCG 1: PROFdrive 100: Device specific 101: Device specific 102: Device specific	[UNCG] (<i>U N C G</i>)
[DP Master Active] (<i>d P M A</i>)	1: Active Master 1 2: Active Master 2	[1] (<i>1</i>)

Configured Cyclic Exchanges (cyclic data)

The following table lists the monitoring parameters with read only:

Parameter Description	Default Value
Configured address of the first cyclic data [Scan.Out1 address] (<i>D C A 1</i>)	[CMD] (<i>C M D</i>)
Configured address of the 2nd cyclic data [Scan.Out2 address] (<i>D C A 2</i>)	[LFRD] (<i>L F r d</i>)
Configured address of the 3rd cyclic data [Scan.Out3 address] (<i>D C A 3</i>)	[not configured] (<i>0</i>)
Configured address of the 4th cyclic data [Scan.Out4 address] (<i>D C A 4</i>)	[not configured] (<i>0</i>)
Configured address of the 5th cyclic data [Scan.Out5 address] (<i>D C A 5</i>)	[not configured] (<i>0</i>)
Configured address of the 6th cyclic data [Scan.Out6 address] (<i>D C A 6</i>)	[not configured] (<i>0</i>)
Configured address of the first cyclic data [Scan.IN1 address] (<i>D N A 1</i>) (read from the device)	[ETA] (<i>E t A</i>)
Configured address of the 2nd cyclic data [Scan.IN2 address] (<i>D N A 2</i>)	[RFRD] (<i>r F r d</i>)
Configured address of the 3rd cyclic data [Scan.IN3 address] (<i>D N A 3</i>)	[not configured] (<i>0</i>)
Configured address of the 4th cyclic data [Scan.IN4 address] (<i>D N A 4</i>)	[not configured] (<i>0</i>)
Configured address of the 5th cyclic data [Scan.IN5 address] (<i>D N A 5</i>)	[not configured] (<i>0</i>)
Configured address of the 6th cyclic data [Scan.IN6 address] (<i>D N A 6</i>)	[not configured] (<i>0</i>)

NOTE: The communication scanner is configured by the master.

Diagnose

See "Diagnostic" on page 50.

Configuration



4

What's in this Chapter?

This chapter contains the following topics:

Topic	Page
Configuring the Control Channel	22
Configuring Monitor Parameters	25
Configuring Communication Interruption Management	26

Configuring the Control Channel

This chapter explains through 3 examples how to configure the drive for operation from communication network. Of course several other combinations are possible. The whole coverage of these possibilities is not in the scope of this document. For more information please refer to the programming manual.

- I/O Mode - a simple command Word (based on Forward, reverse and reset binary commands).
- Combined Mode (with native profile CiA402) - Both reference and command word come from the communication network.
- Separate (with native profile CiA402) - Reference and command come from separate sources: for example, the command (in CiA402) comes from the communication network and the reference from the HMI.

Configuration of the Drive for Operation in I/O Profile

To illustrate the I/O Profile, we will describe a simple example, which can be of course extended with additional features. The Command word is made of Run forward (bit 0 of **CMD**), run reverse (bit 1 of **CMD**), and a detected fault reset (bit 7 of **CMD**).

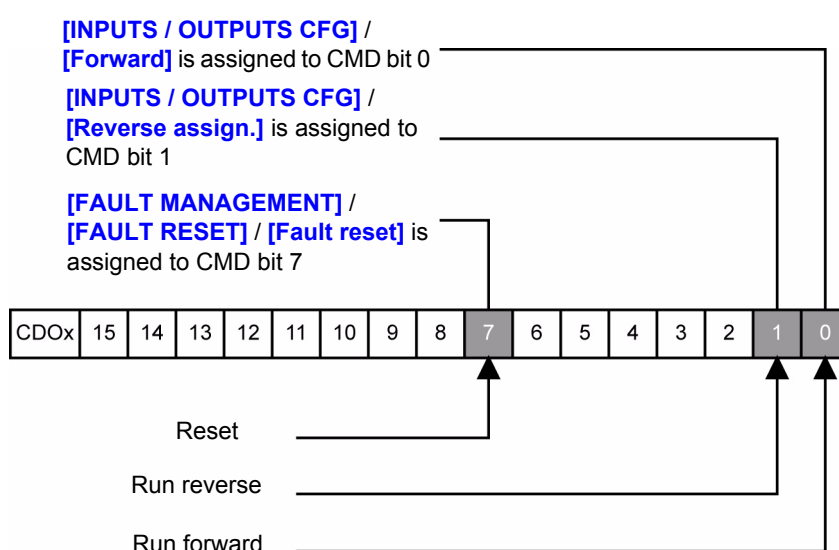

NOTE: This operating mode is not applicable when the drive is configured from the master to operate with the telegram 1 (PROFIdrive). The drive will trip in **(E P F 2)** external detected fault.

The settings will be the following:

[Ref.1 channel] (F r l)	[Separate] (S E P)
[Profile] (C H C F)	[I/O profile] (I O)
[Cmd switching] (C C S)	Default value
[Cmd channel 1] (C d l)	[Com. card] (n E k)

The bits of the command word must now be configured.

In the **[INPUTS / OUTPUTS CFG]** menu, configure:

[Forward] (F r d)	[Cd00] (C d 0 0)
[Reverse assign.] (r r S)	[Cd01] (C d 0 1)

In the **[FAULT MANAGEMENT]** menu, **[FAULT RESET]** submenu, configure:

[Fault reset] (r S F)	[Cd07] (C d 0 7)
---------------------------------------	----------------------------------

Configuration of the Drive for Operation With CiA402 Profile in Combined Mode

This chapter describes how to configure the settings of the drive if it is controlled in CiA402 Mode. The example focuses on the Not separate mode. Additional modes such separate Mode are detailed in the ATV32 Programming manual.

NOTE: This mode is also possible in association with the telegram 1.

In the Command Menu **[Command]** (C E L -):

- **[Ref.1 Channel]** (F r I): is set on according to the communication source you can choose in the following table:

Origin of the control	Ref1 Channel setting
PROFIBUS	[Com. card] (r E E)

- **[Ref. 2 switching]** (r F C) is set to default value (**[Ref.1 Channel]** (F r I)).
- **[Profile]** (C H C F): defines if the drives operates in combined mode (reference and command from the same channel).

For the current example, **[Profile]** (C H C F) will be adjusted to **[Not separ.]** (S I N) as reference and control are originated from the communication network:

Profile	Ref1 Channel setting
CiA402 combined mode	[Not separ.] (S I N)
CiA402 separate mode	[Separate] (S E P)
I/O Profile	[I/O profile] (I O)

Configuration of the Drive for Operation with CiA402 Profile in Separate Mode

Alternate combinations are possible, see the ATV32 programming manual for the list of possible settings.

Example:

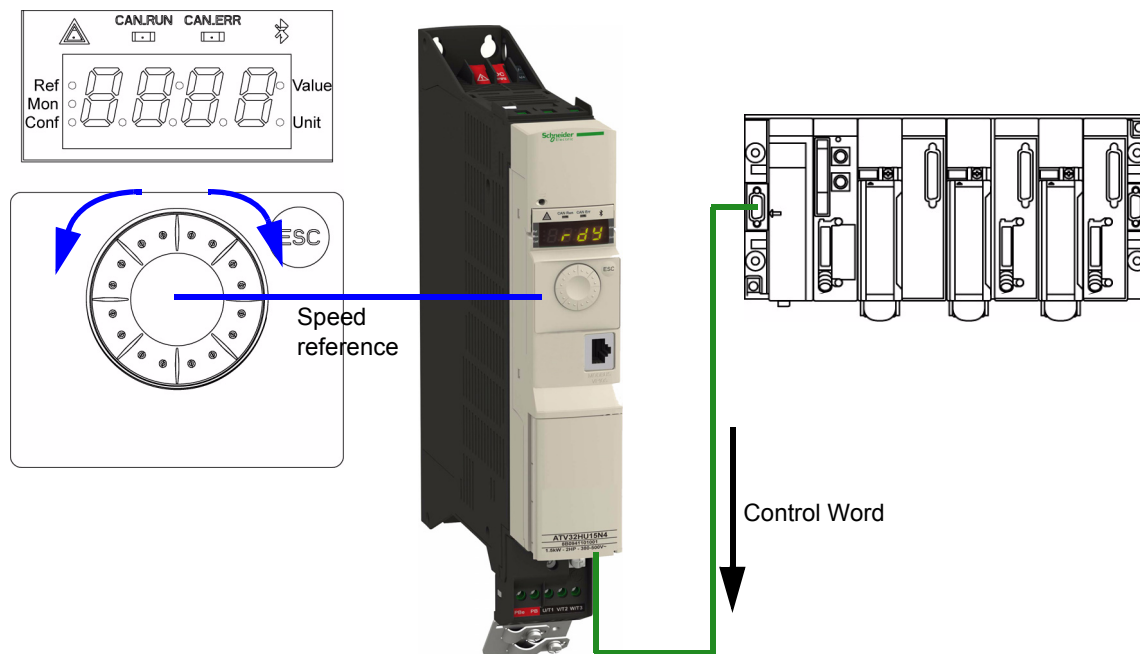

The drive is controlled from the communication (1 of the 3 following settings MDB, CAN or NET) but the reference is adjusted on local HMI. The control word comes from the controller and is written according to CiA402 profile.

The settings will be the following:

[Ref.1 channel] (F r I)	[Image input AIV1] (R I U I)
[Profile] (C H C F)	[Separate] (S E P)
[Cmd channel 1] (C d I)	[Com. card] (n E k)
[Ref. 2 switching] (r F C)	Default

Configuring Monitor Parameters

It is possible to select up to 4 parameters to display their values in the **[1.2 MONITORING]** menu on the graphic display terminal (to be ordered separately - reference VW3 A1 101).

The selection is made via the **[3. INTERFACE] / [3.3 MONITORING CONFIG.]** menu (**[COM. MAP CONFIG.]** submenu).

Each parameter in the range **[Word 1 add. select.] ... [Word 4 add. select.]** can be used to select the parameter logic address. An address at zero is used to disable the function.

Example

In the example given here, the monitored words are:

- Parameter 1 = Motor current (**L C r**): logic address 3204, signed decimal format.
- Parameter 2 = Motor torque (**D E r**): logic address 3205, signed decimal format.
- Parameter 3 = Last detected fault occurred (**L F E**): logic address 7121, hexadecimal format.
- Disabled parameter: 0; default format: Hexadecimal format

RDY	CAN	+0.00Hz	0A
COM. MAP CONFIG.			
Address 1 select	:		3204
FORMAT 1	:		Signed
Address 2 select	:		3205
FORMAT 2	:		Signed
Address 3 select	:		7121
Code		Quick	▼
FORMAT 3	:		Hex
Address 4 select	:		0
FORMAT 4	:		Hex

One of the three display formats below can be assigned to each monitored word:

Format	Range	Terminal display
Hexadecimal	0000 ... FFFF	[Hex]
Signed decimal	-32 767 ... 32 767	[Signed]
Unsigned decimal	0 ... 65 535	[Unsigned]

NOTE: If a monitored parameter:

- has been assigned to an unknown address,
- has been assigned to a protected parameter,
- has not been assigned,

the value displayed in the **[COMMUNICATION MAP]** screen is: "••••" (see "Diagnostic" on page 50).

Configuring Communication Interruption Management

The response of the drive in the event of a PROFIBUS communication interruption can be configured. It can be configured via the graphic display terminal or the integrated display terminal, from the Drive menu, **[Configuration]** (**C o n F**) menu, **[FULL]** (**F U L L**) menu, **[FAULT MANAGEMENT]** (**F L E -**) menu, **[COM. FAULT MANAGEMENT]** (**C L L -**) submenu, via the **[Network fault mgt]** (**C L L**) parameter.

RDY	NET	+0.00Hz	0A
COM. FAULT MANAGEMENT			<input type="checkbox"/>
Network fault mgt	:	Freewheel	
CANopen fault mgt	:	Freewheel	
Modbus fault mgt	:	Freewheel	
Code		Quick	<input type="checkbox"/>

The values of the **[Network fault mgt]** (**C L L**) parameter, which trigger a drive detected fault **[Com. network]** (**C n F**), are:

Value	Meaning
[Freewheel] (Y E 5)	Freewheel stop (factory setting)
[Ramp stop] (r n P)	Stop on ramp
[Fast stop] (F 5 E)	Fast stop
[DC injection] (d C I)	DC injection stop

The values of the **[Network fault mgt]** (**C L L**) parameter, which do not trigger a drive detected fault, are:

Value	Meaning
[Ignore] (n D)	Detected fault ignored
[Per STT] (5 E E)	Stop according to configuration of [Type of stop] (5 E E)
[fallback spd] (L F F)	Change to fallback speed, maintained as long as the detected fault persists and the run command has not been removed
[Spd maint.] (r L 5)	The drive maintains the speed at the time the detected fault occurred, as long as the detected fault persists and the run command has not been removed

The fallback speed can be configured in the **[FAULT MANAGEMENT]** (**F L E -**) / **[FALLBACK SPEED]** (**L F F -**) menu using the **[Fallback speed]** (**L F F**) parameter.

⚠ WARNING

LOSS OF CONTROL

If PROFIBUS fault management **[Network fault mgt]** (**C L L**) is set to **[Ignore]** (**n D**), communication control will be inhibited.

For safety reasons, inhibiting the communication interruption detection should be restricted to the debug phase or to special applications.

Failure to follow these instructions can result in death, serious injury, or equipment damage.

Telegram 100, 101 and 102



5

What's in this Chapter?

This chapter contains the following topics:

Topic	Page
Overview	28
Configuring an ATV32 With a Siemens© S7-315	30
Configuration of the Altivar 32 With the Telegram 100	31
Configuring an ATV32 With the Telegram 101 or 102	33
Parameters Management With 100, 101 and 102	34

Overview

The following diagram shows the natives modes for telegrams 100, 101 and 102:

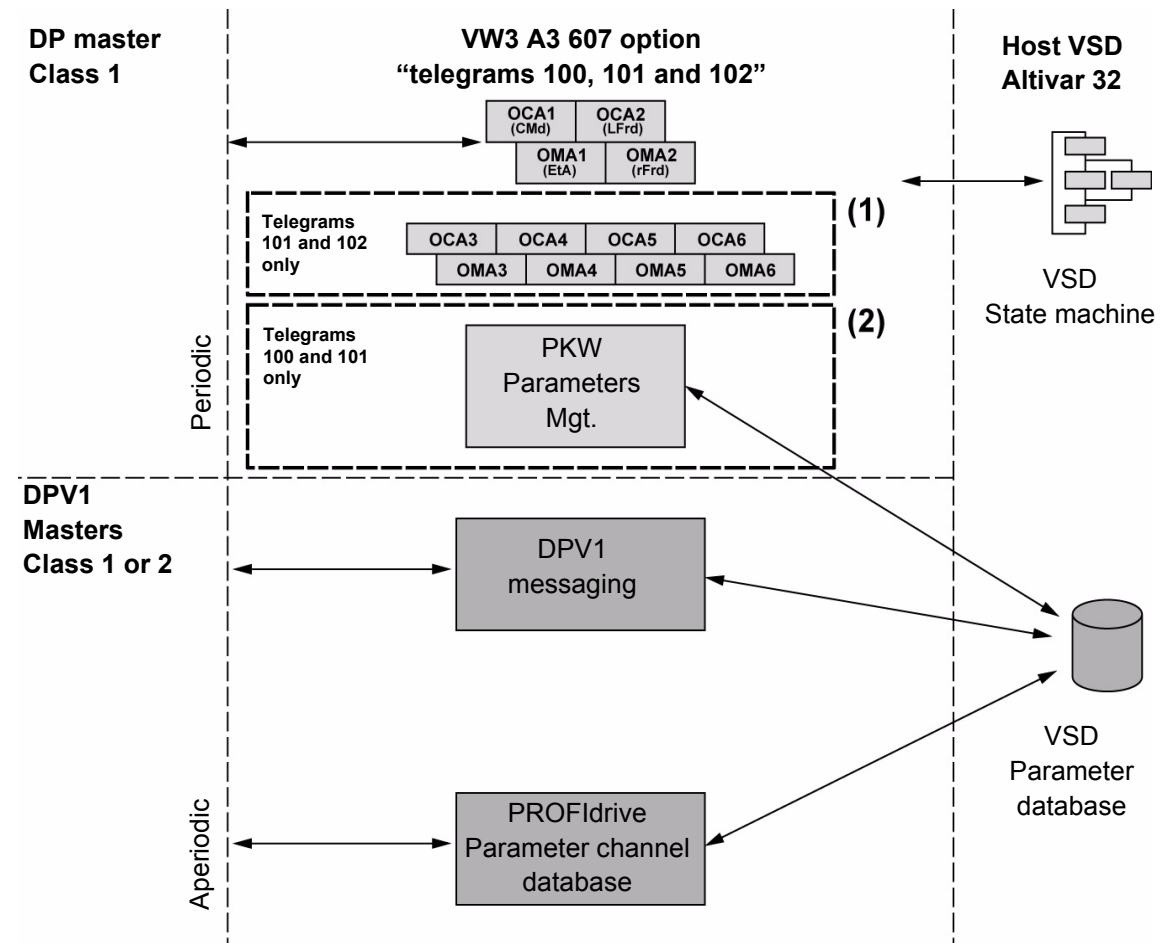

- (1) 4 additional parameters can be configured in the communication scanner.
 (2) PKW mechanism compliant with Altivar 71 and 312.

The native modes of the PROFIBUS VW3 A3 607 are used when telegrams 100,101 or 102 are used. The differences between these three modes are the following:

- Process data length varies: telegram 100 uses 2 cyclic datas whereas telegrams 101 and 102 use 6 cyclic datas.
- PKW area for parameters management: this area does not exist with telegram 102.

Native mode of the ATV32 is compliant with IEC 61800-7 (CiA402).

The PKW area of telegrams 100 and 102, which is used for a simple parameter management, is compliant with the PKW mechanism used with the PROFIBUS option cards of the ATV71/61 and ATV312.

Periodic Exchanges

The following table lists the mapping process of the periodic data according to the chosen telegram:

	Telegram 100		Telegram 101		Telegram 102	
	Master>Device	Device>Master	Master>Device	Device>Master	Master>Device	Device>Master
PKW 1	PKE	PKE	PKE	PKE		
PKW 2	R/W	R/W	R/W	R/W		
PKW 3	PWE	PWE	PWE	PWE		
PKW 4	PWE	PWE	PWE	PWE		
Cyclic data 1	OCA1 Address of CMD =8501*	OMA1 Address of ETA =3201*	OCA1 Address of CMD =8501*	OMA1 Address of ETA =3201*	OCA1 Address of CMD =8501*	OMA1 Address of ETA =3201*
Cyclic data 2	OCA2 Address of LFRD =8602*	OMA2 Address of RFRD =8604*	OCA2 Address of LFRD =8602*	OMA2 Address of RFRD =8604*	OCA2 Address of LFRD =8602*	OMA2 Address of RFRD =8604*
Cyclic data 3			OCA3 Default =0	OMA3 Default =0	OCA3 Default =0	OMA3 Default =0
Cyclic data 4			OCA4 Default =0	OMA4 Default =0	OCA4 Default =0	OMA4 Default =0
Cyclic data 5			OCA5 Default =0	OMA5 Default =0	OCA5 Default =0	OMA5 Default =0
Cyclic data 6			OCA6 Default =0	OMA6 Default =0	OCA6 Default =0	OMA6 Default =0

*:default Modbus address.

The configuration of the cyclic data is made with the PROFIBUS DP master configuration tool. The Modbus address of the parameter linked to each cyclic data must be defined as in the following example with the HW configuration software:

Input cyclic data 1/2 and output cyclic data 0/1 are already preconfigured to (**C M D**) (8501) and (**L F R D**) (8602); (**E T A**) (3201) and (**r F r d**) (8604).

If a null address Modbus is entered, no link between the related cyclic data and the drive will be established. In any case the six cyclic datas are not disabled and the six cyclic datas will take place in the I/O memory image of the master.

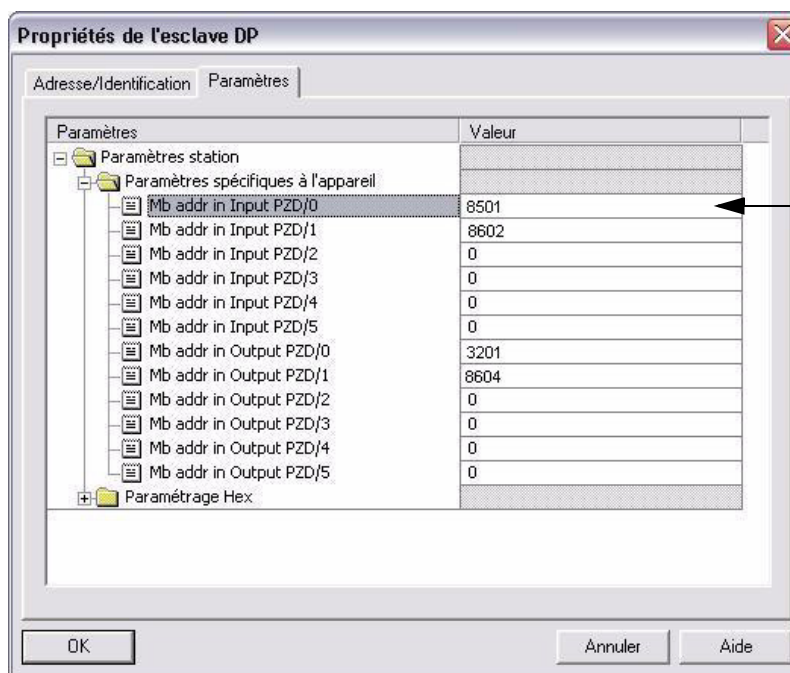

The Modbus address is entered in this field

When the exchanges are performed (PROFIBUS network is running) you can check the configured parameters by reading from the ATV32 HMI the configured Modbus address: with the (**O C R x**) and (**O P R x**) parameter in the PROFIBUS option menu of the drive.

Configuring an ATV32 With a Siemens© S7-315

GSD Installation

First, you need to download and install the GSD file of the ATV32 in the Hardware Configuration tool of The SIMATIC STEP7® software. You can find the GSD file and its associated picture on www.schneider-electric.com

From the menu > Option > Install New GSD as follows:

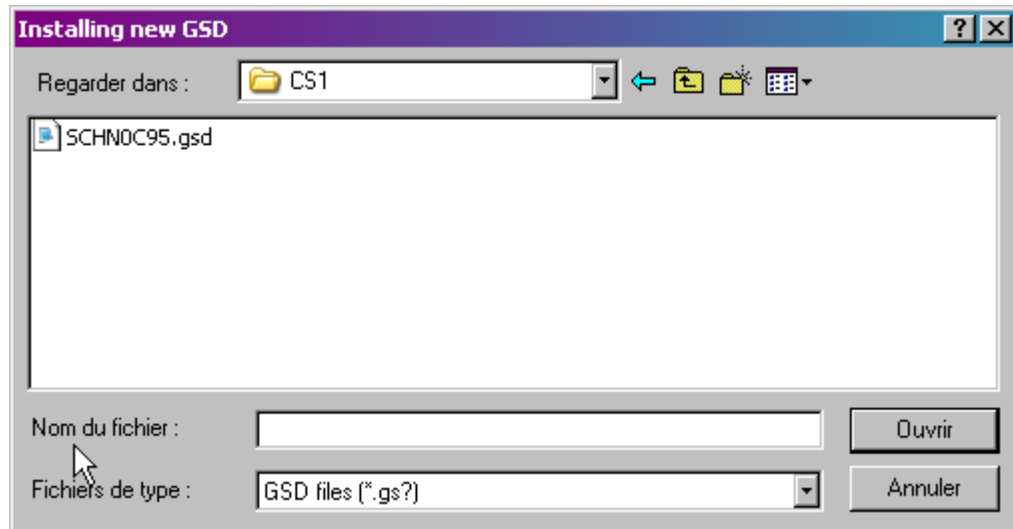

Once installed you should see the Altivar 32, in the library, as follows:

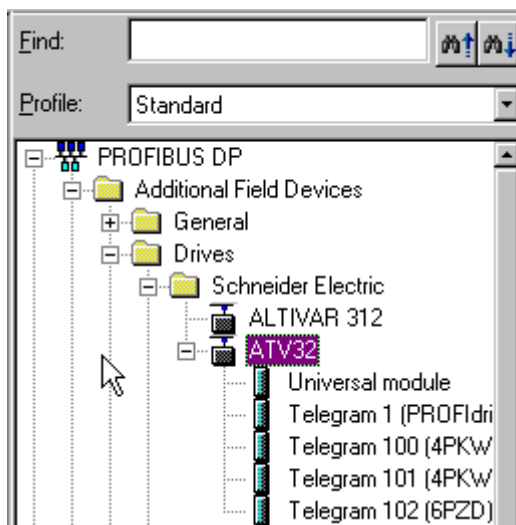

Configuration of the Altivar 32 With the Telegram 100

With this telegram, the Altivar 32 is controlled with 2 process data. In addition 4 read and 4 write cyclic data can be used to read or write Altivar 312 parameters.

Configure the Master PLC and its PROFIBUS DP network. Then, drag and drop the Altivar 32 from the library to the Bus:

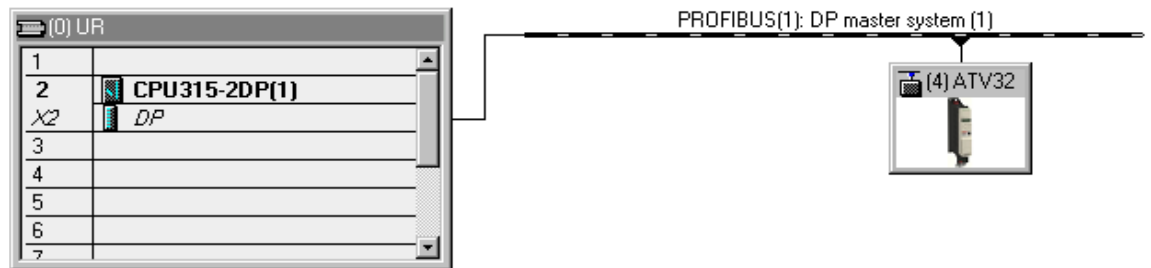

Define the addresses of the cyclic data and PKW data in the PLC periphery:

The screenshot shows the 'HW Config' software interface. The 'Properties - DP slave' dialog box is open, showing the following configuration:

- Address / ID:** (Empty)
- I/O Type:** Out-input
- Output:**
 - Start: 264
 - End: 267
 - Length: 2
 - Unit: Words
 - Consistent over: Total length
- Input:**
 - Start: 264
 - End: 267
 - Length: 2
 - Unit: Words
 - Consistent over: Total length

At the bottom, a table shows the configuration for slot 2:

Slot	Order Number / Designation
1	4AX Telegram 100 (4PKW/2FZD)
2	24 -> Telegram 100 (4FKW/2FZD)

By default, the process data are linked to (*C P d*), (*L F r d*), (*E L R*) and (*r F r d*) (native CiA402 profile of the drive). You can check that the exchanges are working properly by the Monitor / Modify function of the configuration tool:

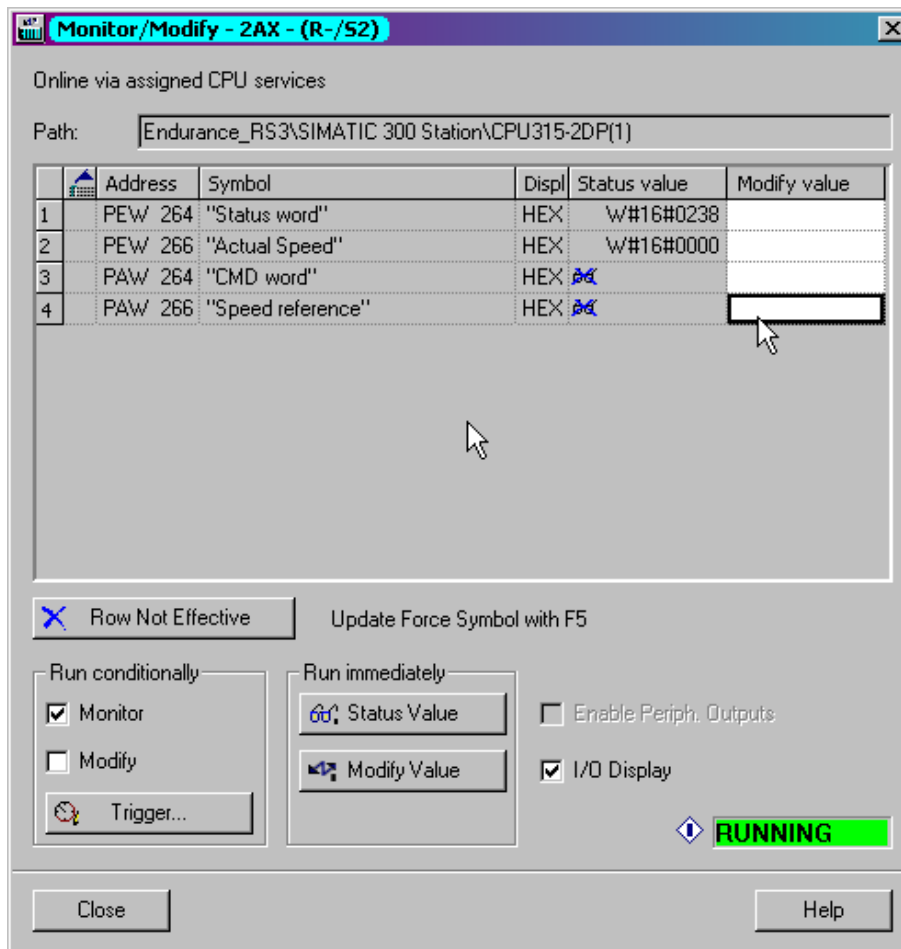

Configuring an ATV32 With the Telegram 101 or 102

Configuring the Drive Communication Scanner

The configuration of the option card communication is defined by the master, by default the 2 first read and write are linked to the default parameters: (C P d), (L F r d), (E t R) and (r F r d). The 4 next read or write parameters are not configured. To add new parameters or modify the default configuration of the communication scanner, open the properties dialog box of the slave device and configure the OCA/OMA values in the parameter assignment tab.

The screenshot shows the 'Properties - DP slave' dialog box with the following parameter assignment table:

Parameters	Value
Station parameters	
Device-specific parameters	
OCA1	8501
OCA2	8602
OCA3	0
OCA4	0
OCA5	0
OCA6	0
OMA1	3201
OMA2	8604
OMA3	9001
OMA4	0
OMA5	0
OMA6	0
Hex parameter assignment	

New parameters are added or modified by typing their internal Modbus address.

In the example here (O P A 3) is configured to read the value of (R C C), which Modbus Addresses is 9001.

Parameters Management With 100, 101 and 102

In native modes several access to the Drive parameters are possible:

- The standard acyclic requests from PROFIdrive (described in the “Annex B - The PROFIdrive Parameters Channel” on page 60)
- PKW mechanisms — consistent with Altivar 71 and Altivar 312. (When PROFIBUS Master supports only DP V0 services).
- A DP V1 Schneider-Electric specific method.

Parameter Management Through the PKW Area

With telegrams 100 and 102, you can read or write any drive parameter by using this PKW area. (This addressing scheme is identical to the PKW mechanism of the Altivar 71 and Altivar 32).

NOTE: The management of the parameters (compatibility with series 1 product) is Schneider Electric specific. Actually, previous versions of PROFIdrive (<V2.0) specified also parameters management through PKW, are not compatible with Schneider Electric method. In recent versions, parameters are managed with acyclic messages, and the PNO PKW method is obsolete

The PKW area is made of four input words and four output words.

The following table lists the controller-to-drive parameters in the input PKW area:

PKW nr	PKW1	PKW2	PKW3	PKW4
PKE Name	PKE	R/W	PWE	PWE
Description	The Modbus address of the parameter is detailed here.	Request code: 0: no request 1: read 2: write	Not used	Parameter value

The following table lists the drive-to-controller parameters in the output PKW area:

PKW nr	PKW1	PKW2	PKW3	PKW4
PKE Name	PKE	R/W	PWE	PWE
Description	Copy of the input PKE	Request code: 0: no request 1: read done 2: write done 7: read or write error	Not used	If the request is successful the parameter value is copied here.

DP V1 / Acyclic Messaging - Schneider-Electric Specific

The PROFIBUS DPV1 telegram includes a header, described in the following diagram:

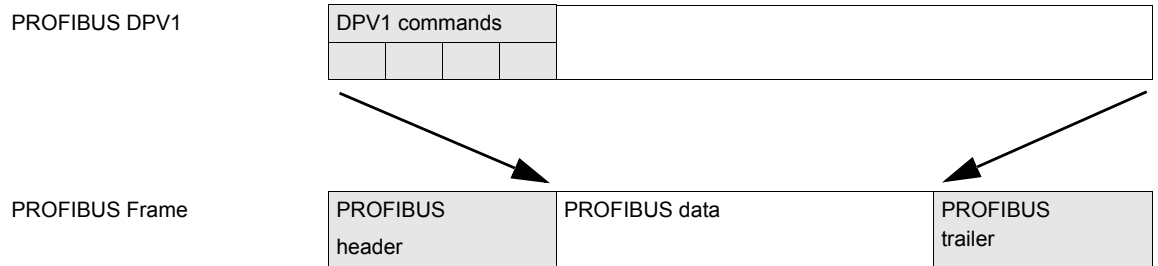

The following table lists the content of the DPV1 header:

DU	Byte - nr
Function code	0
Slot_num	1
Index	2
Length	3
data	4-5

An indirection mechanism is used:

- Step 1:

DU	Bytes	Request	Positive answer	Negative answer
Function code	0	16#5E (read) 16#5F (write)	16#5E (read) 16#5F (write)	16#DF (read) / 16#DE (write)
Slot_num	1	1	1	16#80
Index	2	16#E9	16#E9	16#XX (Error type)
Length	3	2	-	16#YY (Error type)
data	4-5	16#ZZZZ (ZZZZ is the Modbus address)	-	0

- Step 2:

DU	Bytes	Request	Positive answer	Negative answer
Function code	0	16#5E (read) 16#5F (write)	16#5E (read) 16#5F (write)	16#DF (read) / 16#DE (write)
Slot_num	1	1	1	16#80
Index	2	16#EA	16#E9	16#XX (Error type)
Length	3	2	-	16#YY (Error type)
data	4-5	- Read: - - Write: 16#0010	-	0

Network: 3

Reading

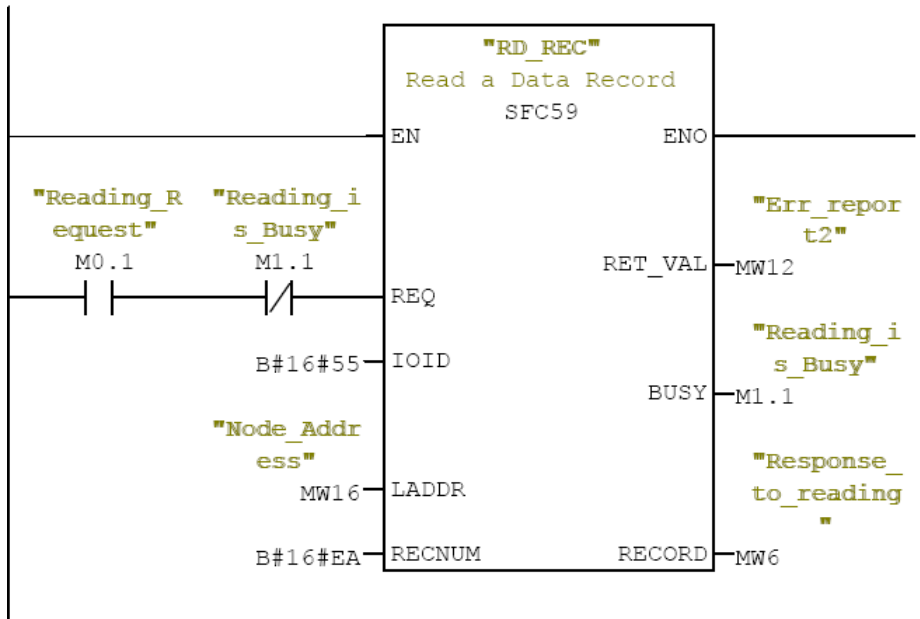

Network: 4

Writing

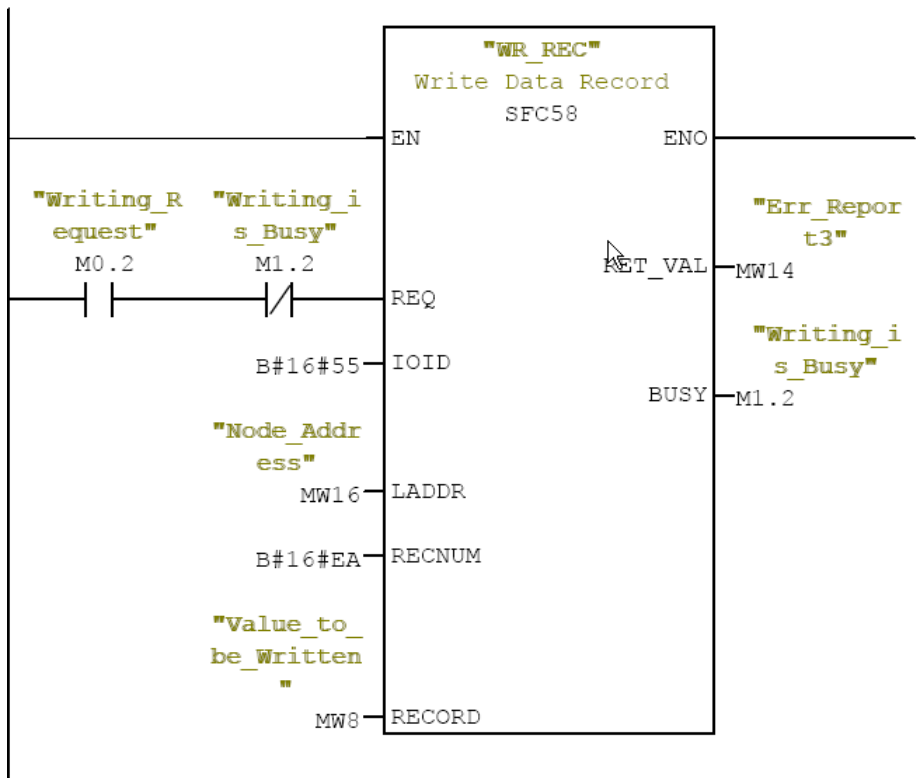

Telegram 1

**6**

What's in this Chapter?

This chapter contains the following topics:

Topic	Page
Overview	39
State Diagram	40
Command Word and Status Word	41
Speed Setpoint	44
DP V1 - PROFIdrive / Acyclic Messaging	44

Overview

The following diagram shows the operating modes:

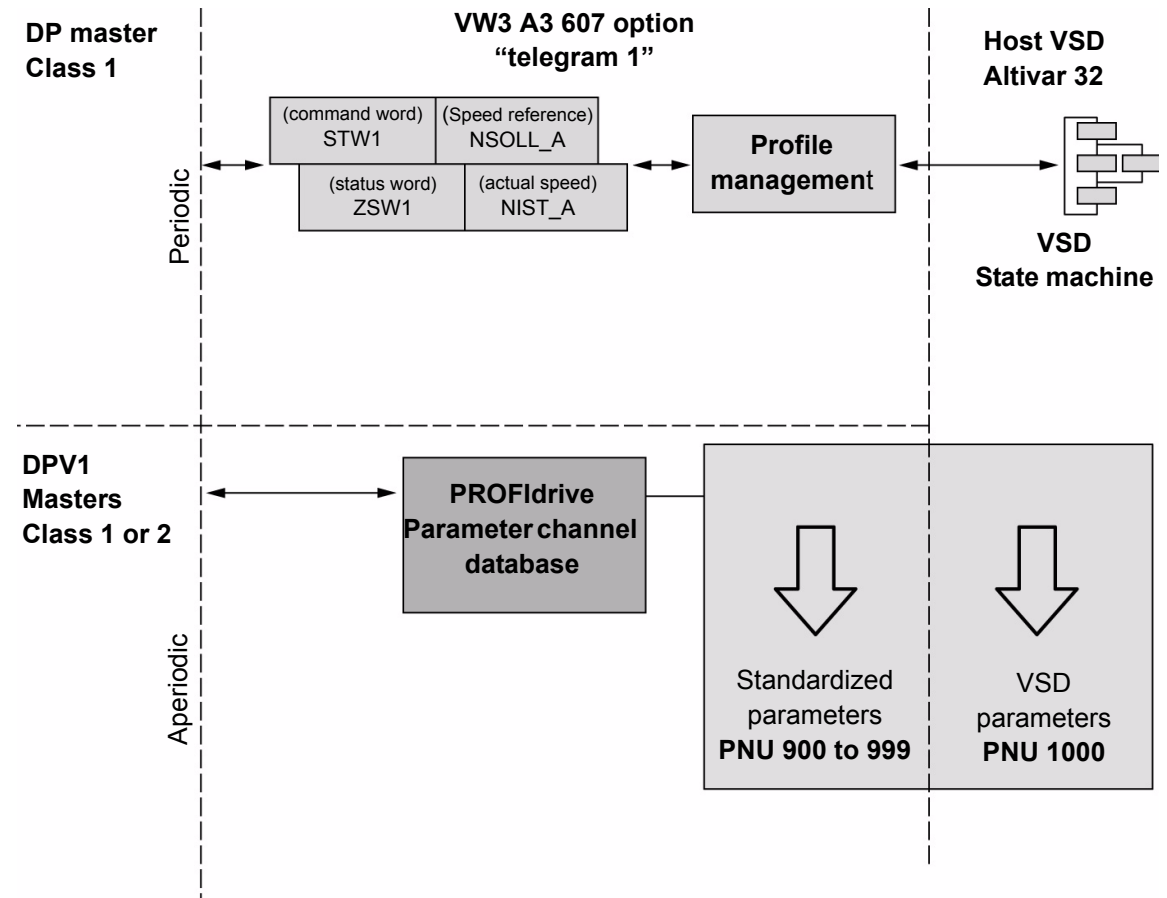

The following section describes how the VW3 A3 607 is operated when configured in PROFIdrive mode (telegram 1).

NOTE: This mode is based on PROFIdrive but it doesn't support it to 100%.

The selection of this mode is done while configuring the slave device with the PROFIBUS network configuration tool.

It is out of the scope of this document to describe how to use such tool. However, you can find in the examples (see "Configuring an ATV32 With a Siemens® S7-315" on page 30) how to configure the card for the Schneider PLCs and for the SIMATIC® S7 PLCs.

NOTE: From the Altivar 32 side, the only parameter to define is the slave address of the variable speed drive on the PROFIBUS DP network. This is described in the "Setup" on page 18.

Periodic Exchanges

The periodic exchanges, with PROFIdrive application class A profile consists of:

- 16 bit command word (STW1) and 16 bit reference word (NSOLL_A),
- 16 bit status word (ZSW1) and 16 bits actual velocity word (NIST_A).

The mapping of these words is automatically done when you select Telegram 1 during the configuration of the device.

State Diagram

The following state diagram shows the PROFIdrive state machine for the application class 1. The diagram also describes the command word and status word.

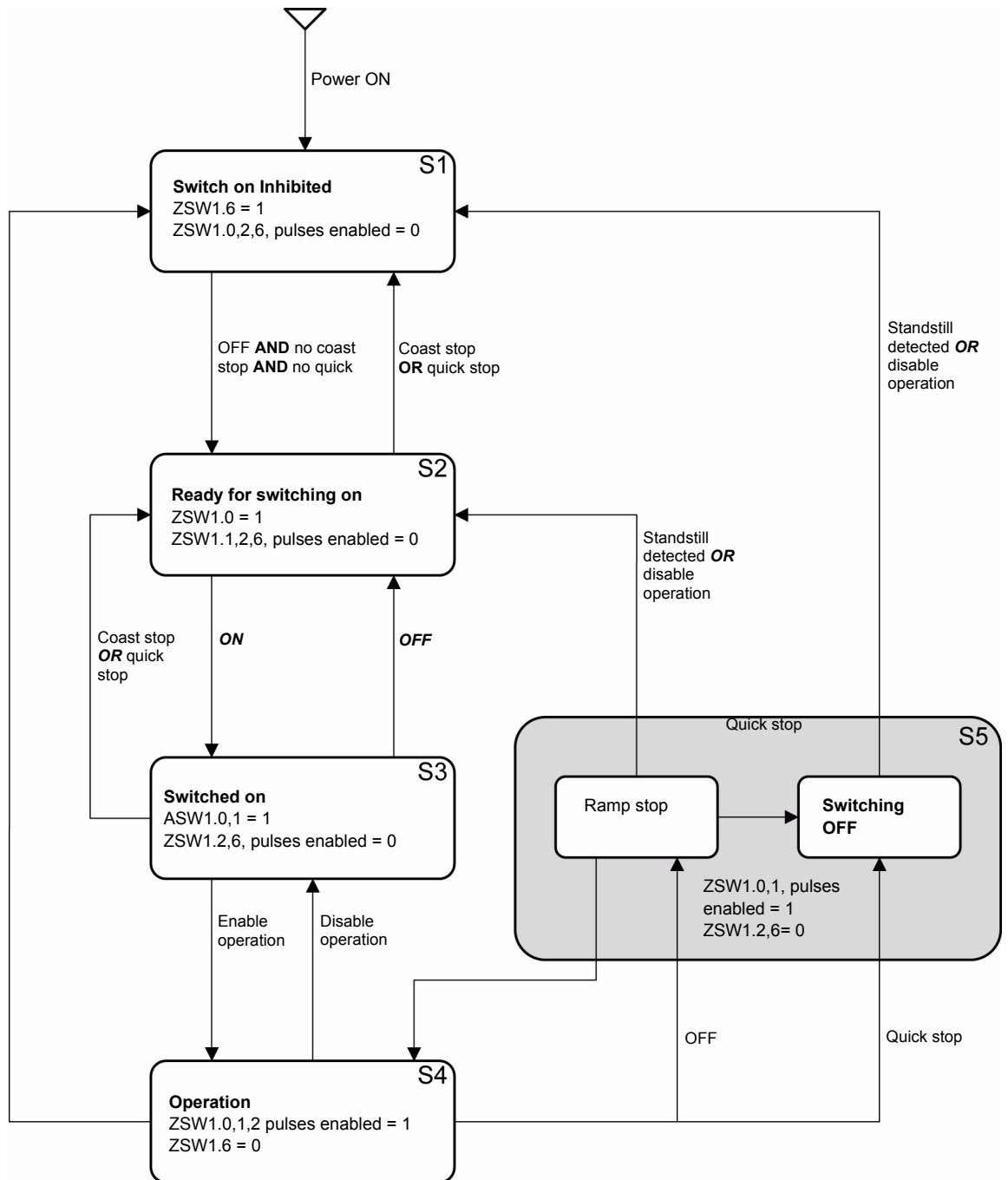

Command Word and Status Word

Overview

The following table lists the command wording from PROFIdrive application profile class 1:

STW1							
Bit 7	Bit 6	Bit 5	Bit 4	Bit 3	Bit 2	Bit 1	Bit 0
Detected fault Acknowledge	-	-	-	Enable operation	Quick stop	Coast stop	ON/OFF
Bit 15	Bit 14	Bit 13	Bit 12	Bit 11	Bit 10	Bit 9	Bit 8
-	-	-	-	-	Control and reference by PLC	-	-

The following table lists the status from PROFIdrive application profile class 1:

ZSW1							
Bit 7	Bit 6	Bit 5	Bit 4	Bit 3	Bit 2	Bit 1	Bit 0
Warning	Switching inhibited	Quick stop Not activated	Coast stop Not activated	Detected fault present	Operation enabled	Ready to operate	Ready to switch ON
Bit 15	Bit 14	Bit 13	Bit 12	Bit 11	Bit 10	Bit 9	Bit 8
-	reserved	reserved	reserved	reserved	F or n reached or exceeded	Control requested	Speed error within tolerance range

Command Word Details

The following table gives the detailed definitions of the STW1 command words:

STW1			
Bit 0	ON	1	“Switched on” condition; voltage at the power converter, i.e. the main Contact is closed (if present).
	OFF (OFF 1)	0	Power-down (the drive returns to the “ready for switching on “ condition); the drive is ramped-down along the ramp (RFG) or along the current limit or along the voltage limit of the d.c. link; if standstill is detected, the voltage is isolated; the main contact is opened (if present). During deceleration bit 1 of ZSW1 is still set. An OFF command is interruptible.
Bit 1	No coast stop	1	All “Coast Stop (OFF2)” commands are withdrawn.
	Coast stop (OFF 2)	0	Voltage is isolated. The main contact is then opened (if present) and the drive goes into the “Switching On Inhibited” condition; the motor coasts down to a standstill.
Bit 2	No quick stop	1	All “Quick Stop (OFF3)” commands are withdrawn.
	Quick stop (OFF 3)	0	Quick stop; if required, withdraw the operating enable, the drive is decelerated as fast as possible, e.g. along the current limit or at the voltage limit of the d.c. link, at $n / f = 0$; if the rectifier pulses are disabled, the voltage is isolated (the contact is opened) and the drive goes into the “Switching On Inhibited” condition. A Quick Stop command is not interruptible.
Bit 3	Enable operation	1	Enable electronics and pulses. The drive then runs-up to the setpoint.
	Disable operation	0	The drive coasts down to a standstill (ramp-function generator to 0 or tracking) and goes into the “Switched on” condition (refer to control word 1, bit 0).
Bit 4	reserved		
Bit 5	reserved		
Bit 6	Not used		
Bit 7	Detected fault acknowledgement	1	The group signal is acknowledged with a positive edge; the drive reaction to a detected fault depends on the type of detected fault. If the detected fault reaction has isolated the voltage, the drive then goes into the “Switching On Inhibited “ condition.
Bit 8	Not used		
Bit 9	Not used		
Bit 10	Control by PLC	1	Setpoint and control from the bus are active.
	No Control by PLC	0	Setpoint and control from the bus are NOT active.
Bit 11	reserved		
Bit 12	reserved		
Bit 13	reserved		
Bit 14	reserved		
Bit 15	reserved		

Status Word

The following table gives the detailed status defined by the ZSW1 command words:

ZSW1			
Bit 0	Ready to Switch ON	1	Power supply is switched on, electronics initialized, main contact, if available, has dropped out, pulses are inhibited.
	Not ready to Switch ON	0	-
Bit 1	Ready to operate	1	Refer to control word 1, bit 0.
	Not ready to operate	0	-
Bit 2	Operation enabled	1	Drive follows setpoint. This means, that the electronic and pulses are enabled (Refer to control word 1, bit 3), the closed loop control is active and controls the motor and the output of the setpoint channel is the input for the closed loop control.
		0	Either the pulses are disabled or the drive doesn't follow the setpoint.
Bit 3	Detected fault present	1	Unacknowledged detected faults or currently not acknowledge able detected faults (fault messages) are present (in the fault buffer). The detected fault reaction is fault-specific and device-specific. The acknowledging of a detected fault may only be successful, if the detected fault cause has disappeared or has been removed before. If the detected fault has isolated the voltage, the drive goes into the "Switching On Inhibited" condition, otherwise the drive returns to operation. The related detected fault numbers are in the detected fault buffer.
	No detected fault present	0	-
Bit 4	Coast stop not activated	1	-
	Coast stop activated	0	Coast Stop (OFF 2) command is present.
Bit 5	Quick stop not activated	1	-
	Quick stop activated	0	Quick Stop (OFF 3) command is present.
Bit 6	Switching Inhibited	1	The drive goes only again in the "Switched On" condition with "No Coast Stop AND No Quick Stop" followed by "ON". This means that the "Switching On Inhibited" bit is only set back to zero if the OFF command is set after "No Coast Stop AND No Quick Stop".
	Switching not inhibited	0	-
Bit 7	Warning present	1	Warning information present in the service/maintenance parameter; no acknowledgement.
	No warning	0	-
Bit 8	Speed error within tolerance range	1	Actual value is within a tolerance band; dynamic violations are permissible.
	Speed error out of tolerance range	0	-
Bit 9	Control requested	1	The automation system is requested to assume control.
	No Control requested	0	Control by the automation system is not possible, only possible at the device level, by another interface or the drive is controlled from a supervisor (Master class 2).
Bit 10	F or n reached or exceeded	1	Actual value \geq comparison value (setpoint) which may be set via the parameter number.
	F or n not reached	0	-
Bit 11	reserved		
Bit 12	reserved		
Bit 13	reserved		
Bit 14	reserved		
Bit 15	reserved		

Speed Setpoint

Speed Setpoint Channel

The speed setpoint, written in NSOLL_A, gives a frequency output defined by the following formula:

$$\text{Speed setpoint in Hz} = (\text{NSOLL_A} \times [\text{Max frequency}] (F_r)) / 16\#4000$$

[Max frequency] (F_r): Normalized frequency of the ATV32 (typically 50Hz).

Speed Setpoint Range

The following table lists the different values for the speed references and the correspondence for ATV32:

Setpoint value	Setpoint used by the Altivar 32
16#0000	0
16#4000	100% of normalized frequency
16#C000	-100% of normalized frequency
16#8001	-200% of normalized frequency
16#7FFF	200% of normalized frequency

DP V1 - PROFIdrive / Acyclic Messaging

See "Annex B - The PROFIdrive Parameters Channel" on page 60

Common Additional Features



What's in this Chapter?

This chapter contains the following topics:

Topic	Page
Identification and Maintenance Data	46
I&M Records Description	47

Identification and Maintenance Data

Identification & maintenance (I&M) has been established to the PNO. "Support the end-user during the various scenario of the device's lifecycle":

- Configuration
- Commissioning
- Repair and update
- Operation and visualization

NOTE: These fields are read only.

The access to the I&M records is achieved by the use of the PROFIBUS DPV1 mechanisms (IEC 611458-6). The read and write calls uses index 255 for I&M.

I&M Records Description

Champ	Number of bytes	Value	Meaning
Header_Manuf_spec	10	VW3 A3 607	(string) Option board commercial reference
Manufacturer_ID	2	16#01, 16#29	16#129 ' Schneider Electric
ORDER_ID	20	Identification object ID 1	Commercial reference of the DRIVE
SERIAL_NUMBER	16	Serial number	C1P1, C1P2, C1P3, C1P4
HARDWARE_REVISION	2	16#10, 16#00	-
SOFTWARE_REVISION	4	'V', A, B, C	A = MSB of C1SV B = LSB of C1SV C = MSB of C1SB
REVISION_COUNTER	2	16#00, 16#00	Rev 0
PROFILE_ID	2	-	Defined by the PNO (3A00..3AFF, PROFIdrive)
PROFILE_SPECIFIC_TYPE	2	-	Profile specific number
IM_VERSION	2	16#01, 16#01	Version I&M: 1.1
IM_SUPPORTED	2	16#00, 16#01	Managed Index I&M ' I&M0

The ORDER_ID contains the commercial reference of the drive. The commercial reference of the option will be stored in the Manufacturer specific field.

Diagnostic and Monitoring



8

What's in this Chapter?

This chapter contains the following topics:

Topic	Page
PROFIBUS Interface Settings	49
Diagnostic	50
Monitoring of Communication Channels	52

PROFIBUS Interface Settings

LED Diagnostic

The following picture shows the location of the two LEDs dedicated to PROFIBUS:

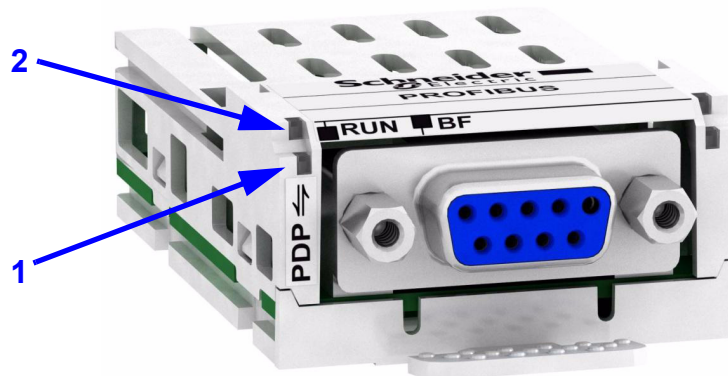

1: "RUN" LED (green)	2: "BF" LED (red)	Meaning
Off	Off	Fieldbus communication inactive
On	Off	Fieldbus communication active
Off	On	Fieldbus error (e.g. watchdog)
Off	Flashes	Incorrect parameterization

Fieldbus Function Test

If the connections are correct, check the settings for the fieldbus addresses. After correct configuration of the transmission data, test the fieldbus mode.

In addition to the master that knows the product via the data in the GSD file and the address, a bus monitor should be installed. As a passive device, it can display messages.

- Switch off or on the supply voltage of the drive system.
- Observe the network messages shortly after switching on the drive system. A bus monitor can be used to record the elapsed time between telegrams and the relevant information in the telegram.

Possible Errors: Addressing, Parameterization, Configuration

If it is impossible to connect to a device, check the following:

- Addressing: The address of the network device must be between 2 and 126. Each network device must have a unique address.
- Parameterization: The parameterized Ident number and the user parameters must match the values stored in the GSD file.
- Configuration: The data length in input and output direction must be identical to the length specified in the GSD file.

Diagnostic

CnF and ILF Detected Faults

The following table lists the time-out parameters:

Parameter	Description	Possible Values	Terminal Display	Default Value
[Com. network] (<i>C n F</i>)	This detected fault is used to indicate that a network detected fault has occurred. When the detected fault occurs, the option position the CNF parameter to the value corresponding to the detected fault. When the detected fault has disappeared, the option writes the CNF parameter to 0	0 No detected fault 1 Timeout on periodic reception 2 Identification error between the Option and the master 3 Master in clear mode 4 Master class 2 timeout	[0] (0) [1] (1) [2] (2) [3] (3) [4] (4)	[0] (0)
[Int. com. link] (<i>I L F</i>)	This detected fault indicates an internal trip and can be cleared. It needs a Power Off / Power On to remove the detected fault	0 No detected fault 1 Loss of internal communication 2 Hardware malfunction	[0] (0) [1] (1) [2] (2)	[0] (0)

Diagnostic (DP V1 Service)

DPV1 diagnostic are associated with specific data which can be helpful during maintenance:

- The detected fault code, if a detected fault is present,
- The value of ETA,
- The value of the speed.

This data report and gives an indication on the drive status when the diagnostic event was triggered.

Diagnostic information Read:

byte	Description	
1...6	reserved	
7	Ext_Diag_Data	External diagnostic data length = 6
8		IF ETA.bit 3 = 1: ADL LFT LSB Otherwise: 0
9		ADL ETA LSB
10		ADL ETA MSB
11		LSB of the last value of the output speed
12		MSB of the last value of the output speed

Enabling Extended Diagnostics

By default, extended diagnostics are disabled. It can be activated during the configuration phase as shown below:

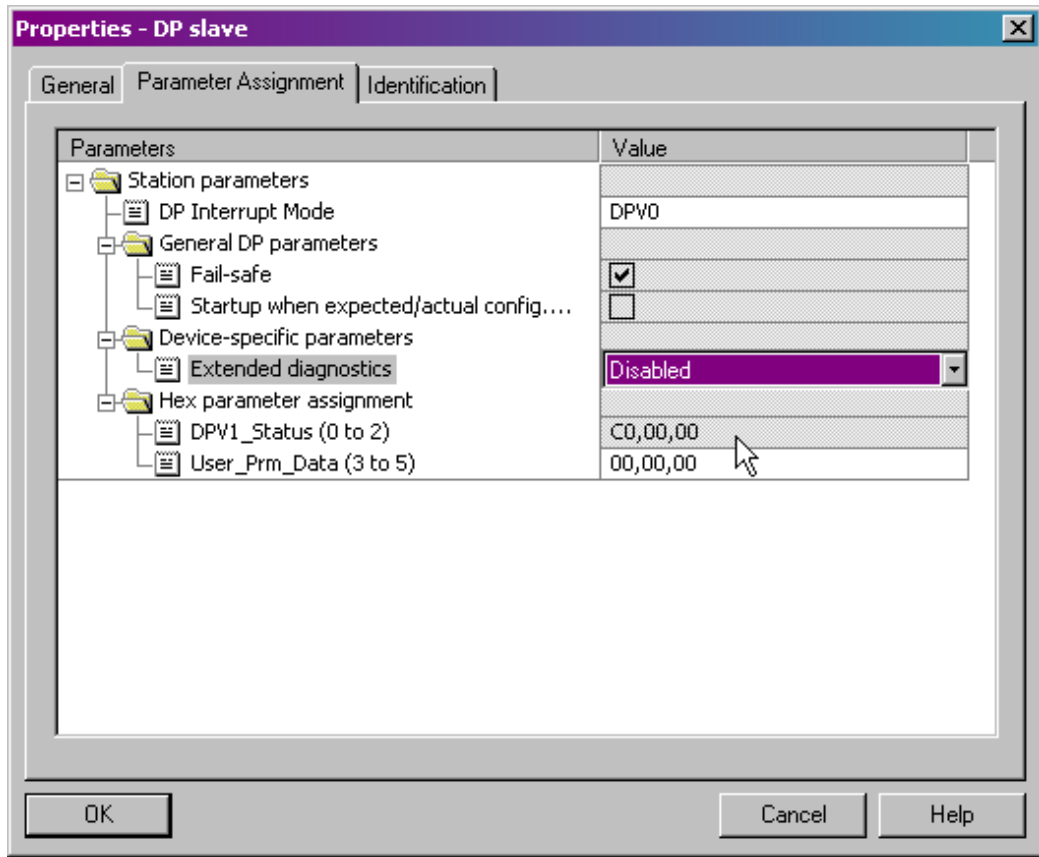

Monitoring of Communication Channels

Command and Reference Channels

All the drive's command and reference parameters are managed on a channel-by-channel basis.

It is possible to identify the last value written for each channel and each command or reference parameter:

Parameter name	Parameter code			
	Taken into account by the drive	Modbus	CANopen	Communication card
Control word	(C Nd)	(C Nd 1)	(C Nd 2)	(C Nd 3)
Extended control word	(C N 1)	(C N 1 1)	(C N 1 2)	(C N 1 3)
Speed reference (rpm)	(L Fr d)	(L Fr d 1)	(L Fr d 2)	(L Fr d 3)
Frequency reference (0.1 Hz)	(L Fr)	(L Fr 1)	(L Fr 2)	(L Fr 3)
PI regulator reference	(P ISP)	(P Ir 1)	(P Ir 2)	(P Ir 3)
Analog multiplier reference	(N Fr)	(N Fr 1)	(N Fr 2)	(N Fr 3)

Network Monitoring Criteria

The network is monitored according to the protocol-specific criteria.

Protocol	Criteria	Related detected fault
Integrated Modbus port	Adjustable time-out for received requests destined for the drive.	[Modbus fault] (5 L F)
PROFIBUS DP card	Adjustable time-out (via the network configuration software) for received periodic variables (cyclic data and PKW) destined for the drive	-

Monitoring of Communication Channels

Communication channels are monitored if they are involved in one of the following parameters:

- The control word ([Cmd value] (C Nd)) from the active command channel
- The control word containing the command switch (bit configured on [Cmd switching] (C C 5))
- The control word containing the switch for reference 1'1B (bit configured on [Ref 1B switching] (r C b))
- The control word containing the switch for reference 1'2 (bit configured on [Ref. 2 switching] (r F C))
- The frequency or speed reference ([HMI Frequency ref.] (L Fr) or LFRD: Nominal speed value) from the active reference channel
- Summing frequency or speed reference ([HMI Frequency ref.] (L Fr) or LFRD: Nominal speed value) 2 (assigned to [Summing ref. 2] (S R 2))
- Summing frequency or speed reference ([HMI Frequency ref.] (L Fr) or LFRD: Nominal speed value) 3 (assigned to [Summing ref. 3] (S R 2))
- Subtracting frequency or speed reference ([HMI Frequency ref.] (L Fr) or LFRD: Nominal speed value) 2 (assigned to [Subtract ref. 2] (d R 2))
- Subtracting frequency or speed reference ([HMI Frequency ref.] (L Fr) or LFRD: Nominal speed value) 3 (assigned to [Subtract ref. 3] (d R 3))
- The PID regulator reference (PISP)
- The PID regulator feedback ([AI Virtual 2] (R IU 2))
- The reference multiplication coefficient ([Multiplying coeff.] (N Fr)) 2 (assigned to [Multiplier ref. 2] (N R 2))
- The reference multiplication coefficient ([Multiplying coeff.] (N Fr)) 3 (assigned to [Multiplier ref. 3] (N R 3))

As soon as one of these parameters has been written once to a communication channel, it activates monitoring for that channel.

If a communication alarm is sent (in accordance with the protocol criteria) by a monitored port or network card, the drive will trigger a communication interruption.

The drive reacts according to the communication interruption configuration (detected fault, maintenance, fallback, etc.)

If a communication alarm occurs on a channel that is not being monitored, the drive will not trigger a communication interruption.

Enabling of Communication Channels

A communication channel is enabled once all the parameters involved have been written at least one time. The drive is only able to start if all channels involved in command and reference are enabled.

Example:

A drive in DSP402 profile is connected to an active communication channel.

It is mandatory to write at least one time the reference and the command in order to switch from “4-Switched on” to “5-Operation enabled” state.

A communication channel is disabled:

- In the event of a communication alarm
- In “forced local” mode.

Note: On exiting “forced local” mode:

- The drive copies the run commands, the direction and the forced local reference to the active channel (maintained).
- Monitoring of the active command and reference channels resumes following a time delay **[Time-out forc. local] (F L D E)**.
- Drive control only takes effect once the drive has received the reference and the command from the active channel.

Annexes



9

What's in this Chapter?

This chapter contains the following topics:

Topic	Page
Annex A - Simple CONT Language FC (Controlling the Drive in CiA402 Mode)	55
Annex B - The PROFIdrive Parameters Channel	60

Annex A - Simple CONT Language FC (Controlling the Drive in CiA402 Mode)

Block: FC1

Network: 1
 rising edge on start command

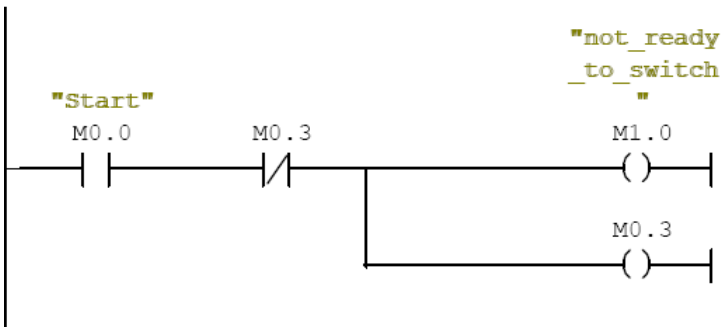

Network: 2

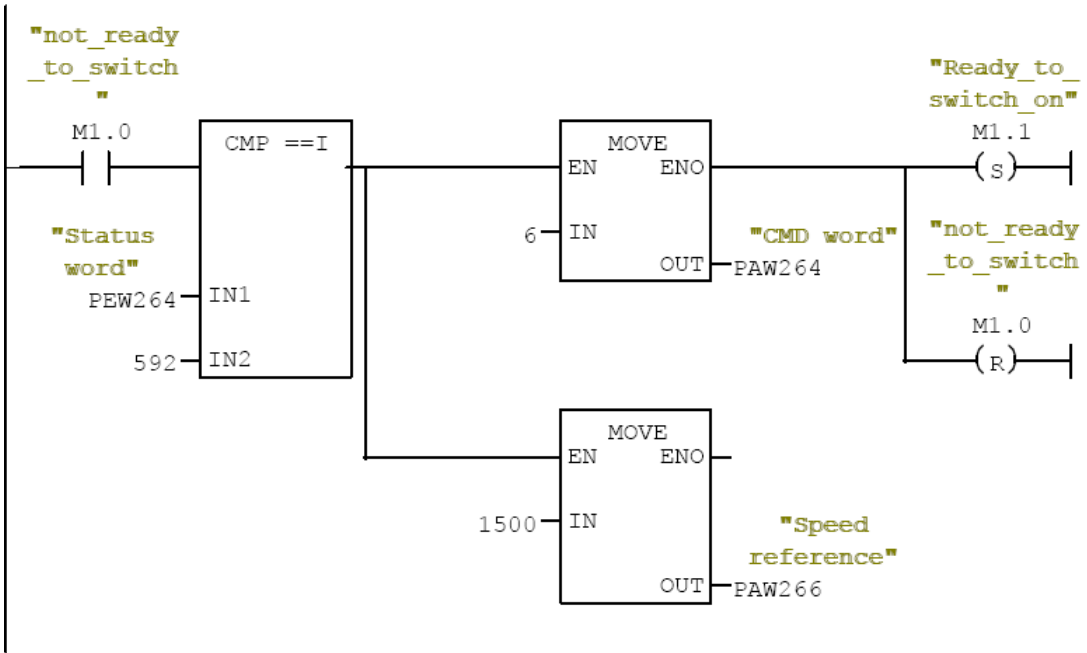

Network: 3

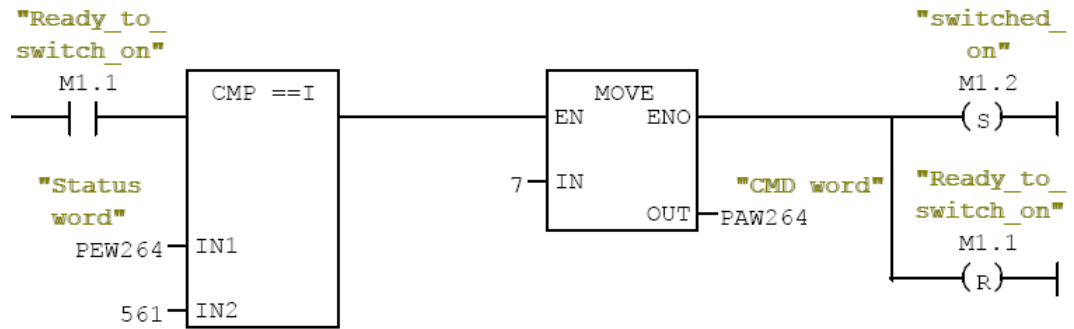

Network: 4

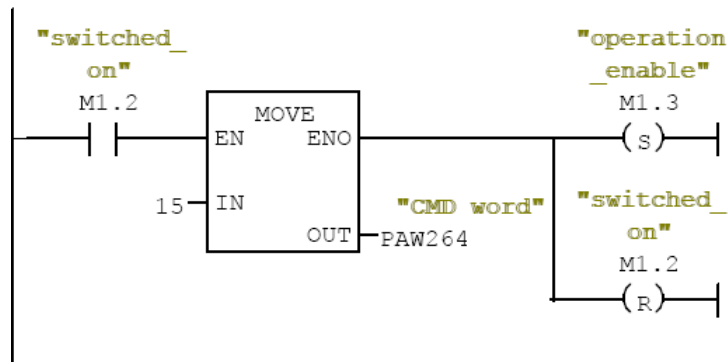

Network: 5

Tempo forward

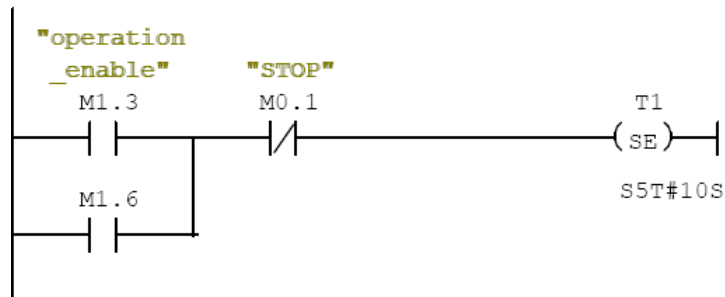

Network: 6

Rising edge Tempo

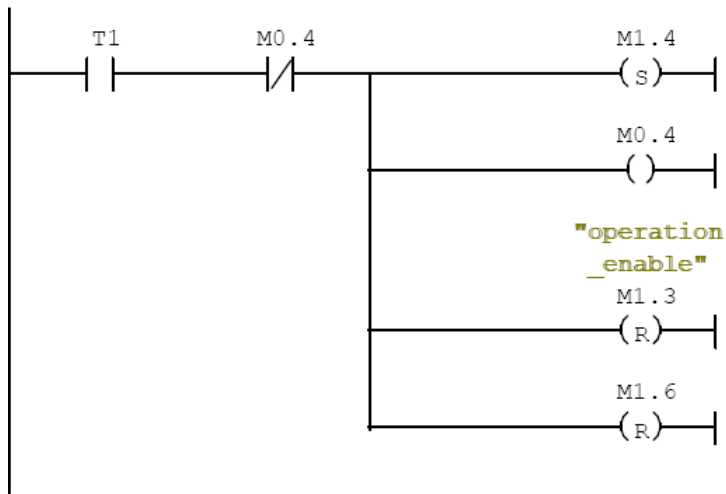

Network: 7

RAMP STOP

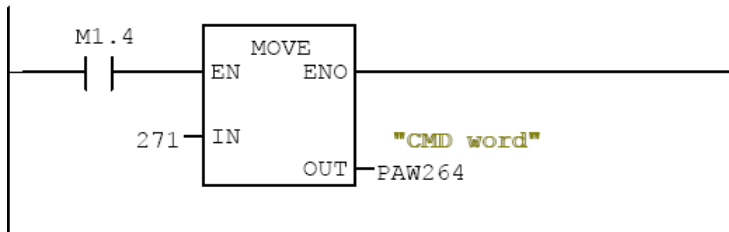

Network: 8

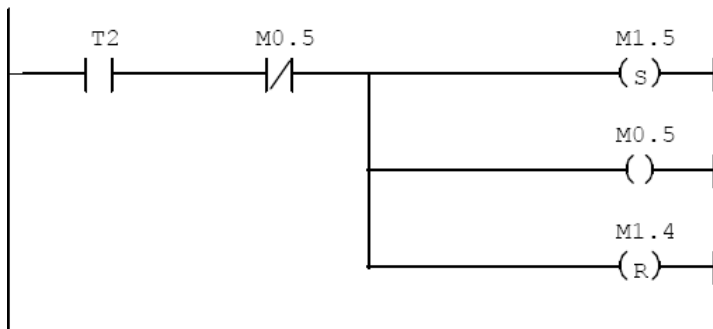

Network: 9

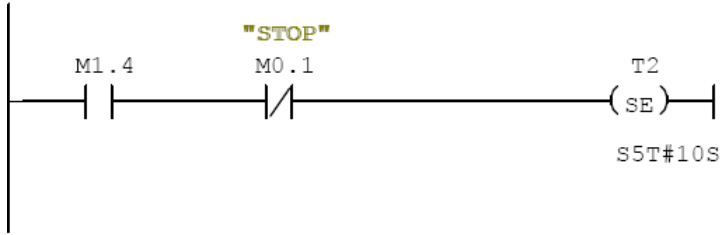

Network: 10

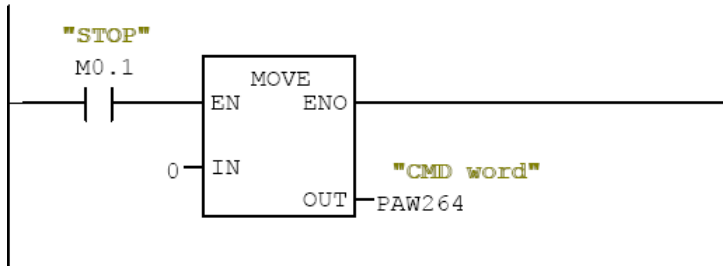

Network: 11

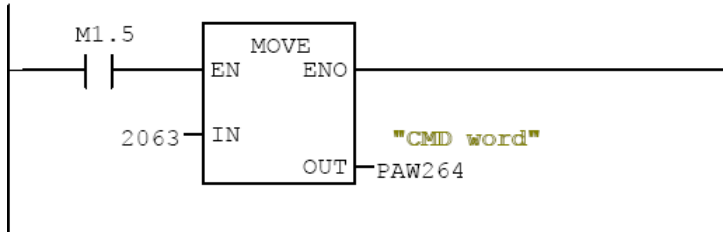

Network: 12

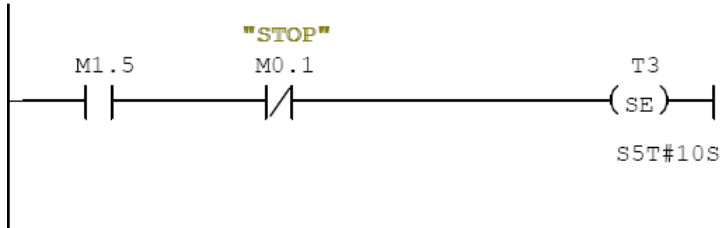

Network: 13

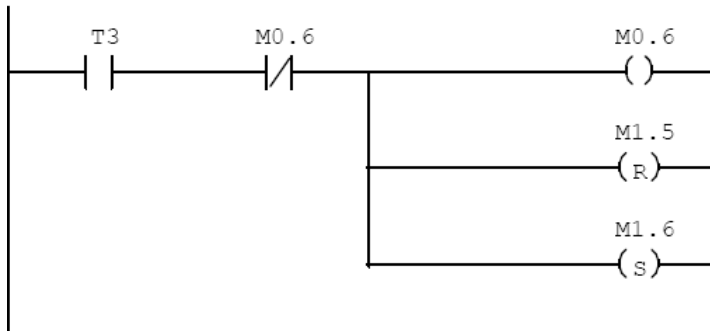

Network: 14

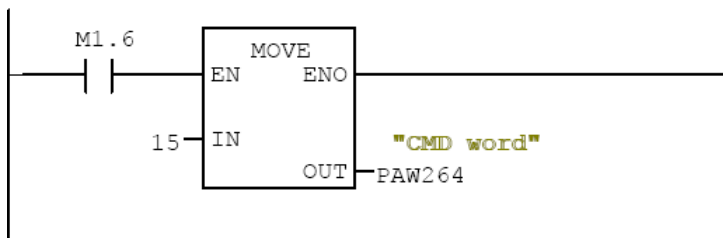

Annex B - The PROFIdrive Parameters Channel

When operated with the PROFIdrive profile, the Altivar 32 parameters are organized as defined by PNU numbering and addressing modes. However, for people who are familiar with the ATV parameters, this addressing mode keeps the native structure of the device (based on Modbus addressing). PNU are numbered from 0 to 65535 and each PNU represents a parameter (from single type as words to complex data structure or arrays). PROFIdrive parameters from PNU 900 to PNU 999 are standardized, they are described hereinafter. All others PNUs are manufacturer specific.

In the case of the Altivar 32, parameters can be separated in two groups:

- Standardized PNUs (900 to 999)
- ATV32 parameters which are gathered in a single PNU entry point: PNU1000.

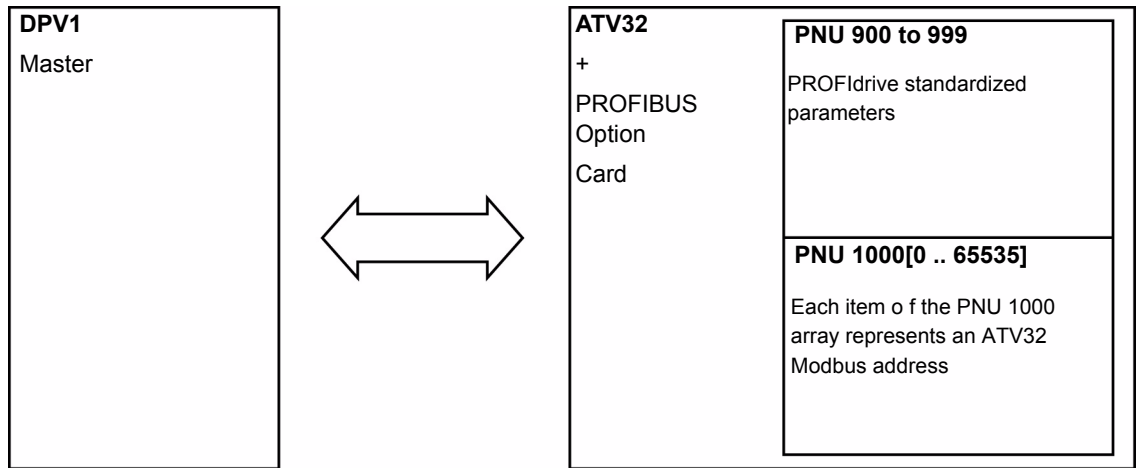

PROFIdrive Based on PROFIBUS DP V1

When the Altivar 32 is operated in PROFIdrive profile, the parameters management takes benefit of the PROFIBUS DP V1 acyclic messaging features: With PROFIBUS DPV1 it is possible to exchange messages of variable length between both master (MS0 or MS1). These messages come in addition of the periodic data exchange.

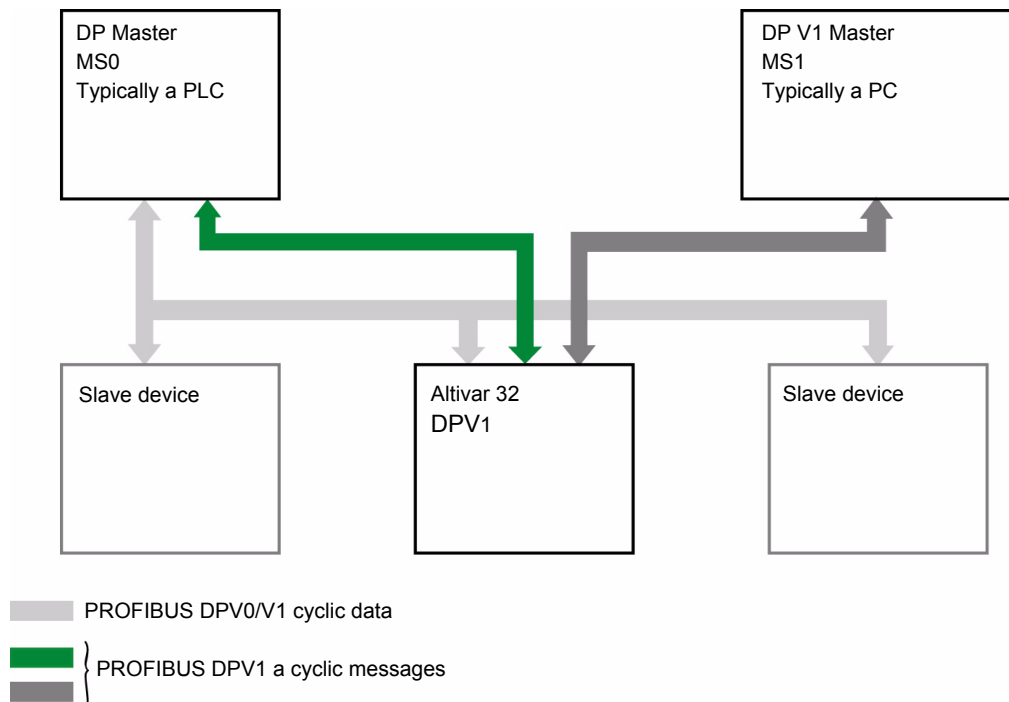

PROFIBUS DP V1 and PROFIdrive Telegrams

The following diagram shows the different encapsulation levels between the PROFIBUS, PROFIBUS DPV1 and PROFIdrive messages:

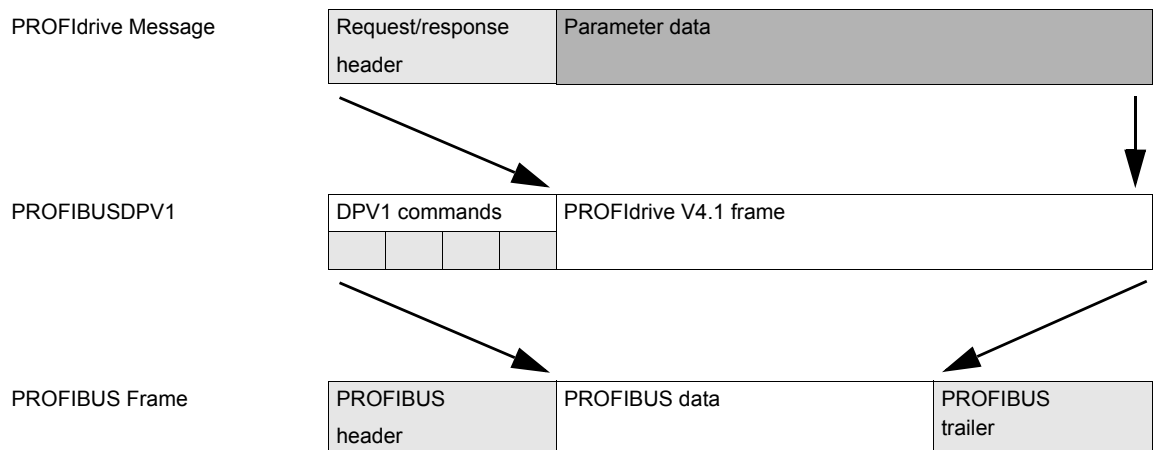

The following table describes the items of the PROFIBUS DP V1 and PROFIdrive messages:

Parameters data	These areas contain the parameter(s) value (a similar request can access multiple parameters in the limits of the DPV1 frame length).
Request / response header	This field consists of the ID of the request, the address and the number of parameters which are accessed.
DPV1 commands	Contains DU bytes 0:DPV1 function, 1:Slot, 2:Index, 3:Data length. (see table below)

PROFIBUS DPV1 Telegram

The following table describes the DPV1 header:

DU	Byte nr	Request
Function code	0	
Slot_num	1	0: global parameters
Index	2	47: Reserved for PROFIdrive
Length	3	Length of PROFIdrive parameter channel frame
Data	4-5	PROFIdrive parameter channel frame: check

PROFIdrive Parameters Structure

A parameter is defined with its PNU number between 1 and 65535.

Each parameter is made of three main areas: **PWE** — the value —, **PBE** — which describes the parameter attributes —, and a text area. The access to the three different areas of a parameter is specified by the "attribute field" of the parameter request. The following diagram summarizes the parameter model (For more information, refer to the Profile drive technology V4 standard).

The parameters and their sub parts are identified as follows:

PNU number + Attribute	16#10	PWE	+ Sub_index
	16#20	PBE	+ Sub_index
	16#30	Text	+ Sub_index

Detail of the PBE Attribute

The following diagram describes the PBE attribute:

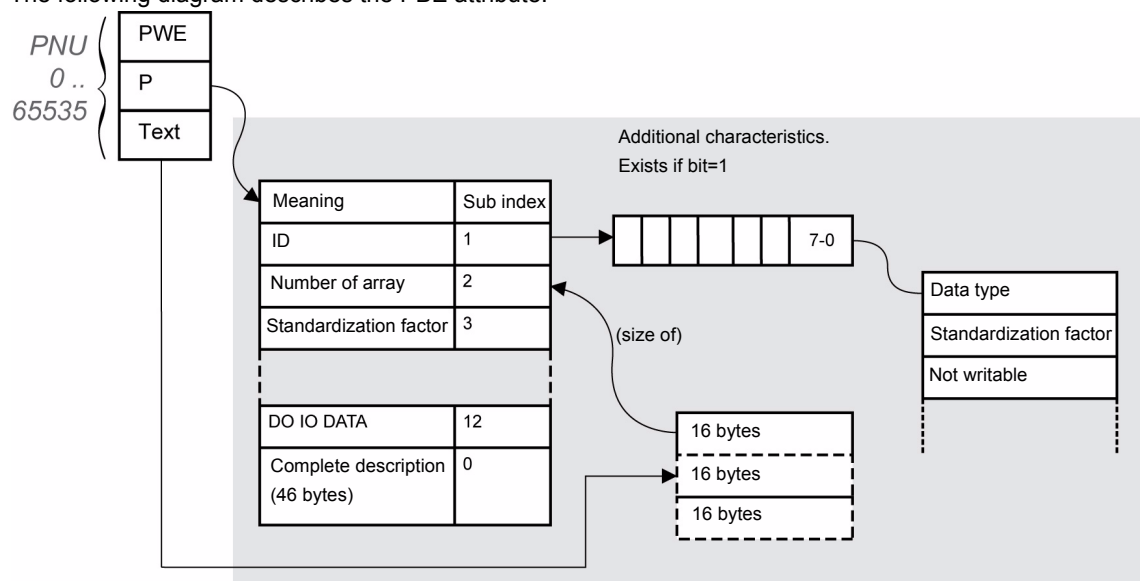

Altivar 32 Parameters

Each Altivar 32 parameter can be represented according to the PNU standard structure. The following table gives the possible values of a parameter according to the PNU properties. All Altivar 32 parameters are part of the PNU 1000. PNU 900 to 999 are described in the “PROFIdrive Standard Parameters” on page 63”.

parameter property	Altivar 32 implementation	Example
PNU number	1000	-
Sub index	Modbus address	[CMD address] (8501)
PWE	Value of the parameter 0...65535	-
PBE	Describes an array of 65535 Words	constant
Text	-	“Altivar 32 parameter”

PROFIdrive Standard Parameters

Parameters 900 to 999 are defined in accordance with the PROFIdrive profile.

The following table describes the required parameters. These parameters are not supported in DPV0 mode.

PNU	Sub ID	Definition	Type	R/W	Comment
900	-	Controller > Altivar 32	-	-	Control telegram. When operated with a MS2 (MS2 has the control of the drive) or the MS1. With the var 32 PNU900, 901 transfer STW1 and ZSW1.
907	-	Controller < Altivar 32	-	-	Status telegram. When operated with a MS2 (MS2 has the control of the drive) or the MS1. With the var 32 PNU900, 901 transfer STW1 and ZSW1.
918	-	Node Address	UINT	R	This parameter contains the PROFIBUS DP address of the Altivar 32. It can also be read from the HMI menu dedicated to the communication module [Address] (AdrC) - Modbus address 6601)
922	-	Telegram selection	UINT	R	This parameter contains the value of the telegram currently in use. Possible values are: <ul style="list-style-type: none"> 1: PROFIdrive. 100,101,102: Native profiles. It can also be read from the HMI menu dedicated to the communication module [PPO profile used] (PrFL) - Modbus address 6665)
927	-	Operation priority	-	-	Enables control
928	-	Control priority	-	-	-
930	-	Operating mode	UINT	-	= 1
944	-	Detected fault message counter	UINT	-	The value of PNU944 is incremented each time a detected fault occurs.
947	-	Detected fault number	UINT	-	If a default has been triggered by the Altivar This parameter contains the detected fault code value. It can also be read from the HMI menu dedicated to the communication module. [Last fault occurred] (LFE) - Modbus address 7121)
964	-	Drive unit identification			
	0	Manufacturer ID	-	-	Defined by PNO
	1	Drive unit	String	-	This UNIT contains the value 32 commercial reference (character string)
	2	Version (drive)	-	-	This parameter contains the Firmware version of the host drive XXyy version, IE
	3	Firmware date (year)	INT	-	Not applicable
	4	Firmware date (day/month)	INT	-	Not applicable
	<i>SubID 5 and 6 are not implemented</i>				
965	-	Profile identification number	UINT	-	Profile identification numbers: Byte 1 = 03: PROFIdrive Byte 2 = 40: V4.01
980 to 989	-	TBD			

Parameters Requests

There are two kinds of requests:

- Request parameter (parameters are PNU number, attribute and Sub_index)
- Change parameter (parameters are PNU number, attribute and Sub_index)

These requests are able to manage one or more parameters or several attributes of one parameter. The number of parameters or parameter elements is restricted by the length of the DPV1 message length (240 bytes). In order to access to a specific attribute of a parameter, the request header contains: the PNU, the sub-ID and an attribute. This attribute defines whether the request mentions the value, the description area or the Text area.

Parameter(s) Reading

- Request:

	Byte n+1	Byte n
	Request reference = 01	Request ID = 01
Request data (1st parameter)	Axis = 16#00	Amount of parameters = 01 to n (n: number of parameter in the request)
	Attribute = 16#10 *	Amount of elements = 1
	PNU number = 1000	
	Sub index = 16#219B (3201) ETA Modbus Address	
Request data (2nd parameter)	Attribute = 16#10 *	Amount of elements = 1
	PNU number = 1000	
	Sub index = Modbus address of the second parameter	

Request data (nth parameter)	Attribute = 16#10 *	Amount of elements = 1
	PNU number = 1000	
	Sub index = Modbus address of the nth second parameter	

*Refers to field "value" (PWE), 16#20 refers to the description field (PBE) and 16#30 to the text field.

- Response (in case of the request contents is made of a single parameter):

	Byte n+1	Byte n
Response Header	Request reference = 01	Request ID = 01
	Axis = 16#00	Amount of parameters = 01
Response data	Format = 16#42 *	Amount of elements = 01
	PNU value = 16#xxxx (value of ETA)	

*Format 16#42 specified that the returned value is a WORD.

Important: The following formats are mandatory:

Byte 16#41, Word 16#42 (or standard integer 16#03), Double word 16#43.

Parameter(s) Writing

- Request:

	Byte n+1	Byte n
Request Header	Request reference = 01	Request ID = 02
	Axis = 16#00	Amount of parameters = 01
Parameter number	Attribute = 16#10 *	Amount of elements = 01
	PNU number = 16#1000	
	Sub index = 16#2329 (9001) ACC Modbus Address	
Parameter value	Format = 16#03 (integer 16)	Amount values = 1
	Value = 50 (ACC is set to 5 s)	

* Refers to field "value", 16#20 refers to the description field and 16#30 to the text field.

This request can also be used for writing multiple parameters.

- Response (if OK):

	Byte n+1	Byte n
Response Header	Request reference = 01	Request ID = 02
	Axis = 16#00	Amount of parameters = 01

Request: Negative Response

The following table lists the items of a negative response:

	Byte n+1	Byte n
Response Header	Request reference = 01	Response ID = 82 *
	Axis = 16#00	Amount of parameters = 01
Parameter number	Format = Error 16#44	Amount of values
Value	Error value 16#xxxx (defined in 3.2.3.4 table28)	

Actually, for all negative responses the ID equals to: response code OR 16#80.

