

Influence of ambient temperature

Influence of temperature on the operation

Devices	Characteristics influenced by temperature	Temperature	
		Min.	Max.
iDPN, C60H-DC, C120, NG125 circuit breakers	Tripping on overload	-30°C	+70°C
iK60 circuit breakers	Tripping on overload	-25°C	+60°C
iC60a/N/H/L circuit breakers	Tripping on overload	-35°C	+70°C
Circuit breakers	With Vigi (AC)	-5°C	+60°C
	With Vigi (A, Asi)	-25°C	+60°C
Reflex iC60	Tripping on overload	-25°C	+60°C
iID K residual current circuit breakers	Maximum operating current	-5°C	+60°C
iID residual current circuit breakers	AC	-5°C	+60°C
	A, Asi	-25°C	+60°C
Switches	iSW	-20°C	+50°C
	iSW-NA	-35°C	+70°C
Protection auxiliaries	None	-35°C	+70°C
RCA, ARA control auxiliaries	None	-25°C	+60°C
iCT contactors	Installation conditions	-5°C	+60°C
iTL impulse relays	None	-20°C	+50°C
iCT, iTL auxiliaries	None	-20°C	+50°C
Distribloc	Maximum operating current	-25°C	+60°C
Multiclip	Maximum operating current	-25°C	+60°C

Note: the temperature considered is the temperature viewed through the device.

iDPN, iK60, iC60, Reflex iC60, C60H-DC, C120, NG125 circuit breakers

High temperatures

- A rise in temperature causes lowering of the thermal threshold (tripping on overload).
 - Protection is still ensured: the tripping threshold remains lower than the current acceptable by the cable (I_z)
 - To prevent nuisance tripping, it should be checked that this threshold remains higher than the maximum operating current (I_B) of the circuit, defined by:
 - the rated load currents,
 - the coefficients of expansion and simultaneity of use.
- If the temperature is sufficiently high for the tripping threshold to become lower than the operating current I_B , switchboard ventilation should be provided for.

Low temperatures

- A fall in temperature increases the thermal tripping threshold of the circuit breaker.
- There is no risk of nuisance tripping: the threshold remains higher than the maximum operating current of the circuit (I_B) demanded by the loads.
- It should be checked that the cable remains suitably protected, i.e. that its acceptable current (I_z) is higher than the values shown in the following tables (in amperes).

When the ambient temperature could vary within a broad range, both these aspects must be taken into account:

- the difference between the maximum operating current of the circuit (I_B) and the tripping threshold of the circuit breaker for the minimum ambient temperature,
- the difference between the strength of the cable (I_z) and the maximum tripping threshold of the circuit breaker for the maximum ambient temperature.

Influence of ambient temperature (cont.)

Maximum permissible current

- The maximum current allowed to flow through the device depends on the ambient temperature in which it is placed.
- The ambient temperature is the temperature inside the enclosure or switchboard in which the devices are installed.
- The reference temperature is in a halftone colour for the different devices.

■ When several devices operating simultaneously are mounted side by side in a small enclosure, a temperature rise in the enclosure results in a reduction in the operating current. A reduction coefficient of 0.8 will then have to be assigned to the rating (already derated, if applicable, depending on the ambient temperature).

■ Example:

Depending on the ambient temperature and the method of installation, the table below shows how to determine, for an iC60, the operating currents not to be exceeded for ratings 25 A, 32 A and 40 A (reference temperature 50°C).

Operating current not to be exceeded (A)							
Installation conditions (IEC 60947-2)		iC60 alone			Several iC60 in the same enclosure (calculate with the reduction coefficient indicated below)		
Ambient temperature (°C)		35°C	50°C	65°C	35°C	50°C	65°C
Type	Nominal rating (A)	Actual rating (A)					
iC60	25	26.35	25	23.57	21.2 x 0.8 = 21	20 x 0.8 = 20	18.7 x 0.8 = 19
	32	34	32	29.90	34 x 0.8 = 27	32 x 0.8 = 25.6	29.9 x 0.8 = 24
	40	42.5	40	37.34	67.7 x 0.8 = 34	63 x 0.8 = 32	57.9 x 0.8 = 30

Influence of ambient temperature (cont.)

Household (IEC 60898-1)

iDPN derating table (IEC 60898-1)

iDPN		Ambient temperature (°C)																				
Rating	Curve	-30	-25	-20	-15	-10	-5	0	+5	+10	+15	+20	+25	+30	+35	+40	+45	+50	+55	+60	+65	+70
1 A	B, C, D	1.55	1.51	1.47	1.43	1.39	1.35	1.30	1.26	1.21	1.16	1.11	1.06	1	0.94	0.88	0.81	0.73	0.65	0.55	0.43	0.27
2 A	B, C, D	2.51	2.47	2.43	2.39	2.35	2.31	2.27	2.23	2.18	2.14	2.09	2.05	2	1.95	1.90	1.85	1.80	1.74	1.69	1.63	1.57
3 A	B, C, D	3.80	3.74	3.68	3.62	3.55	3.49	3.42	3.36	3.29	3.22	3.15	3.07	3	2.92	2.85	2.76	2.68	2.60	2.51	2.42	2.32
4 A	B, C, D	4.97	4.90	4.82	4.75	4.67	4.59	4.51	4.43	4.35	4.26	4.18	4.09	4	3.91	3.81	3.72	3.62	3.52	3.41	3.30	3.19
6 A	B, C, D	7.13	7.04	6.95	6.86	6.77	6.68	6.59	6.49	6.40	6.30	6.20	6.10	6	5.90	5.79	5.68	5.57	5.46	5.35	5.23	5.11
10 A	B	11.88	11.74	11.59	11.44	11.29	11.14	10.98	10.83	10.67	10.50	10.34	10.17	10	9.83	9.65	9.47	9.29	9.10	8.91	8.71	8.52
10 A	C, D	12.31	12.13	11.95	11.77	11.59	11.40	11.21	11.02	10.82	10.62	10.42	10.21	10	9.78	9.56	9.33	9.10	8.86	8.62	8.36	8.10
13 A	B	15.58	15.38	15.18	14.98	14.77	14.56	14.35	14.13	13.91	13.69	13.46	13.23	13	12.76	12.52	12.27	12.02	11.76	11.49	11.22	10.95
13 A	C, D	15.71	15.50	15.29	15.08	14.86	14.64	14.42	14.19	13.96	13.73	13.49	13.25	13	12.75	12.49	12.23	11.96	11.69	11.41	11.12	10.83
16 A	B, C	19.01	18.77	18.54	18.30	18.06	17.81	17.57	17.32	17.06	16.80	16.54	16.27	16	15.72	15.44	15.16	14.86	14.57	14.26	13.95	13.63
16 A	D	19.10	18.86	18.62	18.38	18.13	17.88	17.62	17.36	17.10	16.83	16.56	16.28	16	15.71	15.42	15.13	14.82	14.51	14.20	13.87	13.54
20 A	B	23.66	23.38	23.09	22.80	22.51	22.21	21.91	21.60	21.29	20.98	20.66	20.33	20	19.66	19.32	18.97	18.62	18.26	17.89	17.51	17.13
20 A	C, D	23.89	23.59	23.29	22.98	22.67	22.35	22.03	21.71	21.38	21.04	20.70	20.35	20	19.64	19.28	18.90	18.52	18.13	17.74	17.33	16.92
25 A	B, C, D	29.55	29.20	28.84	28.48	28.12	27.75	27.37	26.99	26.60	26.21	25.81	25.41	25	24.58	24.16	23.73	23.29	22.84	22.38	21.91	21.43
32 A	B, C, D	38.25	37.77	37.28	36.79	36.28	35.78	35.26	34.74	34.21	33.67	33.12	32.57	32	31.42	30.84	30.24	29.63	29.00	28.36	27.71	27.04
40 A	B, C, D	48.30	47.66	47.02	46.36	45.70	45.03	44.34	43.65	42.95	42.23	41.50	40.76	40	39.23	38.44	37.64	36.82	35.98	35.12	34.24	33.34

iK60 derating table, B curve (IEC 60898-1)

iK60		Ambient temperature (°C)																	
Rating		-25	-20	-15	-10	-5	0	+5	+10	+15	+20	+25	+30	+35	+40	+45	+50	+55	+60
1 A		1.19	1.17	1.15	1.14	1.12	1.11	1.09	1.07	1.05	1.04	1.02	1	0.98	0.96	0.94	0.92	0.90	0.88
2 A		2.45	2.41	2.37	2.34	2.30	2.26	2.22	2.17	2.13	2.09	2.04	2	1.95	1.91	1.86	1.81	1.76	1.71
3 A		3.69	3.63	3.57	3.51	3.45	3.39	3.33	3.27	3.20	3.14	3.07	3	2.93	2.86	2.78	2.71	2.63	2.55
4 A		4.92	4.84	4.77	4.69	4.61	4.53	4.44	4.36	4.27	4.18	4.09	4	3.91	3.81	3.71	3.61	3.50	3.39
6 A		7.44	7.32	7.20	7.07	6.95	6.82	6.69	6.56	6.42	6.29	6.14	6	5.85	5.70	5.54	5.38	5.22	5.04
10 A		11.94	11.78	11.61	11.44	11.27	11.10	10.92	10.75	10.56	10.38	10.19	10	9.80	9.61	9.40	9.19	8.98	8.76
16 A		18.97	18.72	18.47	18.21	17.95	17.68	17.41	17.14	16.86	16.58	16.29	16	15.70	15.40	15.09	14.77	14.45	14.11
20 A		23.52	23.22	22.92	22.61	22.30	21.99	21.67	21.35	21.02	20.68	20.35	20	19.65	19.29	18.93	18.55	18.17	17.78
25 A		29.10	28.75	28.40	28.04	27.68	27.31	26.94	26.56	26.18	25.79	25.40	25	24.59	24.18	23.76	23.33	22.90	22.45
32 A		37.87	37.38	36.88	36.37	35.85	35.33	34.79	34.25	33.70	33.15	32.58	32	31.41	30.81	30.20	29.57	28.94	28.28
40 A		47.36	46.74	46.11	45.47	44.82	44.17	43.50	42.82	42.14	41.44	40.72	40	39.26	38.51	37.74	36.96	36.16	35.34
50 A		59.92	59.09	58.24	57.39	56.52	55.63	54.73	53.82	52.89	51.95	50.98	50	49.00	47.97	46.93	45.86	44.76	43.63
63 A		76.37	75.26	74.12	72.97	71.80	70.61	69.40	68.17	66.91	65.64	64.33	63	61.64	60.25	58.83	57.37	55.87	54.33

iK60 derating table, C curve (IEC 60898-1)

iK60		Ambient temperature (°C)																	
Rating		-25	-20	-15	-10	-5	0	+5	+10	+15	+20	+25	+30	+35	+40	+45	+50	+55	+60
1 A		1.20	1.20	1.20	1.10	1.10	1.10	1.10	1.10	1.10	1.00	1.00	1	0.98	0.96	0.94	0.92	0.90	0.88
2 A		2.40	2.40	2.40	2.30	2.30	2.30	2.20	2.20	2.10	2.10	2.00	2	1.95	1.91	1.86	1.81	1.76	1.71
3 A		3.70	3.60	3.60	3.50	3.50	3.40	3.30	3.30	3.20	3.10	3.10	3	2.93	2.86	2.78	2.71	2.63	2.55
4 A		4.90	4.80	4.80	4.70	4.60	4.50	4.40	4.40	4.30	4.20	4.10	4	3.91	3.81	3.71	3.61	3.50	3.39
6 A		7.40	7.30	7.20	7.10	6.90	6.80	6.70	6.60	6.40	6.30	6.10	6	5.85	5.70	5.54	5.38	5.22	5.04
10 A		12.40	12.20	12.00	11.80	11.60	11.40	11.20	10.90	10.70	10.50	10.20	10	9.75	9.49	9.23	8.96	8.68	8.39
16 A		19.40	19.10	18.80	18.50	18.20	17.90	17.60	17.30	17.00	16.70	16.30	16	15.65	15.30	14.94	14.56	14.18	13.79
20 A		24.00	23.60	23.30	23.00	22.60	22.30	21.90	21.50	21.20	20.80	20.40	20	19.60	19.19	18.77	18.34	17.90	17.45
25 A		30.00	29.50	29.10	28.70	28.30	27.80	27.40	26.90	26.40	26.00	25.50	25	24.50	23.99	23.46	22.93	22.38	21.82
32 A		38.80	38.20	37.70	37.10	36.50	35.90	35.30	34.60	34.00	33.30	32.70	32	31.31	30.60	29.87	29.13	28.36	27.57
40 A		47.40	46.70	46.10	45.50	44.80	44.20	43.50	42.80	42.10	41.40	40.70	40	39.26	38.51	37.74	36.96	36.16	35.34
50 A		59.90	59.10	58.20	57.40	56.50	55.60	54.70	53.80	52.90	51.90	51.00	50	49.00	47.97	46.93	45.86	44.76	43.63
63 A		76.40	75.30	74.10	73.00	71.80	70.60	69.40	68.20	66.90	65.60	64.30	63	61.64	60.25	58.83	57.37	55.87	54.33

Influence of ambient temperature (cont.)

Household (IEC 60898-1) (cont.)

iC60 derating table (IEC 60898-1)

iC60	Ambient temperature (°C)																					
Rating	-35	-30	-25	-20	-15	-10	-5	0	+5	+10	+15	+20	+25	+30	+35	+40	+45	+50	+55	+60	+65	+70
0.5 A	0.61	0.60	0.59	0.59	0.58	0.57	0.56	0.55	0.54	0.54	0.53	0.52	0.51	0.5	0.49	0.48	0.47	0.46	0.45	0.44	0.43	0.42
1 A	1.22	1.20	1.19	1.17	1.15	1.14	1.12	1.11	1.09	1.07	1.05	1.04	1.02	1	0.98	0.96	0.94	0.92	0.90	0.88	0.86	0.84
2 A	2.52	2.49	2.45	2.41	2.37	2.34	2.30	2.26	2.22	2.17	2.13	2.09	2.04	2	1.95	1.91	1.86	1.81	1.76	1.71	1.65	1.59
3 A	3.80	3.74	3.69	3.63	3.57	3.51	3.45	3.39	3.33	3.27	3.20	3.14	3.07	3	2.93	2.86	2.78	2.71	2.63	2.55	2.47	2.38
4 A	5.07	5.00	4.92	4.84	4.77	4.69	4.61	4.53	4.44	4.36	4.27	4.18	4.09	4	3.91	3.81	3.71	3.61	3.50	3.39	3.28	3.17
6 A	7.67	7.55	7.44	7.32	7.20	7.07	6.95	6.82	6.69	6.56	6.42	6.29	6.14	6	5.85	5.70	5.54	5.38	5.22	5.04	4.87	4.68
10 A	12.26	12.10	11.94	11.78	11.61	11.44	11.27	11.10	10.92	10.75	10.56	10.38	10.19	10	9.80	9.61	9.40	9.19	8.98	8.76	8.54	8.31
13 A	15.79	15.59	15.39	15.19	14.98	14.78	14.57	14.35	14.14	13.92	13.69	13.47	13.24	13	12.76	12.52	12.27	12.01	11.75	11.49	11.21	10.94
16 A	19.46	19.22	18.97	18.72	18.47	18.21	17.95	17.68	17.41	17.14	16.86	16.58	16.29	16	15.70	15.40	15.09	14.77	14.45	14.11	13.78	13.43
20 A	24.10	23.81	23.52	23.22	22.92	22.61	22.30	21.99	21.67	21.35	21.02	20.68	20.35	20	19.65	19.29	18.93	18.55	18.17	17.78	17.39	16.98
25 A	29.78	29.44	29.10	28.75	28.40	28.04	27.68	27.31	26.94	26.56	26.18	25.79	25.40	25	24.59	24.18	23.76	23.33	22.90	22.45	22.00	21.53
32 A	38.85	38.36	37.87	37.38	36.88	36.37	35.85	35.33	34.79	34.25	33.70	33.15	32.58	32	31.41	30.81	30.20	29.57	28.94	28.28	27.61	26.93
40 A	48.58	47.97	47.36	46.74	46.11	45.47	44.82	44.17	43.50	42.82	42.14	41.44	40.72	40	39.26	38.51	37.74	36.96	36.16	35.34	34.50	33.64
50 A	61.55	60.74	59.92	59.09	58.24	57.39	56.52	55.63	54.73	53.82	52.89	51.95	50.98	50	49.00	47.97	46.93	45.86	44.76	43.63	42.48	41.29
63 A	78.56	77.47	76.37	75.26	74.12	72.97	71.80	70.61	69.40	68.17	66.91	65.64	64.33	63	61.64	60.25	58.83	57.37	55.87	54.33	52.75	51.11

C120 derating table (IEC 60898-1)

C120	Ambient temperature (°C)																				
Rating	-30	-25	-20	-15	-10	-5	0	+5	+10	+15	+20	+25	+30	+35	+40	+45	+50	+55	+60	+65	+70
10 A	12.88	12.66	12.45	12.22	12.00	11.77	11.53	11.29	11.04	10.79	10.53	10.27	10	9.72	9.44	9.14	8.83	8.52	8.19	7.85	7.49
16 A	19.35	19.09	18.83	18.57	18.30	18.03	17.75	17.47	17.19	16.90	16.60	16.31	16	15.69	15.37	15.05	14.72	14.38	14.03	13.67	13.31
20 A	24.59	24.24	23.88	23.52	23.16	22.79	22.41	22.03	21.64	21.24	20.83	20.42	20	19.57	19.13	18.68	18.22	17.74	17.26	16.76	16.24
25 A	30.90	30.46	30.00	29.54	29.07	28.59	28.11	27.61	27.11	26.60	26.08	25.54	25	24.44	23.87	23.29	22.69	22.08	21.45	20.80	20.12
32 A	38.91	38.38	37.85	37.30	36.75	36.19	35.62	35.04	34.46	33.86	33.25	32.63	32	31.36	30.70	30.03	29.34	28.63	27.91	27.17	26.41
40 A	49.82	49.07	48.32	47.55	46.77	45.98	45.17	44.35	43.52	42.67	41.80	40.91	40	39.07	38.12	37.14	36.14	35.11	34.05	32.95	31.82
50 A	62.23	61.30	60.36	59.41	58.44	57.45	56.45	55.42	54.38	53.32	52.24	51.13	50	48.84	47.66	46.44	45.19	43.91	42.59	41.22	39.81
63 A	78.64	77.46	76.26	75.04	73.80	72.53	71.25	69.94	68.61	67.25	65.87	64.45	63	61.52	60.00	58.44	56.84	55.19	53.49	51.74	49.92
80 A	98.41	97.01	95.59	94.15	92.68	91.19	89.68	88.14	86.57	84.98	83.35	81.69	80	78.27	76.50	74.69	72.84	70.93	68.98	66.96	64.89
100 A	124.46	122.61	120.73	118.82	116.87	114.90	112.89	110.85	108.77	106.64	104.47	102.26	100	97.69	95.32	92.89	90.39	87.82	85.18	82.45	79.63
125 A	157.02	154.61	152.16	149.66	147.13	144.55	141.92	139.24	136.51	133.73	130.88	127.98	125	121.95	118.83	115.62	112.31	108.91	105.40	101.77	98.00

Influence of ambient temperature (cont.)

Tertiary/Industry (IEC 60947-2)

DPN derating table (IEC 60947-2)

iDPN		Ambient temperature (°C)																				
Rating	Curve	-30	-25	-20	-15	-10	-5	0	+5	+10	+15	+20	+25	+30	+35	+40	+45	+50	+55	+60	+65	+70
1 A	B, C, D	1.69	1.66	1.62	1.59	1.55	1.51	1.47	1.43	1.39	1.35	1.30	1.26	1.21	1.16	1.11	1.06	1	0.94	0.88	0.81	0.73
2 A	B, C, D	2.68	2.64	2.60	2.56	2.52	2.48	2.44	2.40	2.36	2.32	2.28	2.23	2.19	2.14	2.10	2.05	2	1.95	1.90	1.85	1.79
3 A	B, C, D	4.03	3.97	3.91	3.86	3.80	3.74	3.68	3.61	3.55	3.49	3.42	3.36	3.29	3.22	3.15	3.07	3	2.92	2.85	2.77	2.68
4 A	B, C, D	5.26	5.19	5.12	5.05	4.98	4.90	4.83	4.75	4.67	4.60	4.52	4.43	4.35	4.27	4.18	4.09	4	3.91	3.81	3.72	3.62
6 A	B, C, D	7.51	7.42	7.34	7.25	7.16	7.07	6.98	6.89	6.80	6.70	6.61	6.51	6.41	6.31	6.21	6.11	6	5.89	5.78	5.67	5.56
10 A	B	12.47	12.33	12.19	12.05	11.90	11.76	11.61	11.46	11.30	11.15	10.99	10.83	10.67	10.51	10.34	10.17	10	9.82	9.65	9.46	9.28
10 A	C, D	13.02	12.85	12.68	12.51	12.34	12.16	11.98	11.80	11.61	11.42	11.23	11.03	10.84	10.63	10.43	10.22	10	9.78	9.56	9.32	9.09
13 A	B	16.96	16.74	16.52	16.29	16.06	15.83	15.59	15.35	15.11	14.86	14.61	14.36	14.09	13.83	13.56	13.28	13	12.71	12.42	12.11	11.80
13 A	C, D	17.15	16.92	16.69	16.45	16.21	15.97	15.72	15.47	15.22	14.96	14.69	14.43	14.15	13.87	13.59	13.30	13	12.70	12.38	12.06	11.74
16 A	B, C	20.62	20.36	20.10	19.84	19.57	19.30	19.02	18.74	18.46	18.17	17.87	17.58	17.27	16.96	16.65	16.33	16	15.67	15.32	14.98	14.62
16 A	D	20.78	20.51	20.24	19.97	19.69	19.41	19.13	18.84	18.54	18.24	17.94	17.63	17.32	17.00	16.67	16.34	16	15.65	15.30	14.94	14.56
20 A	B	25.65	25.33	25.01	24.69	24.36	24.03	23.69	23.35	23.00	22.65	22.29	21.92	21.55	21.17	20.79	20.40	20	19.59	19.18	18.75	18.32
20 A	C, D	25.98	25.65	25.31	24.97	24.62	24.27	23.91	23.55	23.18	22.81	22.43	22.04	21.65	21.25	20.84	20.42	20	19.57	19.12	18.67	18.20
25 A	B, C, D	32.02	31.63	31.23	30.83	30.42	30.00	29.58	29.16	28.72	28.29	27.84	27.39	26.93	26.46	25.98	25.50	25	24.49	23.98	23.45	22.91
32 A	B, C, D	41.60	41.06	40.52	39.97	39.42	38.85	38.28	37.70	37.11	36.51	35.90	35.28	34.65	34.01	33.35	32.68	32	31.30	30.59	29.86	29.11
40 A	B, C, D	52.70	51.99	51.28	50.56	49.83	49.08	48.33	47.56	46.78	45.99	45.18	44.36	43.52	42.67	41.80	40.91	40	39.07	38.12	37.14	36.14

iC60, Reflex iC60 derating table (IEC 60947-2)

iC60		Ambient temperature (°C)																					
Rating		-35	-30	-25	-20	-15	-10	-5	0	+5	+10	+15	+20	+25	+30	+35	+40	+45	+50	+55	+60	+65	+70
0.5 A		0.66	0.65	0.64	0.63	0.63	0.62	0.61	0.60	0.59	0.58	0.57	0.56	0.55	0.54	0.53	0.52	0.51	0.5	0.49	0.48	0.47	0.45
1 A		1.32	1.30	1.28	1.27	1.25	1.23	1.21	1.20	1.18	1.16	1.14	1.12	1.10	1.08	1.06	1.04	1.02	1	0.98	0.96	0.93	0.91
2 A		2.79	2.75	2.71	2.67	2.63	2.58	2.54	2.50	2.45	2.40	2.36	2.31	2.26	2.21	2.16	2.11	2.05	2	1.94	1.89	1.83	1.76
3 A		4.21	4.15	4.08	4.02	3.96	3.89	3.83	3.76	3.69	3.62	3.55	3.48	3.40	3.32	3.25	3.17	3.08	3	2.91	2.82	2.73	2.64
4 A		5.62	5.54	5.46	5.37	5.29	5.20	5.11	5.02	4.93	4.83	4.74	4.64	4.54	4.44	4.33	4.22	4.11	4	3.88	3.76	3.64	3.51
6 A		8.55	8.42	8.29	8.16	8.03	7.89	7.75	7.61	7.46	7.31	7.16	7.01	6.85	6.69	6.52	6.35	6.18	6	5.81	5.62	5.43	5.22
10 A		13.34	13.16	12.99	12.81	12.63	12.45	12.26	12.08	11.88	11.69	11.49	11.29	11.09	10.88	10.67	10.45	10.23	10	9.77	9.53	9.29	9.04
13 A		17.09	16.87	16.66	16.44	16.22	15.99	15.77	15.54	15.30	15.06	14.82	14.57	14.32	14.07	13.81	13.55	13.28	13	12.72	12.43	12.14	11.83
16 A		21.09	20.82	20.56	20.28	20.01	19.73	19.45	19.16	18.87	18.57	18.27	17.96	17.65	17.33	17.01	16.68	16.34	16	15.65	15.29	14.92	14.54
20 A		25.99	25.68	25.36	25.04	24.71	24.38	24.05	23.71	23.37	23.02	22.66	22.30	21.94	21.56	21.18	20.80	20.40	20	19.59	19.17	18.74	18.30
25 A		31.91	31.55	31.18	30.81	30.43	30.05	29.66	29.27	28.87	28.46	28.06	27.64	27.22	26.79	26.35	25.91	25.46	25	24.53	24.06	23.57	23.07
32 A		42.04	41.52	40.99	40.45	39.91	39.36	38.80	38.23	37.65	37.07	36.47	35.87	35.25	34.63	33.99	33.34	32.68	32	31.31	30.60	29.88	29.13
40 A		52.59	51.93	51.27	50.59	49.91	49.22	48.52	47.81	47.09	46.35	45.61	44.85	44.08	43.30	42.50	41.68	40.85	40	39.13	38.24	37.34	36.40
50 A		67.14	66.25	65.36	64.45	63.53	62.59	61.64	60.68	59.70	58.70	57.69	56.65	55.60	54.53	53.43	52.31	51.17	50	48.80	47.57	46.31	45.01
63 A		86.28	85.09	83.88	82.65	81.41	80.14	78.86	77.55	76.22	74.87	73.49	72.08	70.65	69.19	67.70	66.17	64.60	63	61.35	59.66	57.92	56.13

Reflex iC60

C60H-DC derating table (IEC 60947-2)

C60H-DC		Ambient temperature (°C)																				
Rating		-30	-25	-20	-15	-10	-5	0	+5	+10	+15	+20	+25	+30	+35	+40	+45	+50	+55	+60	+65	+70
0.5		0.63	0.62	0.61	0.60	0.59	0.58	0.56	0.55	0.54	0.53	0.51	0.5	0.49	0.47	0.46	0.44	0.43	0.41	0.39	0.38	0.36
1		1.18	1.17	1.15	1.14	1.12	1.10	1.09	1.07	1.05	1.04	1.02	1	0.98	0.96	0.94	0.92	0.90	0.88	0.86	0.84	0.82
2		2.54	2.50	2.45	2.41	2.36	2.31	2.26	2.21	2.16	2.11	2.06	2	1.94	1.88	1.82	1.76	1.70	1.63	1.56	1.48	1.41
3		3.78	3.71	3.65	3.58	3.51	3.45	3.38	3.30	3.23	3.16	3.08	3	2.92	2.84	2.75	2.66	2.57	2.48	2.38	2.27	2.17
4		5.08	4.99	4.90	4.81	4.71	4.62	4.52	4.42	4.32	4.22	4.11	4	3.89	3.77	3.65	3.53	3.40	3.27	3.13	2.98	2.83
5		6.00	5.92	5.83	5.74	5.66	5.57	5.48	5.39	5.29	5.20	5.10	5	4.90	4.80	4.69	4.58	4.47	4.36	4.24	4.12	4.00
6		7.26	7.15	7.04	6.94	6.83	6.71	6.60	6.48	6.37	6.25	6.12	6	5.87	5.74	5.61	5.47	5.33	5.19	5.04	4.89	4.73
10		12.59	12.38	12.16	11.94	11.71	11.49	11.25	11.01	10.77	10.52	10.26	10	9.73	9.45	9.17	8.87	8.57	8.25	7.92	7.58	7.22
13		15.49	15.28	15.07	14.85	14.63	14.41	14.19	13.96	13.72	13.49	13.25	13	12.75	12.49	12.23	11.97	11.69	11.41	11.13	10.83	10.53
15		18.61	18.31	18.01	17.70	17.38	17.06	16.74	16.40	16.07	15.72	15.36	15	14.63	14.25	13.85	13.45	13.03	12.60	12.16	11.69	11.21
16		19.43	19.14	18.85	18.55	18.25	17.95	17.64	17.32	17.00	16.68	16.34	16	15.65	15.29	14.93	14.56	14.17	13.78	13.37	12.95	12.52
20		24.06	23.72	23.37	23.02	22.67	22.31	21.94	21.56	21.18	20.80	20.40	20	19.59	19.17	18.74	18.30	17.85	17.39	16.92	16.43	15.93
25		30.35	29.91	29.45	28.99	28.52	28.05	27.56	27.07	26.57	26.06	25.53	25	24.46	23.90	23.33	22.74	22.14	21.53	20.89	20.24	19.56
30		37.35	36.74	36.12	35.50	34.86	34.21	33.54	32.86	32.17	31.46	30.74	30	29.24	28.46	27.66	26.83	25.98	25.10	24.19	23.24	22.25
32		38.45	37.91	37.36	36.80	36.24	35.66	35.08	34.48	33.88	33.27	32.64	32	31.35	30.68	30.00	29.31	28.59	27.86	27.11	26.34	25.54
40		48.92	48.17	47.42	46.65	45.87	45.08	44.28	43.45	42.62	41.76	40.89	40	39.09	38.16	37.20	36.22	35.21	34.17	33.10	31.99	30.84
50		59.93	59.09	58.25	57.39	56.52	55.63	54.74	53.82	52.89	51.95	50.98	50	49.00	47.97	46.93	45.86	44.77	43.64	42.49	41.31	40.09
63		78.16	76.91	75.63	74.33	73.01	71.67	70.30	68.90	67.47	66.02	64.53	63	61.44	59.83	58.18	56.49	54.74	52.93	51.06	49.12	47.10

Influence of ambient temperature (cont.)

Tertiary/Industry (IEC 60947-2) (cont.)

C120 derating table (IEC 60947-2)

C120	Ambient temperature (°C)																				
Rating	-30	-25	-20	-15	-10	-5	0	+5	+10	+15	+20	+25	+30	+35	+40	+45	+50	+55	+60	+65	+70
10 A	14.49	14.25	14.01	13.76	13.51	13.25	12.99	12.72	12.45	12.17	11.89	11.59	11.29	10.98	10.67	10.34	10	9.65	9.29	8.91	8.51
16 A	21.24	20.95	20.66	20.36	20.06	19.76	19.44	19.13	18.81	18.48	18.15	17.81	17.46	17.11	16.75	16.38	16	15.61	15.22	14.81	14.39
20 A	27.03	26.64	26.25	25.85	25.45	25.04	24.63	24.20	23.77	23.34	22.89	22.43	21.97	21.49	21.01	20.51	20	19.48	18.94	18.39	17.82
25 A	33.73	33.25	32.76	32.27	31.77	31.26	30.75	30.22	29.69	29.14	28.59	28.02	27.45	26.86	26.25	25.63	25	24.35	23.68	22.99	22.28
32 A	42.70	42.11	41.52	40.91	40.29	39.67	39.03	38.39	37.73	37.06	36.38	35.69	34.98	34.26	33.53	32.77	32	31.21	30.40	29.56	28.71
40 A	54.80	54.00	53.18	52.35	51.50	50.65	49.77	48.88	47.98	47.05	46.11	45.15	44.17	43.17	42.14	41.08	40	38.89	37.74	36.56	35.34
50 A	69.08	68.05	67.00	65.93	64.84	63.74	62.62	61.47	60.30	59.12	57.90	56.66	55.39	54.10	52.77	51.40	50	48.56	47.07	45.53	43.94
63 A	87.12	85.81	84.48	83.13	81.76	80.36	78.94	77.50	76.02	74.52	72.98	71.42	69.82	68.18	66.50	64.77	63	61.18	59.30	57.36	55.35
80 A	103.67	102.35	101.01	99.66	98.29	96.90	95.48	94.05	92.59	91.12	89.61	88.08	86.53	84.94	83.33	81.68	80	78.28	76.53	74.73	72.89
100 A	137.58	135.54	133.47	131.37	129.23	127.05	124.84	122.59	120.29	117.95	115.56	113.12	110.62	108.07	105.45	102.76	100	97.16	94.22	91.19	88.05
125 A	174.56	171.88	169.16	166.40	163.59	160.73	157.82	154.85	151.82	148.74	145.59	142.36	139.06	135.69	132.22	128.66	125	121.23	117.33	113.30	109.12

NG125 derating table (IEC 60947-2)

NG125	Ambient temperature (°C)																				
Rating	-30	-25	-20	-15	-10	-5	0	+5	+10	+15	+20	+25	+30	+35	+40	+45	+50	+55	+60	+65	+70
10 A	13.70	13.47	13.24	13.00	12.75	12.51	12.25	11.99	11.73	11.46	11.18	10.90	10.61	10.31	10	9.68	9.35	9.01	8.66	8.29	7.90
16 A	20.32	20.05	19.76	19.48	19.19	18.89	18.59	18.29	17.98	17.67	17.35	17.02	16.69	16.35	16	15.65	15.28	14.91	14.53	14.14	13.74
20 A	26.02	25.64	25.25	24.85	24.45	24.04	23.63	23.21	22.77	22.34	21.89	21.43	20.97	20.49	20	19.50	18.99	18.46	17.91	17.35	16.77
25 A	33.76	33.21	32.65	32.08	31.51	30.92	30.32	29.70	29.08	28.44	27.79	27.12	26.43	25.72	25	24.25	23.48	22.69	21.86	21.00	20.11
32 A	41.19	40.60	40.00	39.40	38.79	38.16	37.53	36.88	36.22	35.55	34.87	34.18	33.47	32.74	32	31.24	30.46	29.66	28.84	28.00	27.13
40 A	53.54	52.69	51.83	50.95	50.05	49.14	48.21	47.26	46.29	45.30	44.29	43.26	42.20	41.12	40	38.85	37.67	36.45	35.19	33.87	32.51
50 A	66.26	65.23	64.19	63.13	62.05	60.95	59.83	58.69	57.53	56.35	55.14	53.90	52.63	51.33	50	48.63	47.22	45.77	44.27	42.72	41.11
63 A	83.42	82.13	80.82	79.49	78.14	76.76	75.35	73.92	72.46	70.97	69.45	67.90	66.30	64.67	63	61.28	59.51	57.69	55.81	53.86	51.84
80 A	100.41	99.09	97.75	96.40	95.02	93.63	92.21	90.78	89.32	87.83	86.32	84.79	83.22	81.63	80	78.34	76.64	74.91	73.13	71.31	69.44
100 A	133.37	131.26	129.13	126.96	124.75	122.50	120.21	117.87	115.49	113.05	110.57	108.02	105.42	102.74	100	97.18	94.27	91.28	88.18	84.97	81.63
125 A	165.22	162.68	160.09	157.47	154.80	152.08	149.32	146.50	143.62	140.69	137.70	134.63	131.50	128.29	125	121.62	118.14	114.56	110.86	107.03	103.06

Influence of ambient temperature (cont.)

Switches

■ In all cases, the switches are correctly protected against overloads by a circuit breaker with a lower or equal rating, operating at the same ambient temperature.

iCT contactors

In the case of contactor mounting in an enclosure for which the interior temperature is in a range between 50°C and 60°C, it is necessary to use a spacer, cat. no. A9A27062, between each contactor.

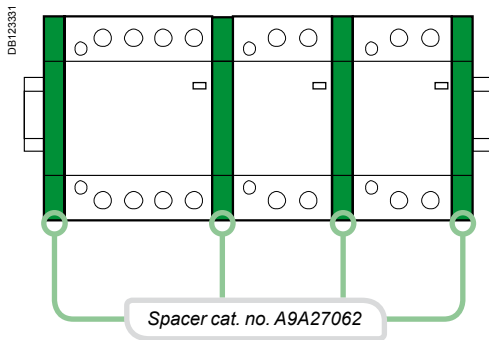

Splitter blocks

In the event of a temperature higher than 40°C, the maximum acceptable current is limited to the values in the table below:

Type	Temperature				
	40°C	45°C	50°C	55°C	60°C
Multiclip 80 A	80	76	73	69	66
Distribloc 63 A	63	60	58	55	53

