

# Altivar 61/71

## EtherNet/IP™ card

### User manual

VW3A3320

02/2013

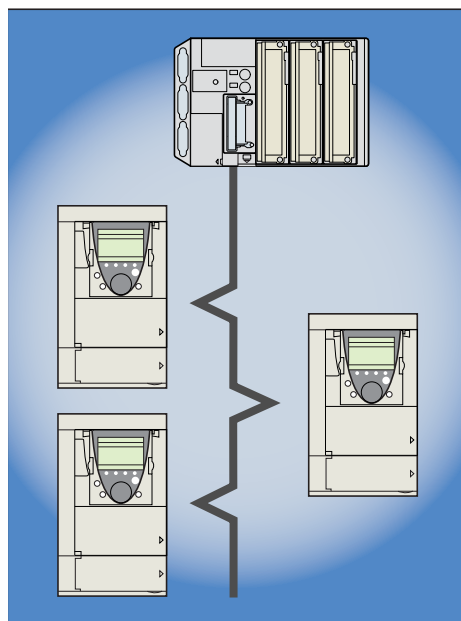

The information provided in this documentation contains general descriptions and/or technical characteristics of the performance of the products contained herein. This documentation is not intended as a substitute for and is not to be used for determining suitability or reliability of these products for specific user applications. It is the duty of any such user or integrator to perform the appropriate and complete risk analysis, evaluation and testing of the products with respect to the relevant specific application or use thereof. Neither Schneider Electric nor any of its affiliates or subsidiaries shall be responsible or liable for misuse of the information contained herein. If you have any suggestions for improvements or amendments or have found errors in this publication, please notify us.

No part of this document may be reproduced in any form or by any means, electronic or mechanical, including photocopying, without express written permission of Schneider Electric.

All pertinent state, regional, and local safety regulations must be observed when installing and using this product. For reasons of safety and to help ensure compliance with documented system data, only the manufacturer should perform repairs to components.

When devices are used for applications with technical safety requirements, the relevant instructions must be followed.

Failure to use Schneider Electric software or approved software with our hardware products may result in injury, harm, or improper operating results.

Failure to observe this information can result in injury or equipment damage.

© 2012 Schneider Electric. All rights reserved.

# Table of contents

---

Table of contents	3
Important Information	4
About the book	5
Before you begin	6
Documentation structure	7
Introduction	8
Presentation	8
Notation	8
Hardware setup	9
Receipt	9
Hardware description	9
Installing the card in the drive. See the Installation Manual (1760643 or 1760655).	10
Connecting to the EtherNet/IP network	11
Card RJ45 connector pinout	11
Example of connection to an EtherNet/IP network	11
Ethernet menu	13
Access to EtherNet menu via graphic display terminal	13
Access to EtherNet menu via the integrated display terminal	13
Ethernet/IP configuration with the HMI	14
Detail of the configured parameters	16
Assemblies and scanner configuration	16
Configuration of the assemblies	17
Configuration of the assemblies: overview	17
Configuration of the assembly (100,101) Schneider-Electric native profile	18
Configuration of the assembly (103,104) Allen Bradley® profile	19
Configuring the communication scanner	20
Configuring the control	21
Fault management	26
Fault management	26
Status of the LEDs	27
Configuration of monitored parameters	28
Standard Web server	29
Webserver function	29
Applets	30
Access to the Web server	31
Web server user interface	32
"Home" menu	32
"Monitoring" menu	32
Diagnostics	36
"Setup" menu	39
"Security" Submenu	45
"Documentation" menu	46
Integration in RSLogix	47
Principle	47
Procedure	47
Registering the EDS file in RSlogix	54
CIP objects	57
Supported object classes	57
Identity object	57
Message router object	61
Ethernet Link object	63
TCP/IP Interface object	66
Connection object manager	68
Motor data object	69
Control supervisor object	70
AC/DC Drive Object	72
Assembly object	73
Application objects	74
Explicit Messaging	76
Device profiles	77

# 1. Important Information

---

## NOTICE

Read these instructions carefully, and look at the equipment to become familiar with the device before trying to install, operate, or maintain it. The following special messages may appear throughout this documentation or on the equipment to warn of potential hazards or to call attention to information that clarifies or simplifies a procedure.



The addition of this symbol to a Danger or Warning safety label indicates that an electrical hazard exists, which will result in personal injury if the instructions are not followed.



This is the safety alert symbol. It is used to alert you to potential personal injury hazards. Obey all safety messages that follow this symbol to avoid possible injury or death.

## **DANGER**

**DANGER** indicates an imminently hazardous situation, which, if not avoided, **will result** in death or serious injury.

## **WARNING**

**WARNING** indicates a potentially hazardous situation, which, if not avoided, **can result** in death, serious injury or equipment damage.

## **CAUTION**

**CAUTION** indicates a potentially hazardous situation, which, if not avoided, **can result** in injury or equipment damage.

## **NOTICE**

**NOTICE** is used to address practices not related to physical injury.

## PLEASE NOTE

The word "drive" as used in this manual refers to the controller portion of the adjustable speed drive as defined by NEC.

Electrical equipment should be installed, operated, serviced, and maintained only by qualified personnel. No responsibility is assumed by Schneider Electric for any consequences arising out of the use of this product.

© 2012 Schneider Electric. All Rights Reserved.

## 2. About the book

---

### Document Scope

The purpose of this document is to:

- show you how to install the EtherNet/IP card module on your Altivar 61 / 71,
- show you how to configure the Altivar 61 / 71 to use EtherNet/IP fieldbus.

**NOTE:** Read and understand this document and all related documents (see below) before installing, operating, or maintaining your ATV61 / 71.

### Validity Note

This documentation is valid for the Altivar 61 / 71 EtherNet fieldbus.

### Related Documents

Title of Documentation	Reference Number
ATV61 Quick Start guide	S1B86974
ATV71 Quick Start guide	S1B86982
ATV61 > 75kW Installation manual	1760655
ATV71 > 75kW Installation manual	1755849
ATV61 0,37kW to 75 kW Installation manual	1760643
ATV71 0,37kW to 75 kW Installation manual	1755843
ATV61 Programming manual	1760649
ATV71 Programming manual	1755855
ATV71 S383 Programming manual	AAV49426
ATV71 Communication Parameters manual	1755861
ATV61 Communication parameters manual	1760661
ATV71 Integrated Modbus manual	1755863
ATV71 Modbus Plus manual	1755869
ATV71 Uni-Telway manual	1755867
ATV71 Modbus with Uni-Telway manual	1755875
ATV61/71 CC-Link manual	AAV49429
ATV61/71 Standard Fipio manual	1755883
ATV61 LonWorks card manual	1765273
ATV61 BACnet manual	1765274
ATV61/71 DeviceNet manual	1755877
ATV61 Metasys N2 manual	AAV33578
ATV61 APOGEE FLN P1 manual	BBV10543
ATV61/71 INTERBUS manual	1755871
ATV61/71 Profibus DP manual	1755873
ATV61/71 Profibus DPv1 manual	AAV52935
ATV61/71 Controller Inside manual	1757062
ATV61/71 CANopen manual	1755865
ATV61/71 EtherNet-IP manual	AAV68822
ATV61/71 Ethernet - Modbus TCP-IP manual	1755879
ATV61/71 Modbus TCP-IP manual - Daisy Chain Ethernet card manual	AAV69931
ATV61/71 ModbusTCP manual_VW3A3320	HRB10064
ATV61/71 EthernetIP manual VW3A3320	HRB10065
ATV61/71 LIFT Safety integrated function manual	S1A91443
ATV61/71 certificates, see <a href="http://www.schneider-electric.com">www.schneider-electric.com</a>	

You can download the latest versions of these technical publications and other technical information from [www.schneider-electric.com](http://www.schneider-electric.com).

### 3. Before you begin

#### **⚠ DANGER**

##### **UNINTENDED EQUIPMENT OPERATION**

- Read and understand this manual before installing or operating the drive.
- Any changes made to the parameter settings must be performed by qualified personnel.

**Failure to follow these instructions will result in death or serious injury.**

#### **⚠⚠ DANGER**

##### **HAZARD OF ELECTRIC SHOCK, EXPLOSION OR ARC FLASH**

- Only appropriately trained persons who are familiar with and understand the contents of this manual and all other pertinent product documentation and who have received safety training to recognize and avoid hazards involved are authorized to work on and with this product system. Installation, adjustment, repair and maintenance must be performed by qualified personnel.
- The system integrator is responsible for compliance with all local and national electrical code requirements as well as all other applicable regulations with respect to grounding of all equipment.
- Many components of the product, including the printed circuit boards, operate with mains voltage. Do not touch. Use only electrically insulated tools.
- Do not touch unshielded components or terminals with voltage present.
- Motors can generate voltage when the shaft is rotated. Prior to performing any type of work on the product system, block the motor shaft to prevent rotation.
- AC voltage can couple voltage to unused conductors in the motor cable. Insulate both ends of unused conductors of the motor cable.
- Do not short across the DC bus terminals or the DC bus capacitors or the braking resistor terminals.
- Before performing work on the product system:
  - Disconnect all power, including external control power that may be present.
  - Place a "Do Not Turn On" label on all power switches.
  - Lock all power switches in the open position.
  - Wait 15 minutes to allow the DC bus capacitors to discharge. The DC bus LED is not an indicator of the absence of DC bus voltage that can exceed 800 Vdc.  
Measure the voltage on the DC bus between the DC bus terminals using a properly rated voltmeter to verify that the voltage is <42 Vdc.
  - If the DC bus capacitors do not discharge properly, contact your local Schneider Electric representative.
- Install and close all covers before applying voltage.

**Failure to follow these instructions will result in death or serious injury.**

#### **⚠ WARNING**

##### **DAMAGE DRIVE EQUIPMENT**

Do not operate or install any drive or drive accessory that appears damaged.

**Failure to follow these instructions can result in death, serious injury, or equipment damage.**

#### **⚠ WARNING**

##### **LOSS OF CONTROL**

- The designer of any wiring scheme must consider the potential failure modes of control channels and, for certain critical control functions, provide a means to achieve a safe state during and after a channel failure. Examples of critical control functions are emergency stop and overtravel stop.
- Separate or redundant control paths must be provided for critical control functions.
- System control channels may include links carried out by the communication. Consideration must be given to the implications of unanticipated transmission delays or failures of the link.(1)

**Failure to follow these instructions can result in death, serious injury, or equipment damage.**

(1) For additional information, refer to NEMA ICS 1.1 (latest edition), "Safety Guidelines for the Application, Installation, and Maintenance of Solid State Control" and to NEMA ICS 7.1 (latest edition), "Safety Standards for Construction and Guide for Selection, Installation and Operation of Adjustable-Speed Drive Systems."

## 4. Documentation structure

---

The following Altivar 61/71 technical documents are available on the Web site [www.schneider-electric.com](http://www.schneider-electric.com).

### ■ Installation Manual

This manual describes:

- How to assemble the drive.
- How to connect the drive.

### ■ Programming Manual

This manual describes:

- The functions.
- The parameters.
- How to use the drive display terminal (integrated display terminal and graphic display terminal).

### ■ Communication Parameters Manual

This manual describes:

- The drive parameters with specific information (addresses, formats, etc.) for use via a bus or communication network.
- The operating modes specific to communication (state chart).
- The interaction between communication and local control.

### ■ Modbus<sup>®</sup>, CANopen<sup>®</sup>, EtherNet<sup>™</sup>, Profibus, INTERBUS, Uni-Telway, DeviceNet<sup>™</sup>, Modbus<sup>®</sup> Plus, etc., manuals.

These manuals describe:

- Connection to the bus or network.
- Configuration of the communication-specific parameters via the integrated display terminal or the graphic display terminal.
- Diagnostics.
- Software setup.
- The communication services specific to the protocol.

### ■ Altivar 58/58F Migration Manual

This manual describes the differences between the Altivar 71 and the Altivar 58/58F.

It explains how to replace an Altivar 58 or 58F, including how to replace drives communicating on a bus or network.

# 5. Introduction

---

## 5. 1. Presentation

The EtherNet/IP card (catalog number VW3 A3320) is used to connect an Altivar 61/71 drive to an Ethernet network using the EtherNet/IP protocol.

This communication option card is fully supported with the version V5.7 and above of the Altivar 61 firmware and with the version V5.8 and above of Altivar 71 firmware.

The VW3 A3320 card is equipped with two shielded RJ45 EtherNet connectors.

The accessories for connection to the EtherNet/IP network must be ordered separately.

The data exchanges permit full drive functionality:

- Configuration
- Adjustment
- Control
- Monitoring
- Diagnostics

The standard Web server (English only) provides access to the following pages:

- Monitoring
- Diagnostics
- Setup
- RSTP management

The standard Web server can be adapted or replaced by a customized server depending on the requirements of the application.

The graphic display terminal or the integrated display terminal can be used to access numerous functions for communication diagnostics.

## 5. 2. Notation

### Drive terminal displays

The graphic display terminal menus are shown in square brackets.

Example: [1.9 COMMUNICATION].

The integrated 7-segment display terminal menus are shown in round brackets.

Example: (C D P -).

The parameter names displayed on the graphic display terminal are shown in square brackets.

Example: [Fallback speed].

The parameter codes displayed on the integrated 7-segment display terminal are shown in round brackets.

Example: (L F F).

### Formats

Hexadecimal values are written as follows: 16#

Binary values are written as follows: 2#

PC-Software: Commissioning Software

## 6. Hardware setup

### 6. 1. Receipt

- Check that the card catalog number marked on the label is the same as that on the delivery note corresponding to the purchase order.
- Remove the option card from its packaging and check that it has not been damaged in transit.

## **⚠ CAUTION**

### **STATIC SENSITIVE COMPONENTS**

The EtherNet/IP card can be damaged by static electricity. Observe electrostatic precautions when handling and installing the card.

**Failure to follow this instruction can result in equipment damage.**

### 6. 2. Hardware description

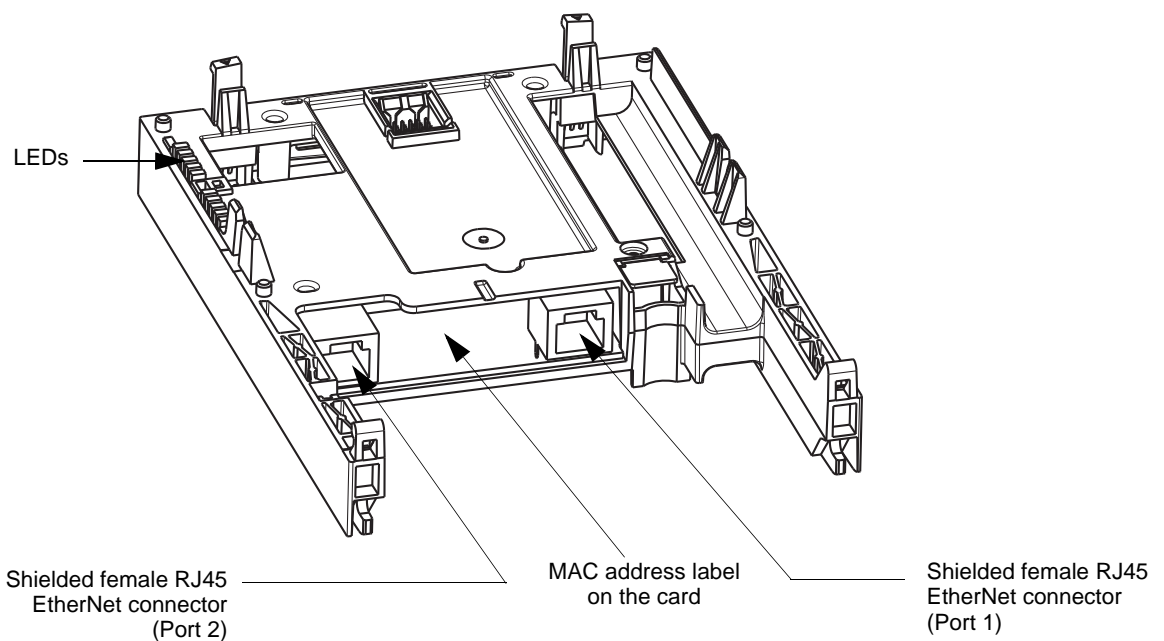

## 6. Hardware setup

### 6. 3. Installing the card in the drive. See the Installation Manual (1760643 or 1760655).

#### ■ Removing the control front panel

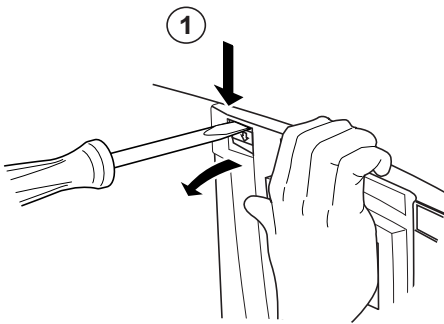

- Using a screwdriver, press down on the catch and pull to release the left-hand part of the control front panel

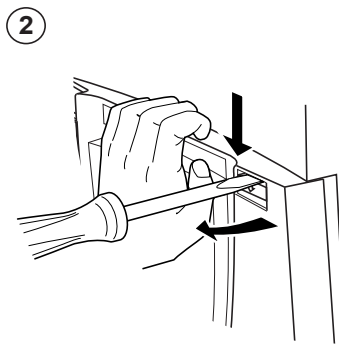

- Do the same on the right-hand side

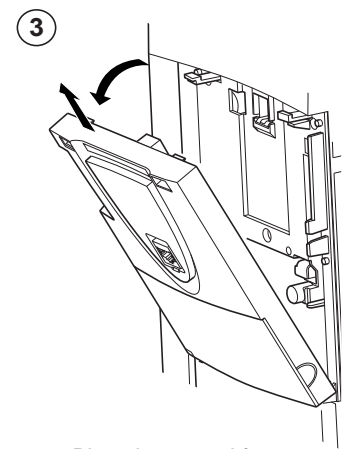

- Pivot the control front panel and remove it

#### ■ Installing an I/O extension card, a communication card or a “Controller Inside” programmable card

### CAUTION

#### RISK OF DAMAGE TO THE CONNECTOR

Ensure good positioning of the option card on the clasps to avoid damage to the connector.

Failure to follow these instructions can result in equipment damage.

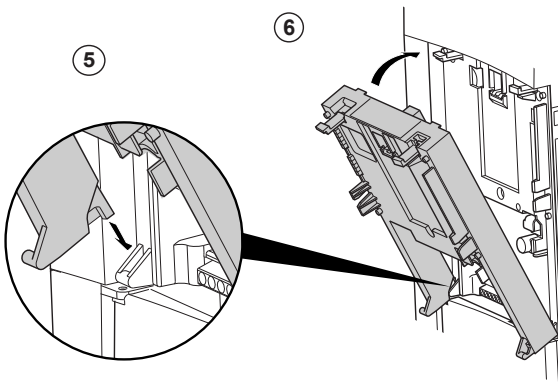

- ①, ② and ③ Remove the control front panel (see previous page)

- ④ Install an encoder interface card (if used) (see previous page)

- ⑤ Position the option card on the clasps

- ⑥ Then pivot it until it clicks into place

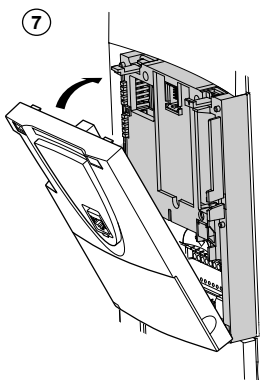

- ⑦ Replace the control front panel over the option card (same procedure as for installing the option card, see ⑤ and ⑥)

# 7. Connecting to the EtherNet/IP network

## 7. 1. Card RJ45 connector pinout

The EtherNet/IP card is equipped with two shielded RJ45 connectors. The shielding is connected to the drive ground. The dielectric isolation is 1500Vrms.

Use an STP (shielded twisted pair) EtherNet/IP cable.

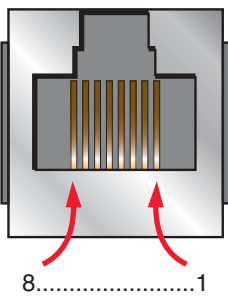

Pin	Signal
1	TD+
2	TD-
3	RD+
4	
5	
6	RD-
7	
8	

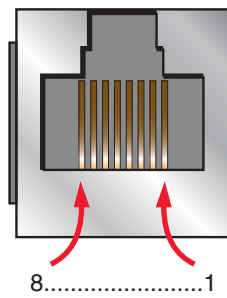

The transmission speed is detected automatically by the card (10 Mbps or 100 Mbps).

The card can operate in half duplex or full duplex mode, whether connected to a hub or a switch and regardless of the transmission speed (10 Mbps or 100 Mbps). Devices of the network shall be all set to the same baudrate manually or all set to automatic baudrate detection.

**Note:** RSTP function is not compatible with half duplex configuration. All devices involved in the RSTP topology shall be RSTP capable and configured.

## 7. 2. Example of connection to an EtherNet/IP network

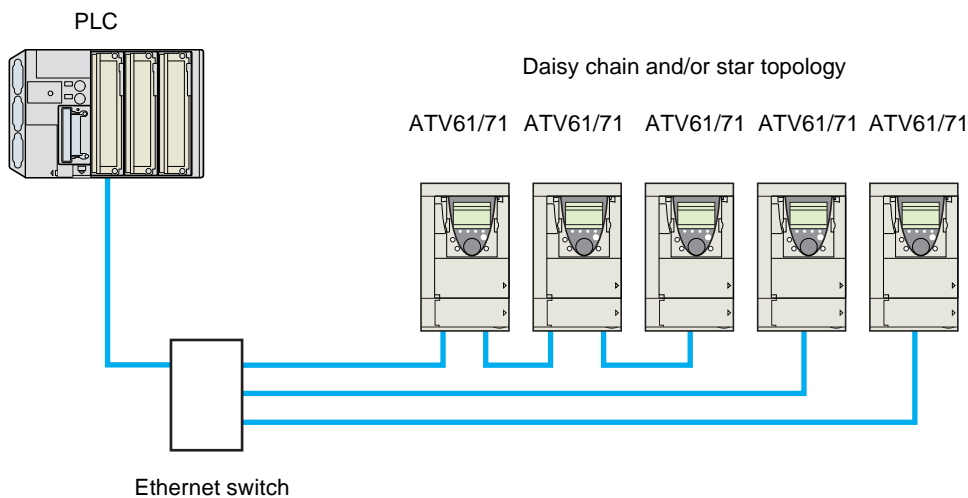

**Note:** When the topology is a daisy chain, if one drive is turned off, the drive(s) next the drive powered off trip in CNF. To keep the integrity of the Ethernet daisy chain network even if one or several drives are powered off, it is mandatory to add an external permanent 24VDC supply for the drives control bloc.

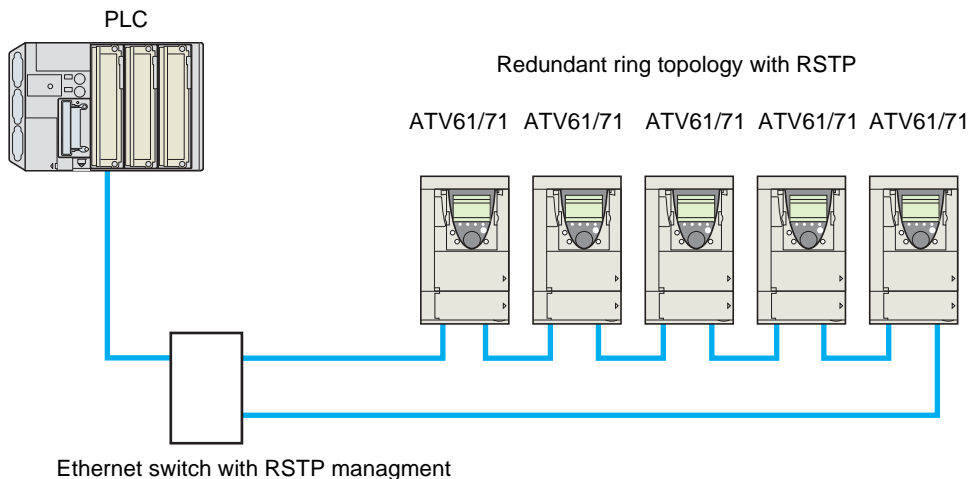

## 6. Connecting to the EtherNet/IP network

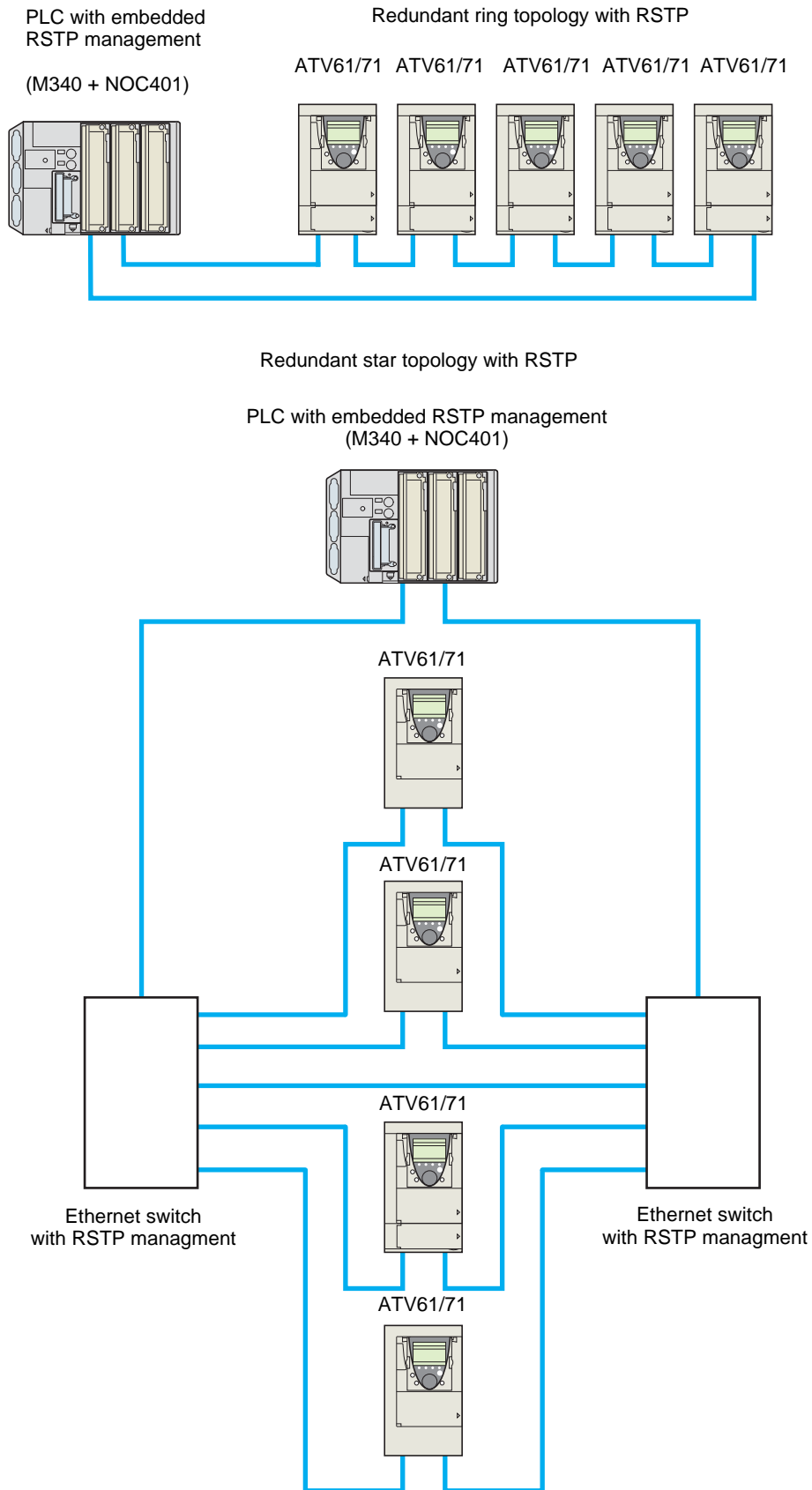

## 8. Ethernet menu

### 8. 1. Access to EtherNet menu via graphic display terminal

The [ETHERNET RSTP] (*E t H r 5*) submenu is used to configure and display the EtherNet/IP card parameters and can be accessed via the [1.9 COMMUNICATION] menu.

This menu is only accessible in standard, advanced and expert mode: In the [2 ACCESS LEVEL] (*L A C -*) menu, set the level to [expert] (*E P r*).

Can be accessed by the other level.

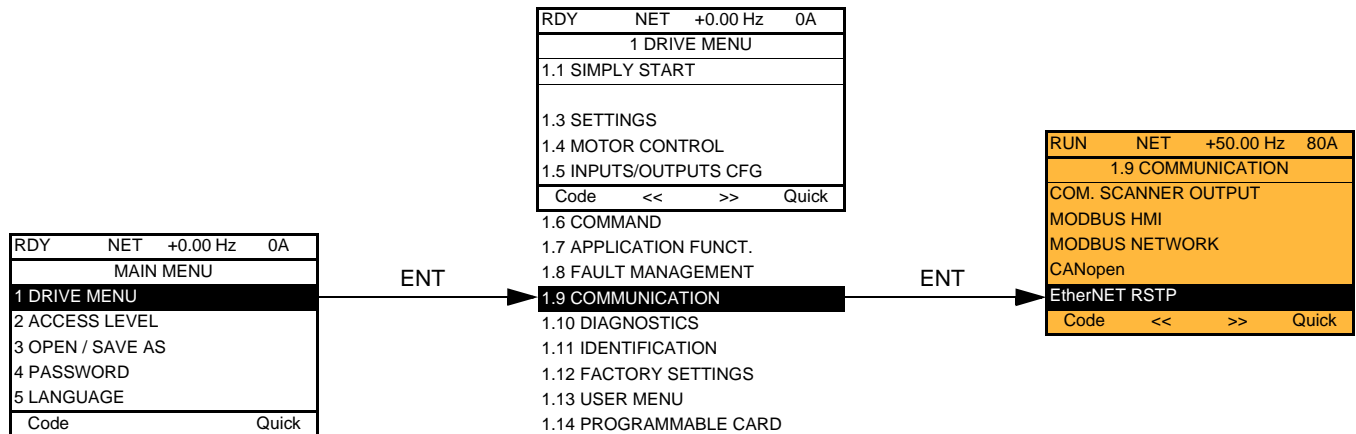

### 8. 2. Access to EtherNet menu via the integrated display terminal

The (*E t H -*) submenu is used to configure and display the EtherNet/IP card parameters. It can be accessed via the (*C O N -*) menu.

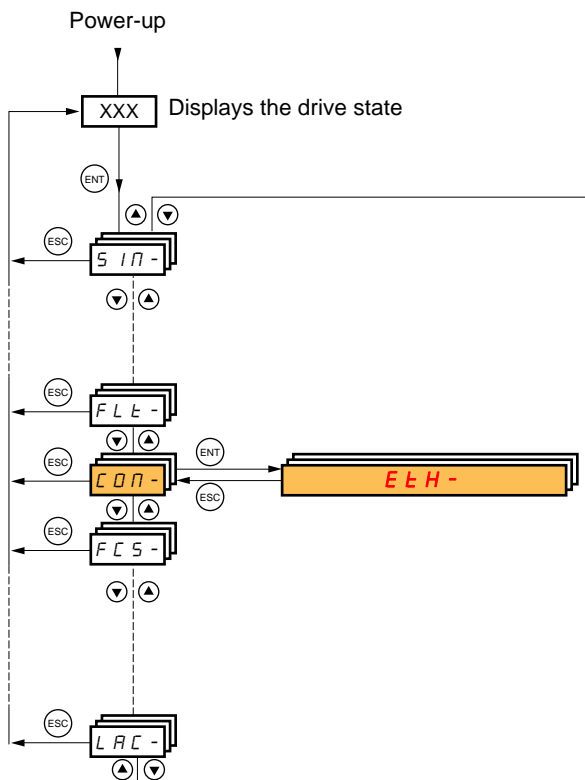

## 8. Ethernet menu

### 8. 3. Ethernet/IP configuration with the HMI

Detail of the Ethernet/IP configuration menu: (All these settings can also be performed from the webserver or PC-Software). In the table, parameters which are not followed by their parameter code (between parenthesis) are not displayed on the 7 segment display of the drive. [1.9 - COMMUNICATION] (C 0 0 -) → menu [ETHERNET RSTP] (E E h r 5)

Parameter	Possible value	Terminal display
[Rate Setting Right] (r d 5 r) This field is used to set the transmission speed and the transmission mode of the card for the right port	0 : Autodetect (default) 1 : 10 Mbps Full 2 : 10 Mbps Half 3 : 100 Mbps Full 4 : 100 Mbps Half (do not use)	[Auto] (A U E 0) [10 Mbps full] ( 1 0 F ) [10 Mbps half] ( 1 0 H ) [100 Mbps full] ( 1 0 0 F ) [100 Mbps half] ( 1 0 0 H )
[Rate Setting] (r d 5) This field is used to set the transmission speed and the transmission mode of the card for the left port.	0 : Autodetect (default) 1 : 10 Mbps Full 2 : 10 Mbps Half 3 : 100 Mbps Full 4 : 100 Mbps Half (do not use)	[Auto] (A U E 0) [10 Mbps full] ( 1 0 F ) [10 Mbps half] ( 1 0 H ) [100 Mbps full] ( 1 0 0 F ) [100 Mbps half] ( 1 0 0 H )
[Actual Rate Right] (R r d r) This field displays the baud rate and the transmission mode currently used by the communication card for the right port. (Display only)	0 : Autodetect 1 : 10 Mbps Full 2 : 10 Mbps Half 3 : 100 Mbps Full 4 : 100 Mbps Half	[Auto] (A U E 0) [10 Mbps full] ( 1 0 F ) [10 Mbps half] ( 1 0 H ) [100 Mbps full] ( 1 0 0 F ) [100 Mbps half] ( 1 0 0 H )
[Actual Rate] (R r d) This field displays the baud rate and the transmission mode currently used by the communication card for the left port. (Display only)	0 : Autodetect 1 : 10 Mbps Full 2 : 10 Mbps Half 3 : 100 Mbps Full 4 : 100 Mbps Half	[Auto] (A U E 0) [10 Mbps full] ( 1 0 F ) [10 Mbps half] ( 1 0 H ) [100 Mbps full] ( 1 0 0 F ) [100 Mbps half] ( 1 0 0 H )
[DEVICE NAME] The device name is required if the card uses DHCP to obtain its IP Address.	16 chars.	[ABC... ]
[Ethernet protocol] (E E H 0) Use this parameter to select the protocol.	0: ModbusTCP (default) 1: EthernetIP	[ModbusTCP] (M b t P) [EthernetIP] (E t I P)
[IP mode] ( I P 0 ) Use this parameter to select the IP address assignment method.	0 : Manu 1 : BOOTP (default value is DHCP) 2 : DHCP	[Fixed] (M A n U) [BOOTP] (b 0 0 t) [DHCP] (d H C P)
[IP card] ( I P C - ) ( I P C 1 ) ( I P C 2 ) ( I P C 3 ) ( I P C 4 ) IP address of the card	These fields are <u>editable</u> when IP mode is set to Fixed address	[139.160.069.241] ( 1 3 9 ) ( 1 6 0 ) ( 0 6 9 ) ( 2 4 1 )
[IP Mask] ( I P 0 - ) ( I P 0 1 ) ( I P 0 2 ) ( I P 0 3 ) ( I P 0 4 ) Subnet mask	These fields are <u>editable</u> when IP mode is set to Fixed address	[255.255.254.0] ( 2 5 5 ) ( 2 5 5 ) ( 2 5 4 ) ( 0 )
[IP Gate] ( I P G - ) ( I P G 1 ) ( I P G 2 ) ( I P G 3 ) ( I P G 4 ) Gateway IP address	These fields are <u>editable</u> when IP mode is set to Fixed address  It could be necessary to set a gateway address if Email services are uses.	[0.0.0.0] ( 0 ) ( 0 ) ( 0 ) ( 0 )
<ul style="list-style-type: none"> <li>• If the address has been given by a BOOTP or a DHCP server, these fields are read only.</li> <li>• After dynamic addressing by a BOOTP or DHCP server, the new address value is displayed.</li> </ul>		
[Services] ( E E ) Enables web server and e-mail server  This parameter is significant at the bit level. Bit 0 and bit 1, other bits are reserved	0 : Web Server and Email functions are disabled. 1: Web Server activated. 2: Email function activated 3: Web server and Email functions are activated	0 1 2 3

## 8. Ethernet menu

---

### Ethernet/IP configuration with the HMI (continued)

Parameter	Possible value	Terminal display
[Config. Assembly] (C I O E) Configured Input/Output assembly (Read only)	0: 20/70 1: 21/71 2: 22/72 3: 23/73 4: 100/101 5: 103/104 6: UnCG (default)	[20/70] (20/70) [21/71] (21/71) [22/72] (22/72) [23/73] (23/73) [100/101] (100/101) [103/104] (103/104) [Unconfig.] (UnCG)
[MAC @] MAC address display	[00-80-F4-XX-XX-XX]	[00-80-F4-XX-XX-XX]

## 8. Ethernet menu

---

### 8. 4. Detail of the configured parameters

#### ■ IP address

##### Assigning IP addresses

3 IP parameters shall be configured:

- The drive IP address (Mandatory)
- The subnet mask (Mandatory)
- The gateway IP address (Optional - for E-Mail service).

These IP addresses can be entered directly:

- Using the integrated display terminal.
- Using the graphic display terminal.
- Or using the PC-Software workshop.

They can be provided by:

- A BOOTP server (correspondence between the MAC address and the IP addresses).
- Or a DHCP server (correspondence between Device Name [DEVICE NAME] and the IP addresses).

The address is assigned according to the IPmode parameter:

IP Mode value	Comments
IP mode = 0	The card uses the address defined in IPC1, IPC2, IPC3, IPC4
IP mode = 1	The card receives its address from a BOOTP server
IP mode = 2	The card receives its address from a DHCP server
And Device name contains a valid name.	

### 8. 5. Assemblies and scanner configuration

The assemblies are chosen at the master controller level (see for example chapter 16 Integration in RSlogix).

For the 4 ODVA set of assemblies (20,21,22,23,70,71,72,73) there are no more configuration to do at the communication scanner level.

For the Schneider-Electric assembly (100,101) and Allen Bradley® assembly (103,104):

- configure at the drive level the size of the assembly,
- define the mapping of the additional parameters.

# 9. Configuration of the assemblies

## 9. 1. Configuration of the assemblies: overview

VW3 A3320 EtherNet/IP communication card  
Features overview

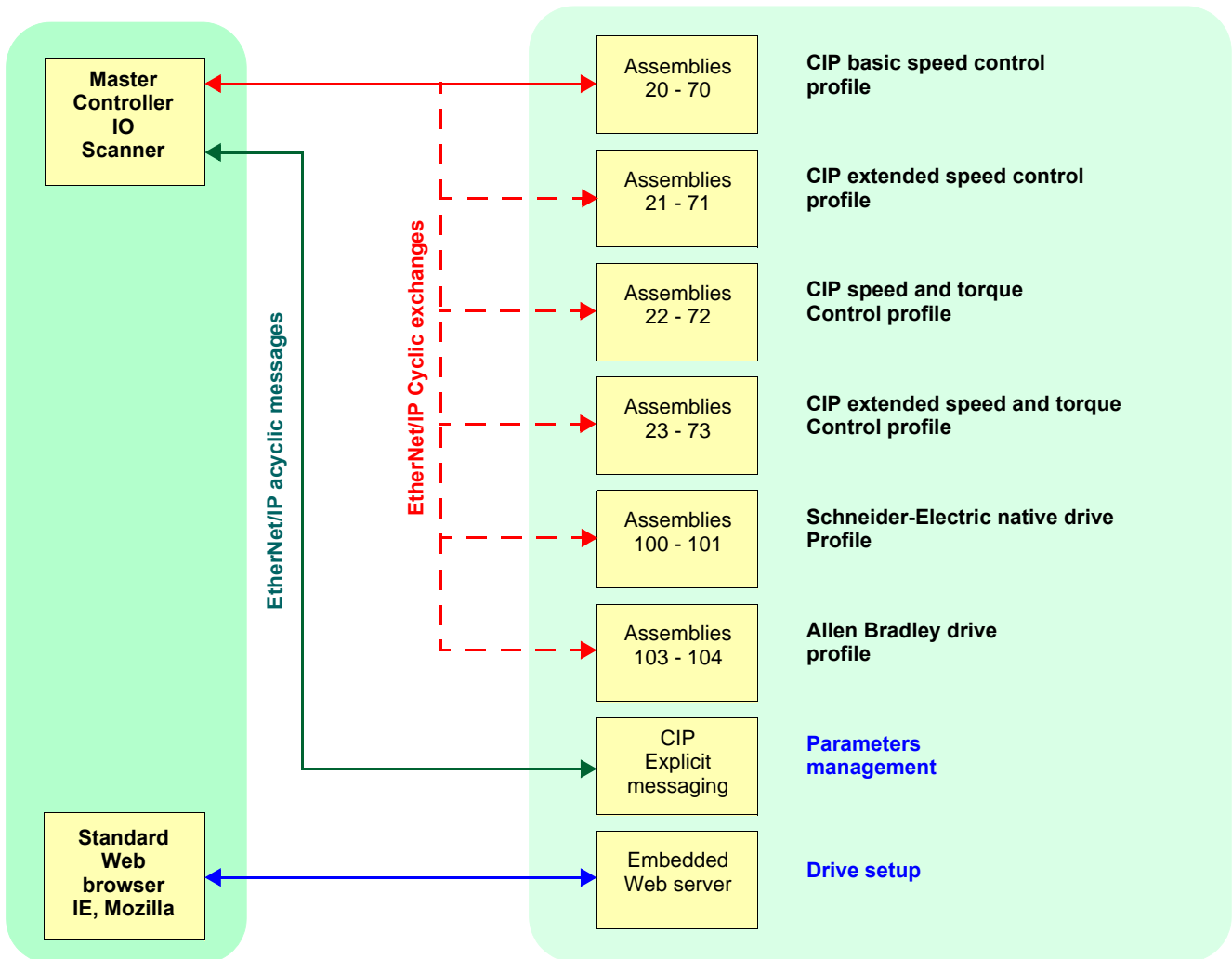

# 9. Configuration of the assemblies

## 9. 2. Configuration of the assembly (100,101) Schneider-Electric native profile

The size of the assembly is fixed and is equal to 8.

The mapping of the other parameters is made with the communication scanner :

The configuration of the addresses defined with NCAx and NMAx can be made with the graphic keypad:

For assembly 100 : [1.9- COMMUNICATION] ( [ C O N - ] ) menu, [COM.SCANNER OUTPUT] ( [ O E S - ] ) submenu.

For assembly 101 : [1.9- COMMUNICATION] ( [ C O N - ] ) menu, [COM.SCANNER INPUT] ( [ I E S - ] ) submenu.

See menu [1.2 MONITORING] > COMMUNICATION MAP to monitor the communication scanner.

See also "Configuring the communication scanner" page 20.

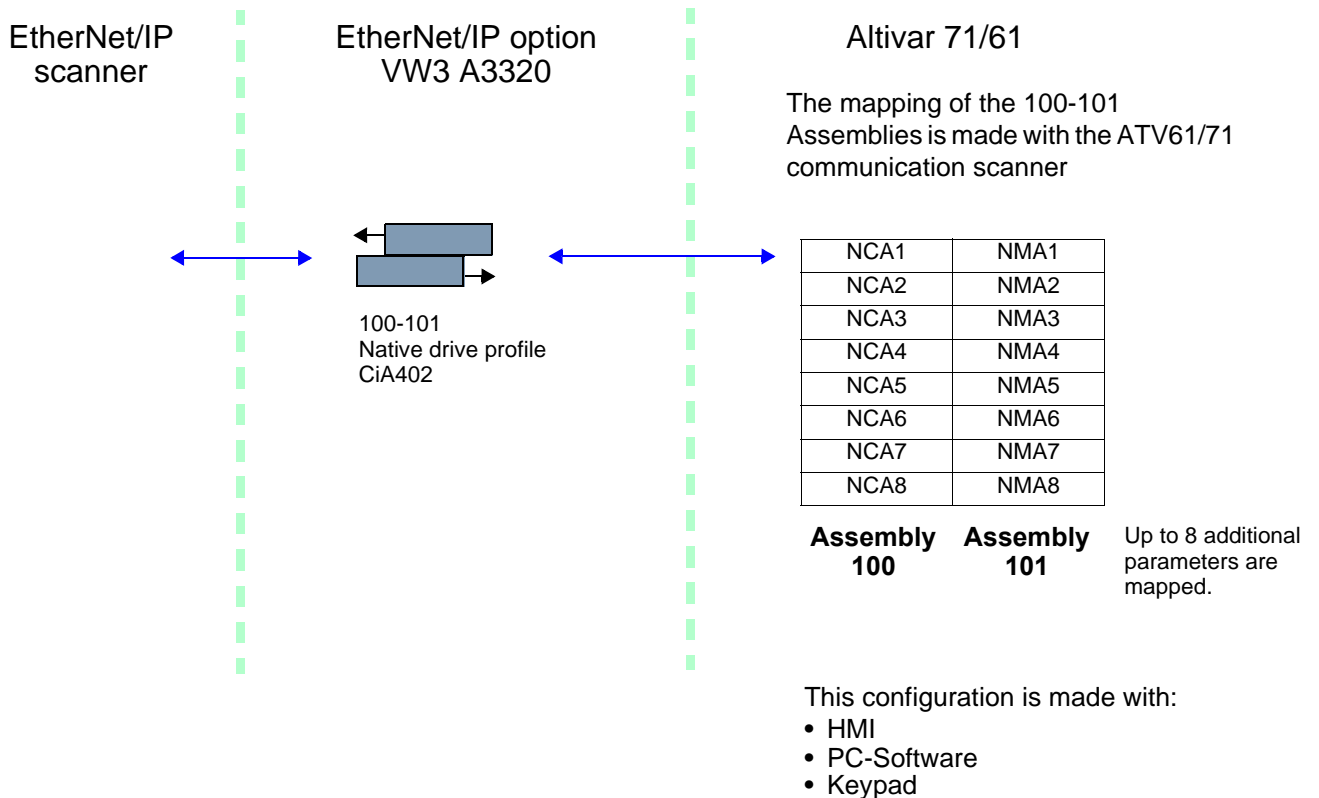

Here is an example of the configuration of the assemblies 100, 101 from RSLogix software:

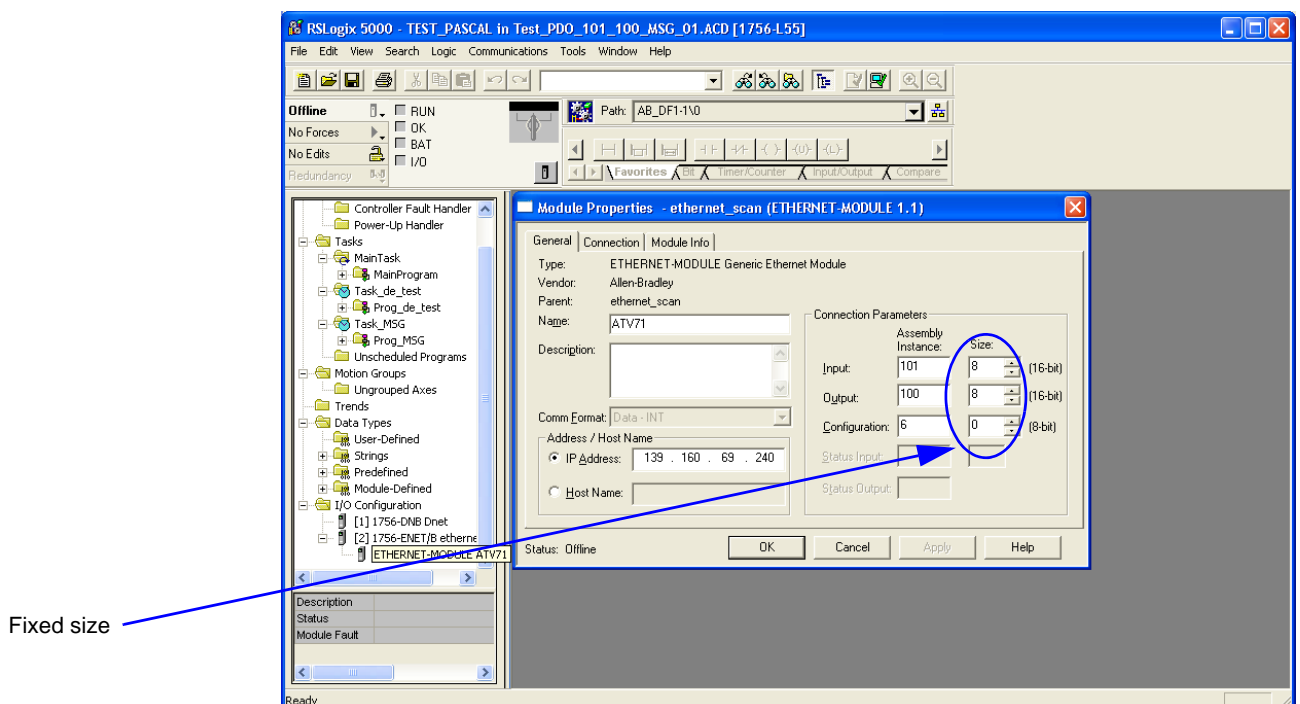

# 9. Configuration of the assemblies

## 9. 3. Configuration of the assembly (103,104) Allen Bradley® profile

The size of the assembly is selectable from 2 to 10 words.  
 The 2 first words of the input assembly are fixed: Control word, Speed setpoint.  
 The 2 first words of the output assembly are fixed: Status word, Actual Speed.

**NCA1 and NCA2 are already configured (default settings of the drive). When configuring this assembly set to handly remove the default assignment of NCA1 and NCA2: By setting NCA1 and NCA2 to a null address or by configuring this two address to other required parameters of the drive.**

This will avoid a conflict between NCA1 and the control word of the profile (located in the first word of the assembly 103).  
 The configuration of the addresses defined with NCAx and NMAx can be made with the graphic keypad:  
 For assembly 103 : [1.9- COMMUNICATION] ( C O N - ) menu, [COM.SCANNER OUTPUT] ( O C S - ) submenu.  
 For assembly 104 : [1.9- COMMUNICATION] ( C O N - ) menu, [COM.SCANNER INPUT] ( I C S - ) submenu.  
 See menu [1.2 MONITORING] > COMMUNICATION MAP to monitor the communication scanner.  
 See also "Configuring the communication scanner" page 20  
 The mapping of the other parameters is made with the EtherNet/IP scanner:

EtherNet/IP scanner

EtherNet/IP option  
 VW3 A3320

Altivar 71/61

The mapping of the 103-104  
 Assemblies is made with the  
 option card EtherNet/IP scanner

Control Word	Status Word
Set point	Actual speed
NCA1	NMA1
NCA2	NMA2
NCA3	NMA3
NCA4	NMA4
NCA5	NMA5
NCA6	NMA6
NCA7	NMA7
NCA8	NMA8

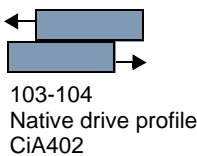

This configuration is made with:

- Webservice
- PC-Software

**Assembly 103    Assembly 104**  
 Up to 8 additional parameters are mapped.

Here is an example of the configuration of the assemblies 103, 104 from RSLogix software

The sizes indicated must be adjusted according to the settings defined with the EtherNet/IP scanner setup (webservice or PC-Software).

**Note:**

- The size of the assembly cannot be modified dynamically; such change requires a power ON.
- Given that assemblies 103 and 104 uses NCAx and NMAx, the configuration edited with the webservice or PC-Software are also applied to the communication scanner of the drive (like assemblies 100 and 101).

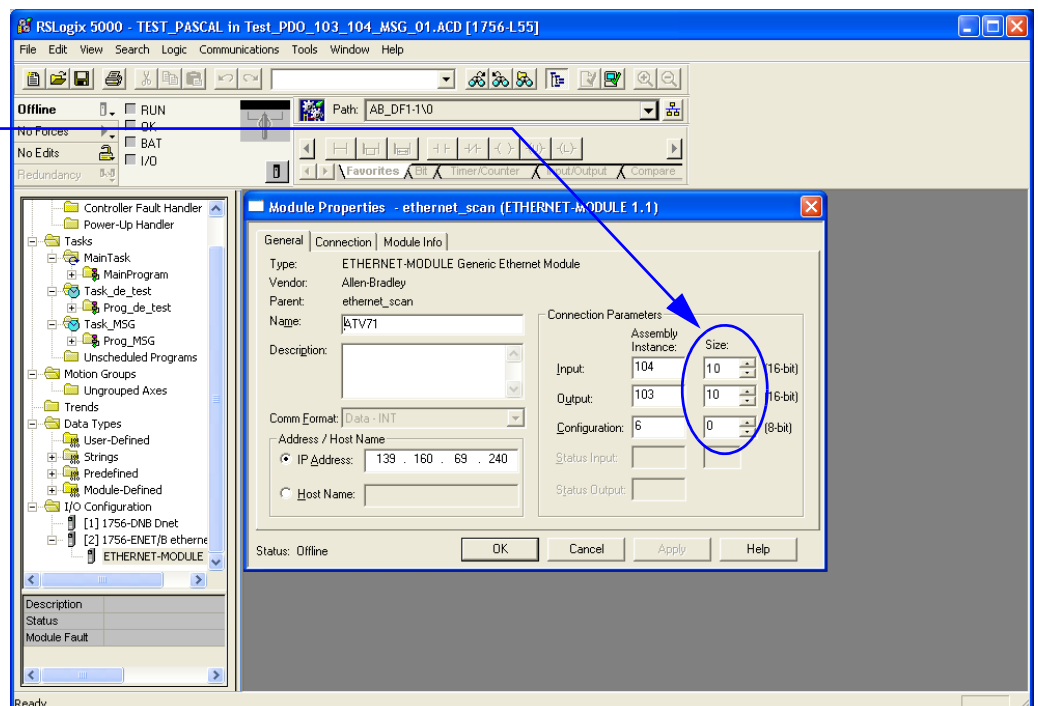

## 9. Configuration of the assemblies

### 9. 4. Configuring the communication scanner

You need to read this chapter only if you use the assemblies 100 or 101 that use the drive communication scanner.

The variables exchanged by the output assembly 100 and input assembly 101 are selected by configuring the communication scanner.

The 8 output variables are assigned by means of the 8 parameters [Scan. Out● address] (n L R ●). They are configured using the graphic display terminal via the [1.9 - COMMUNICATION] (L D P -) menu, [COM. SCANNER OUTPUT] (D C S -) submenu.

The 8 input variables of the assembly 101 are assigned by means of the 8 parameters [Scan. In● address] (n P R ●). They are configured using the graphic display terminal via the [1.9 - COMMUNICATION] (L D P -) menu, [COM. SCANNER INPUT] (I C S -) submenu.

Enter the logic address of the parameter (see the Communication parameters manual).

If a parameter [Scan. Out● address] (n L R ●) or [Scan. In● address] (n P R ●) is equal to zero, the corresponding period variable is not used by the drive.

These 8 assignment parameters are described in the tables below:

Parameter name	Output assembly 100	Default assignment
[Scan. Out1 address] (n L R 1)		NCA1 = 8501
[Scan. Out2 address] (n L R 2)		NCA2 = 8602
[Scan. Out3 address] (n L R 3)		NCA3 = not used
[Scan. Out4 address] (n L R 4)		NCA4 = not used
[Scan. Out5 address] (n L R 5)		NCA5 = not used
[Scan. Out6 address] (n L R 6)		NCA6 = not used
[Scan. Out7 address] (n L R 7)		NCA7 = not used
[Scan. Out8 address] (n L R 8)		NCA8 = not used

Parameter name	Input assembly 101	Default assignment
[Scan. In1 address] (n P R 1)		NMA1=3201
[Scan. In2 address] (n P R 2)		NMA2=8604
[Scan. In3 address] (n P R 3)		NMA3=not used
[Scan. In4 address] (n P R 4)		NMA4=not used
[Scan. In5 address] (n P R 5)		NMA5=not used
[Scan. In6 address] (n P R 6)		NMA6=not used
[Scan. In7 address] (n P R 7)		NMA7=not used
[Scan. In8 address] (n P R 8)		NMA8=not used

Example of configuration via the graphic display terminal:

RDY	NET	+0.00Hz	0A
COM. SCANNER INPUT			<input type="checkbox"/>
Scan. In1 address	:		3204
Scan. In2 address	:		3206
Scan. In3 address	:		0
Scan. In4 address	:		0
Scan. In5 address	:		0
Code		Quick	<input checked="" type="checkbox"/>
Scan. In6 address	:		0
Scan. In7 address	:		0
Scan. In8 address	:		0

RDY	NET	+0.00Hz	0A
COM. SCANNER OUTPUT			<input type="checkbox"/>
Scan. Out1 address	:		9001
Scan. Out2 address	:		9002
Scan. Out3 address	:		0
Scan. Out4 address	:		0
Scan. Out5 address	:		0
Code		Quick	<input checked="" type="checkbox"/>
Scan. Out6 address	:		0
Scan. Out7 address	:		0
Scan. Out8 address	:		0

**Note:**

All modifications to parameters [Scan. Out● address] (n L R ●) or [Scan. In● address] (n P R ●) must be made with the motor stopped. The master PLC program should be updated to take account of this modification.

## 9. Configuration of the assemblies

---

### 9.5. Configuring the control

#### ■ Principle

By the configuration of the control, it is possible to decide from what channel the drive receives its commands and setpoint, either permanently or depending on a switching command.

Numerous configurations are possible. For more information, refer to the Programming manual and Communication parameters manual. The following configurations are some of the possibilities available.

#### □ Control with communication scanner

If the default assemblies (100, 101) are selected, all possibilities of Altivar 61/71 drive are available.

It is possible to use all profiles and modes of the drive:

- I/O profile,
- Drivecom profiles with separate or non separate mode.

By the configuration of the communication scanner, it is possible to assign any relevant parameter of the drive to the 8 input and 8 output variables of the assemblies.

See the input / output interface with the PLC can be fully customised depending on the application.

The use of the communication scanner is also the best way to interface with a "Controller Inside" card.

#### □ Control according to ODVA AC drive profile

The ODVA AC drive profile is activated when one of the following assemblies is selected:

- 20: Basic speed control output
- 21: Extended speed control output
- 22: Speed and torque control output
- 23: Extended speed and torque control output
- 70: Basic speed control input
- 71: Extended speed control input
- 72: Speed and torque control input
- 73: Extended speed and torque control input

The advantage of using the ODVA drive profile standard is the interchangeability with other brands.

The drive must be configured in the Drivecom profile with separate mode.

The EtherNet/IP card translates the commands, behaviour and monitoring information from ODVA profile (on the network) to the Drivecom profile (in the drive).

#### □ Control according to Allen-Bradley® drive profile

The Allen-Bradley® Drive profile is activated when one of the following assemblies is selected:

- 103: Allen-Bradley® drive output
- 104: Allen-Bradley® drive input

If you need to replace Allen-Bradley® drives, in an existing application, this profile is a good way to minimise the modifications.

The drive must be configured in the Drivecom profile with separate mode.

The EtherNet/IP card translates the commands, behaviour and monitoring information from Allen-Bradley® drive profile (on the network) to the Drivecom profile (in the drive).

## 9. Configuration of the assemblies

### ■ Available configurations

#### □ If you use the communication scanner:

- 100: Communication scanner output
- 101: Communication scanner input there is no limitation in the configuration of the control.

The examples below are only possible if you use the communication scanner.

#### □ If you use the ODVA AC drive profile or Allen-Bradley® Drive profile, that is, the assemblies:

- 20: Basic speed control output
- 21: Extended speed control output
- 22: Speed and torque control output
- 23: Extended speed and torque control output
- 70: Basic speed control input
- 71: Extended speed control input
- 72: Speed and torque control input
- 73: Extended speed and torque control input
- 103: Allen-Bradley® drive output
- 104: Allen-Bradley® drive input

Parameter	Permitted value	Comment
Profile	Drivecom profile separate	The run commands are in Drivecom profile, the command and the reference can come from different channels.
Setpoint 1 configuration	Network card	Setpoint 1 comes from EtherNet/IP.
Setpoint 1B configuration	Terminals	Setpoint 2 comes from terminals (AI1 or AI2).
Setpoint 2 configuration	Terminals	Setpoint 2 comes from terminals (AI1 or AI2).
Command 1 configuration	Network card	Command 1 comes from EtherNet/IP.
Command 2 configuration	Terminals	Command 2 comes from terminals.
Command switching	Network card bit 12	Bit 12 of the control word switches the command.
Setpoint switching	Network card bit 13	Bit 13 of the control word switches the setpoint (1 <-> 1B or 1 <-> 2).

Configuration via the graphic display terminal or the integrated display terminal:

**Case 1:** Setpoint 1B is connected to the functions (Summing, PID, etc) which remain active even after switching.

Menu	Parameter	Permitted value
[1.6 - COMMAND] (C E L -)	[Profile] (C H C F)	[Separate] (S E P)
	[Ref.1 channel] (F r 1)	[Com. card] (n E E)
	[Ref.1B channel] (F r 1b)	[Ref. AI1] (A I 1) or [Ref. AI2] (A I 2)
	[Cmd channel 1] (C d 1)	[Com. card] (n E E)
	[Cmd channel 2] (C d 2)	[Terminals] (E E r)
	[Cmd switching] (C C 5)	[C312] (C 3 1 2)
[1.7 APPLICATION FUNCT.] (F U n -) [REFERENCE SWITCH.]	[Ref 1B switching] (r C b)	[C313] (C 3 1 3)

**Case 2:** Setpoint 2 is directly connected to the drive reference limit. If switching is performed, the functions that affect the reference (summing, PID, etc.) are inhibited.

Menu	Parameter	Permitted value
[1.6 - COMMAND] (C E L -) [1.7 APPLICATION FUNCT.] (F U n -) [REFERENCE SWITCH.]	[Profile] (C H C F)	[Separate] (S E P)
	[Ref.1 channel] (F r 1)	[Com. card] (n E E)
	[Ref.2 channel] (F r 2)	[Ref. AI1] (A I 1) or [Ref. AI2] (A I 2)
	[Cmd channel 1] (C d 1)	[Com. card] (n E E)
	[Cmd channel 2] (C d 2)	[Terminals] (E E r)
	[Cmd switching] (C C 5)	[C312] (C 3 1 2)
	[Ref. 2 switching] (r F C)	[C313] (C 3 1 3)

**Note:** It is not possible to configure the display terminal as a channel.

To switch to the display terminal, use the function force local and assign the parameter [Forced local Ref.] to [HMI] (L C C).

## 9. Configuration of the assemblies

### ■ Control via EtherNet/IP in I/O profile

**Note:** This configuration can only be used if the communication scanner assemblies (100 and 101) are selected.

The command and the setpoint come from EtherNet/IP.  
Control is in I/O profile.

Configure the following parameters:

Parameter	Value	Comment
Profile	I/O profile	The run command is simply obtained by bit 0 of the command word.
Setpoint 1 configuration	Network card	The setpoint comes from EtherNet/IP.
Command 1 configuration	Network card	The command comes from EtherNet/IP.

Configuration via the graphic display terminal or the integrated display terminal:

Menu	Parameter	Value
[1.6 - COMMAND] (C E L -)	[Profile] (C H C F)	[I/O profile] ( I 0)
	[Ref.1 channel] (F r 1)	[Com. card] (n E k)
	[Cmd channel 1] (C d 1)	[Com. opt card] (n E k)

### ■ Control via EtherNet/IP or via the terminals in I/O profile

**Note:** This configuration can only be used if the communication scanner assemblies (100 and 101) are selected.

The command and the setpoint both come from EtherNet/IP or the terminals. Input LI5 at the terminals is used to switch between EtherNet/IP and the terminals.  
Control is in I/O profile.

Configure the following parameters:

Parameter	Value	Comment
Profile	I/O profile	The run command is simply obtained by bit 0 of the control word.
Setpoint 1 configuration	Network card	Setpoint 1 comes from EtherNet/IP.
Setpoint 1B configuration	Analog input 1 on the terminals	Setpoint 1B comes from input AI1 on the terminals.
Setpoint switching	Input LI5	Input LI5 switches the setpoint (1 ↔ 1B).
Command 1 configuration	Network card	Command 1 comes from EtherNet/IP.
Command 2 configuration	Terminals	Command 2 comes from the terminals.
Command switching	Input LI5	Input LI5 switches the command.

**Note:** Setpoint 1B is connected to the functions (Summing, PID, etc) which remain active even after switching.

Configuration via the graphic display terminal or the integrated display terminal:

Menu	Parameter	Value
[1.6 - COMMAND] (C E L -)	[Profile] (C H C F)	[I/O profile] ( I 0)
	[Ref.1 chan] (F r 1)	[Com. card] (n E k)
	[Cmd channel 1] (C d 1)	[Com. card] (n E k)
	[Cmd channel 2] (C d 2)	[Terminals] (k E r)
	[Cmd switching] (C C S)	[LI5] (L 15)
[1.7 APPLICATION FUNCT.] (F U n -) [REFERENCE SWITCH.]	[Ref.1B chan] (F r 1b)	[AI1 ref.] (A 1 1)
	[Ref 1B switching] (r C b)	[LI5] (L 15)

## 9. Configuration of the assemblies

### ■ Control via EtherNet/IP in Drivecom profile

**Note:** This configuration can only be used if the communication scanner assemblies (100 and 101) are selected.

The command and the setpoint come from EtherNet/IP.

Configure the following parameters:

Parameter	Value	Comment
Profile	Separate Drivecom profile	The run commands are in Drivecom profile, the command and the setpoint can come from different channels.
Setpoint 1 configuration	Network card	The setpoint comes from EtherNet/IP.
Command 1 configuration	Network card	Command 1 comes from EtherNet/IP.

Configuration via the graphic display terminal or the integrated display terminal:

Menu	Parameter	Value
[1.6 - COMMAND] (E L L -)	[Profile] (C H C F)	[Separate] (S E P)
	[Ref.1 chan] (F r 1)	[Com. card] (n E E)
	[Cmd channel 1] (C d 1)	[Com. card] (n E E)

### ■ Control via EtherNet/IP or the terminals in Drivecom profile

**Note:** This configuration can only be used if the communication scanner assemblies (100 and 101) are selected.

The command and the setpoint both come from EtherNet/IP or the terminals. Input LI5 at the terminals is used to switch between EtherNet/IP and the terminals.

Configure the following parameters:

Parameter	Value	Comment
Profile	Separate Drivecom profile	The run commands are in Drivecom profile, the command and the setpoint can come from different channels.
Setpoint 1 configuration	Network card	Setpoint 1 comes from EtherNet/IP.
Setpoint 2 configuration	Analog input 1 on the terminals	Setpoint 2 comes from input AI1 on the terminals.
Setpoint switching	Input LI5	Input LI5 switches the setpoint (1 ↔ 2) and the command.
Command 1 configuration	Network card	Command 1 comes from EtherNet/IP.
Command 2 configuration	Terminals	Command 2 comes from the terminals.
Command switching	Input LI5	Input LI5 switches the command.

**Note:** Setpoint 2 is directly connected to the drive reference limit. If switching is performed, the functions that affect the reference (summing, PID, etc) are inhibited.

Configuration via the graphic display terminal or the integrated display terminal:

Menu	Parameter	Value
[1.6 - COMMAND] (E L L -)	[Profile] (C H C F)	[Separate] (S E P)
	[Ref.1 chan] (F r 1)	[Com. card] (n E E)
	[Ref.2 chan] (F r 2)	[AI1 ref.] (A I 1)
	[Ref. 2 switching] (r F C)	[LI5] (L I 5)
	[Cmd channel 1] (C d 1)	[Com. card] (n E E)
	[Cmd channel 2] (C d 2)	[Terminals] (E E r)
	[Cmd switching] (C C S)	[LI5] (L I 5)

## 9. Configuration of the assemblies

### ■ Control in Drivecom profile via EtherNet/IP and setpoint switching at the terminals

**Note:** This configuration can only be used if the communication scanner assemblies (100 and 101) are selected.

The command comes from EtherNet/IP.

The setpoint comes either from EtherNet/IP or from the terminals. Input LI5 at the terminals is used to switch the setpoint between EtherNet/IP and the terminals.

Control is in Drivecom profile.

Configure the following parameters:

Parameter	Value	Comment
Profile	Separate Drivecom profile	The run commands are in Drivecom profile, the command and the setpoint can come from different channels.
Setpoint 1 configuration	Network card	Setpoint 1 comes from EtherNet/IP.
Setpoint 1B configuration	Analog input 1 on the terminals	Setpoint 1B comes from input AI1 on the terminals.
Setpoint switching	Input LI5	Input LI5 switches the setpoint (1 ↔ 1B).
Command 1 configuration	Network card	Command 1 comes from EtherNet/IP.
Command switching	Channel 1	Channel 1 is the command channel.

**Note:** Setpoint 1B is connected to the functions (summing, PID, etc) that remain active, even after switching.

Configuration via the graphic display terminal or the integrated display terminal:

Menu	Parameter	Value
[1.6 - COMMAND] (CLL -)	[Profile] (CHF)	[Separate] (SEP)
	[Ref.1 chan] (Fr1)	[Com. card] (nEk)
	[Cmd channel 1] (Cd1)	[Com. card] (nEk)
	[Cmd switching] (CS)	[ch1 active] (Cd1)
[1.7 APPLICATION FUNCT.] (Fun -) [REFERENCE SWITCH.]	[Ref.1B chan] (Fr1b)	[AI1 ref.] (R11)
	[Ref 1B switching] (rCb)	[LI5] (LI5)

# 10. Fault management

## 10.1. Fault management

An EtherNet/IP time out is triggered if the card does not receive any cyclic messages (regardless within a predefined time period). This period is managed by the EtherNet/IP controller (not by the drive) and is configured in its module properties box. The duration of the time out is defined by the RPI (Request packet intervals). The RPI minimum value supported is 15 ms.

If the card is controlled by explicit messages (without periodic exchanges) There is no control of the communication time-out.

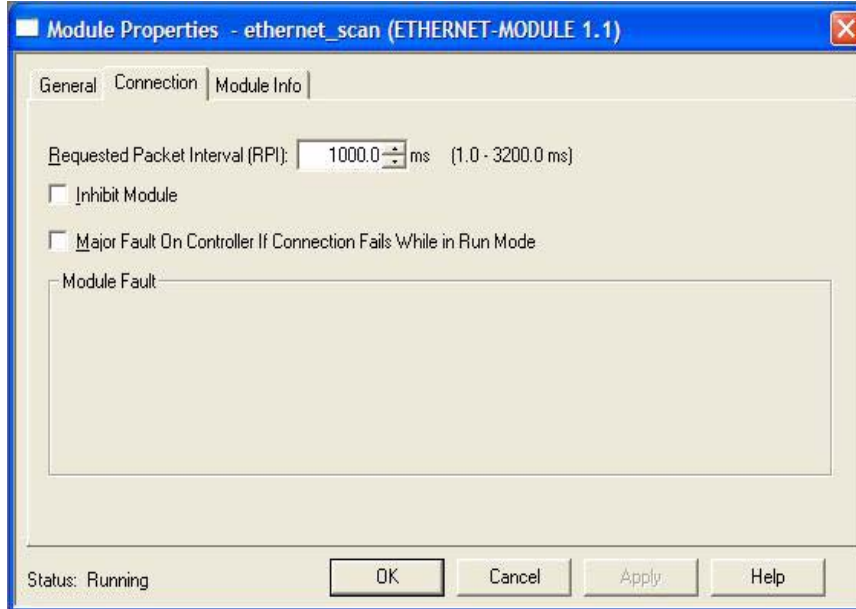

The **response** of the drive in case of such event can be configured.

Configuration can be performed using the graphic display terminal or integrated display terminal using the **[Network fault mgt] (ELL)** parameter in the **[1.8 FAULT MANAGEMENT] (FLE-)** menu, **[COM. FAULT MANAGEMENT] (ELL-)** submenu.

RDY	NET	+0.00Hz	0A
COM. FAULT MANAGEMENT <input type="checkbox"/>			
Network fault mgt	:		Freewheel
CANopen fault mgt	:		Freewheel
Modbus fault mgt	:		Freewheel
	:		
	:		
	:		
Code		Quick	<input checked="" type="checkbox"/>

The values of the **[Network fault mgt] (ELL)** parameter, trigger a **[COM. network] (ENF)** drive fault, are:

Value	Meaning
<b>[Freewheel] (YES)</b>	Freewheel stop (factory setting)
<b>[Ramp stop] (RPP)</b>	Stop on ramp
<b>[Fast stop] (FSE)</b>	Fast stop
<b>[DC injection] (DEI)</b>	DC injection stop

The values of the **[Network fault mgt] (ELL)** parameter, which do not trigger a drive fault, are:

Value	Meaning
<b>[Ignore] (ND)</b>	Fault ignored
<b>[Per STT] (SET)</b>	Stop according to configuration of <b>[Type of stop] (SET)</b>
<b>[Fallback spd] (LFF)</b>	Switch to fallback speed, maintained as long as the fault is present and the run command is not disabled.
<b>[Spd maint.] (RLS)</b>	The drive maintains the speed at the time the fault occurred, as the fault persists and the run command has not been removed.

The fallback speed can be configured via the **[Fallback spd] (LFF)** parameter in the **[1.8 FAULT MANAGEMENT] (FLE-)** menu.

# 10. Fault management

## 10. 2. Status of the LEDs

The VW3 A3320 Ethernet/IP card features 5 LEDs, which are visible through the Altivar 61/71 cover.

1.1  
1.2  
1.3  
1.4  
1.5

2.1 Port 1 activity  
2.2 Port 2 activity  
2.3 Link status  
2.4 NS "Network status"  
2.5 MS "Module status"

The 2 first LEDs are respectively dedicated to each Ethernet port.  
The third LED is relative to the IP level.  
The 2 last LEDs are specific to EtherNet/IP and CIP communication protocol.

LED	Color/ state	Description
2.1	Off	No link
	Flashing Green/yellow	Power up testing.
	Green ON	Link at 100 Mbps.
	Yellow ON	Link at 10 Mbps.
	Green BLINK	Activity at 100 Mbps.
	Yellow BLINK	Activity at 10 Mbps.
2.2	Off	No link
	Flashing Green/yellow	Power up testing.
	Green ON	Link at 100 Mbps.
	Yellow ON	Link at 10 Mbps.
	Green BLINK	Activity at 100 Mbps.
	Yellow BLINK	Activity at 10 Mbps.
2.3	Off	Physical connections unplugged - No IP address obtained
	Flashing Green/red	Power up testing.
	Green ON	At least one port is connected and an IP address has been obtained.
	Green flashing 3 times	All ports are unplugged, but the card has an IP address.
	Green flashing 4 times	Error: Duplicated IP address (1)
	Green flashing 5 times	The card is performing a BOOTP or DHCP sequence
2.4 "NS"	Off	The device does not have an IP address or powered off.
	Flashing Green/red	Power up testing.
	Green ON	The device has at least one established connection (even to the Message Router).
	Green flashing	The device has not established connections, but has obtained an IP address.
	Red flashing	One or more of the connections in which this device is the target has timed out. This shall be left only if all timed-out connections are reestablished or if the device is reset.
	Red ON	The device has detected that its IP address is already in use (1).
2.5 "MS"	Off	No power is supplied to the device
	Flashing Green/red	Power Up testing.
	Green ON	The device is operating correctly.
	Green flashing	The device has not been configured.
	Red flashing	The device has detected a recoverable minor fault.
	Red ON	The device has detected a non-recoverable major fault (1).

(1) In case of duplicate IP Address, the led 2.3 is green flashing 4 times, led 2.4 and 2.5 are solid red.

# 11. Configuration of monitored parameters

It is possible to select up to 4 parameters to display their values in the [1.2 - MONITORING] menu on the graphic display terminal.

The selection is made via the [6 - MONITORING CONFIG.] menu, [6.3 - COM. MAP CONFIG.] submenu.

Each parameter in the range [Address 1 select.] ... [Address 4 select.] is used to select the parameter logic address. Select an address of zero to disable the function.

In the example given here, the monitored words are:

- Parameter 1 = Motor current (LCR): logic address 3204; signed decimal format.
- Parameter 2 = Motor torque (OTR): logic address 3205; signed decimal format.
- Parameter 3 = Last fault occurred (LFT): logic address 7121; hexadecimal format.
- Disabled parameter: address 0; default format: hexadecimal format.

RDY	NET	+0.00Hz	0A
6.3 COM. MAP CONFIG.			<input type="checkbox"/>
Word 1 add. select.	:		3204
Format word 1	:		Signed
Word 2 add. select.	:		3205
Format word 2	:		Signed
Word 3 add. select.	:		7121
<b>Code</b>		<b>Quick</b>	<input checked="" type="checkbox"/>
Format word 33	:		Hex
Word 4 add. select.	:		0
Format word 4	:		Hex

One of the three display formats below can be assigned to each monitored word:

Format	Range	Terminal display
Hexadecimal	0000 ... FFFF	[Hex]
Signed decimal	-32,767 ... 32,767	[Signed]
Unsigned decimal	0 ... 65,535	[Unsigned]

## 12. Standard Web server

### 12. 1. Webserver function

Menu	Page	Function
HOME	English	Home page
MONITORING	Drive monitor	Display of the main drive parameters (motor speed, state of drive logic and analog I/O, status)
	Drive parameters	Display and modification (password-protected) of the drive parameters, arranged by category
	Drive chart	Display of two drive parameters (speed, voltage, etc.) in the form of an oscilloscope type time chart
DIAGNOSTICS	Ethernet	Display and resetting of the communication statistics
	Modbus TCP	Display and resetting of the Modbus TCP communication statistics
	Ethernet/IP	Display and resetting of the etherNET/IP communication statistics
	RSTP port	Display and resetting of the RSTP ports communication statistics
	RSTP bridge	Display and resetting of the RSTP bridge communication statistics
SETUP	Network & protocol	Changing the protocol and the communication settings
	RSTP	Changing the bridge and port settings for RSTP function
	Modbus TCP scanner	Changing the assignment of the Modbus TCP IO Scanning periodic variables
	EtherNET/IP scanner	Changing the assignment of the EtherNET/IP IO Scanning periodic variables
	FDR Agent	Management of the FDR agent of th communication card
	Email	Changing the Email alert function settings
	Security	Changing the username and password for monitoring and write access
DOCUMENTATION	References	Link to the site <a href="http://www.schneider-electric.com">http://www.schneider-electric.com</a>

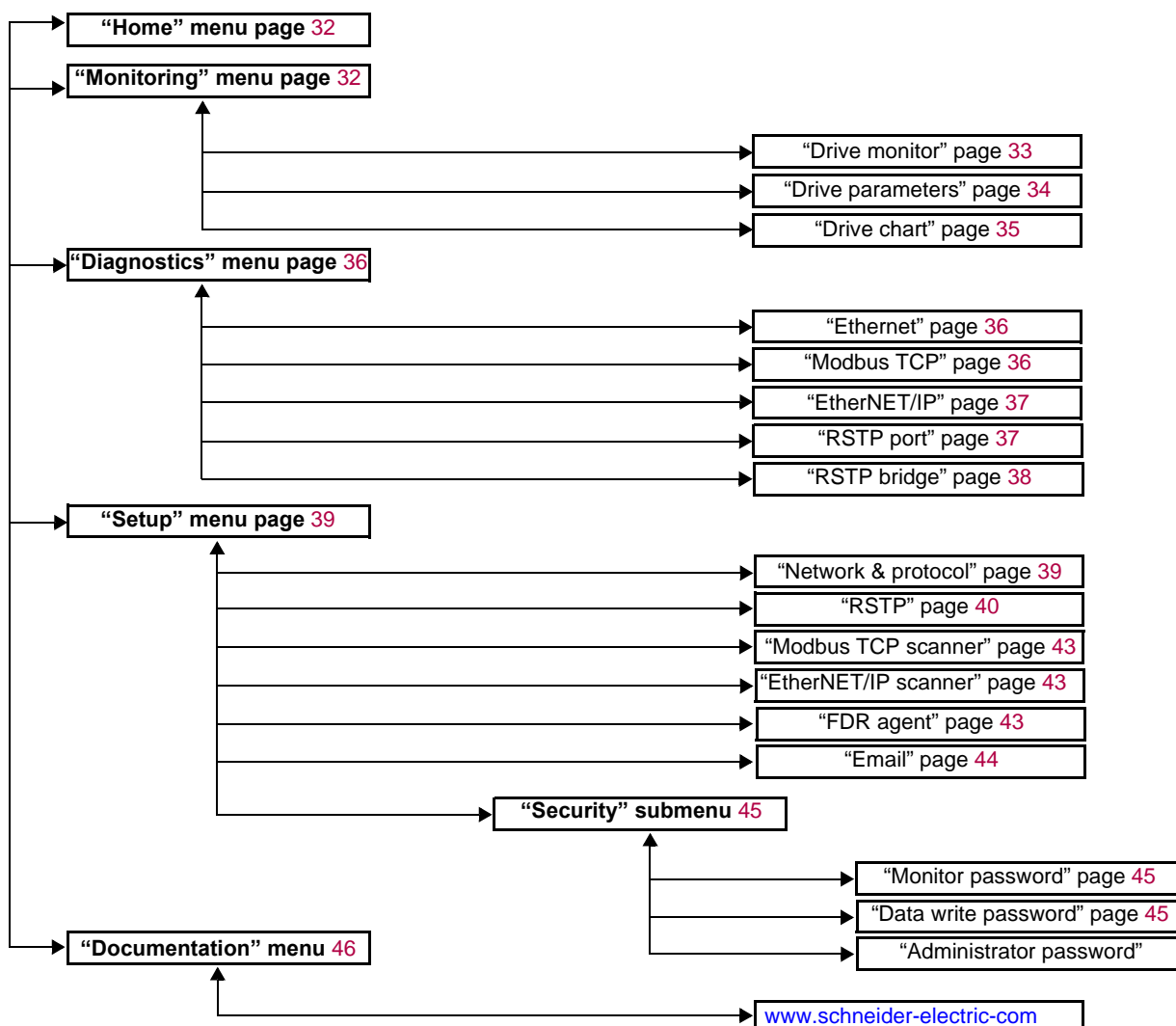

# 12. Standard Web server

---

## 12. 2. Applets

The Web server downloads Java programs called “applets” to your computer. These applets communicate with the drive using Modbus services (on port 502), thus establishing one or more connections between the computer and the drive. Until an applet has been fully transmitted from the drive to the browser, a gray rectangle appears in the place reserved for it in the page.

The applet connects when the page is opened and remains connected until the page is closed.

Display problems can appear with the internet Explore default JVM. Use the SUN Java virtual machine V1.6.

The applets associated with the Web pages monitor communication with the drive. When the drive no longer responds to requests to update the data, the message “Link down” is displayed in one field and all the other field contents are emptied.

Subsequently, the description of each page indicates the data refresh period requested by the applet loaded on the computer. The refresh period actually observed depends on:

- The performance of the computer on which the Web browser is running.
- The communication system response time.
- The amount of data to be refreshed on the page.

## 12. Standard Web server

### 12. 3. Access to the Web server

To connect to the Web server of a drive located, for example, at IP address 139.160.69.241 enter the URL “<http://139.160.69.241/>” in the address bar of a Web browser.

When the browser first connects to the drive Web server, it requests entry of a user name and a password (HTTP password).

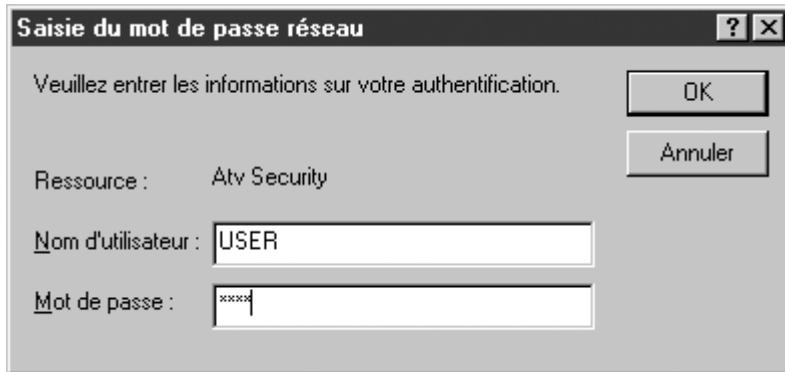

The image shows a dialog box titled "Saisie du mot de passe réseau" (Network password entry). The text inside says "Veuillez entrer les informations sur votre authentification." (Please enter authentication information). There are two buttons: "OK" and "Annuler" (Cancel). Below the text, the "Ressource" (Resource) is listed as "Atv Security". There are two input fields: "Nom d'utilisateur" (Username) with the text "USER" and "Mot de passe" (Password) with masked characters "xxxx".

By default, the user name and the password (HTTP password) are both “USER” (upper case).

If authentication is accepted, the home page is displayed. If not, after three failed attempts, access to this page is denied:

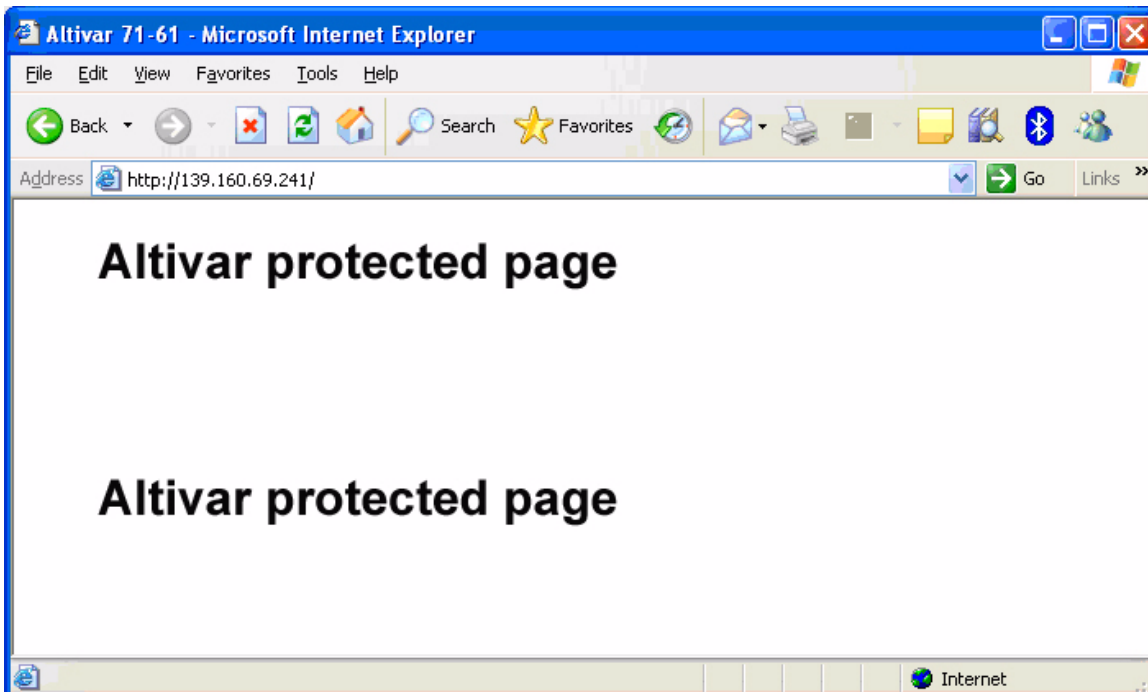

To attempt a new connection to the drive server home page, simply refresh the Web browser display (F5 key or “Refresh” button, for example).

## 12. Standard Web server

### 12. 4. Web server user interface

All the drive Web server pages have the same appearance:

1 A bar at the top containing links to HTML pages for the main menus: "Home", "Documentation", "Monitoring, "setup", etc.

This bar is the same regardless of which HTML page is being viewed.

**Note:** The "Control" and "Maintenance" menus are inoperative and grayed-out. They only appear because of the "Transparent Ready" common interface.

2 A menu down the left-hand side which displays links to the HTML pages available in the selected menu.

3 The center part of the window displays the information for the selected page.

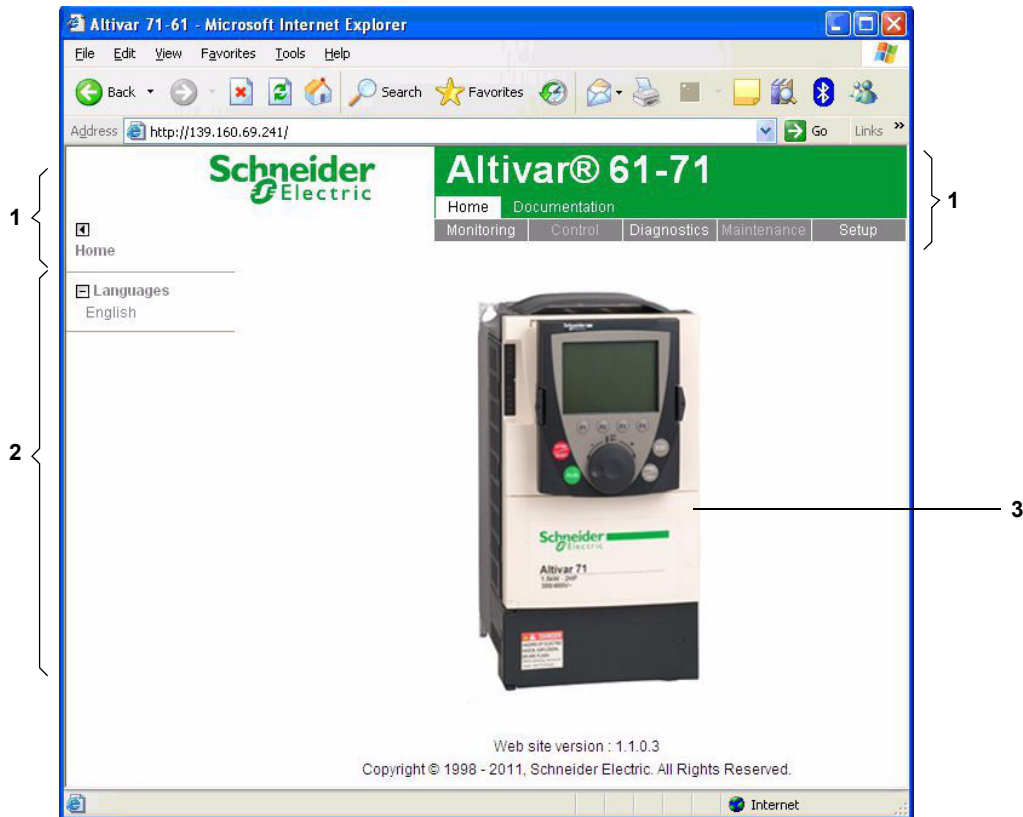

### 12. 5. "Home" menu

The home page or "Home" menu contain the following items:

- A "Languages" submenu containing:
  - A link to the "English"

The only link in the "Languages" submenu sends the user to the home page in English and configures the Web browser to open the HTML pages located in the corresponding directory (e.g., the "http://139.160.69.241/html/english/" directory becomes the standard directory in the case of English).

### 12. 6. "Monitoring" menu

The "Monitoring" menu contains the following items:

- A link to the "Drive monitor" page.
- A link to the "Drive parameters" page.
- A link to the "Drive chart" page.

## 12. Standard Web server

### ■ "Drive monitor" page

This page gives an overview of the drive state.

#### ALTIVAR

Device Name	ATV_0004
Altivar State	ACC
Device File	Local

FRH Freq. Ref.	Hz	-21.0
RFR Output Freq.	Hz	-11.1
OTR Output Torque	%	260.0
ULN Mains Voltage	V	392.1
UOP Motor voltage	V	62.0
LCR Motor Current	A	2.4
THD Drive Thermal	%	45.0
THR1 Motor Thermal	%	3.0
OPR Output Power	%	4.0
APH Power Used	kWh	-
RTH Run Time	h	40.0

L11	L17	A11	-0.0010	R1
L12	L18	A12	0.0020	R2
L13	L19	A13	0.0	R3
L14	L10	A14	0.0	R4
L15	L11	A01	0.0	LO1
L16	L12	A02	0.0	LO2
	L13	A03	0.0	LO3
	L14			LO4

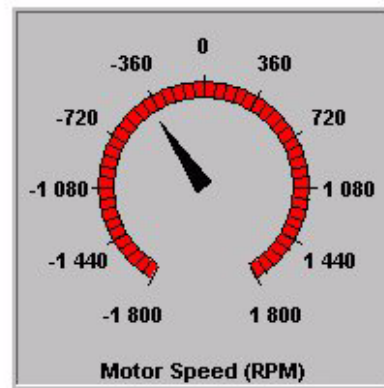

The state indicated in the "Altivar State" field corresponds to the display on the drive integrated display terminal. A delay may sometimes be noticed between the displays on the Web server and the display terminal, depending on the performance of the computer used to display the pages using a Web browser and the communication system performance.

The motor speed displayed on the "Motor Speed" gauge is calibrated according to the maximum frequency [Max frequency] ( $f_{r}$ ) and the number of pairs of poles [ $P$ ] ( $P \cdot P \cdot n$ ).

The LI... area gives the state of the drive terminals (logic inputs LI1 to LI14, logic outputs LO1 to LO4, relay outputs R1 to R4, analog inputs AI1 to AI4 and analog outputs AO1 to AO3). When a logic input is active, the LED is green. When a logic output is active, the LED is red.

## 12. Standard Web server

### ■ "Drive parameters" page

This page is used to display the drive parameters and modify their values. The parameters are arranged in groups, and consistent with the keypad and user manuals. The display mode for each value depends on the nature of the parameter.

- The unit for the physical values is displayed in the "Unit" column.
- The registers (bit fields) are displayed in hexadecimal format (16#xxxx).
- Signed values are displayed as such.

To begin the monitoring, click the "Start animation" button :

**DATA VIEWER**

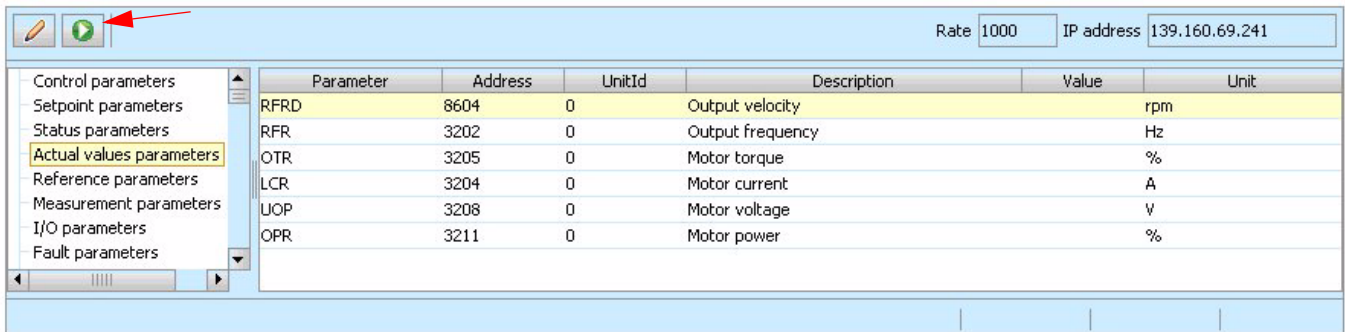

Rate: 1000 IP address: 139.160.69.241

Parameter	Address	UnitId	Description	Value	Unit
RFRD	8604	0	Output velocity		rpm
RFR	3202	0	Output frequency		Hz
OTR	3205	0	Motor torque		%
LCR	3204	0	Motor current		A
UOP	3208	0	Motor voltage		V
OPR	3211	0	Motor power		%

To modify the parameter value, click the "Write value of selected row" button then select the parameter to modify

**DATA VIEWER**

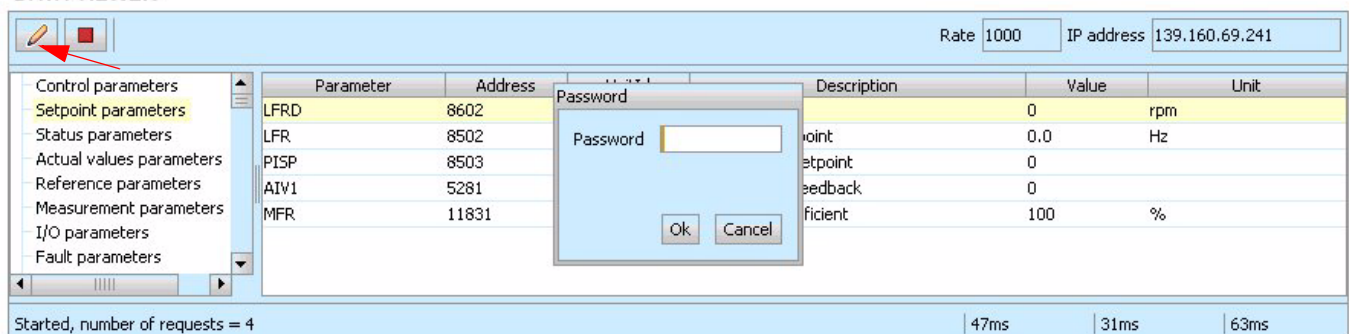

Rate: 1000 IP address: 139.160.69.241

Parameter	Address	UnitId	Description	Value	Unit
LFRD	8602	0	Output velocity		rpm
LFR	8502	0.0	Output frequency		Hz
PISP	8503	0	Feedback		
AIV1	5281	0	Efficient		%
MFR	11831	100			%

Started, number of requests = 4 | 47ms | 31ms | 63ms

It is only possible to modify the parameter values after entering the "Write password" (see "Monitor password" and "Data write password pages" section on page 45). Click on the "Password" button to enter this password. An entry field then appears in the parameter table, and also a "Cancel" button, for canceling the password entry. After entering the password, press the Enter key so that it is taken into account by the Web browser.

When the value of a parameter cannot be modified, a warning appears : "This parameter can't be written !" This is the case for all parameters until you have correctly entered the Password.

If IO Scanning has been enabled, modifying the value of a parameter assigned to periodic output variables will have no effect since this value is updated cyclically by the PLC. The same applies if a parameter is written periodically by a Modbus service.

## 12. Standard Web server

### ■“Drive Chart” page

This page is used to see how two drive parameters evolve over time.

#### ALTIVAR CHART

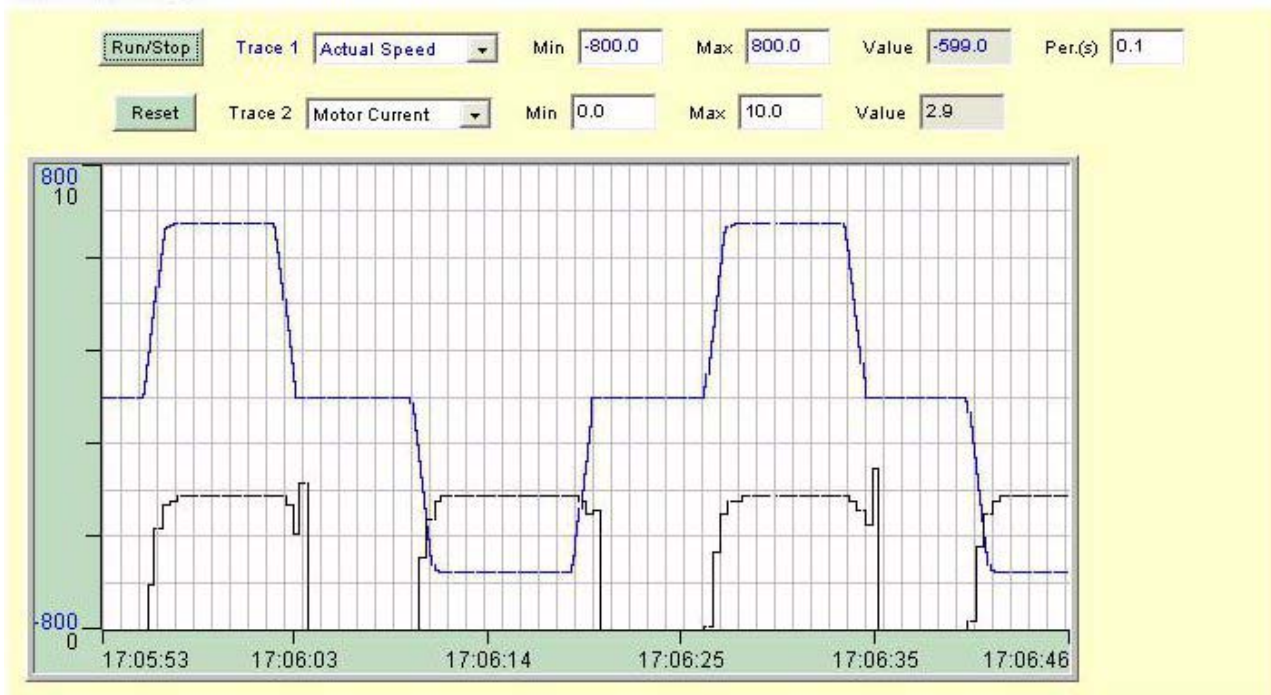

Two parameters can be selected and displayed simultaneously. To do this, select them in the **Trace1** and **Trace2** list.

To define the display range better, you can modify the curve min and max points by entering the values directly in the fields: **Min** and **Max** of each trace.

In order to speed up sampling, it is possible to put the value 0 in the **Intv(s)** entry field.

**Note:** Entering the value 0 increases the traffic on the Ethernet network and can cause collision problems if there is too much traffic, thereby reducing the overall network performance. The sampling period can be increased.

To start the oscilloscope function, press the **Run/Stop** button. Pressing the button again halts sampling and updates the screen.

**Reset:** clears the active traces.

## 12. Standard Web Server

### 12. 7. Diagnostics

The “Diagnostics” menu contains the following item:

- A link to the “Ethernet” page.
- A link to the “Modbus TCP” page.
- A link to the “EtherNET/IP” page.
- A link to the “RSTP port” page.
- A link to the “RSTP bridge” page.

#### ■“Ethernet” page

This page provides the Ethernet statistics.

<b>TCP/IP parameters</b>		<b>Status</b>	
IP address	192.168.0.2	Link status (left/A port)	100MBit/s - FD
Subnet mask	255.255.255.0	Link status (right/B port)	Not connected
Default gateway	0.0.0.0	<b>Receive statistics</b>	
IP mode	Fixed	Frame received OK	362
<b>Ethernet parameters</b>		CRC errors	0
MAC address	00-80-f4-7d-00-12	<b>Transmit statistics</b>	
Ethernet frame format	Ethernet II	Frame transmitted OK	360
Data rate (left/A port)	Auto	Collisions	0
Data rate (right/B port)	Auto	Carrier sens errors	0
		Excessive collisions	0
		Late collisions	0
		Reset counters	

#### ■“Modbus TCP” page

Reserved for Modbus parameters. See ATV61/71 ModbusTCP manual HRB10064 to the website [www.schneider-electric.com](http://www.schneider-electric.com)

## 12. Standard Web server

### ■“EtherNET/IP” page

Connection diagnostic		Explicit messaging diagnostic	
Max CIP IO connections opened	0	Class3 msg send counter	0
Current CIP IO connections	0	Class3 msg receive counter	0
Max CIP Exp connections opened	0	UCMM msg send counter	0
Current CIP Exp connections	0	UCMM msg receive counter	0
CIP connection opening errors	0	<b>Bandwidth diagnostic</b>	
CIP connection timeout errors	0	Current sending urgent prio rate (pkt/s)	0
Max EIP TCP connections opened	0	Current reception urgent prio rate (pkt/s)	0
Curent EIP TCP connections	0	Current sending scheduled prio rate (pkt/s)	0
<b>IO messaging diagnostic</b>		Current reception scheduled prio rate (pkt/s)	0
IO production counter	0	Current sending high prio rate (pkt/s)	0
IO consumption counter	0	Current reception high prio rate (pkt/s)	0
IO production send error counter	0	Current sending low prio rate (pkt/s)	0
IO consumption receive error counter	0	Current reception low prio rate (pkt/s)	0
<a href="#">Reset counters</a>		Current sending explicit rate (pkt/s)	0
		Current reception explicit rate (pkt/s)	0

### ■“RSTP port” page

Port LEFT		Port RIGHT	
Status	Forwarding	Status	Discarding
Role	Designated	Role	Disabled
Priority	128	Priority	128
Port Path Cost	200000	Port Path Cost	2000000
Designated Port ID	0x8000	Designated Port ID	0x8001
Receive RSTs	0	Receive RSTs	0
Transmitted RSTs	93	Transmitted RSTs	1
Receive Configure	0	Receive Configure	0
Transmit Configure	0	Transmit Configure	0
Receive TCNs	0	Receive TCNs	0
Transmit TCNs	0	Transmit TCNs	0
<a href="#">Reset Counter</a>			

## 12. Standard Web server

---

### ■“RSTP bridge” page

General	
Bridge Status	Enabled
Bridge ID	0x8000
Designated Root ID	0x8000.00-80-f4-7d-00-12
Designated Root Port	na
RootPath Cost	0
Total Topology Changes	0

Configured vs Learned	
Configured Hello Time	2
Learned Hello Time	2
Configured Forward Delay	21
Learned Forward Delay	21
Configured Max Age	36
Learned Max Age	36

## 12. Standard Web server

---

### 12. 8. "Setup" menu

The "Setup" menu contains the following items:

- A link to the "Network & protocol" page
- A link to the "RSTP" page.
- A link to the "Modbus TCP scanner" page.
- A link to the "EtherNET/IP scanner" page.
- A link to the "FDR Agent" page.
- A link to the "Email" page.
- A "Security" submenu containing:
  - A link to the "Monitor password" page.
  - A link to the "Data write password" page.
  - A link to the "Administrator Password" page.

#### ■ "Network & protocol" page

Network setting		EtherNET/IP	
Protocol	<input type="text"/>	Configured assemblies	<input type="text" value="Not configured"/>
Left/A port	<input type="text" value="Autodetect"/>		
Right/B port	<input type="text" value="Autodetect"/>		
IP mode	<input type="text" value="Fixed"/>		
IP address	<input type="text" value="192.168.0.2"/>		
Subnet mask	<input type="text" value="255.255.255.0"/>		
Gateway address	<input type="text" value="0.0.0.0"/>		
Device Name	<input type="text"/>		

## 12. Standard Web server

### ■“RSTP” page

#### Bridge parameters

Bridge Parameters	
Status	Enabled
Bridge Priority	0x8000
Hello Time (s)	2
Max Age Time (6-40s)	36
Transmit Count (3-100)	40
Forward Delay (4-30s)	21

#### Status

Logic address	Supported values
60700	0 (disabled)
	1 (Enabled)

Enable the use of Rapid Spanning-Tree Protocol

#### Bridge priority

Logic address	Supported values
60701	0
	4096
	8192
	12288
	16384
	20480
	24576
	28672
	32768
	36864
	40960
	45056
	49152
	53248
	57344
	61440

The bridge priority is used to control which bridge is elected as the root bridge.

Bridge with the smallest (lowest) bridge ID is elected as the root bridge. Bridge ID consists of the configurable priority and the MAC address of the bridge. To compare two bridge IDs, the priority is compared first. If the bridge priorities are equal, then the MAC addresses are compared.

The bridge priority can be set only in increments of 4096.

#### Hello time

Logic address	Supported values
60702	1 to 10 seconds

The hello time parameter corresponds to the time interval at which the root bridge transmits configuration Bridge Protocol Data Units (BPDU)s.

## 12. Standard Web server

---

### ■“RSTP” page (continued)

#### RSTP Bridge Max Age Time

Logic adress	Supported values
60703	6 to 40 seconds

The maximum age time correspond to the maximum expected arrival time of hello BPDUs. If the timer expires, the bridge detects a communication interruption to the root bridge and initiates a topology convergence.

The maximum age timer should be longer than the configured Hello Timer.

#### Transmit Count

Logic adress	Supported values
60704	3 to 100

It defines the maximum number of BPDUs the system can transmit on a port within the Hello Time interval.

#### Forward delay

Logic adress	Supported values
60705	4 to 30 seconds

The forward delay time corresponds to the amount of time an STP bridge port remains in the listening and learning states before transitioning to the forwarding state.

In case of a too short interval, unnecessary spanning-tree convergences may occur.

#### Ports parameters

**Ports Parameters**

Port Left Priority: 128

Port Left Path Cost: 0

Port Right Priority: 128

Port Right Path Cost: 0

Apply Undo

PassWord

#### Port Left Priority

Logic adress	Supported values
60724	0 to 240 (in step of 16)

This defines the priority of the interface compare to other going to the same subnet. The left port priority can be set only in increments of 16.

The value will be taken into account by the drive after power off and on the drive.

## 12. Standard Web server

---

### ■“RSTP” page (continued)

#### Port Left Path Cost

Logic adress	Supported values
60725	0 (Auto) to 200,000,000

The path cost corresponds to the cost of sending spanning tree traffic through the interface. It is used by RSTP to determine the topology with the smallest total path cost between each point of the tree and the root bridge

If set to **0 (Auto)**: the path cost is based on the port link maximum speed as defined in the table below

Port link maximum speed	Automatic Path Cost
10 Gb/s (Not supported by the card)	2,000
1 Gb/S (Not supported by the card)	20,000
100 Mb/s	200,000
10 Mb/s	2,000,000

#### Port Right Priority

Logic adress	Supported values
60738	0 to 240 (in step of 16)

This defines the priority of the interface compare to other going to the same subnet. The Right port priority can be set only in increments of 16.

The value will be taken into account by the drive after power off and on the drive.

#### Port Right Path Cost

Logic adress	Supported values
60739	0 (Auto) to 200,000,000

The path cost corresponds to the cost of sending spanning tree traffic through the interface. It is used by RSTP to determine the topology with the smallest total path cost between each point of the tree and the root bridge

If set to **0 (Auto)**: the path cost is based on the port link maximum speed as defined in the table below

Port link maximum speed	Automatic Path Cost
10 Gb/s (Not supported by the card)	2,000
1 Gb/S (Not supported by the card)	20,000
100 Mb/s	200,000
10 Mb/s	2,000,000

## 12. Standard Web server

### ■“Modbus TCP scanner” page

See ATV61/71 ModbusTCP manual HRB10064 to the website [www.schneider-electric.com](http://www.schneider-electric.com)

### ■“EtherNET/IP scanner” page

EtherNet/IP scanner setup

Drive input parameters			Drive output parameters				
	Parameter	Config.	Description		Parameter	Config.	Description
<input checked="" type="checkbox"/>	CW	-	Control word	<input checked="" type="checkbox"/>	SW	-	Status word
	VP	-	Velocity point		VF	-	Velocity feedback
<input checked="" type="checkbox"/>	NCA1	CMD	Control word	<input checked="" type="checkbox"/>	NMA1	ETA	Status word
	NCA2	LFRD	Speed setpoint		NMA2	RFRD	Output velocity
<input checked="" type="checkbox"/>	NCA3	-0-	Not Assigned	<input checked="" type="checkbox"/>	NMA3	-0-	Not Assigned
	NCA4	-0-	Not Assigned		NMA4	-0-	Not Assigned
<input checked="" type="checkbox"/>	NCA5	-0-	Not Assigned	<input checked="" type="checkbox"/>	NMA5	-0-	Not Assigned
	NCA6	-0-	Not Assigned		NMA6	-0-	Not Assigned
<input checked="" type="checkbox"/>	NCA7	-0-	Not Assigned	<input checked="" type="checkbox"/>	NMA7	-0-	Not Assigned
	NCA8	-0-	Not Assigned		NMA8	-0-	Not Assigned

Setpoint unit

All modifications are protected by the “Write password” modification password. Click on the “PassWord” button to enter the “Write password”. After correctly entering the password, you can access “IoScanner”, “Setpoint unit”, “Output parameters”, “Input parameters” and the “Save” and “Abort” buttons.

By default, the password is “USER”. It can be modified in the “Data write password” page.

### ■“FDR Agent” page

Reserved for Modbus parameters. (See ATV61/71 ModbusTCP manual HRB10064)12.

# 11. Standard Web server

## ■ "Email" page

The configuration page of the Email service is available in the setup menu → Email of the option board web page.

This service is able to generate and send emails to a predefined address in case of alarm warning or drive fault. The controller inside option board can also initiate the sending of an email.

IP Address	192.168.0.2	Email Status	Idle	Send Counter	0
Device Name		Email Error	0	Error Counter	0

<b>Activation</b>		Email IP Server	Not defined	Reset Counter
Drive Fault	<input type="checkbox"/>	Email dest. @		
Eth. board Fault	<input type="checkbox"/>	Email from @		
Drive Alarm	<input type="checkbox"/>			
PLC board msg	<input type="checkbox"/>			

It is possible to configure the Email service after entering the "Write password" (see "Monitoring password" and "Data write password pages" section on page 45).

Enter the following information to configure the Email service :

**Email IP Server** : IP address of the Email server that will process the message (SMTP server)

**Email Dest @** : Email address of the Email recipient

**Email From @** : Email address of the Ethernet option board which will send the email (this is a virtual address since the option board does not provide any incoming email box)

Configure the triggering mode for sending Email :

**Drive Fault** : an Email is sent on a drive fault (triggered by ETA.3)

**Drive alarm** : an Email is sent on a drive warning (triggered by ETA.7)

**Eth. Board fault** : an Email is sent on an ethernet board fault

**PLC Board status** : an Email is sent on demand from the application of the controller inside board

Email example sent on CNF fault of the Ethernet board :

```
From: ALTIVAR@schneider-electric.fr
Subject: Error CNF on Altivar Drive
Date: 22 Dec 2012 14:55:32 +0100

Fault occured on Ethernet Board's Drive:
DeviceName: ATV
IP Address: 192.168.0.2
Reference : ATV71H037M3

Description:
LFR Register = XX
TimeOut TCP/Modbus (CNF)

IMPORTANT NOTICE
This Email has been automatically generated. Please do not reply.
Copyright © 2011, Schneider Electric. All rights reserved
```

Service diagnostic :

- Email Status
  - 0 → Idle
  - 1 → Operational
  - 2 → Stopped
- SentCount : number of emails successfully sent
- ErrorCount : number of errors occurred
- LastError : last error code

## 12. Standard Web server

---

### 12.9. "Security" Submenu

The "Security" submenu contains the following items:

- A "Security" submenu containing:
  - A link to the "Monitor password" page.
  - A link to the "Data write password" page.
  - A link to the "Administrator Password" page.

#### ■ "Monitor password" and "Data write password pages"

These two pages are used to modify the two Web server passwords.

By default, the user name and both passwords are: "USER" (upper case).

The Monitor security password is the basic level access to the drive through the webserver: it allows the access to the different web pages but don't authorize write access.

New level username and password can be redefined here.

When the value of a parameter cannot be modified, the background of the corresponding cell appears grayed-out. This is the case for all parameters until you have correctly entered the "Write password".

The image shows two separate web forms. The first form is for changing the password and contains three input fields: 'Username:', 'New password:', and 'Confirm password:'. Below these fields is a button labeled 'Change password'. The second form is for changing the username and contains three input fields: 'Username:', 'New username:', and 'Confirm username:'. Below these fields is a button labeled 'Change username'.

The image shows a web form for changing the Data Editor Write password. It contains three input fields: 'Data Editor Write password:', 'New write password:', and 'Confirm write password:'. Below these fields is a button labeled 'Change setup password'.

**Note:** Do not lose the user name or the passwords. If they are lost, the Web server can no longer be used, and the card has to be sent for repair.

## 12. Standard Web server

---

### 12. 10. “Documentation” menu

The “Documentation” menu contains a link to the “References” page.  
This page displays a link to the site: <http://www.schneider-electric.com/>.

# 13. Integration in RSLogix

## 13.1. Principle

RSX drive equipped with an EtherNet/IP card shall be configured as a "Generic Ethernet Module" in the same way as the EtherNet/IP adapter of PowerFlex 70 drives.

## 13.2. Procedure

### ■ Create a new project

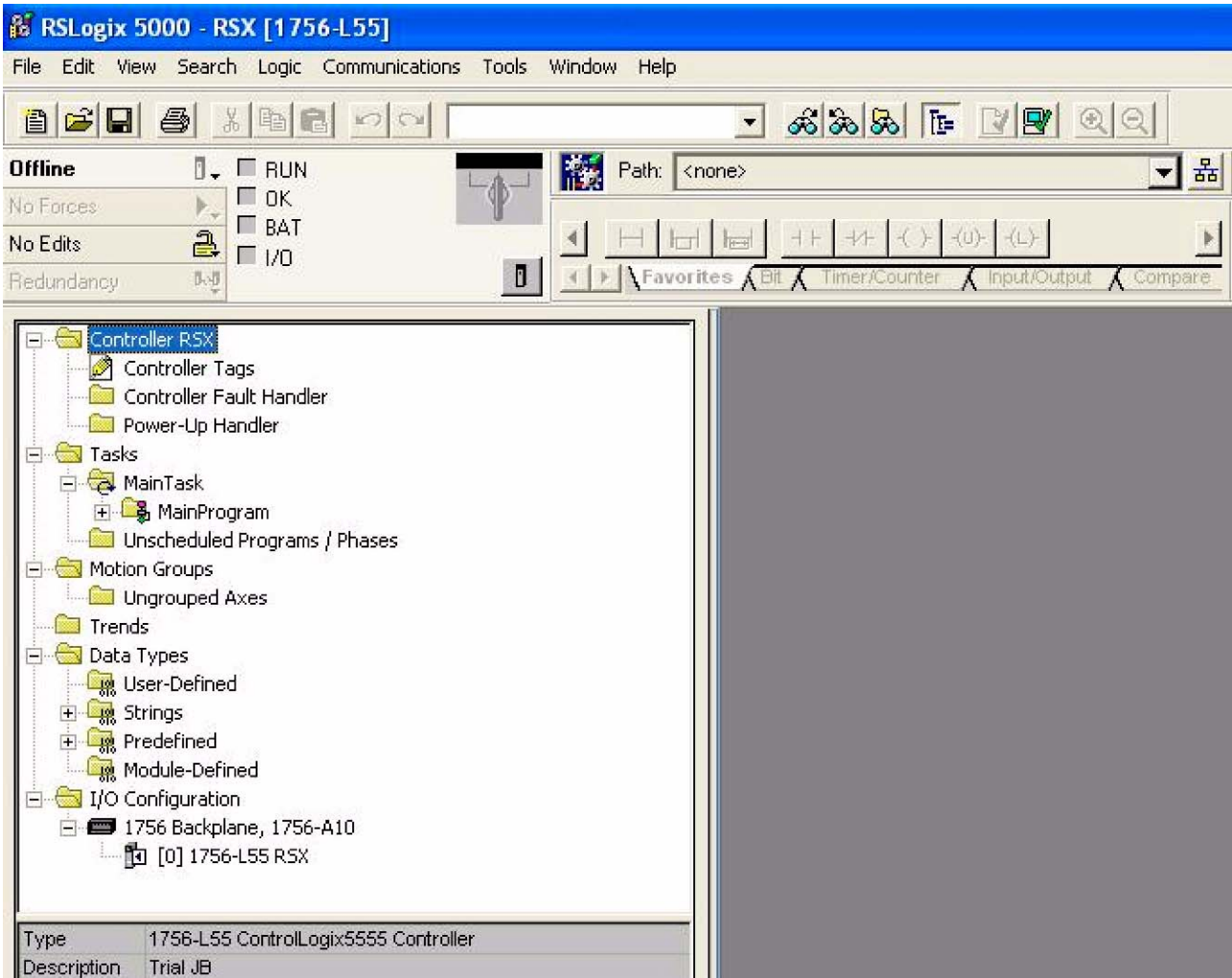

# 13. Integration in RSLogix

## ■ Add a EtherNet/IP scanner to the I/O configuration

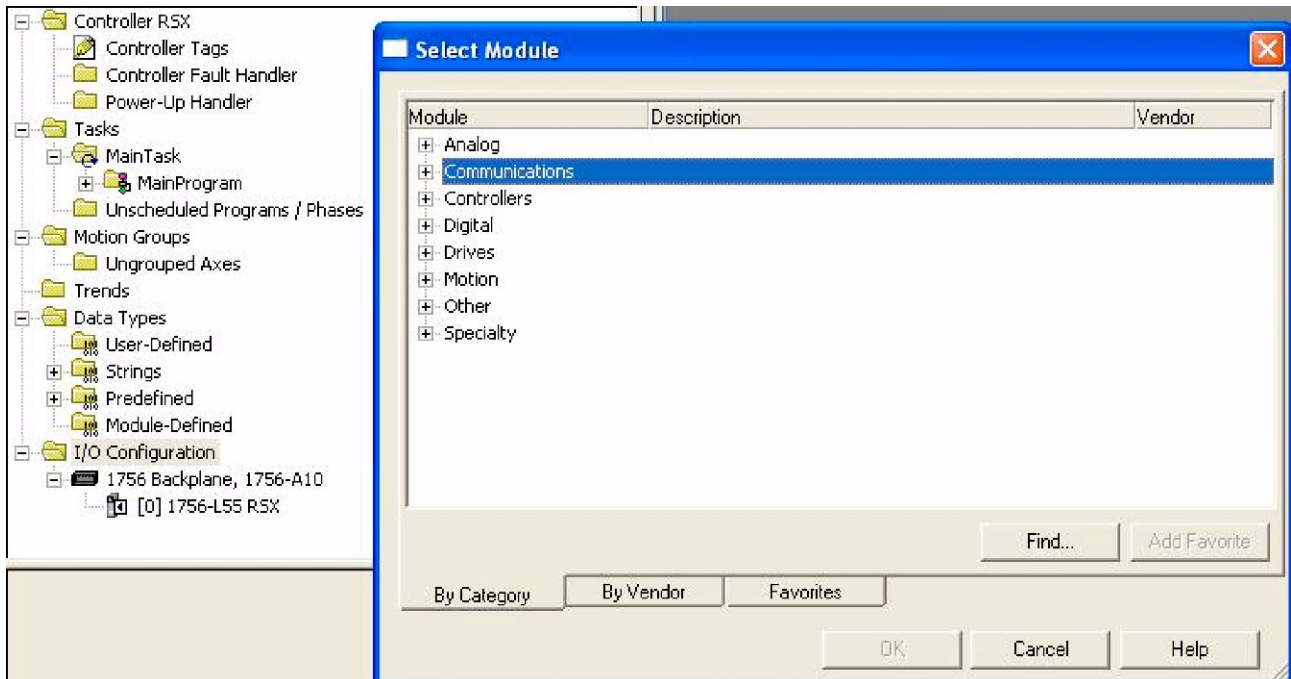
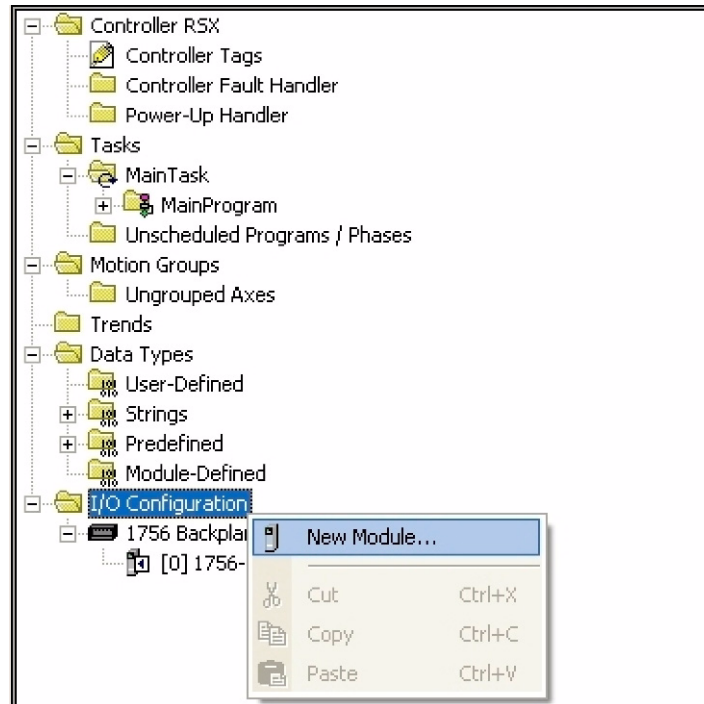

## 13. Integration in RSLogix

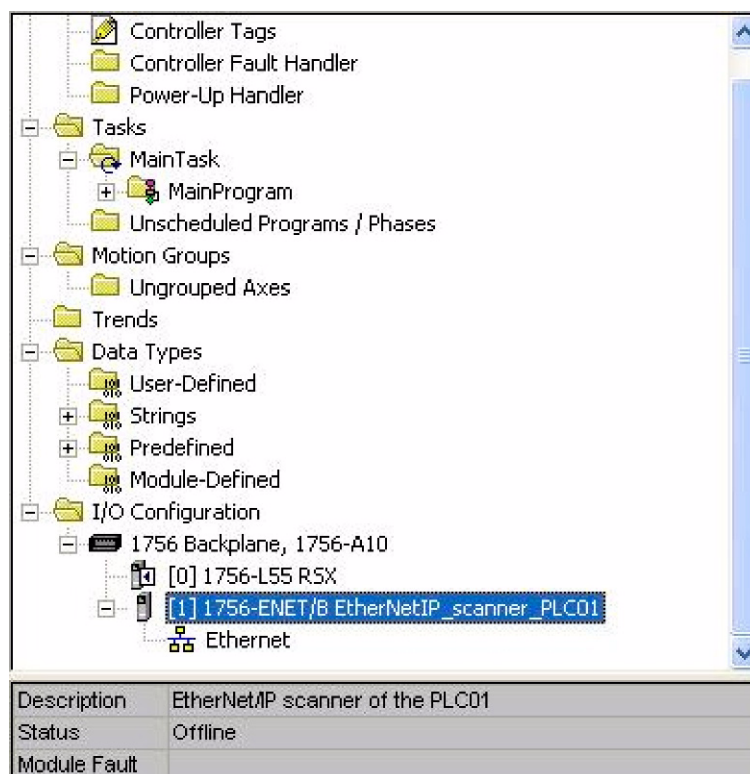
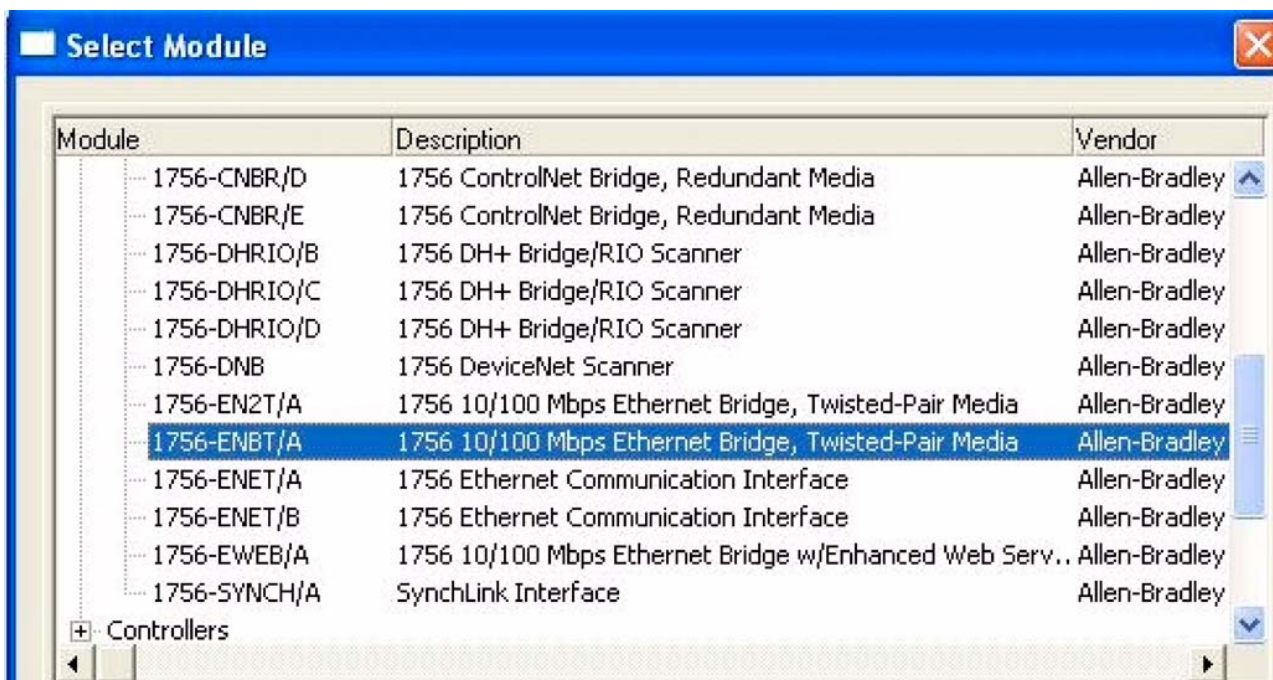

# 13. Integration in RSLogix

## ■ Configure the EtherNet/IP scanner

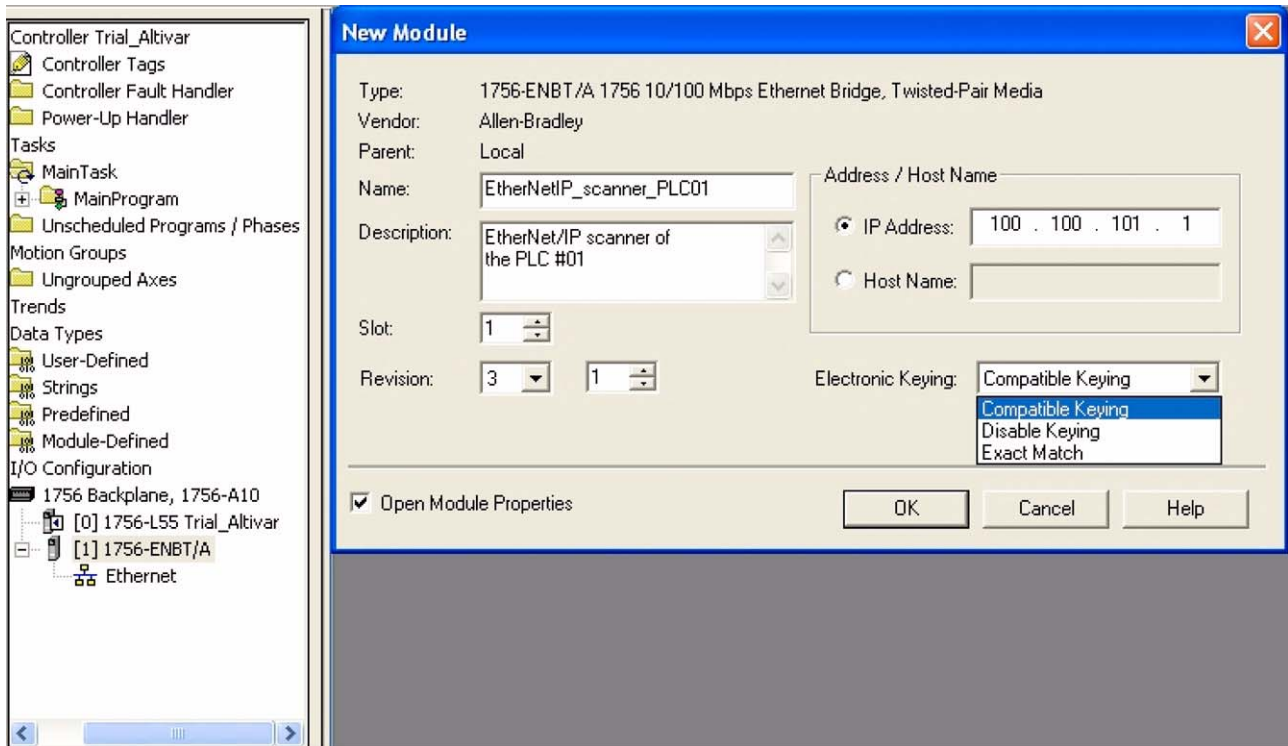

## ■ Add a EtherNet/IP ATV61/71 drive to the I/O configuration

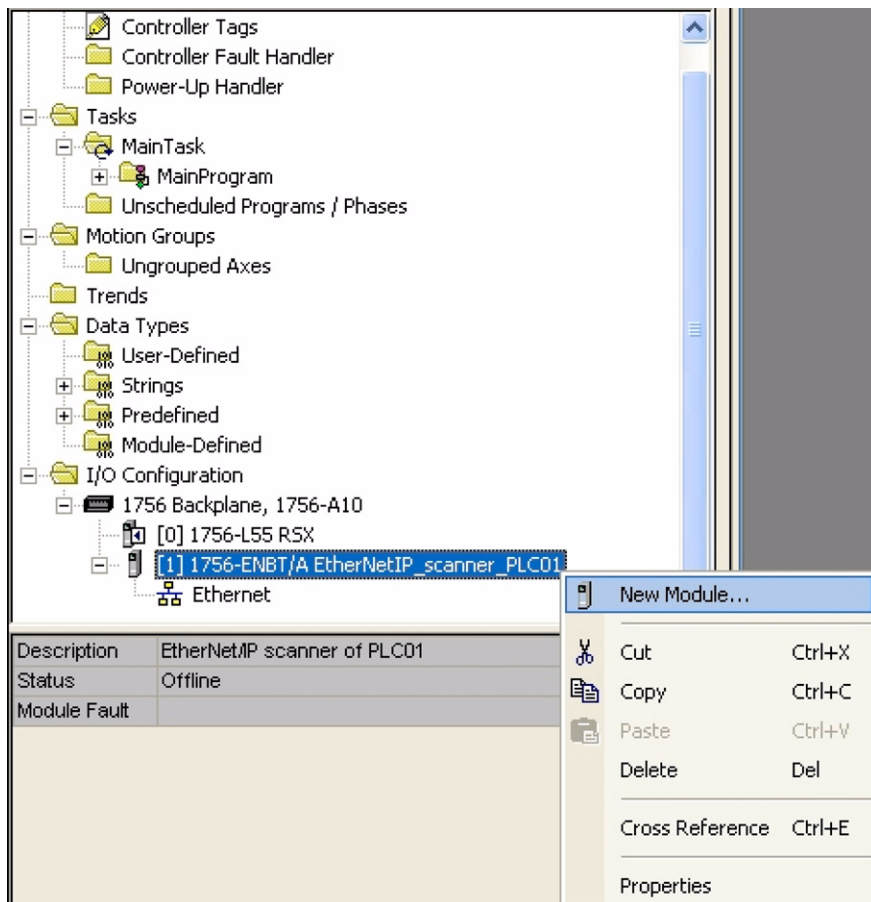

# 13. Integration in RSLogix

Description	EtherNet/IP scanner of PLC01
Status	Offline
Module Fault	

Module	Description	Vendor
+	Communications	
+	Drives	
+	HMI	

Description	EtherNet/IP scanner of PLC01
Status	Offline
Module Fault	

Module	Description	Vendor
1769-L32E Etherne..	10/100 Mbps Ethernet Port on CompactLogix5332E	Allen-Bradley
1769-L35E Etherne..	10/100 Mbps Ethernet Port on CompactLogix5335E	Allen-Bradley
1788-EN2DN/A	1788 Ethernet to DeviceNet Linking Device	Allen-Bradley
1788-ENBT/A	1788 10/100 Mbps Ethernet Bridge, Twisted-Pair Media	Allen-Bradley
1788-EWEB/A	1788 10/100 Mbps Ethernet Bridge w/Enhanced Web Serv..	Allen-Bradley
1794-AENT/A	1794 10/100 Mbps Ethernet Adapter, Twisted-Pair Media	Allen-Bradley
Drivelogix5730 Eth...	10/100 Mbps Ethernet Port on DriveLogix5730	Allen-Bradley
ETHERNET-BRIDGE	Generic EtherNet/IP CIP Bridge	Allen-Bradley
ETHERNET-MODULE	Generic Ethernet Module	Allen-Bradley
EtherNet/IP	SoftLogix5800 EtherNet/IP	Allen-Bradley
PH-P55CENA/A	Ethernet Adapter, Twisted-Pair Media	Parker Hannif
+	Drives	
+	HMI	

## 13. Integration in RSLogix

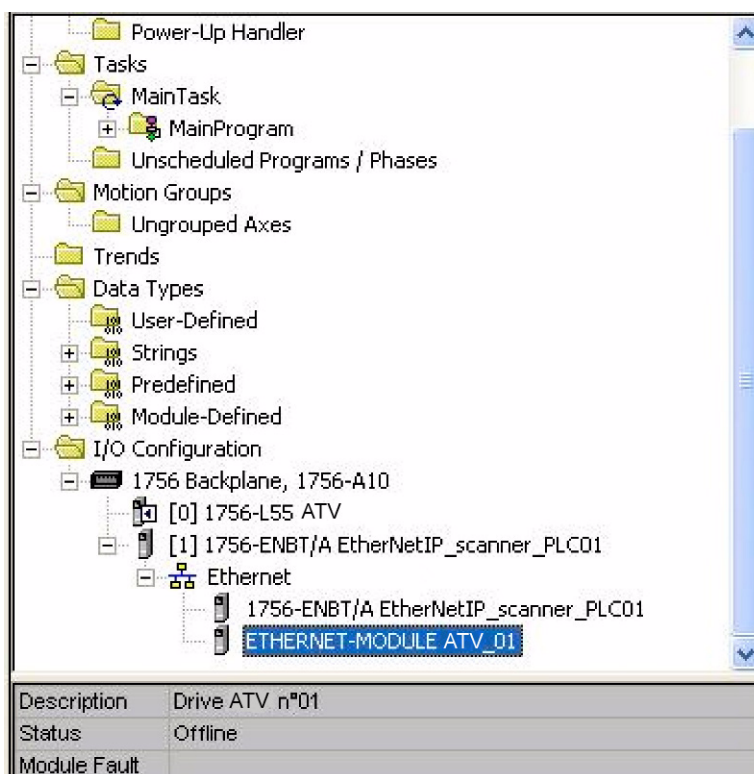

### ■ Configure the ATV61/71 EtherNet/IP card

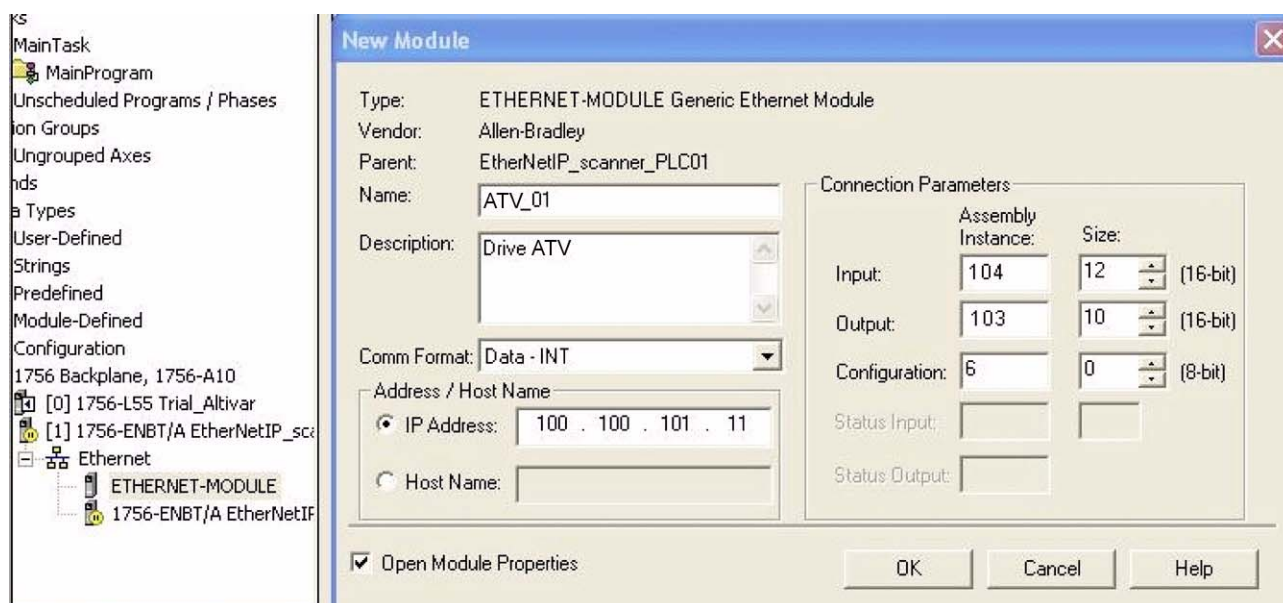

Above the Allen-Bradley drive profile is selected.

# 13. Integration in RSLogix

Below the CIP extended speed control profile is selected.

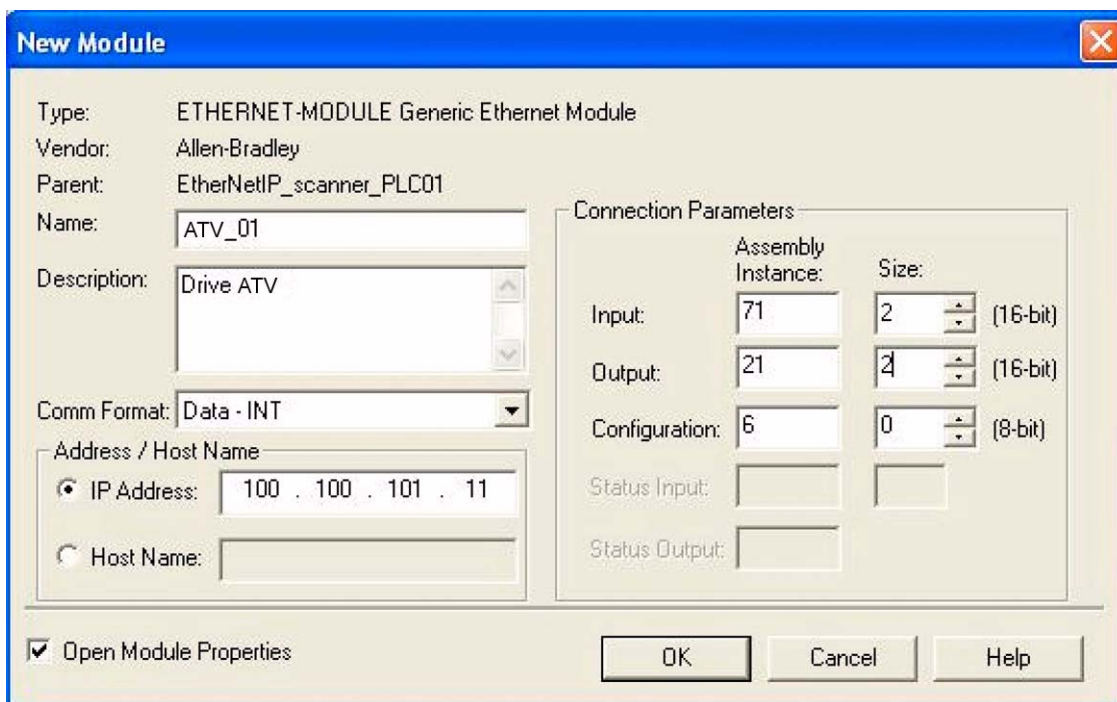

Below the CIP extended speed and torque control profile is selected.

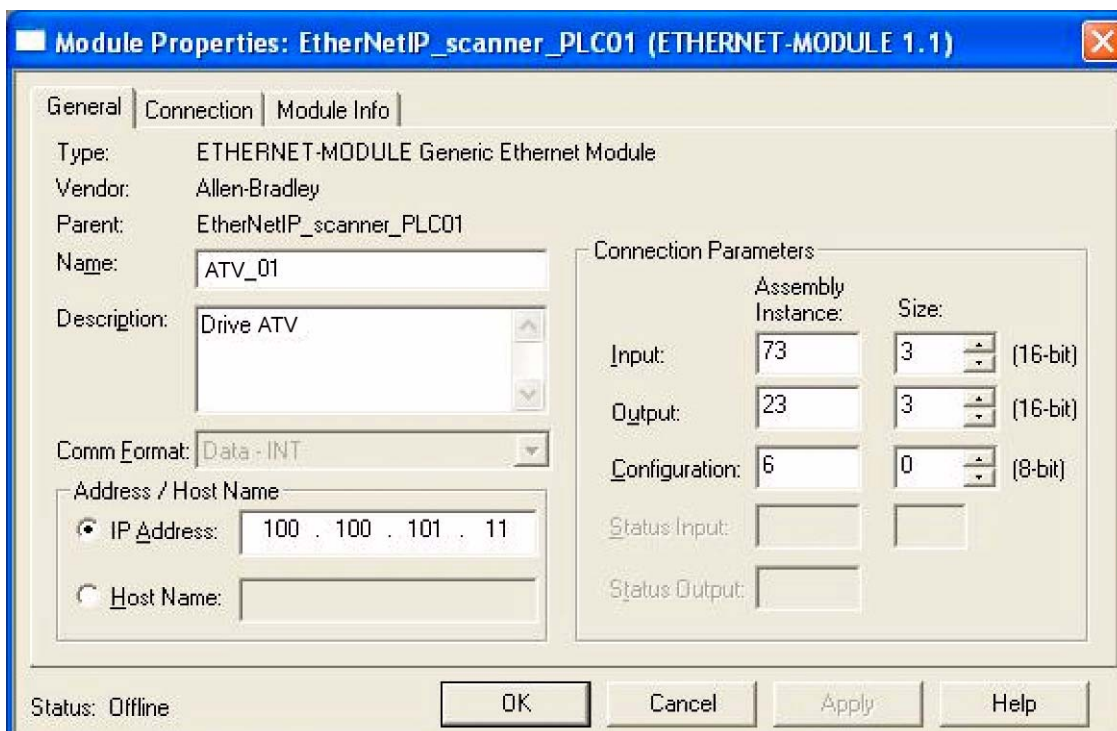

# 13. Integration in RSLogix

Below native RSX profile is selected.

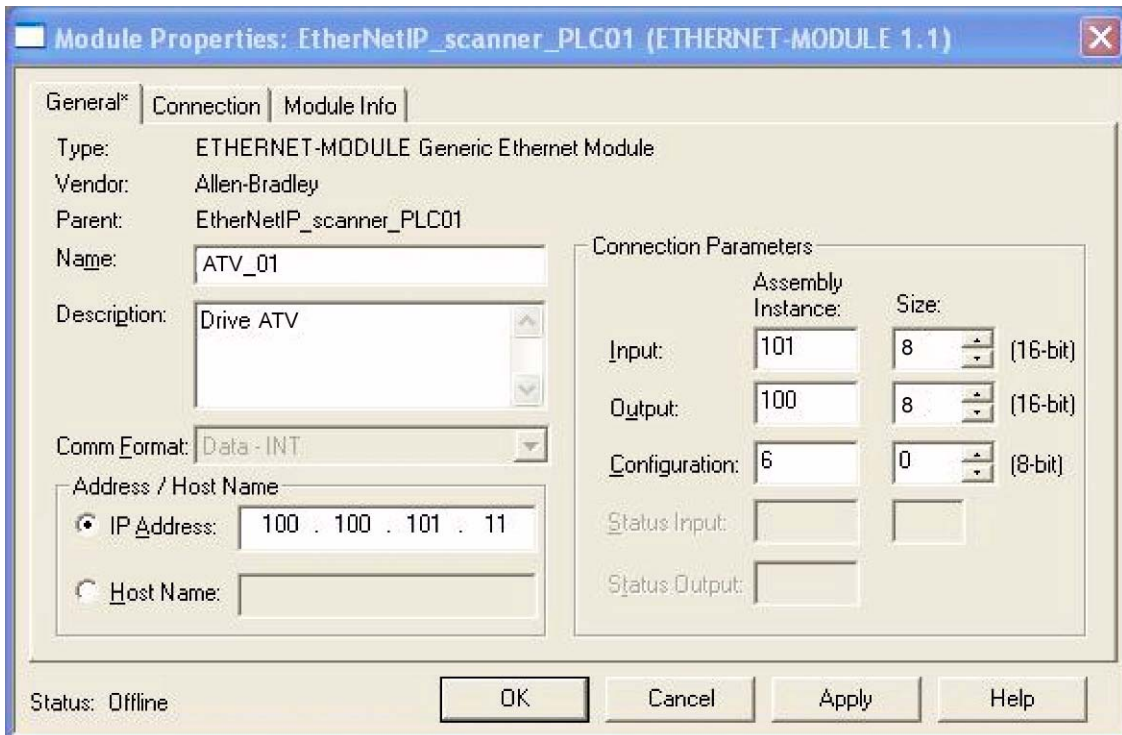

## 13. 3. Registering the EDS file in RSLogix

An EDS file is provided with the drive. (This file is available on the CD or on [www.schneider-electric.com](http://www.schneider-electric.com)). It exists 1 EDS file for the ATV71 and 1 EDS file for the ATV61. The following lines describe how to import these files in your project:

In RSnetWorx , start the EDS wizards

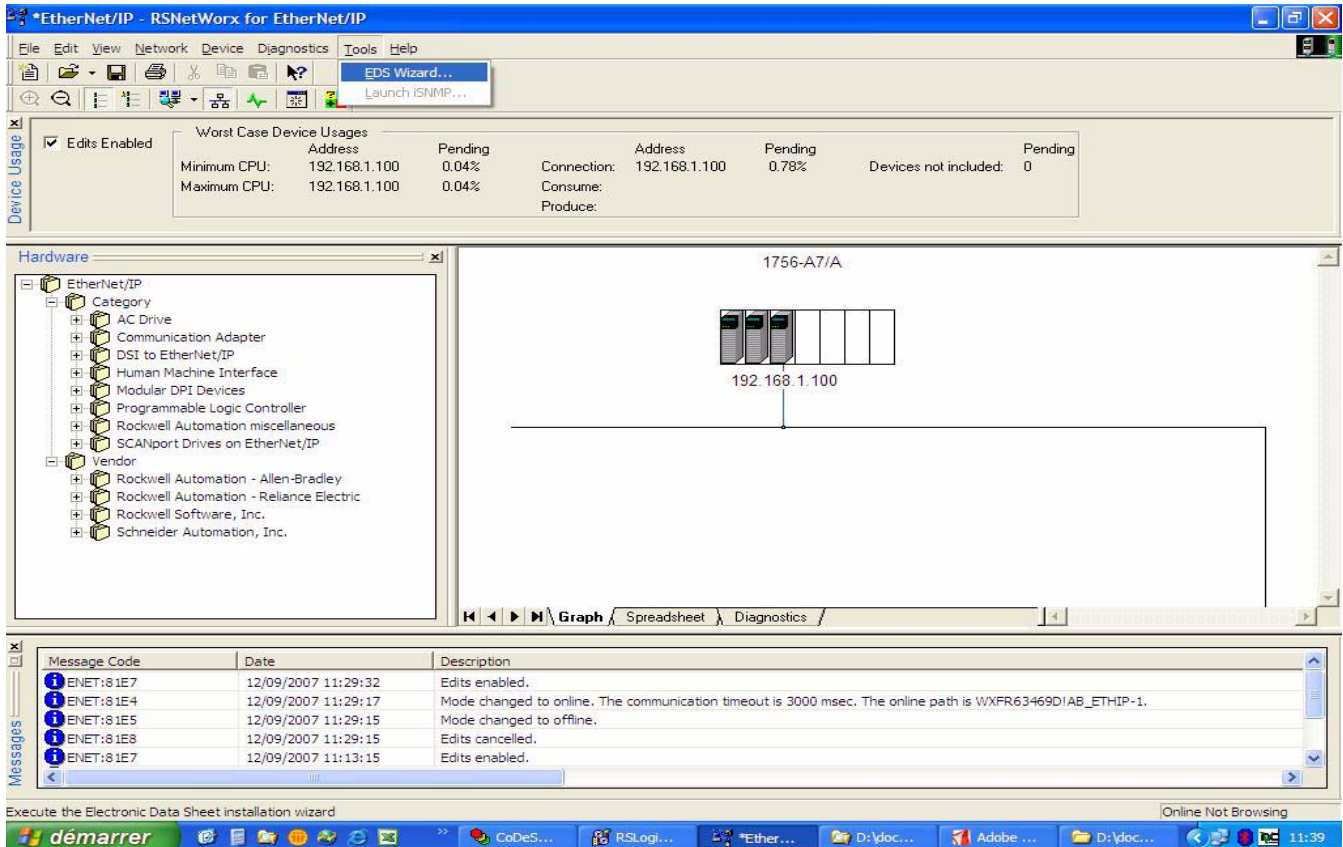

# 13. Integration in RSLogix

Follow the instructions:



Choose "Register" to import a new EDS file.  
If you want to update an EDS file you need to "unregister" this device first.



# 13. Integration in RSLogix

Select the required file:

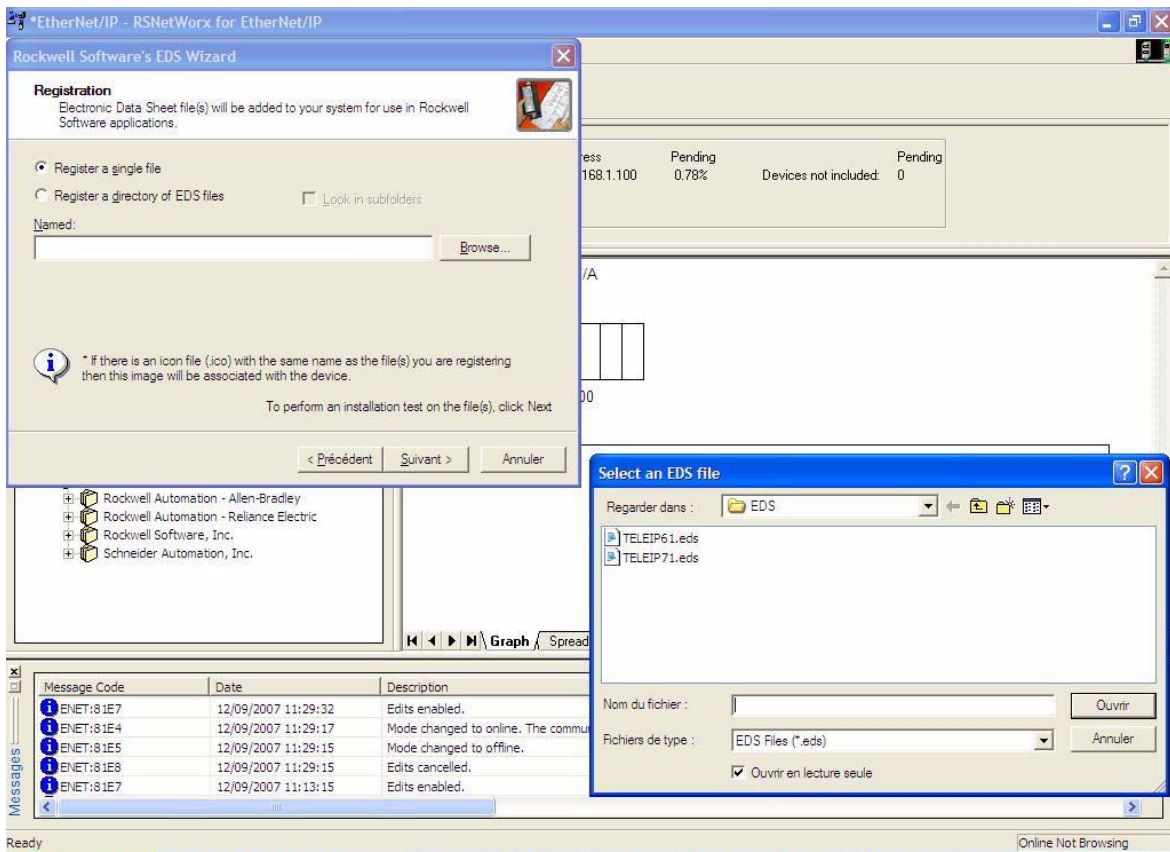

Then finish, the dialog box displays the result of the import operation.

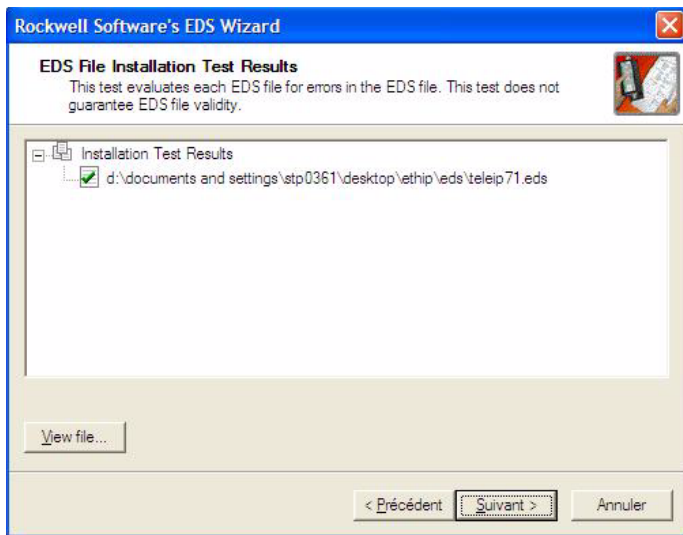

# 14. CIP objects

## 14. 1. Supported object classes

Three categories of object classes can be defined:

- 1: CIP device on EtherNet/IP.
- 2: AC/DC drive.
- 3: VSD specific.

These objects are detailed here:

Object class	Class ID	Cat.	Number of instances	Effect on behavior Interface
<a href="#">Identity object (14. 2.) page 57</a>	16#01	1	1	Supports the reset service
<a href="#">Message router object (14. 3.) page 61</a>	16#02	1	1	Explicit message connection
<a href="#">Ethernet Link object (14. 4.) page 63</a>	16#F6	1	1	Counter and status information
<a href="#">TCP/IP Interface object (14. 5.) page 66</a>	16#F5	1	1	TCP/IP configuration
<a href="#">Connection object manager (14. 6.) page 68</a>	16#05	1	1	
<a href="#">Motor data object (14. 7.) page 69</a>	16#28	2	1	Defines data for the motor connected to the device
<a href="#">Control supervisor object (14. 8.) page 70</a>	16#29	2	1	Manages drive functions, operational states and control
<a href="#">AC/DC Drive Object (14. 9.) page 72</a>	16#2A	2	1	Provides drive configuration
<a href="#">Assembly object (14. 10.) page 73</a>	16#04	2	12	Defines I/O data format
<a href="#">Application objects (14. 11.) page 74</a>		3	1	Vendor specific - drive's parameters

## 14. 2. Identity object

The Identity object provides identification and status information about the drive.

### Class code

Hexadecimal	Decimal
16#01	1

### Class attributes

Attribute ID	Access	Name	Data type	Value	Details
1	Get	Revision	UINT	1	-
2	Get	Max Instances	UINT	1	1 defined instance
3	Get	Number of Instances	UINT		-
4	Get	Optional attribute list	UINT	1	-
6	Get	Max ID of class attributes	UINT	7	-
7	Get	Max ID of instance attribute	UINT	17	-

## 14. CIP objects

### Instance attributes

Attribute ID	Access	Name	Need	Data type	Value	Details
1	Get	Vendor ID	Req.	UINT	243	Schneider Automation, Inc [243]
2	Get	Device type	Req.	UINT	16#02	AC/DC drive profile
3	Get	Product code	Req.	UINT	5 or 7	5: ATV71 7: ATV61
4	Get	Revision	Req.	Struct of: USINT USINT	—	Product revision of the drive (1)
5	Get	Status	Req.	WORD	—	See definition in the table below (Attribute 5-Status)
6	Get	Serial number	Req.	UDINT	—	Serial number of the drive
7	Get	Product name	Req.	Struct of: USINT STRING	—	11 (product name length) "ATV71 Drive"
8	Get	State	Opt.	USINT	—	0: Non existent 1: Device self-testing 2: Standby 3: Operational 4: Major recoverable fault 5: Major unrecoverable fault
10	Get/Set	Heartbeat interval (2)	Opt.	USINT	0–255	Interval in seconds between two heartbeat messages. 0: No message.

(1) Mapped in a word: MSB minor revision (second USINT), LSB major revision (first USINT).

Example: 517 = 16#0205 means revision V5.2.

(2) The heartbeat message broadcasts the current state of the device.

### Attribute 5-Status

Bit	Definition	How
0	Owned by Master (predefined Master/Slave Connection)	No interface
2	Configured	If any of the product (option + drive) NVS attributes has changed from their default (out of box values) <b>NOTE:</b> Network comm attributes are not included here.
4-7	Extended device status: See table (Bit4-7 Defenition) page 59	-
8	Minor Recoverable Fault	No minor rec. fault
9	Minor Unrecoverable Fault	No minor unrec. fault
10	Major Recoverable Fault	<i>C n F</i> detected error or CIP connection timeout or Eth network overload
11	Major Unrecoverable Fault	<i>I L F</i> detected fault, eeprom failed, OB hardware detected error
Others	Reserved 0	-

## 14. CIP objects

---

### Bit 4-7 Definition

Bit 4-7	Definition	How
0 0 0 0	Self testing or unknown	Not used
0 0 0 1	Firmware update in progress	Not used
0 0 1 0	At least on faulted I/O connection	-
0 0 1 1	No I/O connections established	-
0 1 0 0	Non-volatile configuration bad	Non volatile memory detected error in OB
0 1 0 1	Major fault - either bit 10 or 11 is true	Bit 10 or 11 is true
0 1 1 0	At least one I/O connection in run mode	-
0 1 1 1	At least one I/O connection established, all in idle mode	-
1 0 0 0 1 0 0 1	Reserved, shall be 0	-
1 0 1 0 to 1 1 1 1	Vendor specific	-

### Supported Class Services

Service code	Service Name	Description
01 hex	Get_Attribute_All	Read all attributes
0E hex	Get_Attribute_Single	Read one attributes

### Supported Instance Services

Service code	Service Name	Description
01 hex	Get_Attribute_All	Read all attributes
0E hex	Get_Attribute_Single	Read one attributes
10 hex	Set_Attribute_Single	Write one attribute
05 hex	Reset	Perform the reset of the drive

# 14. CIP objects

State Diagram for the Identity Object

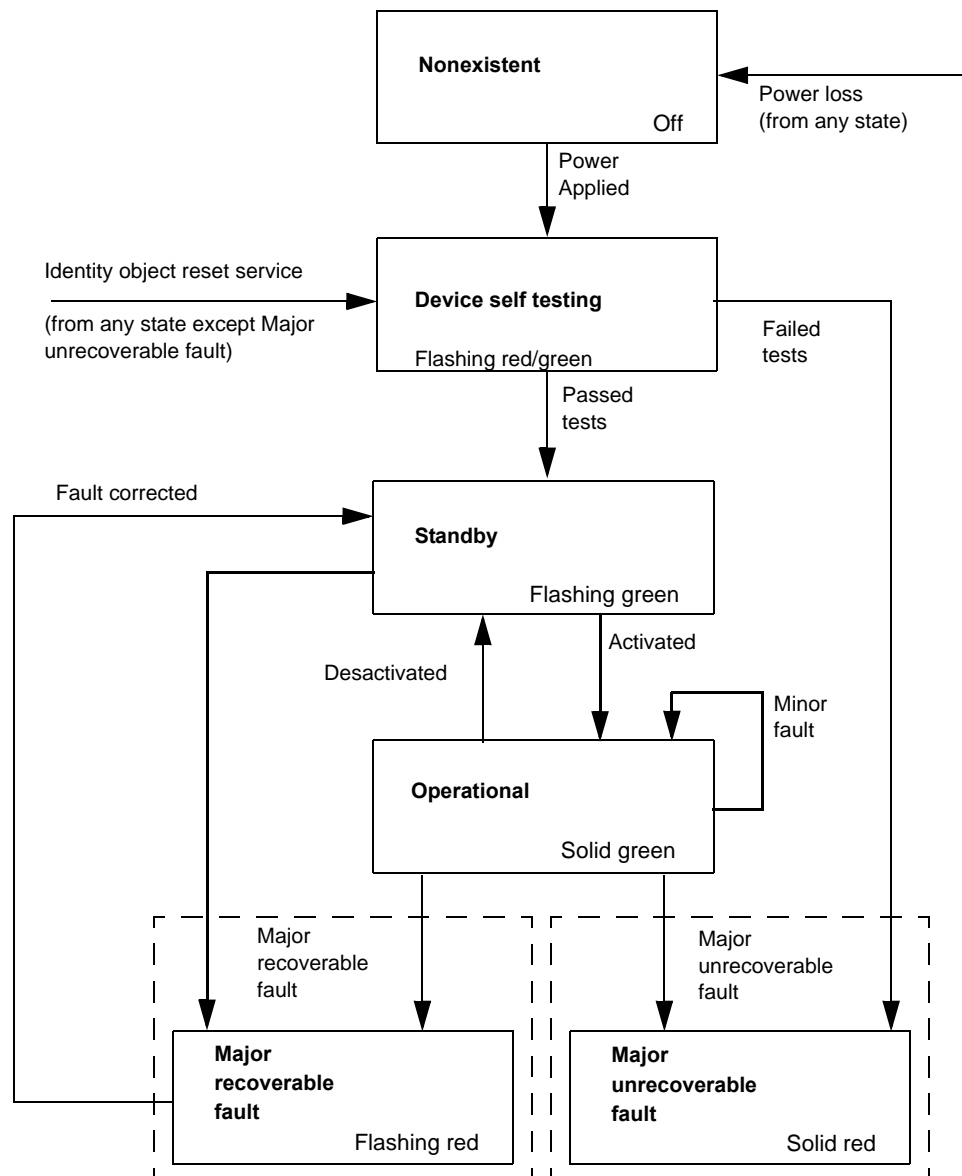

## 14. CIP objects

---

### 14. 3. Message router object

The Message router object is the element through which all the "Explicit messages" objects pass in order to be directed towards the objects they are truly destined to.

#### Class code

Hexadecimal	Decimal
16#02	2

#### Class attributes

Attribute ID	Access	Name	Need	Data type	Value	Details
1	Get	Revision	Opt.	UINT	1	-
2	Get	Max instances	Opt.	UNT	1	1 Defined instance

## 14. CIP objects

---

### Instance attributes

Attribute ID	Access	Name	Need	Data type	Value	Details
1	Get	Object list: Number classes	Opt.	Struct of: UINT UINT [ ]	20 (codes)	List of supported objects; the first UINT is the number of supported classes; the remaining UINTs are the codes of these classes.
2	Get	Number available	Opt.	UINT	1	Maximum number of simultaneous connections
3	Get	Number active	Opt.	UINT	1	Number of active connections
4	Get	Active connections	Opt.	UINT [ ]	1	List of active connections (referred to with their respective Connection instance ID)

### Class service

Service code	Service name	Need	Description
16#0E	Get_Attribute_Single	Req.	Read an attribute

### Instance service

Service code	Service name	Need	Description
16#0E	Get_Attribute_Single	Req.	Read an attribute

# 14. CIP objects

## 14. 4. Ethernet Link object

This object provides the mechanism to configure a device's TCP/IP network interface.

### ■ Class code

Hexadecimal	decimal
16#F5	245

### ■ Class attributes

Class attributes for this object are optional.

### ■ Instance attributes

Attribute ID	Access	Name	need	Data type	Value	Details	
1	Get	<b>Status</b>	Req.	DWORD	Bit level	0	The interface configuration attribute has not been configured.
						1	The interface configuration contains a valid configuration.
						2-15	Reserved for future use.
2	Get	<b>Configuration capability</b>	Req.	DWORD	Bit level	0	BOOTP Client.
						1	DNS Client.
						2	DHCP Client.
						3	DHCP-DNS capable.
						4	Interface configuration settable.
						All other bits are reserved and shall be set to 0.	
3	Get Set	<b>Configuration control</b>	Req.	DWORD	Bit level	0	The interface configuration is valid.
						1	The interface configuration must be obtained with BOOTP.
						2	The interface configuration must be obtained with DHCP..
						3	Reserved.
						4	DNS Enable.
All other bits are reserved and shall be set to 0.							
<b>NOTE : This attribute interacts with the Altivar 61/71 parameter [IPmode]. (see chapter 9.).</b>							
4	Get	<b>Physical link</b>	Req.	STRUCT { UINT <b>path size</b> Padded EPATH <b>path</b> }		<b>Path size:</b> number of 16 bit words in the element Path <b>Path:</b> Logical segments identifying the physical link object. The path is restricted to one logical class segment and one logical instance segment. The maximum size is 12 bytes.	

## 14. CIP objects

Attribute ID	Access	Name	need	Data type	Value	Details
5	Get Set	<b>Interface configuration</b>	Req.	STRUCT { UDINT <b>IP Address</b> UDINT <b>Network Mask</b> UDINT <b>Gateway address</b> UDINT <b>Primary Name</b> server UDINT <b>Secondary name</b> server STRING <b>Default Domain name</b> }		<p><b>IP Address:</b> Value of 0 indicates no IP address has been configured. Otherwise, the IP address shall be set to a valid Class A, B, or C address and shall not be set to the loopback address (127.0.0.1).</p> <p><b>Network Mask:</b> Value of 0 indicates no network mask address has been configured.</p> <p><b>Gateway Address:</b> Value of 0 indicates no IP address has been configured. Otherwise, the IP address shall be set to a valid Class A, B, or C address and shall not be set to the loopback address (127.0.0.1).</p> <p><b>Primary name:</b> Value of 0 indicates no name server address has been configured. Otherwise, the name server address shall be set to a valid Class A, B, or C address.</p> <p><b>Secondary Name:</b> Value of 0 indicates no secondary name server address has been configured. Otherwise, the name server address shall be set to a valid Class A, B, or C address.</p> <p><b>Default domain name:</b> ASCII characters. Maximum length is 48 characters. Shall be padded to an even number of characters (pad not included in length). A length of 0 shall indicate no Domain Name is configured.</p>
6	Get Set	<b>Host Name</b>	Req.	STRING		ASCII characters. Maximum length is 64 characters. Shall be padded to an even number of characters (pad not included in length). A length of 0 shall indicate no Host Name is configured.

### ■ Class service

Service Code	Service Name	Need	Description
16#01	Get_Attribute_All	Optional	Returns a predefined listing of this objects attributes.
16#0E	Get_Attribute_Single	Optional	Returns the contents of the specified attribute.

### ■ Instance service

Service Code	Service Name	Need	Description
16#01	Get_Attribute_All	Optional	Returns a predefined listing of this objects attributes.
16#0E	Get_Attribute_Single	Required	Returns the contents of the specified attribute.
16#02	Set_Attribute_All	optional	Modifies all settable attributes.
16#10	Set_Attribute_Single	Required	Modifies a single attribute.

# 14. CIP objects

## ■ Behaviour

The following state machine is used to configure the TCP/IP network interface.

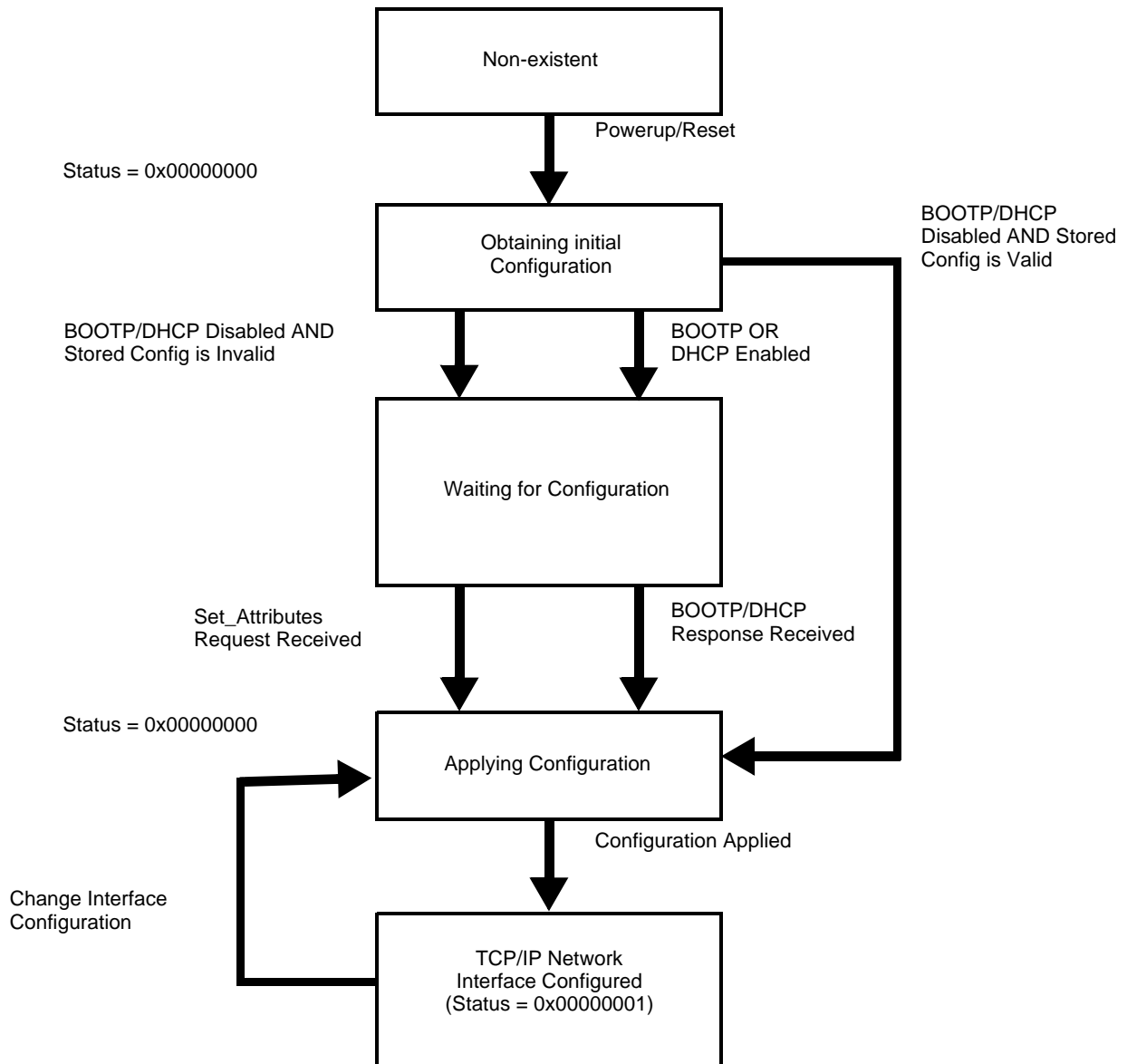

## 14. CIP objects

### 14. 5. TCP/IP Interface object

This object maintains link specific counters and status information for an Ethernet 802.3 communications interface.

#### ■ Class code

Hexadecimal	Decimal
16#F6	246

#### ■ Class attributes

Attribute ID	Access	Name	Need	Data type	Value
1	Get	Revision	Req.	UINT	2
2 through 7			optional		

#### ■ Instance attributes ../

Attribute ID	Access	Name	Need	Data type	Value	Details										
1	Get	<b>Interface Speed</b>	Req.	UDINT	0,10,100 1000, etc.	Speed in Mbps.										
2	Get	<b>Interface flags</b>	Req.	DWORD	Bit level	<table border="1"> <tr> <td><b>0</b></td> <td>Link status</td> </tr> <tr> <td><b>1</b></td> <td>Half/full duplex</td> </tr> <tr> <td><b>2-4</b></td> <td>Negotiation status</td> </tr> <tr> <td><b>5</b></td> <td>Manual setting / requires reset</td> </tr> <tr> <td><b>6</b></td> <td>Local Hardware fault</td> </tr> </table> <p>All other bits are reserved and shall be set to 0.</p>	<b>0</b>	Link status	<b>1</b>	Half/full duplex	<b>2-4</b>	Negotiation status	<b>5</b>	Manual setting / requires reset	<b>6</b>	Local Hardware fault
<b>0</b>	Link status															
<b>1</b>	Half/full duplex															
<b>2-4</b>	Negotiation status															
<b>5</b>	Manual setting / requires reset															
<b>6</b>	Local Hardware fault															
3	Get	<b>Physical Address</b>	Req.	ARRAY OF 6 USINTs		This array contains the MAC address of the card.Format: XX-XX-XX-XX-XX-XX										
4 ...	Get	<b>Interface counters</b>	Cond.	<b>STRUCT {</b>												
				<i>UDINT In Octets</i>		<i>Octets received on the interface</i>										
				<i>UDINT In Ucast Packets</i>		<i>Unicast Packets received on the interface.</i>										
				<i>UDINT In NUCast Packets</i>		<i>Non Unicast Packets received on the interface.</i>										
				<i>UDINT In Discards</i>		<i>Inbound packets received on the interface but discarded.</i>										
				<i>UDINT In Errors</i>		<i>Inbound packets that contain errors. (does not include in Discards)</i>										
				<i>UDINT In Unknown Protos</i>		<i>Inbound packets with unknown protocol.</i>										
				<i>UDINT Out Octets</i>		<i>Octets sent on the interface.</i>										
				<i>UDINT Out Ucast packest</i>		<i>Unicast Packets sent on the interface.</i>										
				<i>UDINT Out NUCast Packets</i>		<i>Non Unicast Packets sent on the interface.</i>										
				<i>UDINT Out discards</i>		<i>Outbound packets discarded</i>										
				<i>UDINT</i>		<i>Outbound packets that contain errors</i>										
				<b>}</b>												

## 14. CIP objects

Attribute ID	Access	Name	Need	Data type	Value	Details
5	Get	<b>Media Counters</b>	Cond.	<b>STRUCT {</b>		
				<b>UDINT Alignment errors</b>		Frames received that are not an integral number of octets in length
				<b>UDINT FCS Errors</b>		Frames received that do not pass the FCS check
				<b>UDINT Single collisions</b>		Successfully transmitted frames which experienced exactly one collision
				<b>UDINT Multiple Collisions</b>		Successfully transmitted frames which experienced more than one collision
				<b>UDINT SQE Test Errors</b>		Number of times SQE test error message is generated
				<b>UDINT Deferred Transmissions</b>		Frames for which first transmission attempt is delayed because the medium is busy
				<b>UDINT Late Collisions</b>		Number of times a collision is detected later than 512 bittimes into the transmission of a packet
				<b>UDINT Excessive Collisions</b>		Frames for which transmission fails due to excessive collision
				<b>UDINT MAC Transmit errors</b>		Frames for which transmission fails due to an internal MAC sublayer transmit error
				<b>UDINT Carrier sense Errors</b>		Times that the carrier sense condition was lost or never asserted when attempting to transmit a frame
				<b>UDINT Frame too long</b>		Frames received that exceed the maximum permitted frame size
				<b>UDINT MAC Receive Errors</b>		Frames for which reception on an interface fails due to an internal MAC sublayer receive error
		<b>}</b>				
6	Set	<b>Interface control</b>	Optional	<b>STRUCT {</b>		
				<b>WORD Control Bits</b>		Interface control bits
				<b>UINT Force interface Speed</b>		Speed at which the interface shall be forced to operate.
				<b>}</b>		

## 14. CIP objects

### ■ Class service

Service Code	Service Name	Need	Description
16#01	Get_Attribute_All	Optional	Returns a predefined listing of this objects attributes.
16#0E	Get_Attribute_Single	Optional	Returns the contents of the specified attribute.
16#10	Get_and_clear	Cond.	Modifies a single attribute

### ■ Instance service

Service Code	Service Name	Need	Description
16#01	Get_Attribute_All	Optional	Returns a predefined listing of this objects attributes.
16#0E	Get_Attribute_Single	Required	Returns the contents of the specified attribute.
16#10	Set_Attribute_Single	Required	Modifies a single attribute.

## 14. 6. Connection object manager

### Class code

Hexadecimal	Decimal
16#05	5

### Class attributes

Attribute ID	Access	Name	Need	Data type	Value	Details
1	Get	Revision	Opt.	UINT	1	—
2	Get	Max instances	Opt.	UINT	4	3 defined instances (1)

(1) Only instances 1 (explicit message), 2 (polled I/O message), and 4 (change of state/cyclic message) are supported. Instance 3 (bit strobe) is not supported.

### Attributes of instance 1—Explicit message instance

Attribute ID	Access	Name	Need	Data type	Value	Details
1	Get	State	Req.	USINT	—	0 : Non-existent 3 : Established 5 : Deferred Delete
2	Get	Instance_type	Req.	USINT	0	Explicit Message
3	Get	TransportClass_trigger	Req.	BYTE	16#83	Class 3 server
4	Get	Produced_connection_id	Req.	UINT	10xxxxxx011	xxxxxx = Node address
5	Get	Consumed_connection_id	Req.	UINT	10xxxxxx100	xxxxxx = Node address
6	Get	Initial_comm_characteristics	Req.	BYTE	16#21	Explicit messaging via Group 2
7	Get	Produced_connection_size	Req.	UINT	36	Produced data maximum size (in bytes)
8	Get	Consumed_connection_size	Req.	UINT	36	Consumed data maximum size (in bytes)
9	Get/Set	Expected_packet_rate	Req.	UINT	2500	2.5 sec. (TimeOut)
12	Get/Set	Watchdog_timeout_action	Req.	USINT	1 or 3	1 : Auto-Delete 3 : Deferred Delete (Default)
13	Get	Produced connection path length	Req.	UINT	0	Length of attribute 14 data
14	Get	Produced connection path	Req.	Array of UINT	Null	Empty
15	Get	Consumed connection path length	Req.	UINT	0	Length of attribute 16 data
16	Get	Consumed connection path	Req.	Array of UINT	Null	Empty

Refer to EtherNet/IP specification for more information.

# 14. CIP objects

## 14. 7. Motor data object

The Motor data object acts as a motor parameter database.

### Class code

Hexadecimal	Decimal
16#28	40

### Object 28hex (Motor Data)

Path	CIP name	CIP configuration parameter name
16#28/01/06 = 40/1/6	RatedCurrent	Motor Rated Cur
16#28/01/07 = 40/1/7	RatedVoltage	Motor Rated Volt
16#28/01/09 = 40/1/9	RatedFreq	Motor Rated Freq
16#28/01/0F = 40/1/15	BaseSpeed	Motor Base Speed

### Schneider-Electric adaptation:

Path	Code	Altivar name	Logic address
16#28/01/06 = 40/1/6	NCR	Rated mot. current	16#2583 = 9603
16#28/01/07 = 40/1/7	UNS	Rated motor volt.	16#2581 = 9601
16#28/01/09 = 40/1/9	FRS	Rated motor freq.	16#2582 = 9602
16#28/01/0F = 40/1/15	NSP	Rated motor speed	16#2584 = 9604

### Class attributes

Attribute ID	Access	Name	Need	Data type	Value	Details
1	Get	Revision	Opt.	UINT	2	—
2	Get	Max instance	Opt.	UINT	1	—
6	Get	Max ID number of class attribute	Opt.	UINT	7	—
7	Get	Max ID number of instance attribute	Opt.	UINT	15	—

### Instance attributes

Attribute ID	Access	Name	Need	Data type	Value	Details
3	Get/Set	MotorType	Req.	USINT	7	6 = Wound rotor induction motor 7 = Squirrel cage induction motor
6	Get/Set	RatedCurrent	Req.	UINT	Depends on the drive rating	[Rated mot. current] ( <i>n C r</i> )
7	Get/Set	RatedVoltage	Req.	UINT	Depends on the drive rating	[Rated mot. volt.] ( <i>U n S</i> )
9	Get/Set	RatedFreq	Opt.	UINT	50/60	[Rated motor freq.] ( <i>F r S</i> )
15	Get/Set	BaseSpeed	Opt.	UINT	Depends on the drive rating	[Nom motor speed] ( <i>n S P</i> )

### Class service

Service code	Service name	Need	Description
16#0E	Get_Attribute_Single	Req.	Read an attribute

### Instance service

Service code	Service name	Need	Description
16#0E	Get_Attribute_Single	Req.	Read an attribute
16#10	Set_Attribute_Single	Opt.	Write an attribute

# 14. CIP objects

## 14. 8. Control supervisor object

The Control supervisor object models the functions for managing all devices within the hierarchy of motor control devices.

### Object 29hex (Control Supervisor)

Path	CIP name	CIP configuration parameter name
16#29/01/0D = 41/1/13	FaultCode	Fault Code

### Schneider-Electric adaptation:

Path	Code	Altivar name	Logic address
16#29/01/0D = 41/1/13	ERRD	CiA402 fault code	16#219E = 8606

### Class code

Hexadecimal	Decimal
16#29	41

### Class attributes

Attribute ID	Access	Name	Need	Data type	Value	Details
1	Get	Revision	Opt.	UINT	2	—
2	Get	Max instance	Opt.	UINT	1	—
6	Get	Max ID number of class attribute	Opt.	UINT	7	—
7	Get	Max ID number of instance attribute	Opt.	UINT	17	—

### Instance attributes

Attribute ID	Access	Name	Need	Data type	Details
3	Get/Set	Run Fwd	Req.	BOOL	On an edge (0 →1)
4	Get/Set	Run Rev	Opt.	BOOL	On an edge (0 →1)
5	Get/Set	NetCtrl	Opt.	BOOL	0: Local Control (Channel 1) 1: Network Control (default)
6	Get	State	Opt.	USINT	0 = Vendor Specific, 1 = Startup, 2 = Not_Ready, 3 = Ready, 4 = Enabled, 5 = Stopping, 6 = Fault_Stop, 7 = Faulted
7	Get	Running Fwd	Req.	BOOL	
8	Get	Running Rev	Opt.	BOOL	
9	Get	Ready	Opt.	BOOL	
10	Get	Faulted	Req.	BOOL	
12	Get/Set	FaultRst	Req.	BOOL	Fault reset (0 →1)
13	Get	FaultCode	Opt.	UINT	Refer to the Communication parameters manual: DSP402 fault code (Errd)
15	Get	CtrlFromNet	Opt.	BOOL	0 = Local Control; 1 = Network Control

# 14. CIP objects

## Class service

Service Code	Service name	Need	Description
16#0E	Get_Attribute_Single	Req.	Read an attribute

## Instance service

Service Code	Service name	Need	Description
16#0E	Get_Attribute_Single	Req.	Read an attribute
16#10	Set_Attribute_Single	Req.	Write an attribute
16#05	Reset	Req.	Drive reset

Control supervisor state transition diagram

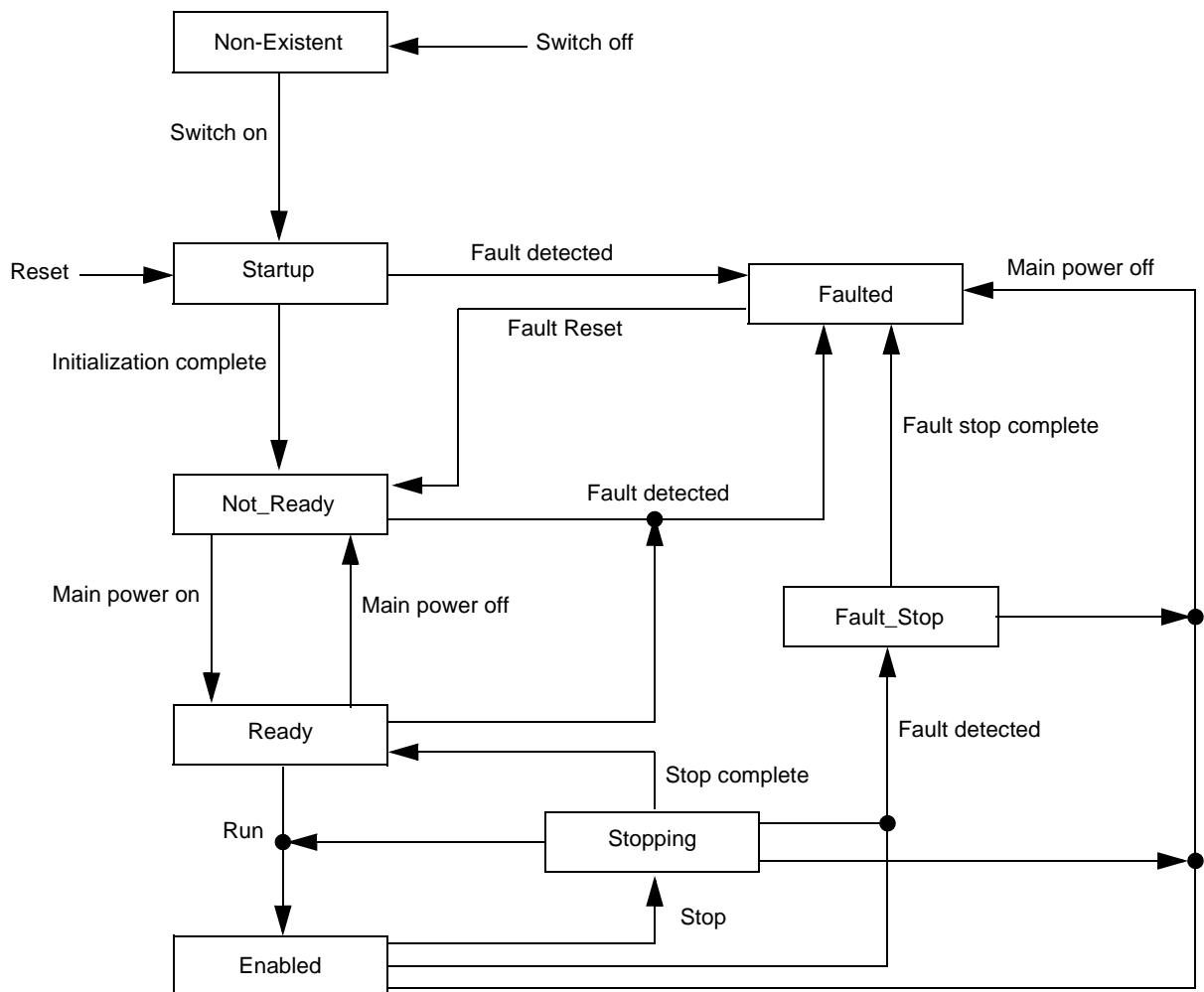

# 14. CIP objects

## 14.9. AC/DC Drive Object

The AC/DC Drive object models the functions (such as torque control and speed ramp) that are specific to drives.

### Class code

Hexadecimal	Decimal
16#2A	42

### Class attributes

Attribute ID	Access	Name	Need	Data Type	Value	Details
1	Get	Revision	Opt.	UINT	1	—
2	Get	Max instance	Opt.	UINT	1	—
6	Get	Max ID number of class attribute	Opt.	UINT	7	—
7	Get	Max ID number of instance attribute	Opt.	UINT	21	—

### Instance attributes

Attribute ID	Access	Name	Need	Data type	Details
3	Get	AtReference	Opt.	BOOL	
4	Get/Set	NetRef (1)	Req.	BOOL	0: Local speed setpoint (AI1 or AI2) 1: Speed setpoint via the network
5	Get/Set	NetProc	Opt.	BOOL	Not handled
6	Get/Set	Drive mode	Req.	USINT	1: Open loop 2: Closed loop (FVC)
7	Get	SpeedActual	Req.	INT	Output speed (rFrd)
8	Get/Set	SpeedRef	Req.	INT	Speed setpoint (LFrd)
9	Get	CurrentActual	Opt.	INT	Motor current (LCr)
10	Get/Set	CurrentLimit	Opt.	INT	[Mot. therm. current] (ItH)
11	Get	TorqueActual	Opt.	INT	Output torque (Otrn)
12	Get/Set	TorqueRef	Opt.	INT	Torque setpoint (LtCr)
18	Get/Set	AccelTime	Opt.	UINT	Acceleration time (ACCd)
19	Get/Set	DecelTime	Opt.	UINT	Deceleration time (dECd)
20	Get/Set	LowSpdLimit	Opt.	UINT	Parameter [Low speed] (LSP) converted in RPM
21	Get/Set	HighSpdLimit	Opt.	UINT	Parameter [High speed] (HSP) converted in RPM

### Class service

Service code	Service name	Need	Description
16#0E	Get_Attribute_Single	Req.	Read an attribute

### Instance service

Service code	Service name	Need	Description
16#0E	Get_Attribute_Single	Req.	Read an attribute
16#10	Set_Attribute_Single	Opt.	Write an attribute

# 14. CIP objects

## 14. 10. Assembly object

The Assembly object binds together the attributes of multiple objects so that information to or from each object can be communicated over a single connection.

Assembly objects are static.

The assemblies in use can be modified through the parameter access of the network configuration tool (RSNetWorx).

The drive needs a power off to take into account a new assembly assignment.

### Class code

Hexadecimal	Decimal
16#04	4

### Class attribute

Attribute ID	Access	Name	Need	Data type	Value	Details
1	Get	Revision	Opt.	UINT	2	—
2	Get	Max instance	Opt.	UINT	105	13 defined instances

### Instances supported

Instance	Name	Data size
20	ODVA Basic speed control output	4 bytes
21	ODVA Extended speed control output	4 bytes
22	ODVA Speed and torque control output	6 bytes
23	ODVA Extended speed and torque control output	6 bytes
100	Native drive output	16 bytes
103	Allen-Bradley® drive output	20 bytes
70	ODVA Basic speed control input	4 bytes
71	ODVA Extended speed control input	4 bytes
72	ODVA Speed and torque control input	6 bytes
73	ODVA Extended speed and torque control input	6 bytes
101	Native drive input	16 bytes
104	Allen-Bradley® drive input	20 bytes

The description of each instance is detailed in chapter [16. Device profiles](#)

### Instance attributes

Attribute ID	Access	Name	Need	Data type	Value	Details
3	Get/Set (1)	Data	Req.			

(1) Set access is restricted to output instances only (instances 20, 21, 22, 23, 100 and 103).

### Class service

Service code	Service name	Need	Description
16#0E	Get_Attribute_Single	Req.	Read an attribute

### Instance service

Service code	Service name	Need	Description
16#0E	Get_Attribute_Single	Req.	Read an attribute
16#10	Set_Attribute_Single	Opt.	Write an attribute

# 14. CIP objects

## 14. 11. Application objects

### Class code

Hexadecimal	Decimal
16#70 to 16#A8	112 to 424

### Altivar parameters path

The Altivar parameters are grouped in classes.  
Each application class has only 1 instance.  
Each instance groups 200 parameters.  
Each attribute in an instance relates to a parameter.

The first parameter registered in the first application class (class code: 16#70 = 112) has the logical address 3000.

Examples:

Logical address	Path Hexadecimal	Path decimal
3 000	16# 70 / 01 / 01	112 / 1 / 1
3 100	16# 70 / 01 / 65	112 / 1 / 101
3 200	16# 71 / 01 / 01	113 / 1 / 1
64 318	16# A2 / 1 / 77	418 / 1 / 119

Refer to the Communication parameters manual.

### Class attributes

Attribute ID	Access	Name	Need	Data type	Value
1	Get	Revision	Opt.	UINT	1
2	Get	Max instance	Opt.	UINT	1
6	Get	Max ID number of class attribute	Opt.	UINT	7
7	Get	Max ID number of instance attribute	Opt.	UINT	X

### Instance attributes

Attribute ID	Access	Name	Data type	Value
1	Get/Set	First parameter of the class	UINT / USINT	Value returned by the drive
...	...	...	...	...
X	Get/Set	Last parameter of the class	UINT / USINT	Value returned by the drive

Note: Depending on the parameter, write access may be prohibited. Refer to the Communication parameters manual for more information.

### Class service

Service code	Service name	Need	Description
16#0E	Get_Attribute_Single	Req.	Read an attribute

### Instances service

Service code	Service name	Need	Description
16#0E	Get_Attribute_Single	Req.	Read an attribute
116#0	Set_Attribute_Single	Opt.	Write an attribute

## 14. CIP objects

---

### ■ Object 2Ahex (AC/DC Drive)

Path	CIP name	CIP configuration parameter name
16#2A/01/07 = 42/1/7	SpeedActual	Speed Actual
16#2A/01/08 = 42/1/8	SpeedRef	Speed Reference
16#2A/01/09 = 42/1/9	CurrentActual	Current Actual
16#2A/01/0A = 42/1/10	CurrentLimit	Current Limit
16#2A/01/0B = 42/1/11	TorqueActual	Torque Actual
16#2A/01/0C = 42/1/12	TorqueRef	Torque Reference
16#2A/01/12 = 42/1/18	AccelTime	Accel Time
16#2A/01/13 = 42/1/19	DecelTime	Decel Time
16#2A/01/14 = 42/1/20	LowSpdLimit	Low Speed Limit
16#2A/01/15 = 42/1/21	HighSpdLimit	High Speed Limit

### Schneider-Electric adaptation:

Path	Code	Altivar name	Logic address	Unit Id
16#2A/01/07 = 42/1/7	RFRD	Output velocity	16#219C = 8604	
16#2A/01/08 = 42/1/8	LFRD	Speed setpoint	16#219A = 8602	
16#2A/01/09 = 42/1/9	LCR	Motor current	16#0C84 = 3204	
16#2A/01/0A = 42/1/10	ITH	Mot. therm. current	16#2596 = 9622	
16#2A/01/0B = 42/1/11	Otrn	Output torque (Nm)	16#2A0B = 10763	251
16#2A/01/0C = 42/1/12	n.a.	Torque setpoint (Nm)	16#2A0C = 10764	251
16#2A/01/12 = 42/1/18	ACCD	CIP acceleration time	16#2A12 = 10770	251
16#2A/01/13 = 42/1/19	DECD	CIP deceleration time	16#2A13 = 10771	251
16#2A/01/14 = 42/1/20	LSPD	CIP Low speed limit	16#2A14 = 10772	251
16#2A/01/15 = 42/1/21	HSPD	CIP High speed limit	16#2A15 = 10773	251

# 15. Explicit Messaging

The following example shows an example of explicit messaging: The value of the ACC parameter ( Modbus @ = 9001 / CIP address 16#2A:1:16#12 ) is modified when the variable "bit01" is toggled ON.

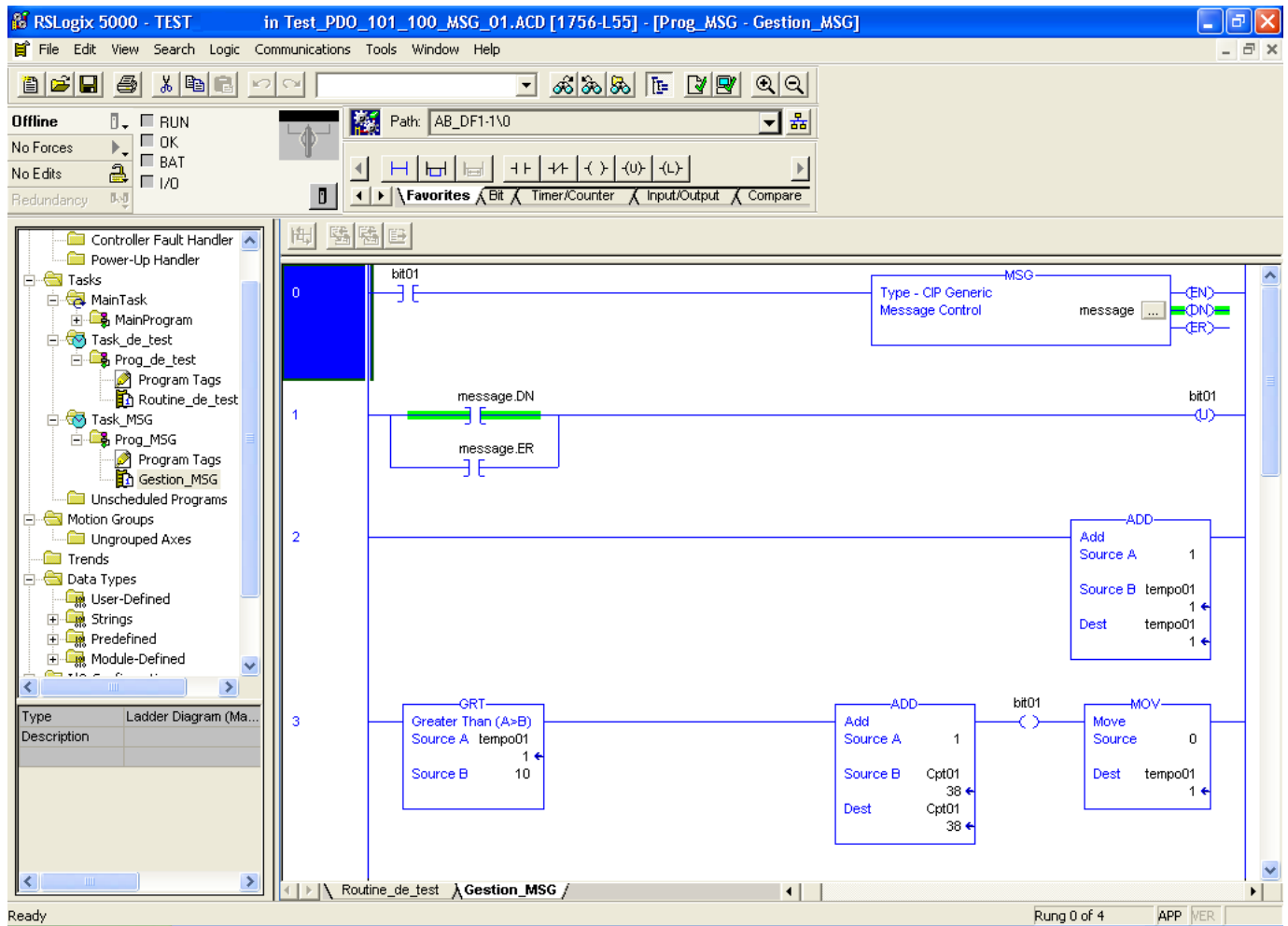

The detailed configuration of the message Box:

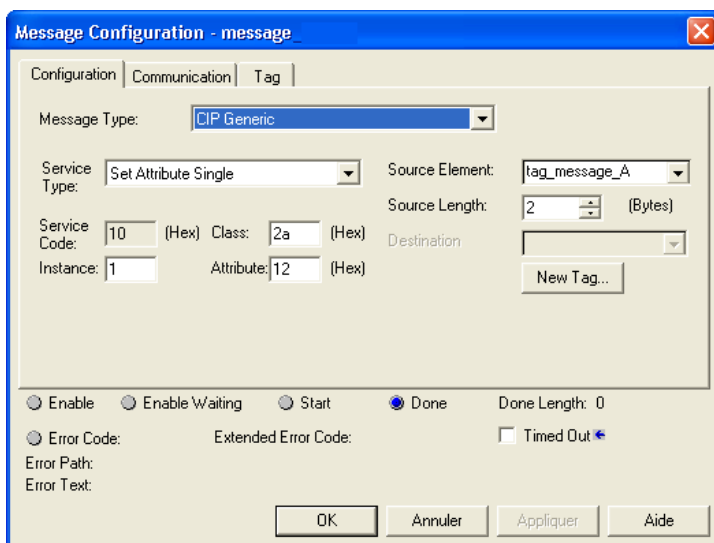

## 16. Device profiles

EtherNet/IP card provides several profiles:

- CIP AC drive profile (0x02) (default setting),
- Allen Bradley drive profile,
- Schneider-Electric: CiA 402 and I/O.

The profile is chosen by the selection of the right input assembly and output assembly.

In this manual, the chapter "Integration in RSLogix 5000" shows how the user may select the assemblies.

### ■ List of assemblies

#### Output assemblies

Assembly name	Number	Size
CIP basic speed control output	20	2 words (4 bytes)
CIP extended speed control output	21	2 words (4 bytes)
CIP speed and torque control output	22	3 words (6 bytes)
CIP extended speed and torque control output	23	3 words (6 bytes)
Native drive output	100	2 to 10 words (4 to 20 bytes)
Allen-Bradley® drive output	103	2 to 10 words (4 to 20 bytes)

#### Input assemblies

Assembly name	Number	Size
CIP basic speed control input	70	2 words (4 bytes)
CIP extended speed control input	71	2 words (4 bytes)
CIP speed and torque control input	72	3 words (6 bytes)
CIP extended speed and torque control input	73	3 words (6 bytes)
Native drive input	101	2 to 10 words (4 to 20 bytes)
Allen-Bradley® drive input	104	2 to 10 words (4 to 20 bytes)

#### REMARK:

For the assemblies 20 and 22, the default settings defines that the speed setpoint is originated from the terminals. To fully control the drive from the network the following operation is required:

The object 2A/1/4 (netref) must be changed from 0 to 1 (byte). Such assignment can be done:

- By program, with an MSG() instruction block.
- With the Class instance editor:

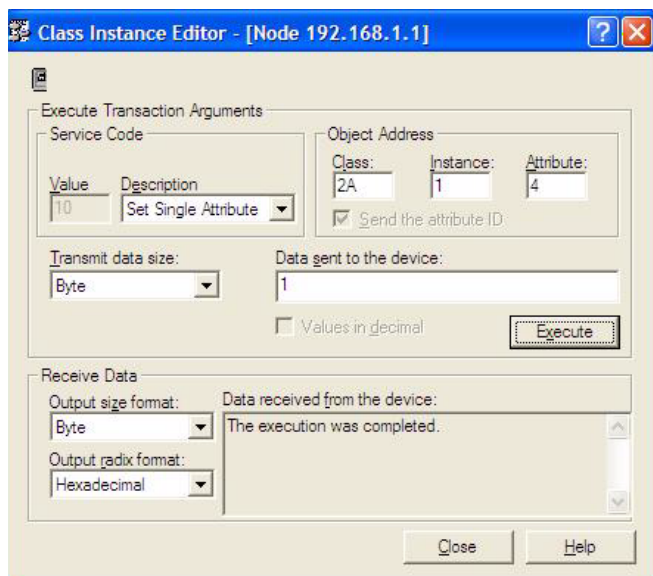

## 15. Device profiles

### ■ Assembly 20: CIP basic speed control output

#### Assembly mapping

Word number	Definition
0	CIP basic command word
1	Speed setpoint (rpm)

#### CIP basic command word

Bit 7	Bit 6	Bit 5	Bit 4	Bit 3	Bit 2	Bit 1	Bit 0
Not used	Not used	Not used	Not used	Not used	Fault reset (1) 0 = No command 1 = Fault reset	Not used	Run Forward (2) 0 = Stop 1 = Run

(1) Active on rising edge.

(2) Active on level.

Bit 15	Bit 14	Bit 13	Bit 12	Bit 11	Bit 10	Bit 9	Bit 8
Not used	Not used	Not used	Not used	Not used	Not used	Not used	Not used

### ■ Assembly 70: CIP basic speed control input

#### Assembly mapping

Word number	Definition
0	CIP basic status word
1	Actual speed (rpm)

#### CIP basic status word

Bit 7	Bit 6	Bit 5	Bit 4	Bit 3	Bit 2	Bit 1	Bit 0
Not used	Not used	Not used	Not used	Not used	Running 0 = Stopped 1 = Running	Not used	Faulted 0 = No fault 1 = Fault

Bit 15	Bit 14	Bit 13	Bit 12	Bit 11	Bit 10	Bit 9	Bit 8
Not used	Not used	Not used	Not used	Not used	Not used	Not used	Not used

### ■ Assembly 21: CIP extended speed control output

#### Assembly mapping

Word number	Definition
0	CIP extended command word
1	Speed setpoint (rpm)

#### CIP extended command word

Bit 7	Bit 6	Bit 5	Bit 4	Bit 3	Bit 2	Bit 1	Bit 0
Not used	Network setpoint 0 = Setpoint by terminals 1 = Setpoint by network	Network command 0 = Command by terminals 1 = Command by network	Not used	Not used	Fault reset (1) 0 = No command 1 = Fault reset	Run forward / reverse 00 = Quick stop 01 = Run forward 10 = Run reverse 11 = Freewheel stop	

Bit 15	Bit 14	Bit 13	Bit 12	Bit 11	Bit 10	Bit 9	Bit 8
Not used	Not used	Not used	Not used	Not used	Not used	Not used	Not used

(1) Active on rising edge.

## 15. Device profiles

### ■ Assembly 71: CIP extended speed control input

#### Assembly mapping

Word number	Definition
0	CIP extended status word
1	Actual speed (rpm)

#### CIP extended status word

Bit 7	Bit 6	Bit 5	Bit 4	Bit 3	Bit 2	Bit 1	Bit 0
At reference 0 = Reference not reached 1 = Reference reached	Setpoint from network 0 = Setpoint from terminals 1 = Setpoint from network	Command from network 0 = Command from terminals 1 = Command from network	Ready 0 = Not ready 1 = Ready	Running forward / reverse  00 = Stopped 01 = Running forward 10 = Running reverse 11 = Not used	Warning  0 = No warning 1 = Warning	Faulted 0 = No fault 1 = Fault	

Bit 15	Bit 14	Bit 13	Bit 12	Bit 11	Bit 10	Bit 9	Bit 8
Not used	Not used	Not used	Not used	Not used	Bit 8 to bit 10 are used for the drive state 000 = Not used 001 = Startup 010 = Not Ready 011 = Ready 100 = Enabled 101 = Stopping 110 = Fault Stop 111 = Faulted		

### ■ Assembly 22: CIP speed and torque control output

#### Assembly mapping

Word number	Definition
0	CIP basic command word (1)
1	Speed setpoint (rpm)
2	Torque setpoint (Nm)

(1) Refer to assembly 20.

### ■ Assembly 72: CIP speed and torque control input

#### Assembly mapping

Word number	Definition
0	CIP basic status word (1)
1	Actual speed (rpm)
2	Actual torque (Nm)

(1) Refer to assembly 70.

### ■ Assembly 23: CIP extended speed and torque control output

#### Assembly mapping

Word number	Definition
0	CIP extended command word (1)
1	Speed setpoint (rpm)
2	Torque setpoint (Nm)

(1) Refer to assembly 21.

## 15. Device profiles

---

### ■ Assembly 73: CIP extended speed and torque control input

#### Assembly mapping

Word number	Definition
0	CIP extended status word (1)
1	Actual speed (rpm)
2	Actual torque (Nm)

(1) Refer to assembly 71.

### ■ Assembly 100: Native drive output

#### Assembly mapping

Word number	Definition
0	Control word
1	Velocity setpoint
2	Scanner write word 1
3	Scanner write word 2
4	Scanner write word 3
5	Scanner write word 4
6	Scanner write word 5
7	Scanner write word 6

#### Altivar 61/71 assignment

Word number	Code	Name	Logic address
0	NC1	Communication scanner, value of write word 1 (default value :CMD, Control word)	16#31D9 = 12761
1	NC2	Communication scanner, value of write word 2 (default value: LFRD, velocity setpoint)	16#31DA = 12762
2	NC3	Communication scanner, value of write word 3	16#31DB = 12763
3	NC4	Communication scanner, value of write word 4	16#31DC = 12764
4	NC5	Communication scanner, value of write word 5	16#31DD = 12765
5	NC6	Communication scanner, value of write word 6	16#31DE = 12766
6	NC7	Communication scanner, value of write word 7	16#31DF = 12767
7	NC8	Communication scanner, value of write word 8	16#31E0 = 12768

**Note:** The default assignment of NC1 and NC2 must be changed to "Not assigned".

## 15. Device profiles

---

### ■ Assembly 101: Native drive input

#### Assembly mapping

Word number	Definition
0	Scanner read word 1
1	Scanner read word 2
2	Scanner read word 3
3	Scanner read word 4
4	Scanner read word 5
5	Scanner read word 6
6	Scanner read word 7
7	Scanner read word 8

#### Altivar 71/61 assignment

Word number	Code	Name	Logic address
0	NM1	Communication scanner, value of read word 1 (default value: Status word, ETA)	16#31C5 = 12741
1	NM2	Communication scanner, value of read word 2 (default value: Velocity actual value, RFRD)	16#31C6 = 12742
2	NM3	Communication scanner, value of read word 3	16#31C7 = 12743
3	NM4	Communication scanner, value of read word 4	16#31C8 = 12744
4	NM5	Communication scanner, value of read word 5	16#31C9 = 12745
5	NM6	Communication scanner, value of read word 6	16#31CA = 12746
6	NM7	Communication scanner, value of read word 7	16#31CB = 12747
7	NM8	Communication scanner, value of read word 8	16#31CC = 12748

## 15. Device profiles

---

### ■ Assembly 103: Allen-Bradley® drive output

#### Assembly mapping

Word number	Definition
0	Allen-Bradley® drive logic command
1	Standardized speed setpoint (reference)
2	Scanner write word 1
3	Scanner write word 2
4	Scanner write word 3
5	Scanner write word 4
6	Scanner write word 5
7	Scanner write word 6
8	Scanner write word 7
9	Scanner write word 8

#### Altivar 61/71 assignment

Word number	Code	Name	Logic address
0	n.a.	Allen-Bradley® drive logic command	n.a.
1	LFR	Frequency setpoint	16#2136 = 8502
2	NC1	Communication scanner, value of write word 1	16#31D9 = 12761
3	NC2	Communication scanner, value of write word 2	16#31DA = 12762
4	NC3	Communication scanner, value of write word 3	16#31DB = 12763
5	NC4	Communication scanner, value of write word 4	16#31DC = 12764
6	NC5	Communication scanner, value of write word 5	16#31DD = 12765
7	NC6	Communication scanner, value of write word 6	16#31DE = 12766
8	NC7	Communication scanner, value of write word 7	16#31DF = 12767
9	NC8	Communication scanner, value of write word 8	16#31E0 = 12768

**Note:** The default assignment of NC1 and NC2 must be changed to another value or to not assigned..

# 15. Device profiles

## ■ Allen-Bradley® drive logic command

The logic command is a 16-bit word of control produced by the scanner and consumed by the EtherNet/IP card.

If enabled, the Logic command word is always word 0 in the output image.

Bit 7	Bit 6	Bit 5 Bit 4	Bit 3	Bit 2	Bit 1	Bit 0
MOP Increment 0 = Not Increment 1 = Increment	Local control 0 = No local control 1 = Local control	Direction 00 = No command (4) 01 = Forward command 10 = Reverse command 11 = Hold direction control	Clear faults (3) 0 = Not clear faults 1 = Clear faults	Jog 0 = Not jog 1 = Jog	Start (2) 0 = Not start 1 = Start	Stop (1) 0 = Not stop 1 = Stop

Bit 15	Bit 14	Bit 13	Bit 12	Bit 11 Bit 10	Bit 9 Bit 8
MOP Decrement 0 = Not decrement 1 = Decrement	Reference select 000 = No command (7) 001 = Setpoint 1 channel (Fr1) 010 = Setpoint 2 channel (Fr2) 011 = Ref. 3 (Preset 3) 100 = Ref. 4 (Preset 4) 101 = Ref. 5 (Preset 5) 110 = Ref. 6 (Preset 6) 111 = Ref. 7 (Preset 7)			Decel rate 00 = No command (6) 01 = Decel rate 1 command 10 = Decel rate 2 command 11 = Hold decel rate	Accel rate 00 = No command (5) 01 = Accel rate 1 command 10 = Accel rate 2 command 11 = Hold accel rate

- (1) Stop: Active at level.
- (2) Start: Active on rising edge. A Not stop condition (logic 0 = 0) must first be present before a Start condition (logic 1 = 1) will start the drive.
- (3) Clear faults: Active on rising edge. To perform this command, the value must switch from "0" to "1."
- (4) Direction \ No command: If a direction is selected acts like Hold direction control.
- (5) Accel rate \ No command: If a rate is selected acts like Hold accel rate.
- (6) Decel rate \ No command: If a rate is selected acts like Hold decel rate.
- (7) Reference select \ No command: If a rate is selected acts like Hold command.

## ■ Altivar 61/71 assignment

Bit 7	Bit 6	Bit 5 Bit 4	Bit 3	Bit 2	Bit 1	Bit 0
Not used	Not used	Direction 00 = No command (4) 01 = Forward command 10 = Reverse command 11 = Hold direction control	Clear faults (3) 0 = Not clear faults 1 = Clear faults	Not used	Start (2) 0 = Not start 1 = Start	Stop (1) 0 = Not stop 1 = Stop

Bit 15	Bit 14	Bit 13	Bit 12	Bit 11	Bit 10	Bit 9	Bit 8
Not used	Setpoint select 000 = No command 001 = Terminals 010 = Control by network 011 = Preset 3 100 = Preset 4 101 = Preset 5 110 = Preset 6 111 = Preset 7			Not used	Not used	Not used	Not used

# 15. Device profiles

## ■ Standardised setpoint

The setpoint (16 bits only) is produced by the controller and consumed by the EtherNet/IP card. If enabled, the setpoint is always word 1 in the output image.

The setpoint value is a standardised (e.g. scaled) value; it is not an engineering value.

## Schneider-Electric adaptation

[Frequency setpoint] (*L F r*) shall be configured in high resolution: standardised value on 16 signed bits at maximum frequency. The value 32767 corresponds to the parameter [Max frequency] (*£ F r*). The default value of the parameter [Max frequency] (*£ F r*) is 60 Hz, and the resolution is then approximately 0.0018 Hz.

### Note:

The commanded maximum speed can never exceed the value of the parameter [High speed] (HSP).

The table below shows example setpoints and their results on an Altivar drive that has its parameter [Max frequency] (*£ F r*) set to 130 Hz and its parameter [High speed] (*H S P*) set to 60 Hz.

Setpoint value	Scale		Output speed	Feedback value
	Percent	Value		
32767 (1)	100%	130 Hz	60 Hz (2)	15123 (3)
16384	50%	65 Hz	60 Hz (2)	15123 (3)
8192	25%	32.5 Hz	32.5 Hz	8192
0	0%	0 Hz	0 Hz	0

(1) A value of 32767 is equivalent to the parameter [Max frequency] (*£ F r*) frequency value. Values greater than 32767 reverse speed.

(2) The drive runs at 60 Hz instead of 130 Hz or 65 Hz because the parameter [High speed] (*H S P*) sets 60 Hz as the maximum speed.

(3) The feedback value is also scaled based on the value of the parameter [Max frequency] (*£ F r*), for example,  $60/130 = 0.46$  so  $32767 \times 0.46 = 15123$ .

## ■ Assembly 104: Allen-Bradley® drive input

### Assembly mapping

Word number	Definition
0	Allen-Bradley® drive logic status
1	Speed feedback (actual value)
2	Scanner read word 1
3	Scanner read word 2
4	Scanner read word 3
5	Scanner read word 4
6	Scanner read word 5
7	Scanner read word 6
8	Scanner read word 7
9	Scanner read word 8

Word number	Code	Name	Logic address
0	n.a.	Allen-Bradley® drive logic status	n.a.
1	RFR	Output frequency	16#0C82 = 3202
2	NM1	Communication scanner, value of read word 1	16#31C5 = 12741
3	NM2	Communication scanner, value of read word 2	16#31C6 = 12742
4	NM3	Communication scanner, value of read word 3	16#31C7 = 12743
5	NM4	Communication scanner, value of read word 4	16#31C8 = 12744
6	NM5	Communication scanner, value of read word 5	16#31C9 = 12745
7	NM6	Communication scanner, value of read word 6	16#31CA = 12746
8	NM7	Communication scanner, value of read word 7	16#31CB = 12747
9	NM8	Communication scanner, value of read word 8	16#31CC = 12748

**Note:** The default assignment of NM1 and NM2 must be changed to "Not assigned".

# 15. Device profiles

## ■ Allen-Bradley® drive logic status

The Logic Status is a 16-bit word of status produced by the EtherNet/IP card and consumed by the scanner. If enabled, the Logic status word is always word 2 in the input image.

Bit 7	Bit 6	Bit 5	Bit 4	Bit 3	Bit 2	Bit 1	Bit 0
Fault	Alarm	Decelerating	Accelerating	Actual direction	Command direction	Active	Ready
0 = No fault 1 = Fault	0 = No alarm 1 = Alarm	0 = Not decelerating 1 = Decelerating	0 = Not accelerating 1 = Accelerating	0 = Reverse 1 = Forward	0 = Reverse 1 = Forward	0 = Not active 1 = Active	0 = Not ready 1 = Ready

Bit 15	Bit 14	Bit 13	Bit 12	Bit 11	Bit 10	Bit 9	Bit 8
Reference				Local control			At speed
0000 = Ref A auto 0001 = Ref B auto 0010 = Preset 2 auto 0011 = Preset 3 auto 0100 = Preset 4 auto 0101 = Preset 5 auto 0110 = Preset 6 auto 0111 = Preset 7 auto 1000 = Term blk manual 1001 = DPI 1 manual 1010 = DPI 2 manual 1011 = DPI 3 manual 1100 = DPI 4 manual 1101 = DPI 5 manual 1110 = DPI 6 manual 1111 = Jog reference				000 = Port 0 (TB) 001 = Port 1 010 = Port 2 011 = Port 3 100 = Port 4 101 = Port 5 110 = Port 6 111 = No local			0 = Not at reference 1 = At reference

## Schneider-Electric adaptation

Bit 7	Bit 6	Bit 5	Bit 4	Bit 3	Bit 2	Bit 1	Bit 0
Fault	Alarm	Decelerating	Accelerating	Actual direction	Command direction	Running	Enabled
0 = No fault 1 = Fault	Not used	0 = Not decelerating 1 = Decelerating	0 = Not accelerating 1 = Accelerating	0 = Reverse 1 = Forward	0 = Reverse 1 = Forward	0 = Not active 1 = Active	0 = Not enabled 1 = Enabled

Bit 15	Bit 14	Bit 13	Bit 12	Bit 11	Bit 10	Bit 9	Bit 8
Setpoint source				Control source			At speed
0000 = Preset Speed 0 0001 = Preset Speed 1 0010 = Preset Speed 2 (SP2) 0011 = Preset Speed 3 (SP3) 0100 = Preset Speed 4 (SP4) 0101 = Preset Speed 5 (SP5) 0110 = Preset Speed 6 (SP6) 0111 = Preset Speed 7 (SP7) 1000 = TB3 ( AI1) 1001 = Network 1010 = not used 1011 = not used 1100 = not used 1101 = not used 1110 = not used 1111 = not used				000 = Local 001 = Graphic display terminal 010 = Modbus 011 = CANopen 100 = PC-Software 101 = EtherNet/IP card 110 = Controller inside 111 = Network			0 = Not at reference 1 = At reference

**Note:** When the value of Setpoint source (bits 12, 13, 14 and 15) is Preset speed x, it means that the corresponding command is given by the assembly 103 via Setpoint select (bits 12,13 and 14) (not by the terminals).



