

Machine  truxure™

General Machine Control

Automation solutions for industrial machines

Catalogue **2014**

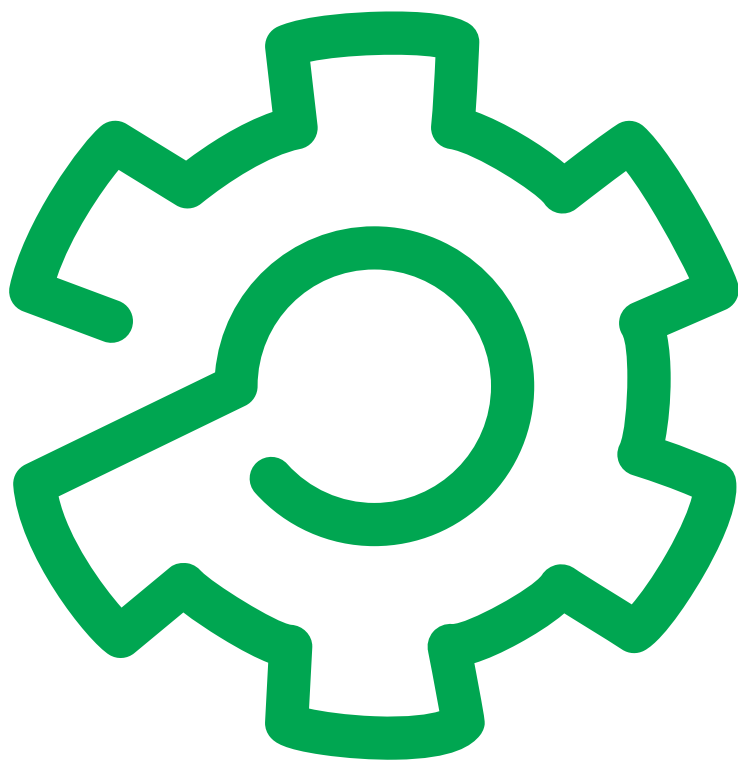

How can you fit a 6000-page catalog in your pocket ?

Schneider Electric provides you with the complete set of industrial automation catalogs all on a handy USB key for PC or in an application for tablets



Digi-Cat, a handy USB key for PC



- > Convenient to carry
- > Always up-to-date
- > Environmentally friendly
- > Easy-to-share format

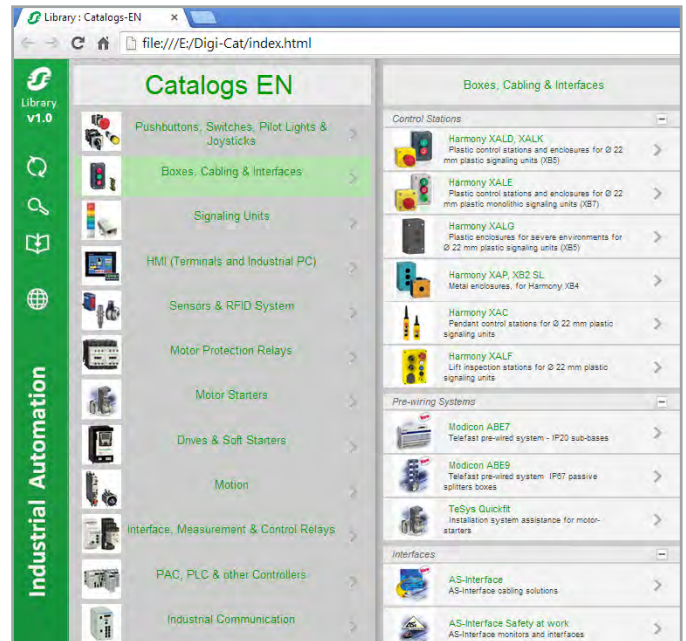

Contact your local representative to get your own Digi-Cat



e-Library, the app for tablets

If you have an iPad®:

- > Go to the App Store and search for e-Library
- > or scan the QR code



If you have an Android tablet:

- > Go to the Google Play Store™ and search for eLibrary
- > or scan the QR code

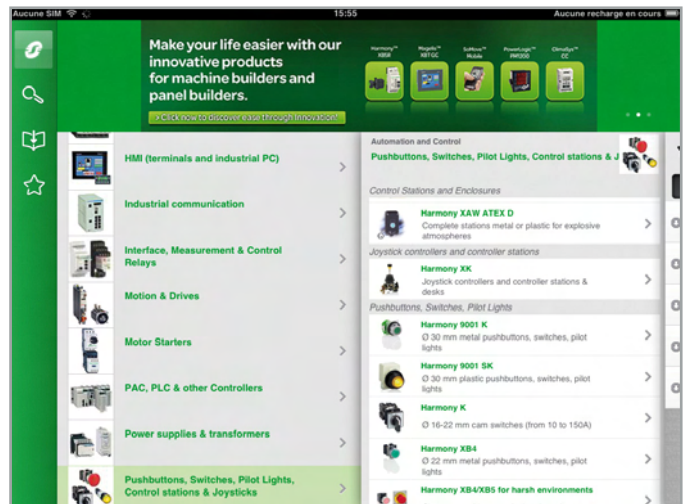

General contents

Automation solutions for industrial machines

| | |
|---------------------------------|---|
| General presentation..... | 1 |
| Hardware control platforms..... | 2 |
| I/O extension modules..... | 3 |
| Communication..... | 4 |
| SoMachine Software..... | 5 |
| Machine safety..... | 6 |
| General Motion control..... | 7 |
| Related products..... | 8 |
| Product reference index..... | 9 |

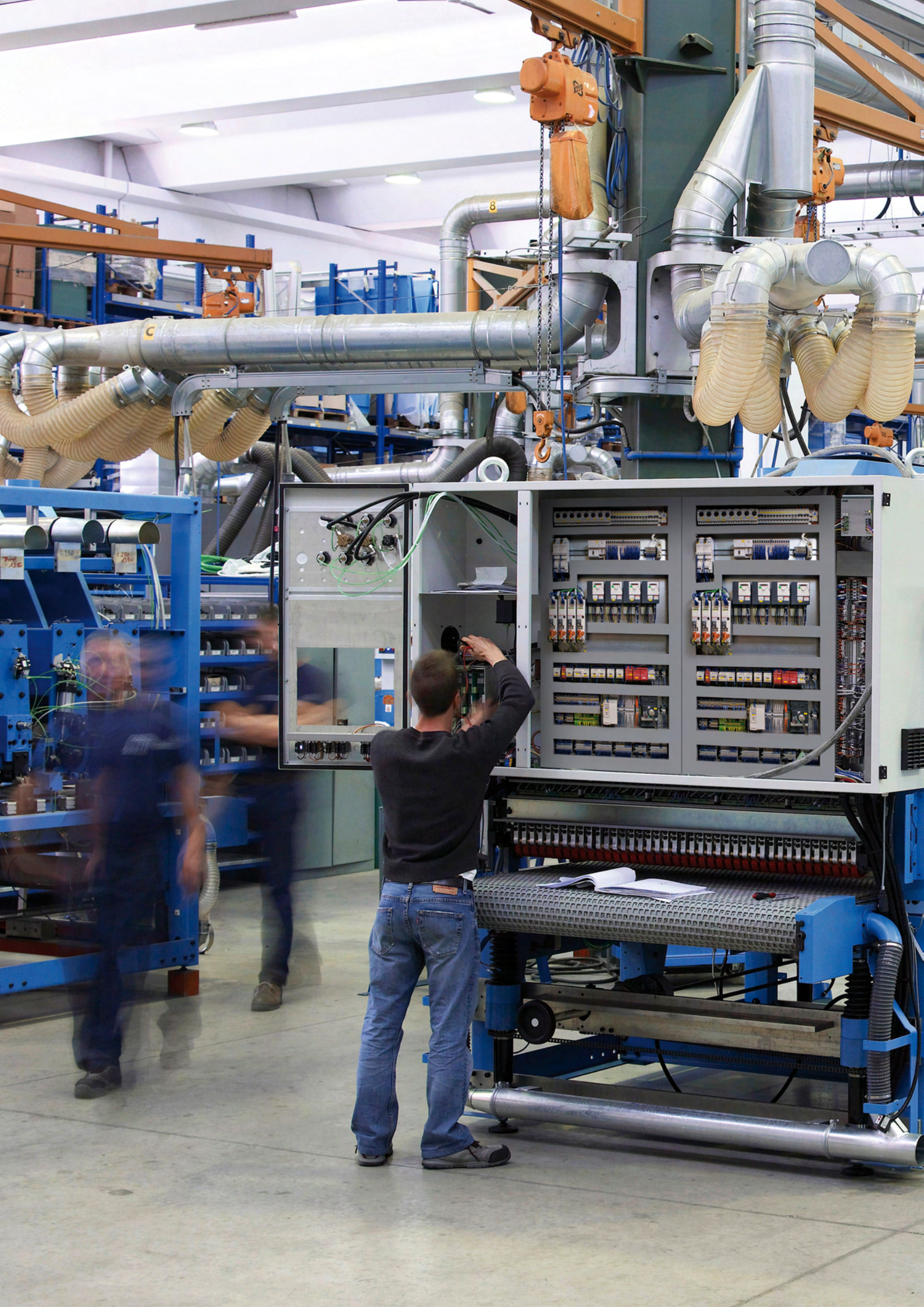

MachineStruxure™

Meet your challenges with MachineStruxure™

Schneider Electric is one of the world's leading machine automation solution providers, and with MachineStruxure we have designed a total solution consisting of technology, engineering support, and a wide range of services that help machine builders meet their challenges.

Reduce time-to-market

- > Building new machines quickly is the key to success. Engineering concepts should be easy to learn and require a minimum of training in order to reduce programming and configuration time. Ready-to-use-architectures, programming templates, and off-the-shelf software are the pillars of our high quality solutions.

Increase profitability

- > Machines don't just have to be innovative, they must also be cost-effective to build. To increase profitability you need products and solutions with all essential functionalities embedded so that there are no costly interfaces to add and no time-consuming extra functions to integrate.

Improve efficiency

- > Efficiency has become a key concept loaded with implications for energy efficiency, cost-efficient automation solutions, and efficient engineering. With performance that is the benchmark in the industry, you can improve your efficiency with complete automation solutions based on compatible software, controller, motion and safety technologies. Specific energy-efficiency functions are also available for measuring and monitoring electrical consumption.

Simplify integration and maintenance

- > Today, machines are integrated in production lines as well as in vertical information flow. Communication with machines and access to diagnostic data through the Internet and mobile devices has become standard. Spare parts must be fast and easy to replace for increased machine availability. Standardized interfaces and web protocols simplify the implementation of information flow.

chapter 1

General

presentation

- One partner for complete solutions 1/2
- A single, fully embedded solution 1/3
- Technology and services
for automating the entire machine 1/4
- The new future-proof controller range 1/6
- Embedded safety in Modicon controllers 1/7
- Tested, Validated, Documented Architectures (TVDAs) .. 1/7
 - Optimized automation architecture 1/8 to 1/10
 - Performance automation architecture 1/11
- Expertise across the entire packaging process 1/12
- Scalability -
a great asset for automating material working 1/13
- Standardized architectures
for all hoists and cranes 1/14
- Material handling -
solution packages including mechatronics 1/15
- Leader in energy -
efficient solutions for HVAC & R machines 1/16
- Pumping -
standing out from the competition with
unique selling propositions in pumping 1/17

One partner for complete solutions

As a global specialist in energy management, Schneider Electric offers integrated solutions across multiple market segments, including leadership positions in Utilities & Infrastructures, Industry & Machine automation, Data Centers & Networks, and in Residential. Focused on making energy safe, reliable, efficient, productive and green, Schneider Electric delivers complete solutions for manufacturing and process industries.

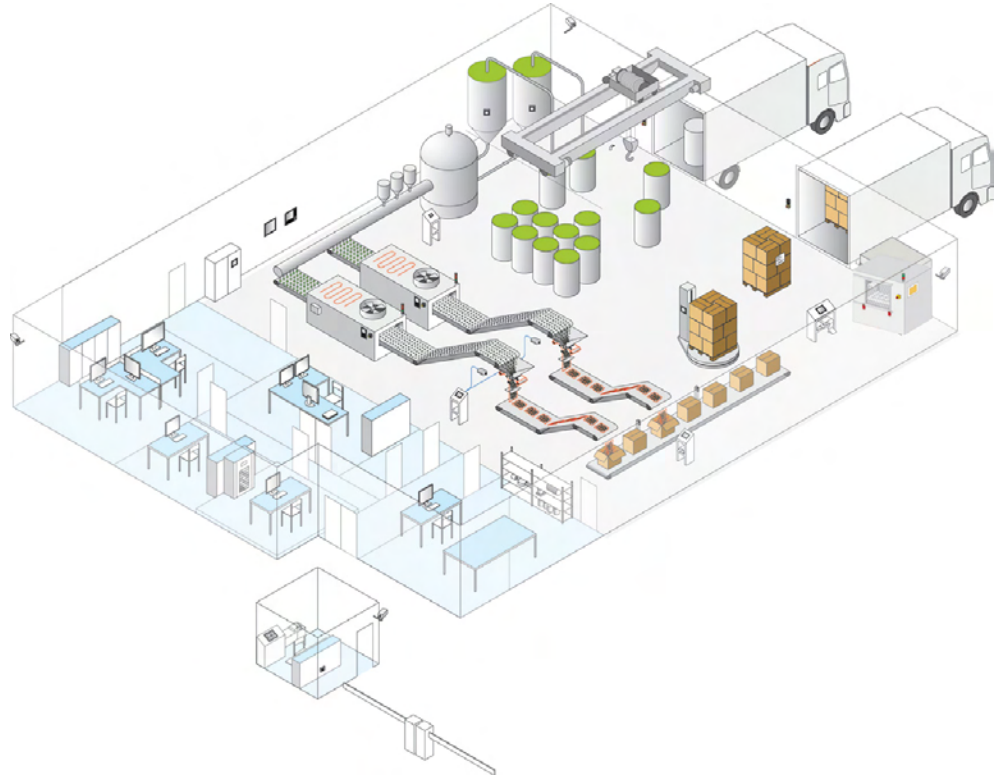

A fully embedded portfolio of solutions: PlantStruxure and MachineStruxure allow the scalable automation of processing systems, individual production machines, and entire production lines; EcoStruxure is an approach to creating an intelligent energy management system within your facility/ factory.

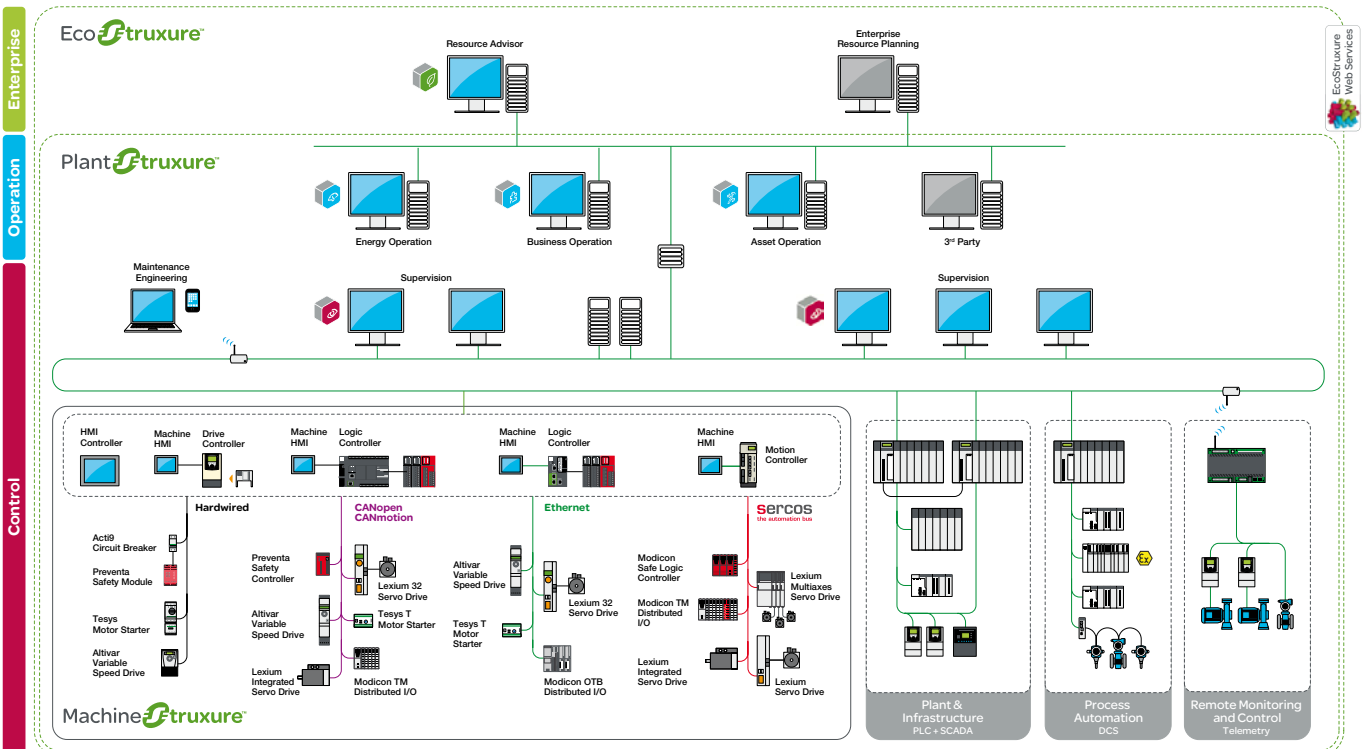

A single, fully embedded solution

- > Within MachineStruxure, Schneider Electric has included both hardware and software products as well as the full scope of its industry know-how and services covering a wide range of applications, including: packaging, hoisting, HVAC & R, pumping, material working, and material handling.
- > The guiding principle behind MachineStruxure is the flexible and scalable automation of machines, using functionally adaptable control technology embedded in a standardized, platform-neutral environment of software and components. And SoMachine is the single software environment that puts it all together, regardless of whether the machine is driven through logic, HMI, drive, motion, or safety controllers, and at any level of performance.
- > A broad portfolio of components for drives, HMI, I/O, and fieldbus interfaces, as well as a variety of electrical components, provide the framework for complete system solutions with MachineStruxure. Machine builders can use the same peripherals for designs ranging from simple machines to robot-assisted, high-performance demanding systems. Additional services constitute the framework for a partnership around the entire machines lifecycle.

The Next generation of MachineStruxure will help you design machines and systems for today and tomorrow that can reduce time to market, improve design efficiency and simplify the integration and maintenance of your machines whilst increasing your profitability.

General presentation

Technology and services for automating the entire machine

1

Technology and services for automating the entire machine

The Next generation of MachineStruxure will help you design machines and systems for today and tomorrow that can **reduce time to market, improve design efficiency and simplify the integration and maintenance** of your machines whilst **increasing your profitability**.



Machine control hardware platforms

Flexible & scalable machine control

Automation hardware with flexible & scalable performance

- > Flexible & Scalable Machine Control is the technological core of MachineStruxure. The drive, HMI, logic, and motion controllers are suitable for a wide range of machines. They also provide specific functions for Packaging and Material Handling – with and without robotics – as well as Material Working, Hoisting, HVAC & R and Pumping applications. With safety controllers for hardwired and embedded safety network solutions, requirements according to common safety standards can be met.
- > SoMachine includes all tools for the entire life cycle of machinery automated with MachineStruxure addressing every aspect of project processes: standard and safe programming, drivetrain design, HMI, commissioning, diagnostics, and data handling. Whatever you need, SoMachine is one of the most modern and powerful tool concepts on the market.

Architectures & engineering intelligence

Solution concepts for efficient engineering

- > A wide range of machine concepts can be mapped using ready to use architectures - the TVDAs (Tested, Validated and Documented Architectures). TVDAs include system user guides, CAD files, and references to available software Application Function Blocks (AFBs) to show users how they can specifically benefit from Schneider Electric's comprehensive application know-how.

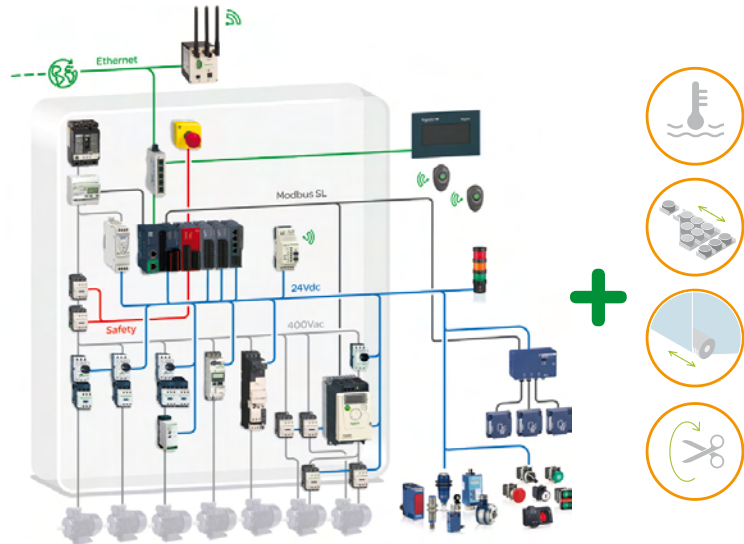
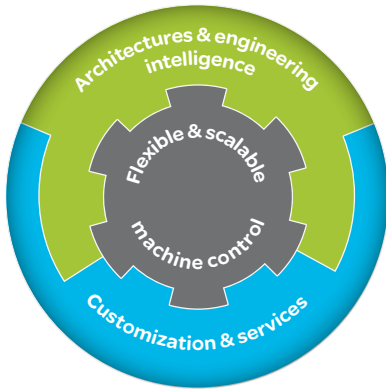

TVDA example and Application Function Blocks

- > The modular engineering approach in mechanics, electronics and software is our way to reduce design complexity. SoMachine provides a competitive edge by reducing this complexity through standardized, modular programming in globally accepted languages with templates, and proven, documented off-the-shelf application libraries. MachineStruxure has also set new standards for graphical programming and automatic code generation in the background.

3. Customization & services

Partnership throughout the entire machine lifecycle

- > Providing expertise throughout the machine lifecycle, Schneider Electric can help you grow your business and make it more profitable. We help you design your machine, speed up engineering processes, and provide you with on-site assistance.
- > In close collaboration, we can help you manage entire software engineering processes. Standard, completely pre-assembled, pre-wired, and ready-for-connection cabinets speed up the assembly process. Or, if you have special requirements, discuss customization with our Solution Service. Global standard support, 24/7 hotline services, and replacement parts centers around the world enable you to achieve greater customer satisfaction.
- > With employees in more than 100 countries, Schneider Electric serves its international customers throughout the world and meets the needs of its individual markets.

Reduce your time to market with intuitive automation

- > Tools for intuitive programming and simulation accelerate the engineering process while easy navigation and greater transparency saves you time. But intuitive automation is more: Adapting the user interface to individual user habits reduces the training required when using MachineStruxure for the first time. When working with transparent and well-arranged ready-to-use-architectures or template structures, the goal always stays clearly in sight. Make it as simple as possible, focus yourself with full attention on the task and not on the tools. MachineStruxure paves the way!

All the embedded features and functions you need to design and build machines more profitably

- > No additional interfaces, no additional effort for integration: Ethernet, communications ports, SD card and much much more is now embedded, even in simple controllers for hardwired solutions. A wide range of expansion modules or ready-to-use-solutions for energy monitoring and management allows you to create your solution with minimal effort. Thanks to open fieldbus standards and an integrated PTO interface, drive solutions can be easily implemented creating an optimal solution that saves you time and money.

Improve efficiency with flexible and scalable performance

- > Optimized, cost-effective automation: every HMI, drive, logic and motion controller delivers flexible and scalable performance. Easy upgrade to higher performance platforms through reuse of software is key to flexibility. Scalable safety performance according to IEC 61508 and EN/ISO13849 is available for hardwired architectures as well as for high-performance solutions with embedded safety networks. A wide range of drives allows you to create smart positioning systems with PTO up to multi-axes solutions with 99 fully-synchronized servo axes.

Simplify integration and maintenance - be connected everywhere!

- > Ethernet, wireless access, web servers: with MachineStruxure you are connected everywhere! Vertical availability of production and status information becomes standard, even for simple applications. The same holds true for remote control and diagnostics. Therefore, Ethernet TCP/IP and IP are now standard even on the smallest controllers. Wireless access through mobile devices and web protocols like HTTP or FTP pave the way for access to your machine from anywhere, at any time.

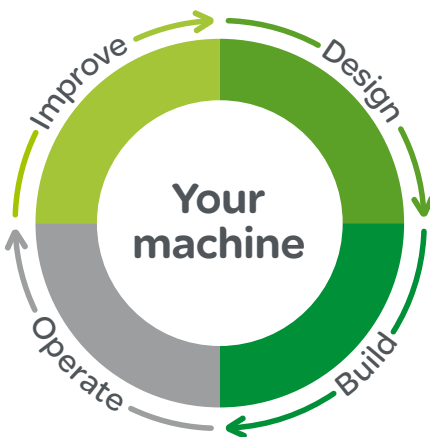

General presentation

The new future-proof controller range

Intuitive programming with SoMachine

1

The new future-proof controller range

The new range of **Modicon™ controllers** extends the hardware core of MachineStruxure. The Modicon M221 controller for hardwired solutions, the Modicon M241 for performance-demanding applications, and the Modicon M251 for distributed architectures provide the basis for scalable logic control performance. Ethernet, mini USB for programming, web server – they're all included and provide a high standard of connectivity without the need for additional options. The Modicon M221 and Modicon M241 have built-in I/O and PTO on the drive side. Modicon TM3 I/O systems can be added to all controllers through an embedded, extremely fast expansion bus.



- > The **Modicon M221** offers tremendous versatility. Available also in book format, the controller is designed for compact solutions and requires minimal installation effort. Connect a simple remote operator panel for instant maintenance and machine visualization.



- > The **Modicon M241** features CANopen communication and delivers a truly outstanding level of performance in its class. Multiple communication modules connected via the new **Modicon TM4** communication bus can further extend connectivity, for example Profibus slave.



- > With its integrated switch, the **Modicon M251** controller can communicate via two Ethernet lines as well as use all options for the controller range such as flexible I/O configurations. This allows you to build modular and distributed machine configurations.

Whether it is for initial installation or service, data and firmware handling is extremely easy on all controllers.

- > Standard embedded SD card slot simplifies program transfers and machine duplication.
- > Program download to unpowered controllers, even those still in their boxes, is achieved through the USB port.
- > QR codes printed on the devices simplify product identification, whether they are in the storage rack or installed in the field.

SoMachine is the universal programming software for machines automated by MachineStruxure controllers. Simple navigation that requires only a few clicks delivers a more efficient engineering process.

But who says that these programs all have to be engineered using the same program editor regardless of their complexity?

Therefore, we offer SoMachine Basic, a simplified engineering tool for the new Modicon M221. All programming, visualization, and commissioning are handled in just one intuitive tool that is available as a free download. No training required!

Intuitive programming with SoMachine



SoMachine Basic Software

General presentation

Embedded safety in Modicon controllers Tested, Validated, Documented Architectures (TVDA's)

1

Embedded safety in Modicon controllers

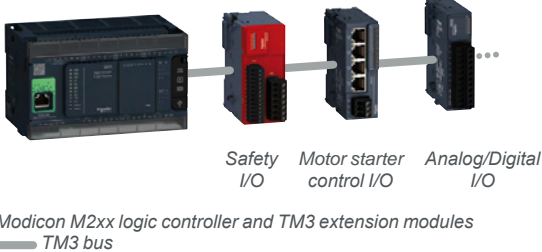

- > With the Next generation of MachineStruxure, machine safety has taken a giant step forward. The embedded safety feature is completely new and unique in its class of controllers. It is modular and based on the **Modicon TM3** expansion bus that replaces previous requirements for compact safety relays or safety controllers. Safety modules can be docked on the controller in mixed configurations with Modicon TM3 standard modules. Each module is integrated in the communication system through the expansion bus. Alternatively, you can use remote installations in the form of safety islands that you connect to the Modicon TM3 of the controller through safety buses and communication modules
- > The modularity of the new safety offer features optimum scalability of safe logic functionality allowing you to choose the precise amount of I/O needed for the application, whilst noticeably decreasing installation time. Function modules, such as the safety speed control unit with embedded advanced drive control and modules for different types of presses, provide fast, standards-compliant implementation of security functions. Program data for the modular safety controller is stored on SD cards to add the benefit of open data transfers.
- > For motion controller-based applications with PacDrives, embedded safety has long been standard. Secure and standard communication run in parallel across the sercos automation bus. In addition to existing functions, new advanced functions like Safe Torque Off (STO) and Safe Stop 1 (SS1) are now available for implementation, such as Safe Stop 2 (SS2), Safe Operating Stop (SOS), Safe Limited Speed (SLS), and monitoring Safe Direction (SDI).

Template programming - originally developed as an industry solution

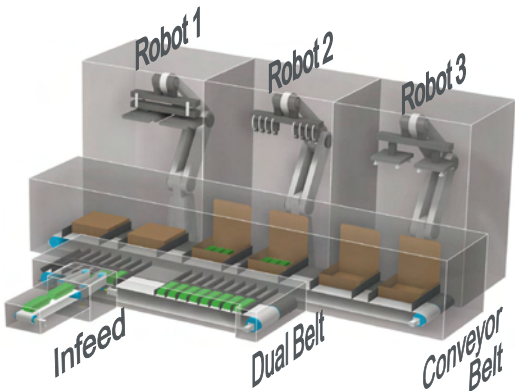

- > Complex servo applications with multiple axes or even integrated robots require software strategies to reduce complexity. Originally developed for packaging machines, the IEC 61131-compliant programming template has proven its qualities in other areas as well, including material working machines. Nevertheless, the template-based programming concept of Schneider Electric represents concentrated know-how in packaging technology.
- > With implemented OMAC-compliant operation modes, libraries with application function blocks for typical applications in the Food & Beverage industry and a Robotics Library for all current kinematics, the user receives long-standing, application know-how obtained at the highest level.

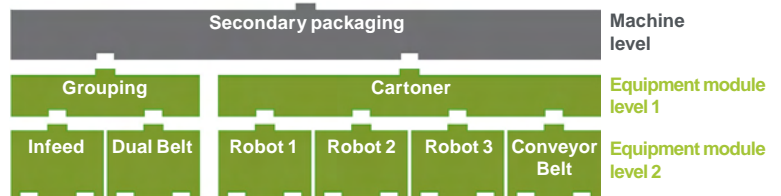

Tested, Validated, Documented Architectures (TVDA's)

Tested, Validated, Documented Architectures (TVDA's) - provide a foundation for the design of machines in many different applications. Each generic TVDA's can be adapted to a broad range of machines.

- > With hardware lists (BOM) and CAD files, they provide added value all the way from machine design and engineering on through to installation and documentation.
- > A system user guide refers to all needed steps for setup and commissioning of the automation system. In addition provides detailed support on required system adaptations.

Optimized / Performance automation architectures: see pages 1/8 to 1/11

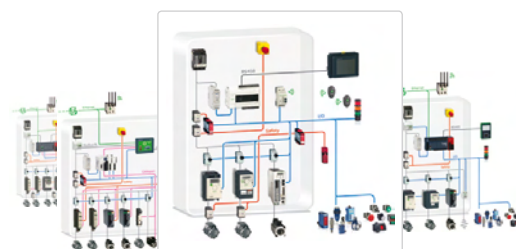

With hardware lists and CAD files such TVDA's are bridging from design / engineering to installation and documentation. A listing refers to all needed library software function blocks for realizing the machine functions.

1

Optimized automation architectures...



Powerful straight forward architecture with hardwired motion and embedded safety

✓ ... for compact and small to medium size control applications

Compact / Hardwired / logic controller **Modicon M221**

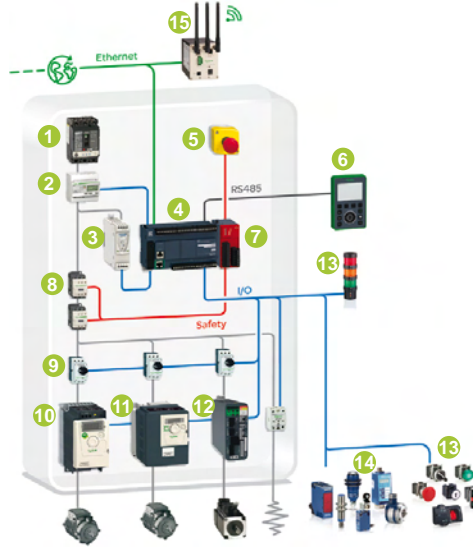

Solution breakdown

- | | |
|--|---|
| 1 Circuit breaker Compact NSX | 9 Magnetic circuit breaker TeSys GV2L |
| 2 Energy meter IEM32 | 10 Variable speed drive Altivar 12 |
| 3 Switch mode power supply Phaseo | 11 Variable speed drive Altivar 312 |
| 4 Logic controller Modicon M221 | 12 Servo Drive Lexium 28 |
| 5 Emergency stop Harmony XALK | 13 Control & Signalling units Harmony |
| 6 Graphic display TMH2GB | 14 Proximity & photoelectric sensors, limit switch, encoder OsiSense |
| 7 Safety module Modicon TM3 | 15 Wireless Ethernet access ConneXium |
| 8 Switch disconnector fuse TeSys | |



Extremely compact HMI controller solution providing flexibility with fieldbus application

✓ for machines demanding control systems with optimized space requirements

Compact / CANopen / HMI Controller **SCU**

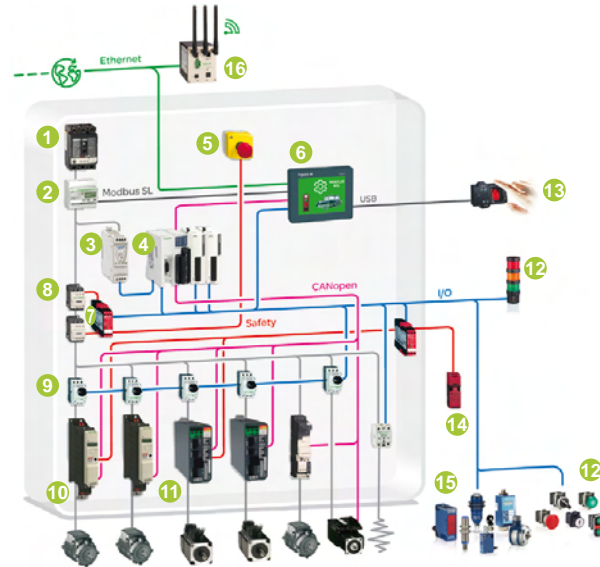

Solution breakdown

- | | |
|---|---|
| 1 Circuit breaker Compact NSX | 9 Magnetic circuit breaker TeSys GV2L |
| 2 Energy meter IEM32 | 10 Variable speed drive Altivar 32 |
| 3 Switch mode power supply Phaseo | 11 Servo Drive Lexium 28 |
| 4 Distributed IO expansion Modicon OTB , IO modules Modicon TM2 | 12 Control & Signalling units Harmony |
| 5 HMI controller Magelis SCU | 13 Biometrical switch Harmony |
| 6 Emergency stop Harmony XALK | 14 Safety switch Preventa |
| 7 Safety module Preventa XPS | 15 Proximity & photoelectric sensors, limit switch, encoder OsiSense |
| 8 Switch disconnector fuse TeSys | 16 Wireless Ethernet access ConneXium |

Optimized automation architectures...



Motion optimized solution
30% less costly compared
to conventional
PLC systems

✓ ... for drive centric applications requiring flexibility

Compact / CANopen / Drive Controller **ATV IMC**

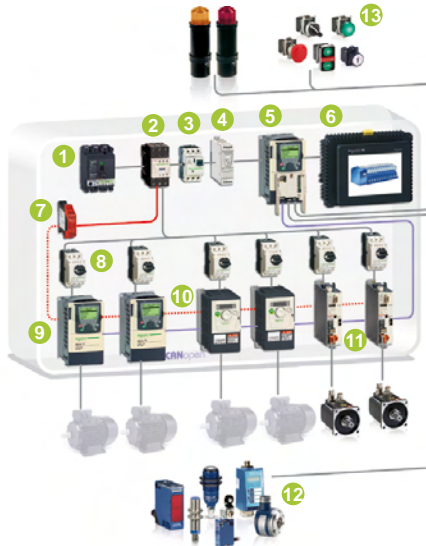

Solution breakdown

- | | |
|--|---|
| 1 Circuit breaker Compact NSX | 8 Magnetic circuit breaker TeSys GV2L |
| 2 Contactor TeSys D | 9 Variable speed drive Altivar 71 |
| 3 Circuit breaker TeSys GV2L | 10 Variable speed drive Altivar 312 |
| 4 Switch mode power supply Phaseo | 11 Servo Drive Lexium 28 |
| 5 Drive controller Altivar IMC | 12 Proximity & photoelectric sensors, limit switch, encoder OsiSense |
| 6 HMI Magelis STU | 13 Control & Signalling units Harmony |
| 7 Safety module Preventa XPS | |



Extremely compact and
powerful solution
providing embedded
safety, openness and
flexibility

✓ ... for medium to large applications requiring a scalable “all embedded” PLC design

Compact / CANopen / Logic Controller **Modicon M241**

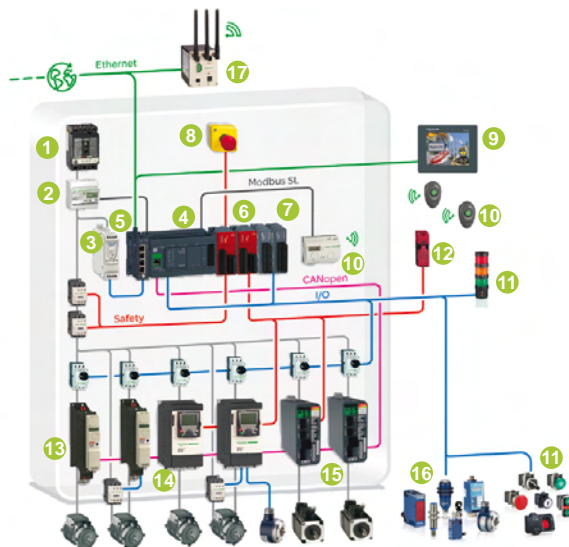

Solution breakdown

- | | |
|---|---|
| 1 Circuit breaker Compact NSX | 10 Wireless-batteryless pushbutton & configurable access point Harmony |
| 2 Energy meter IEM32 | 11 Control & Signalling units Harmony |
| 3 Switch mode power supply Phaseo | 12 Safety switch Preventa |
| 4 Logic controller Modicon M241 | 13 Variable speed drive Altivar 32 |
| 5 Ethernet switch module Modicon TM4 | 14 Variable speed drive Altivar 71 |
| 6 Safety module Modicon TM3 | 15 Servo Drive Lexium 28 |
| 7 IO expansion module Modicon TM3 | 16 Proximity & photoelectric sensors, limit switch, encoder OsiSense |
| 8 Emergency stop Harmony XALK | 17 Wireless Ethernet access ConneXium |
| 9 HMI Magelis STU | |

Optimized automation architectures...

✓ ... for distributed automation systems requiring openness and flexibility

Distributed / Modbus TCP / Logic Controller **Modicon M251**

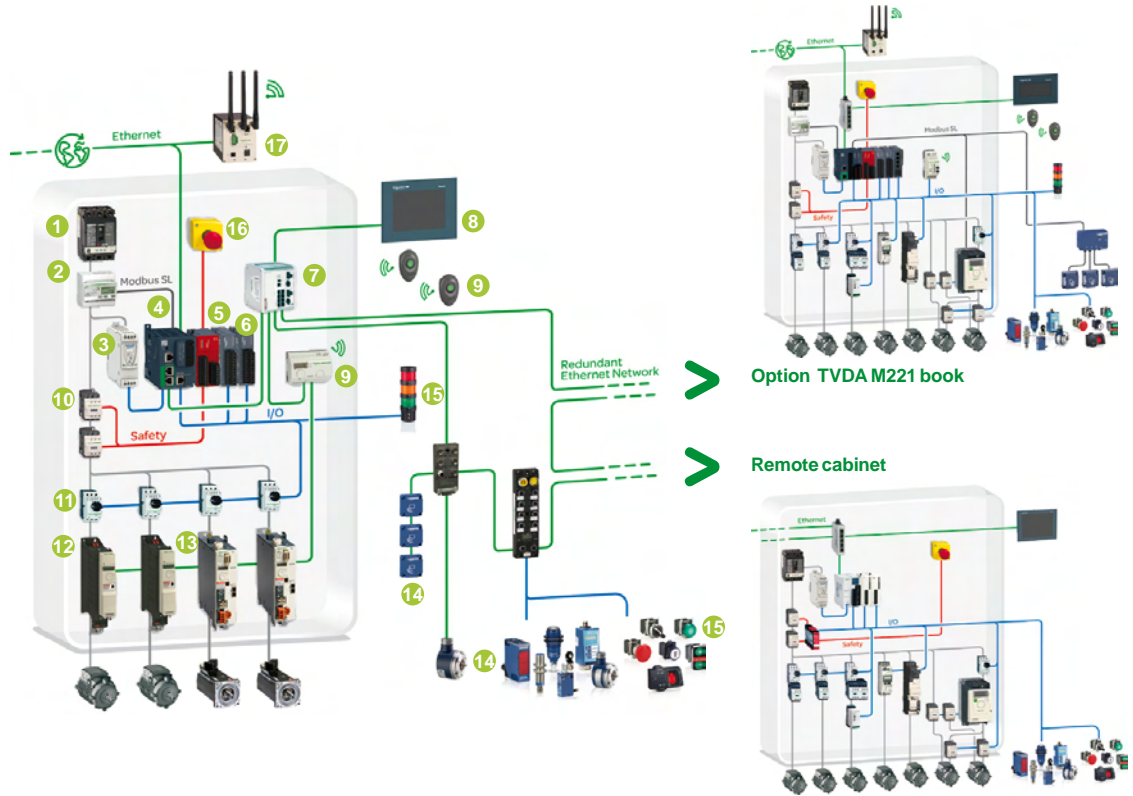

Option TVDA M221 book

Remote cabinet



Highly flexible and powerful Ethernet solution for centralized and de-centralized control

Solution breakdown

- 1 Circuit breaker **Compact NSX**
- 2 Energy meter **IEM32**
- 3 Switch mode power supply **Phaseo**
- 4 Logic controller **Modicon M251**
- 5 Safety module **Modicon TM3**
- 6 IO expansion module **Modicon TM3**
- 7 Ethernet hub **ConneXium**
- 8 HMI **Magelis HMIGTO**
- 9 Wireless-batteryless pushbutton & configurable access point **Harmony**
- 10 Switch disconnector fuse **TeSys**
- 11 Magnetic circuit breaker **TeSys GV2L**
- 12 Variable speed drive **Altivar 32**
- 13 Servo Drive **Lexium 28**
- 14 Proximity & photoelectric sensors, limit switch, encoder **OsiSense**
- 15 Control & Signalling units **Harmony**
- 16 Emergency stop **Harmony XALK**
- 17 Wireless Ethernet access **ConneXium**

Performance automation architecture...

✓ ... for medium to large applications requiring performance and high precision motion

Compact / Sercos / Motion Controller **LMC078**

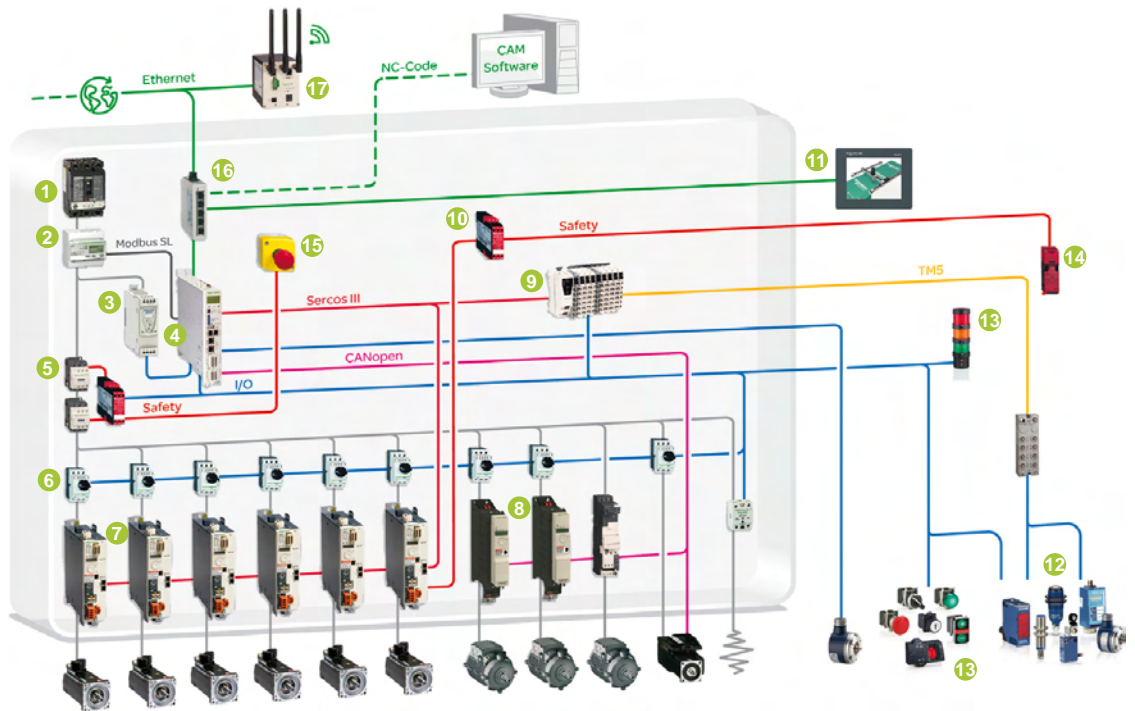

Advance control solution combining performance motion and field bus capabilities

Solution breakdown

- | | |
|--|--|
| <ul style="list-style-type: none"> 1 Circuit breaker Compact NSX 2 Energy meter IEM32 3 Switch mode power supply Phaseo 4 Motion controller Modicon LMC078 5 Switch disconnector fuse TeSys 6 Magnetic circuit breaker TeSys GV2L 7 Servo Drives Lexium 32i 8 Variable speed drives Altivar 32 9 sercos interface module Modicon TM5 10 Safety module Preventa XPS | <ul style="list-style-type: none"> 11 HMI Magelis HMIGTO 12 Proximity & photoelectric sensors, limit switch, encoder OsiSense 13 Biometric push button, Control & Signalling units Harmony 14 Safety switch Preventa 15 Emergency stop Harmony XALK 16 Switch Ethernet ConneXium 17 Wireless Ethernet access ConneXium |
|--|--|

1

Expertise across the entire packaging process



In packaging automation, Schneider Electric is one of the leading companies worldwide. As a pioneering member of OMAC, Schneider Electric has been active for many years in the OMAC Packaging Workgroup. Schneider Electric has also implemented the guidelines of the Weihenstephan Standard, which is becoming increasingly important for the vertical integration of data streams generated from packaging lines.

More than 100,000 machines worldwide are automated today with the prestigious Modicon controllers and PacDrive platforms. Everything is possible, from simple positioning applications up to 99 synchronous driven servo axes or integrated robots.

To save time and enhance quality, standard machine concepts can be automated with TVDAs and matching library software modules. For complex applications, the template-based software strategy was developed with advanced software function blocks. This supports the trend to modular machines with standardized, reusable machine programs due to the trend in packaging automation.

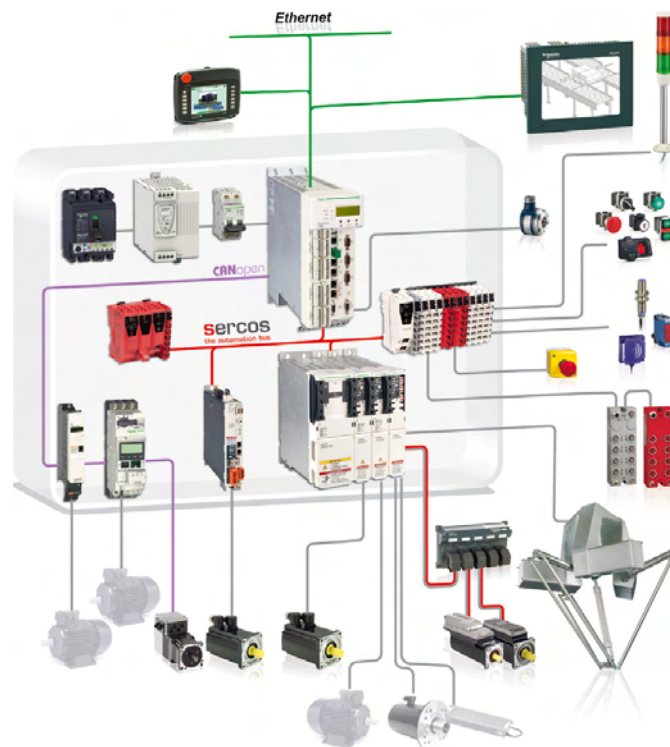

Motion control-based automation architecture for 2 to 99 synchronized servo axes and / or robotics, safety-related and standard communication run on a common automation bus. If only coordinated axes are sufficient, alternatively for many machine concepts, Logic and drive-controller-based architectures are available.



More information in our "Motion centric machine automation with PacDrive 3" catalogue

General presentation

Scalability - a great asset for automating material working

1

Scalability – a great asset for automating material working



Thanks to the wide range of controller hardware included in the MachineStruxure solution, Schneider Electric has extensive experience with material working machines. Applications range from simple bending machines or presses to multi-axis material working machines. Even NC applications such as laser-welding machines or cutting plotters with up to three interpolated axes can be realized with standard Modicon motion controllers from MachineStruxure.

TVDA significantly shorten the process from design to documentation for many types of basic applications. In addition to TVDAs, our material working library, with function blocks such as “Flying shear” or “Rotary knife” for motion control, further reduce programming effort and time to market. Complex applications like material working or assembly can be mapped using template-based, modular software structures for maximum efficiency. Lexium servo drives are suitable also for many torque and linear motors available on the market and increase the flexibility for machine design.

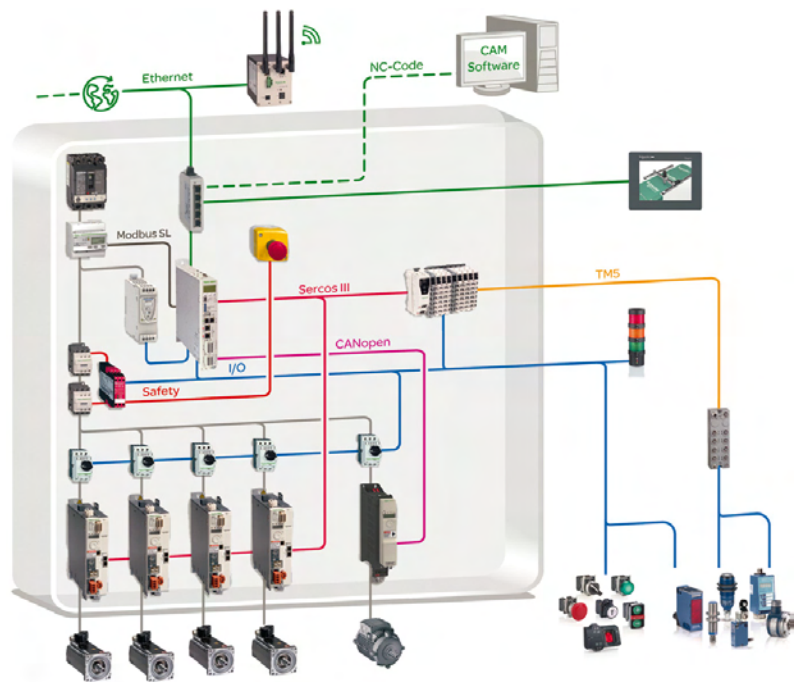

Architecture with motion controller and servo drives. Suitable for material working machines with synchronized axes or NC-machines with up to three interpolated axes. If Logic functionality is sufficient, MachineStruxure offers a variety of Modicon PLCs and motion controllers. Each application has the right balance of performance, functionality and cost efficiency!

General presentation

Standardized architectures for all hoists and cranes

1

Standardized architectures for all hoists and cranes



Whether you design industrial or construction cranes, Schneider Electric has proven solutions to enhance their productivity. And for all types TVDAs compliant to EN ISO 13849-1 and technology-specific function blocks, such as "Overload control EN 15011" or "Load over speed control" are available to reduce the time to market of your cranes while increasing their safety.

Enhanced support is delivered by our global team of experts with their unparalleled knowhow in automation and industrial machine standards. Our hoisting architectures can even help you to improve energy efficiency in your cranes while simplifying their maintenance thanks to their regenerative systems and data storage monitoring capabilities. With complete automation solutions – some even dedicated to the characteristics of local markets – and industry-specific know-how concentrated in MachineStruxure, Schneider Electric has many satisfied crane manufacturers around the world.

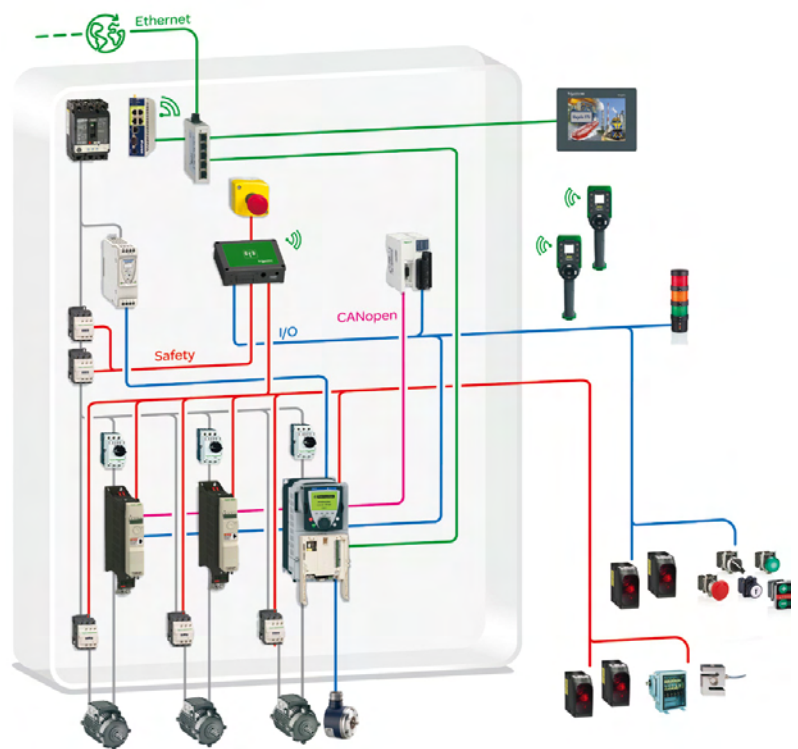

A complete ready-to-use-architecture for self-erecting cranes; related/available software functions: Data storage monitoring, wind speed control, smooth slewing, and safety solutions.

General presentation

Material handling - solution packages including mechatronics

Material handling - solution packages including mechatronics



In material handling, Schneider Electric has taken its solutions far beyond basic technologies. Logic, motion, and especially drive controllers, which are perfect for simple conveying requirements, form the hardware foundation of a wide range of tasks such as feeding, separation, or infeed. TVDAs and library functions simplify implantation of individual solutions. For demanding applications, elements like modular linear motion systems and Delta2 and Delta3 picker solutions are of particular interest. Portals based on linear motion can form the basis for material handling solutions, such as buffer for small load carriers or sorting systems for beverage. The picker provides maximum flexibility when operating with fast product flows. Right up to stainless steel robots in hygienic designs, Schneider Electric can offer complete solutions: hardware, software and mechatronics – and, of course services.

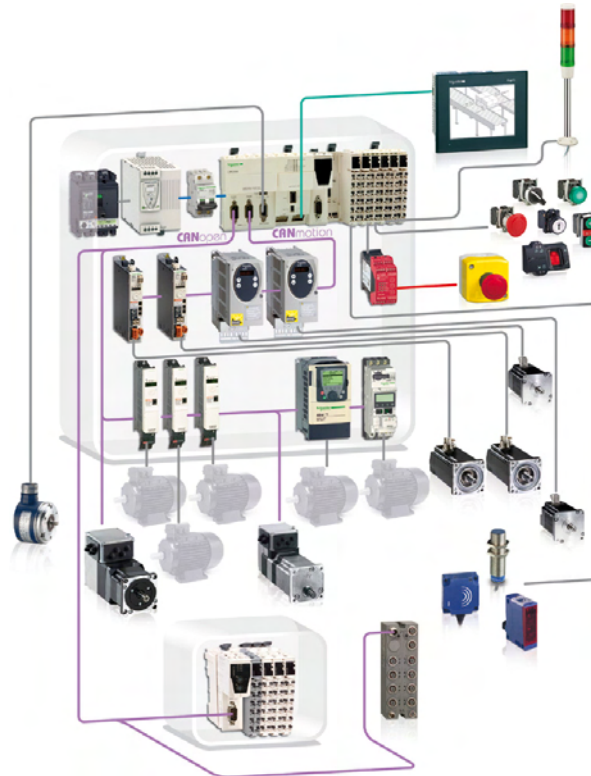

TVDA for automation solution with only a few synchronized axes, for example for linear motion portal robots.

General presentation

Leader in energy -
efficient solutions for HVAC & R machines

1

Leader in energy-efficient solutions for HVAC & R machines



There are few areas where energy efficiency plays a greater role than in HVAC & R: heating, ventilation, and air conditioning can account for over 40% of energy consumption in many buildings and facilities. From variable speed drives to power monitoring and dedicated application function blocks, MachineStruxure provides smart strategies to improve energy efficiency in small and medium air-cooled chillers, air handling units, and in solutions for large buildings or facilities.

Fieldbus interfaces like BACnet, Modbus or LonWorks and other typical communication standards for building automation solutions pave the way for integration in BMS architectures. SCADA and HMI applications enable maintenance personnel to monitor and control installations from anywhere, using just a smart phone or a tablet. With OptiM2M, a web-based machine-to-machine monitoring application, incoming machine data can be viewed remotely and analyzed at any time, from anywhere in the world.

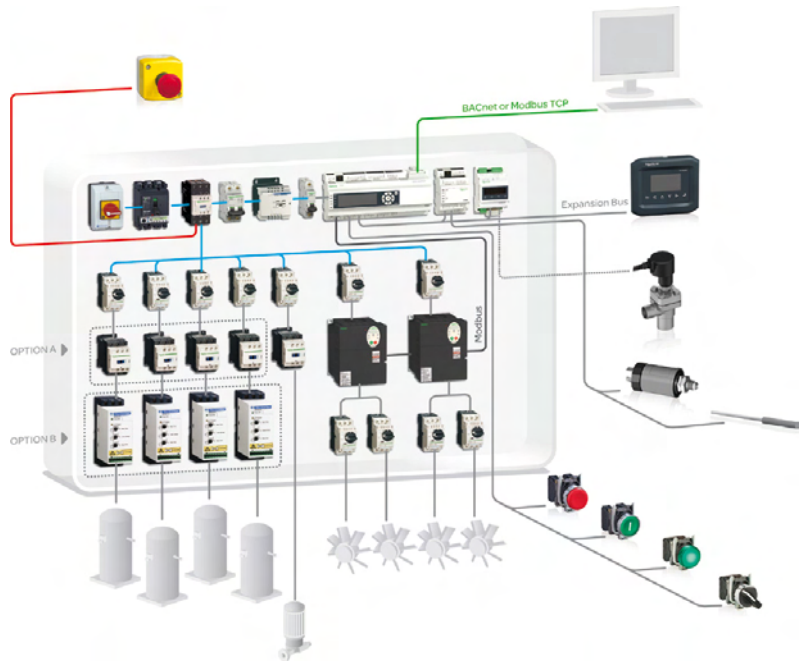

TVDA for small and medium air-cooled chillers and air-handling units. The controller, dedicated in particular for such applications, is available as a programmable logic controller with application function blocks or as a parametric logic controller with pre-loaded application programs.

General presentation

Pumping -
standing out from the competition with unique
selling propositions in pumping

1

Pumping: standing out from the competition with unique selling propositions in pumping

Water & Wastewater, commercial buildings, industry or irrigation: Schneider Electric is your one-stop-shopping partner for complete pumping solutions. Schneider Electric offers automation solutions based on flexible controller hardware and single software environments.

For pumping solutions, energy efficiency plays an important part. Much more important to machine builders, however, is their degree of freedom to differentiate themselves from competition through individual solutions. TVDAs and a new software library lay the foundation for a broad range of pumping solutions. In particular, state-of-the-art software libraries allow you to create energy efficient, individual pumping applications with clear unique selling propositions, and to get to market faster. In addition, an outstanding level of technical support is included in our MachineStruxure solutions.

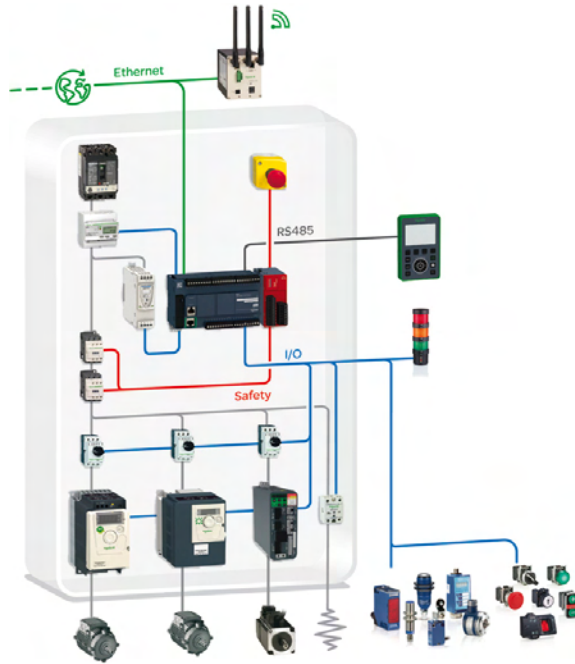

Booster multidrive architecture for typical booster solutions for fresh water supply of large buildings, e.g. hotels, office buildings, shopping malls, service areas, resorts, etc.

chapter 2

Hardware control platforms



All technical information about products listed in this chapter
are available on www.schneider-electric.com

- **Logic controllers, motion controller, drive controller and HMI controllers**
 - General selection guide* 2/2
- **Logic controllers**
 - **Modicon M221 and M221 Book**
 - General overview 2/4
 - Selection guide* 2/8
 - Presentation 2/10
 - Description 2/16
 - References 2/18
 - **Modicon M241**
 - Selection guide* 2/22
 - Presentation 2/24
 - Description 2/29
 - References 2/30
 - **Modicon M251**
 - Selection guide* 2/32
 - Presentation 2/34
 - Description 2/40
 - References 2/41
 - **Modicon M258**
 - Selection guide* 2/42
 - Presentation 2/44
 - Description 2/49
 - References 2/50
- **Motion controllers**
 - **Modicon LMC058**
 - Selection guide* 2/52
 - Presentation 2/54
 - Description 2/61
 - References 2/62
 - **Modicon LMC078**
 - Presentation 2/64
 - Description 2/67
 - References 2/69
- **Drive controller**
 - **Altivar IMC integrated controller card for Altivar 61 and Altivar 71 variable speed drives**
 - Presentation 2/70
 - Functions 2/72
 - Description 2/74
 - References 2/75
- **HMI controllers**
 - Selection guide* 2/76
 - Presentation 2/78
 - Functions 2/80
 - **Magelis™ SCU Small HMI controllers**
 - Description 2/82
 - References 2/85
 - **Magelis™ XBTGC HMI controllers, Magelis™ XBTGT, XBTGK Standard Advanced panels + control function**
 - Presentation 2/86
 - Functions 2/88
 - Description 2/90
 - References 2/92

Hardware control platforms

Logic controllers, motion controllers, drive controller and HMI controllers

| Applications | Control of simple machines | Control of simple motion control machines, Control loops | Control of machines for distributed architectures |
|--------------|----------------------------|--|---|
|--------------|----------------------------|--|---|



| | | | |
|--|---|--|---|
| Configuration software | SoMachine Basic | SoMachine | |
| Power supply | 24 V $\overline{\text{---}}$ and 100/240 V \sim | 24 V $\overline{\text{---}}$ and 100/240 V \sim | 24 V $\overline{\text{---}}$ |
| Embedded inputs (depending on model) | <input type="checkbox"/> From 8 to 24 inputs <input type="checkbox"/> 2 analog inputs 0-10 V | <input type="checkbox"/> 14 or 24 Digital Inputs | <input type="checkbox"/> None |
| Embedded outputs (depending on model) | <input type="checkbox"/> From 7 to 16 transistor source or relay outputs | <input type="checkbox"/> 10 or 16 transistor outputs (source or sink) <input type="checkbox"/> 4 transistor outputs (source) + 6 relay outputs <input type="checkbox"/> 4 transistor outputs (source) + 12 relay outputs | <input type="checkbox"/> None |
| I/O expansion (compatible offer) | <input type="checkbox"/> Modicon TM3 expansion modules (digital / analog / TeSys motor starter controller / functional safety I/Os) <input type="checkbox"/> Modicon TMC2 cartridges (analog I/O, Applications) | <input type="checkbox"/> Modicon TM3 expansion modules (digital / analog / TeSys motor starter controller / functional safety I/Os) <input type="checkbox"/> Modicon TMC4 cartridges (analog I/O, Applications) | <input type="checkbox"/> Modicon TM3 expansion modules (digital / analog / TeSys motor starter controller / functional safety I/Os) |
| Integrated functions | <input type="checkbox"/> Regulation (PID) <input type="checkbox"/> 4 High speed counters (100 kHz) <input type="checkbox"/> 2 positioning outputs: PTO (P/D with trapezoidal profile and S curve), PWM, PLS (1) | <input type="checkbox"/> Regulation (PID) <input type="checkbox"/> 8 High speed counters (200 kHz) <input type="checkbox"/> 4 positioning outputs: PTO (P/D, CW and CCW with trapezoidal profile and S curve), PWM, PLS | <input type="checkbox"/> Regulation (PID) |
| Embedded communication | Serial links RS232/RS485 | <input type="checkbox"/> 1 or 2 RJ45 ports (1) <input type="checkbox"/> 1 optional port with TMC2SL1 cartridge (1) | 1 RJ45 port and 1 screw terminal port |
| | Ethernet | 1 Network with 1 RJ45 port | 1 Network with 2 RJ45 ports (switch) or optional switch 4 ports module TM4ES4 (1) |
| | CANopen | - | Master (1) |
| | Other | - | Profibus DP: with optional module TM4PDPS1 (Slave) |
| USB mini-B programming port | | Yes, with loading application program and firmware updating functions without the controller being powered by another source | |
| Ethernet Services | Basic services | Modbus TCP communication (client & server), Modbus TCP slave, Dynamic DHCP client Configuration, Programming, downloading, monitoring | |
| | Advanced services | SMS and emails (available 4 th quarter 2014) | Updated firmware, data exchange - NGVL and IEC VAR ACCESS, WEB server, IP Ethernet adapter network management SNMP.MIB2, FTP file transfer Modbus TCP I/O scanning (1), dynamic DHCP Client Configuration, Fast Device Replacement (FDR) |
| User memory | RAM | 640 KB | 64 MB |
| | Flash | 256 KB | 128 M |
| | Option | SD card 256 MB | SD card 256 MB |
| Data logging | - | Yes | |
| Processing power | Execution speed | 0,2 μ s / boolean instructions | 22 ns / boolean instructions |
| | Program | 10 K boolean instructions | 128 K boolean instructions |
| Other | Run/Stop switch | | |
| Controller type | Modicon M221 and M221 Book logic controllers | Modicon M241 logic controllers | Modicon M251 logic controllers |
| Pages | 2/8 | 2/22 | 2/32 |

(1) Depending on product reference

| Speed control, high speed counter and motion control for coordinated axes | Speed control, high speed counter control and motion control for synchronized axes | Motion Controller for coordinated and synchronized axes | Control by integration of automation functions on Altivar 61 and Altivar 71 variable speed drives | Data control and parameter-setting IEC 1131-2 control function |
|---|--|---|---|--|
|---|--|---|---|--|



| | | | | |
|--|--|---|--|--|
| SoMachine | | | | |
| 24 V $\overline{\text{---}}$ | | | | |
| <input type="checkbox"/> 26 to 38 digital inputs <input type="checkbox"/> 4 analog inputs <input type="checkbox"/> 16 to 28 transistor outputs including 4 reflex outputs <input type="checkbox"/> Up to 12 relay outputs | <input type="checkbox"/> 16 to 28 transistor outputs | <input type="checkbox"/> 20 Digital inputs, 4 of which are capture inputs <input type="checkbox"/> 8 Transistor Outputs | <input type="checkbox"/> 10 digital inputs <input type="checkbox"/> 2 analog inputs <input type="checkbox"/> 6 transistor outputs <input type="checkbox"/> 2 analog outputs | 12 to 16 digital outputs <input type="checkbox"/> 6 to 16 transistor outputs |
| <input type="checkbox"/> Modicon TM5 expansion modules (digital / analog / expert I/Os) <input type="checkbox"/> Modicon TM7 expansion blocks (digital / analog I/Os) | | <input type="checkbox"/> Modicon TM5 and Modicon TM7 CANopen interface modules <input type="checkbox"/> Modicon TM5 Sercos III interface module and: - Modicon TM5 expansion modules (digital / analog / expert I/Os) - Modicon TM7 expansion blocks (digital / analog I/Os) | <input type="checkbox"/> Expansion card VW3A320 (digital / analog / relay / frequency control and probe I/Os) | <input type="checkbox"/> Modicon TM2 expansion modules (digital / analog I/Os) (1) |
| <input type="checkbox"/> Regulation (PID) <input type="checkbox"/> 8 High speed counters (200 kHz) <input type="checkbox"/> 4 PWM outputs <input type="checkbox"/> Position control | <input type="checkbox"/> Regulation (PID) <input type="checkbox"/> 8 High speed counters (200 kHz) <input type="checkbox"/> 4 PWM outputs <input type="checkbox"/> Position/Speed/Torque control <input type="checkbox"/> Master encoder, G Code | <input type="checkbox"/> Position/Speed/Torque <input type="checkbox"/> Master encoder, G Code <input type="checkbox"/> PID libraries / PWM | <input type="checkbox"/> 2 High speed counters (100 kHz) <input type="checkbox"/> Analog <input type="checkbox"/> Position | <input type="checkbox"/> 4 High speed counters (100 kHz) <input type="checkbox"/> 4 PWM outputs, PLS (1) <input type="checkbox"/> Display, Control, Execution, ... |
| 1 RJ45 port | 1 RJ45 port | 1 RJ45 port | - | 1 RJ45 port or 1 SUB-D 9 pin port (1) |
| 1 Network with 1 RJ45 port | 1 Network with 1 RJ45 port | 1 Network with 1 RJ45 port | 1 Network with 1 RJ45 port | 1 Network with 1 RJ45 port |
| Master (1) | Master (1) | Master/Slave | Master | Master (1) |
| Profibus DP: with optional module TM5PCDPS (1) (Slave) | Profibus DP: with optional module TM5PCDPS (1) (Slave) <input type="checkbox"/> CANmotion (Master) | <input type="checkbox"/> Sercos III bus(daisy chain) <input type="checkbox"/> Profibus DP: with optional module VW3E70400000 <input type="checkbox"/> EtherNet / IP (Adapter): with optional module VW3E70410000 | - | - |
| Yes | Yes | Yes | Yes | Yes |
| Modbus TCP communication (client & server), Modbus TCP slave, Dynamic DHCP client Configuration, Programming, downloading, monitoring | | Modbus TCP communication (client & server), Modbus TCP slave, Dynamic DHCP client Configuration, Programming, downloading, monitoring | Ethernet Modbus TCP, UDP, TCP, SNMP | Uni-TE, Modbus, Modbus TCP/IP, Parallel printer |
| WEB server, FTP server | WEB server, FTP server | NGVL data exchange, FTP file transfer, SoMachine Protocol, OPC Server, NetManage | WEB server, FTP server, Dynamic DHCP client Configuration, BOOTP server | WEB server, Web gate |
| 64 MB | 64 MB | 512 MB | 2 MB | 512 KB |
| 128 MB | 128 MB | 128 KB | 2 MB | 16 to 32 MB |
| - | - | SD card | - | CF card 128 MB... 4 GB (1) |
| Yes | Yes | Yes | Yes | Yes |
| 22 ns / boolean instructions | 22 ns / boolean instructions | 2 ns / instruction | - | - |
| 128 K boolean instructions | - | - | - | - |
| - | - | Message log, error message and time-stamping, Sercos bus scanning | - | - |
| Modicon M258 logic controllers | Modicon LMC058 motion controllers | Modicon LMC078 motion controllers | ATVIMC integrated controller card | HMISCU, XBTGC, XBTGT, XBTGK HMI controllers |
| 2/42 | 2/52 | 2/64 (Available Q2 2014) | 2/70 | 2/76 |

(1) Depending on product reference

Maximize your business and machine performance with MachineStruxure

Machine builders like you are constantly looking for new ways to design and build more innovative machines in less time and at lower cost. MachineStruxure™ can help.

The NEXT generation of MachineStruxure is a complete machine automation solution that provides flexible and scalable machine control, ready-to-use architectures, efficient engineering solutions, and comprehensive customization and engineering support services. It can help you meet your challenges for improved efficiency and greater productivity, as well as allow you to deliver higher added value to your customers throughout the entire machine life cycle.

Ready-to-use architectures and function blocks

Tested, Validated, and Documented Architectures (TVDA) are just one of the ways we help you reduce design time. Whether your machines are simple or complex, Application Function Blocks (AFBs) make system design fast and easy.

2

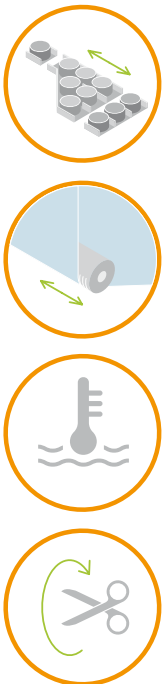
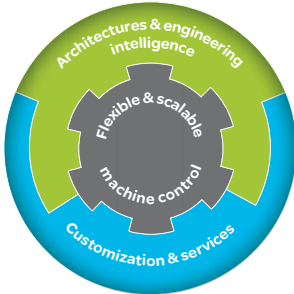

Application Function Blocks (AFB)

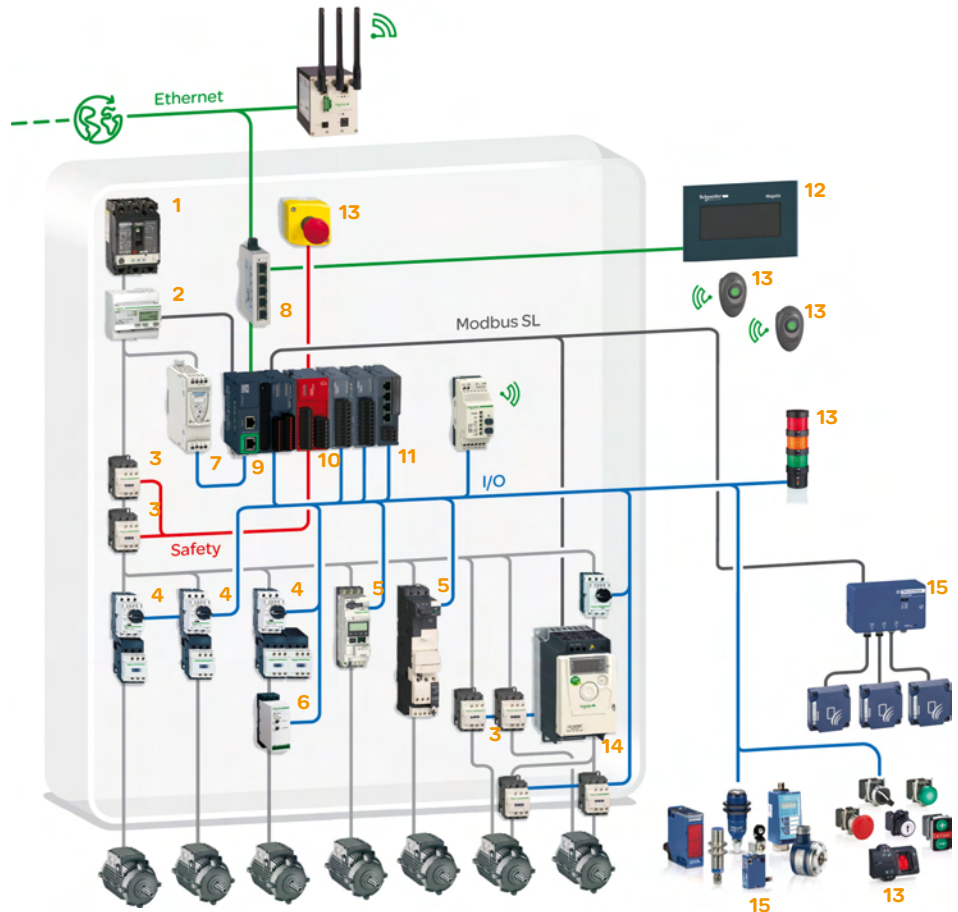

- | | |
|---|--|
| 1 POWERPACT circuit breaker | 10 Modicon TM3 safety module, Modicon TM3 digital/analog I/O modules |
| 2 Energy meter Acti9 iEM310 iEM310 | 11 Modicon TM3 TeSys motor starter module |
| 3 TeSys D contactor | 12 Magelis display |
| 4 TeSys GV2P motor circuit-breaker | 13 Harmony signalling and control devices |
| 5 TeSys U starter-controller | 14 Altivar 312 variable speed drive |
| 6 Multi9 circuit-breaker C60N | 15 OsiSense: limit switches and inductive sensors |
| 7 Phaseo power supply 24 V $\bar{\text{---}}$ | |
| 8 Ethernet switch (unmanaged) | |
| 9 Modicon M221 Book logic controller | |

Fastest and smallest logic controllers on the market

Flexible and scalable machine control

With the new range of Modicon™ logic controllers, the next generation of MachineStruxure provides flexible and scalable machine control. Ethernet connectivity, USB port for programming, and an embedded web server: it's all included.



From logic to motion control, the Modicon range offers flexibility and scalability to suit your needs

Modicon M221: the small yet powerful logic controller for hardwired solutions

Everything you need is embedded

The Modicon M221 offers best-in-class performance. Available also in book format, the Modicon M221 requires minimal installation and offers tremendous versatility.

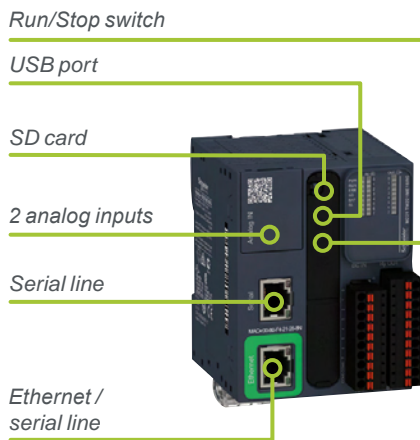

Modicon M221 Book and a broad choice of I/O extension modules

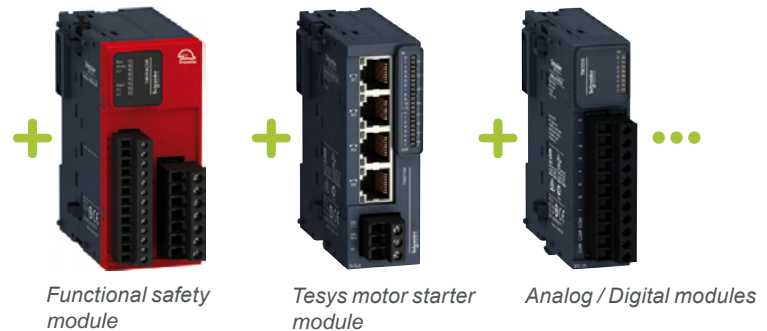

- > SD card, Run/Stop switch, USB port, 2 analog inputs, serial line, Ethernet and serial line, cartridge extension (on standard version): it's all **embedded**.
- > Thanks to its high degree of **flexibility**, it's very easy to add additional modules (safety modules, Tesys motor starter module, extensive line of analog and digital modules, ...) - and still keep everything in **just one configuration**

Modicon M221: the small yet powerful logic controller for hardwired solutions

Intuitive machine programming with SoMachine

SoMachine® is the universal programming software for machines automated by MachineStruxure controllers. Simple navigation that requires only fewer clicks delivers a more efficient engineering process.

- > In order to reduce complexity we offer SoMachine Basic, a simplified engineering tool for the new controller Modicon M221.
- > All programming, visualization, and commissioning are handled in just one intuitive tool that is available as a free download.
- > No training required

2



SoMachine simplifies every step in the design and commissioning of your machines

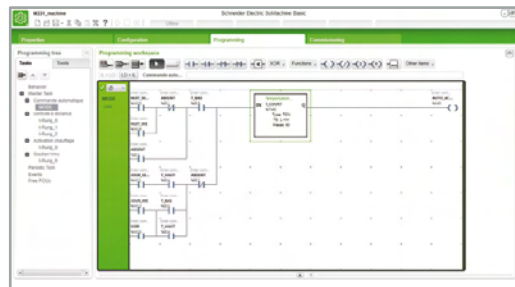

Programming

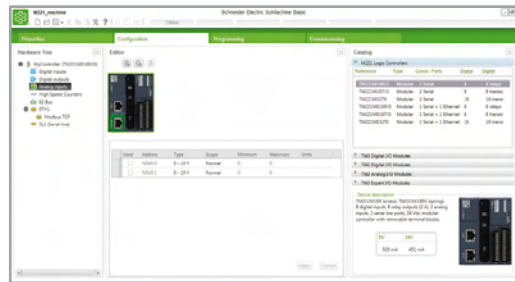

Configuration

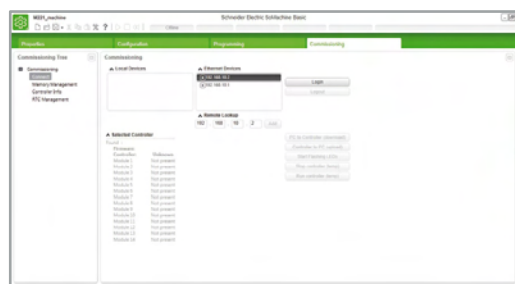

Commissioning



Connected everywhere

For simplified maintenance, commissioning, and uploads/downloads, simply use your smartphone or tablet and connect anytime, anywhere.

- > Application for mobile phone & smartphone
- > Bluetooth® communication

Customization and services

Our experts help you every step of the way, from perfecting machine design to on-site services of the finished machine. Global support, 24/7 hotline services, and replacement parts centers around the world enable you to deliver superior customer support and satisfaction.



Achieve benchmark performance
while increasing profitability



Make the most of your energySM

Hardware control platforms

Modicon M221 and M221 Book logic controllers

Applications

Control of simple machines



Supply voltage

100-240 V ~ 24 V --- 100-240 V ~ 24 V --- 100-240 V ~ 24 V ---

Inputs/outputs

16 logic I/O **24 logic I/O** **40 logic I/O**

- Logic inputs/outputs
 - No. and type of inputs
 - No. and type of outputs
 - Connection of logic I/O
- Analog inputs
 - Connection of analog inputs

| | | | | | |
|---|---|--|--|--|--|
| 9 sink/source 24 V --- inputs, inc. 4 high-speed inputs | 9 sink/source 24 V --- inputs, inc. 4 high-speed inputs | 14 sink/source 24 V --- inputs, inc. 4 high-speed inputs | 14 sink/source 24 V --- inputs, inc. 4 high-speed inputs | 24 sink/source 24 V --- inputs, inc. 4 high-speed inputs | 24 sink/source 24 V --- inputs, inc. 4 high-speed inputs |
| 7 relay outputs | 7 source transistor outputs, inc. 2 high-speed outputs | 10 relay outputs | 10 source transistor outputs, inc. 2 high-speed outputs | 16 relay outputs | 16 source transistor outputs, inc. 2 high-speed outputs |

- With removable screw terminal block
- 2 x 0...10 V analog inputs
- On dedicated removable terminal block
- 7 Modicon TM3 expansion modules, along with limited number of outputs (see page 3/24)
 - 14 Modicon TM3 expansion modules with the use of bus expansion modules (transmitter and receiver), along with limited number of outputs (see page 3/24)
 - Possible use of Modicon TM2 expansion modules with restrictions.

I/O extension

Max. number of I/O expansion modules that can be connected/with bus expansion modules

Embedded communication

- Ethernet link
- Modbus TCP communication (client & server), Modbus TCP slave, Dynamic DHCP client Configuration, Programming, downloading, monitoring
 - SMS and emails (▲)
- Serial link
- 1 serial link port (RJ 45 connector) RS232/485 with + 5 V supply

Functions

- Process control
- Counting
- Position control
- PID
- Up to 4 high-speed counter inputs (HSC), 100 kHz frequency
- On TM221C●●T and TM221CE●●T controllers only:
 - pulse width modulation (PWM)
 - pulse generator (PLS)
 - 2 P/D pulse train outputs (PTO) with trapezoidal profile and S curve (▲), 100 kHz frequency

Format

3 controller sizes:

| | | |
|---|--|--|
| 95 x 90 x 70 mm 3.74 x 3.54 x 2.75 in. | 110 x 90 x 70 mm 4.33 x 3.54 x 2.75 in. | 163 x 90 x 70 mm 6.41 x 3.54 x 2.75 in. |
|---|--|--|

Options

- Cartridges
 - 3 analog I/O expansion cartridges
 - 1 additional serial link communication cartridge
 - 3 application cartridges
 - for control of hoisting applications
 - for control of packaging applications
 - for control of conveying applications

Mounting

1 1 2

Graphic display and monitoring unit (▲)

Mounting on ┘ symmetrical rail or panel with specific mounting kit TMAM2

Software programming

With SoMachine Basic software (see page 5/6)

Logic controller type

Modicon M221

- Controllers without Ethernet port
- Controllers with embedded Ethernet port

| | | | | | |
|------------|------------|------------|------------|------------|------------|
| TM221C16R | TM221C16T | TM221C24R | TM221C24T | TM221C40R | TM221C40T |
| TM221CE16R | TM221CE16T | TM221CE24R | TM221CE24T | TM221CE40R | TM221CE40T |

Pages

2/18

▲ Available: 4th quarter 2014.

Control of simple machines



24 V --- 24 V --- 24 V ---

16 logic I/O **16 logic I/O** **32 logic I/O**

| | | |
|---|---|--|
| 8 sink/source 24 V --- inputs, inc. 4 high-speed inputs | 8 sink/source 24 V --- inputs, inc. 4 high-speed inputs | 16 sink/source 24 V --- inputs, inc. 4 high-speed inputs |
| 8 relay outputs | 8 source transistor outputs, inc. 2 high-speed outputs | 16 source transistor outputs, inc. 2 high-speed outputs |

- With removable screw terminal block or spring terminal block (1)
- 2 x 0...10 V analog inputs
- On dedicated removable terminal block
- 7 Modicon TM3 expansion modules, along with limited number of outputs (see page 3/24)
 - 14 Modicon TM3 expansion modules with the use of bus expansion modules (transmitter and receiver), along with limited number of outputs (see page 3/24)
 - Possible use of Modicon TM2 expansion modules with restrictions.

Embedded communication

- Ethernet link
- Modbus TCP (client & server), Modbus TCP slave, dynamic DHCP client Configuration, Programming, downloading, monitoring
 - SMS and emails (▲)
- Serial link
- 1 serial link port (RJ 45 connector) RS232/485 with + 5 V supply
- 1 additional serial link port on TM221M●●● controllers (RJ 45 connector) RS485

Functions

- Process control
- Counting
- Position control
- PID
- Up to 4 high-speed counter inputs (HSC), 100 kHz frequency
- On TM221M16T/TG, TM221ME16T/TG, TM221M32TK and TM221ME32TK controllers only:
 - pulse width modulation (PWM)
 - pulse generator (PLS)
 - 2 P/D pulse train outputs (PTO) with trapezoidal profile and S curve (▲), 100 kHz frequency

Format

1 size only:

70 x 90 x 70 mm
2.75 x 3.543 x 2.75 in.

Options

- Graphic display and monitoring unit (▲)
- Mounting on ┘ symmetrical rail or panel with specific mounting kit TMAM2

Mounting

With SoMachine Basic software (see page 5/6)

Modicon M221 Book

| | | |
|-----------------|-----------------|-------------|
| TM221M16R | TM221M16T | TM221M32TK |
| TM221M16RG (1) | TM221M16TG (1) | |
| TM221ME16R | TM221ME16T | TM221ME32TK |
| TM221ME16RG (1) | TM221ME16TG (1) | |

Pages

2/19

(1) Spring terminal block on references ending in the letter G.

▲ Available: 4th quarter 2014.

Compatibility of offers

Modicon M221 and M221 Book logic controllers

- > Modicon TM3 expansion modules
- > Modicon TM2 expansion modules
- > SoMachine Basic software



Modicon M221 logic controllers (standart format)
16 I/O channels



24 I/O channels



40 I/O channels



Modicon M221 Book logic controllers
16 I/O channels



32 I/O channels

Presentation

Applications

Designed for simple machines, the particularly small dimensions of Modicon **M221** and **M221 Book** logic controllers are ideal for optimizing the size of wall-mounted and floor standing control system enclosures.

- The controllers are available in 2 formats:
 - Modicon **M221** (TM221C●●●● references), give excellent connection capacity and customization options using I/O, communication or application cartridges without increasing the controller size.
 - Modicon **M221 Book** (TM221M●●● references), combine very small dimensions with a wide choice of connections.
- M221 and M221 Book controllers have an embedded Ethernet port meaning they can easily be integrated in control system architectures, for remote control and maintenance of machines by means of applications for smartphones, tablets and PCs.
- The wealth of functions embedded in M221 and M221 Book controllers minimizes the cost of the machine:
 - Functions embedded in the controller: Modbus serial link, USB port dedicated to programming and simple position control functions (high-speed counters and pulse train outputs with trapezoidal profile and S curve).
 - Functions embedded in the Modicon TM3 expansion: functional safety modules, motor-starter control module, dedicated display unit and remote expansion system.
- SoMachine Basic's programming software is intuitive, making it quick to create applications, and also has embedded configuration of the display unit and extensions, including the Functional Safety modules. This software environment makes it easy to retrieve Twido range applications, maximizing use of the investment already made. Applications can thus easily be ported to any of the Modicon logic controllers: M241, M251 and M258.

Key features

| Modicon TM221C●●● | Modicon TM221M●●● |
|--|--|
| w x h x d | |
| □ 16 I/O: 95 x 90 x 70 mm (3.74 x 3.54 x 2.75 in.) | □ 16 I/O: 70 x 90 x 70mm (2.75 x 3.54 x 2.75 in.) |
| □ 24 I/O: 110 x 90 x 70 mm (4.33 x 3.54 x 2.75 in.) | □ 32 I/O: 70 x 90 x 70 mm (2.75 x 3.54 x 2.75 in.) |
| □ 40 I/O: 163 x 90 x 70 mm (6.41 x 3.54 x 2.75 in.) | |
| Supply voltage | |
| 24V $\overline{\text{---}}$ or 100..240 V \sim 50/60 Hz | 24 V $\overline{\text{---}}$ |
| Connection of the embedded I/O | |
| On removable screw terminal blocks at intervals of 5.08 mm ; 24V/0,25A supply provided by the controller to the sensor inputs on TM221C●●●R models | 16 I/O: on removable spring or screw terminal blocks at intervals of 3.81 mm (0.15 in.) 32 I/O: on HE10 connectors with HE 10 cables/bare wires or Telefast ABE7 connection sub-bases (1) |
| Analog inputs | |
| 2 embedded inputs on each TM221M●●● and TM221C●●● controller | |
| 2 to 4 optional analog inputs with TMC2●●● cartridges | – |
| Embedded Ethernet communication | |
| Yes on TM221CE●● | Yes on TM221ME●● |
| Serial link | |
| 1 embedded | 1 to 2 embedded |
| 1 optional serial link with TMC2SL1 communication cartridge | – |
| Cartridges | |
| One slot for 1 or 2 cartridges depending on the model of controller: analog I/O cartridge, communication cartridge or application cartridges (hoisting, conveying and packaging) | – |
| Hardware characteristics | |
| M221 and M221 Book controllers each have an embedded: | |
| □ Run/Stop switch | |
| □ slot for SD memory card | |
| □ QR code for direct access to its technical documentation | |

(1) Telefast Modicon ABE7 pre-wired system: to be ordered separately, see page 2/19.



QRcode example :
QRcode for access to the technical data sheet for TM221M16R logic controller



SoMachine Basic software

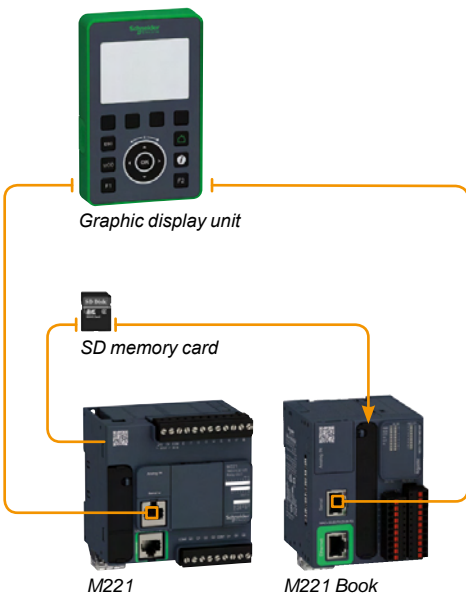

Presentation

Embedded communication

M221 and M221 Book logic controllers have 3 types of integrated communication port:

- Ethernet
- RS 232/RS 485 serial link
- programming port

These communication ports are described on page 2/14.

Embedded functions

Each Modicon M221 and Book logic controller has the following integrated functions:

- Analog (PID control)
- Counting: up to 4 high-speed counters (HSC), 100 kHz frequency

TM221C●●T, TM221CE●●T, TM221M16T●, TM221ME16T●, TM221M32TK and TM221ME32TK controllers integrate the position control function with:

- Pulse width modulation (PWM)
- Pulse generator (PLS)
- 2 P/D pulse train outputs (PTO) with trapezoidal profile and S curve, 100 kHz frequency (▲)

Processing power

- Execution speed: 0.2 μs/boolean instruction
- Program: 10 K boolean instructions
- Number of words: 8000
- Number of internal bits: 512

Programming

M221 and M221 Book logic controllers are programmed with the SoMachine Basic software. See page 5/6.

SoMachine Basic is an integral component of the SoMachine software.

SoMachine Basic is available on DVD and also as a free download from site www.schneider-electric.com.

Options for Modicon M221 and M221 Book controllers

Graphic display unit ▲

The TMH2GDB display unit is a compact display unit dedicated to M221 and M221 Book logic controllers offering diagnostic, maintenance and runtime functions.

- The display unit can be connected to the SL1 serial link of M221 and M221 Book controllers. This port also provides the power needed by the display unit.
- A single hole with diameter 22 mm (0.866 in.) allows it to be mounted on the front of the enclosure.
- The display application is resident in the controller, it is not necessary to load the program in the TMH2GDB.

Memory card

The TMA5D1 SD memory card, with 256 MB capacity, is available for:

- backup and transfer application
- firmware loading
- duplication of application between controllers

▲ Availability of functions with trapezoidal profile and S curve: 4th quarter 2014.

▲ Available: 4th quarter 2014.

Hardware control platforms

Modicon M221 and M221 Book logic controllers Options for Modicon M221 and M221 Book logic controllers

2

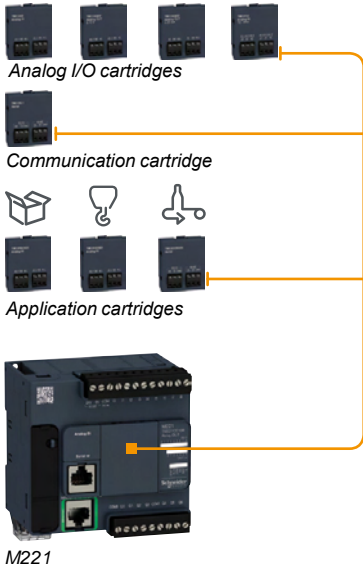

Option for Modicon TM221C●●● controllers

Cartridges for M221 controller

One or two cartridges can be inserted on the front of TM221C●●● controllers without increasing the dimensions.

3 types of cartridge are offered:

- Analog I/O cartridges
 - **TMC2AI2** for 2 analog inputs which can be configured as voltage or current
 - **TMC2AQ2V** for 2 voltage analog outputs
 - **TMC2AQ2C** for 2 current analog outputs
 - **TMC2TI2** for 2 temperature inputs
- Communication cartridge
 - **TMC2SL1** cartridge providing additional serial link port terminals for connection of a printer, barcode reader, etc.
- Application cartridges
 - **TMC2HOIS01** for hoisting applications has two dedicated analog inputs for controlling a load cell.
 - **TMC2PACK01** for packaging applications has two dedicated analog inputs for controlling the temperature on a packaging machine.
 - **TMC2CONV01** for conveyor system applications has a serial link.

Using an application cartridge provides direct access to application examples via the SoMachineBasic software.

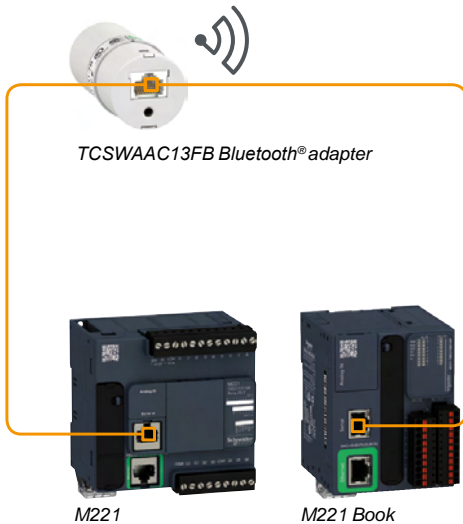

Communication option for Bluetooth® wireless connection

The Bluetooth® wireless connection enables complete freedom of movement within a radius of 10 m (32.808 ft.) around the controller.

For its M221 and M221 Book controllers Schneider Electric offers the

TCSWAAC13FB Bluetooth® adapter to perform the following functions:

- commissioning
- monitoring
- downloading

Hardware control platforms

Modicon M221 and M221 Book logic controllers

I/O extensions with Modicon TM3 expansion modules

I/O extensions with Modicon TM3 expansion modules

Modicon TM3 expansion modules (see page 3/20)

The capacity of M221 and M221 Book logic controllers can be enhanced with the Modicon TM3 expansion module offer:

- Digital I/O modules which can be used to create configurations with up to 264 digital I/O. These modules are available with the same connections as the controllers.
- Analog I/O modules which can be used to create configurations with up to 114 analog I/O and are designed to receive, amongst other things, position, temperature, and speed sensor signals. They are also capable of controlling variable speed drives or any other device equipped with a current or voltage input.
- Expert module for control of TeSys motor-starters, connected with RJ 45 cables to simplify wiring up the control section.
- Functional Safety modules that simplify wiring and can be configured in the SoMachine Basic software.

In addition, the TM3 expansion system is flexible due to the possibility of remotely locating some of the TM3 modules in the enclosure or another cabinet, up to 5 meters (16.404 ft.) away, using a bus expansion system.

The Modicon TM3 expansion system is common to the whole range of Modicon M221, M241 and M251 logic controllers, meaning that the model of controller can be revised without changing expansion module.

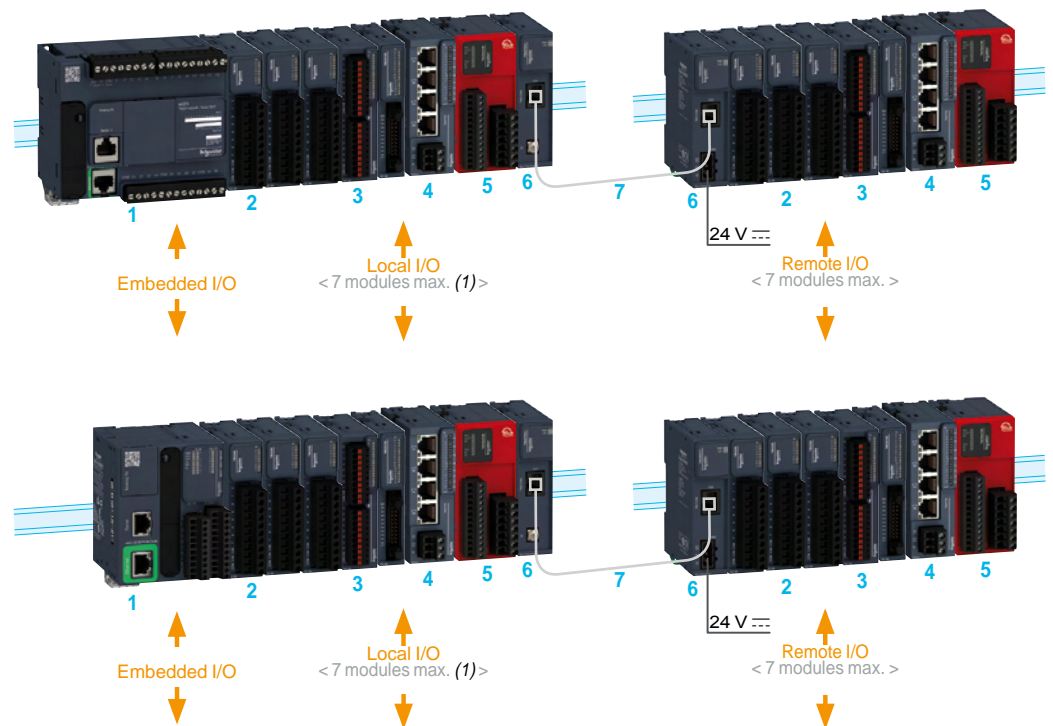

- 1 Modicon M221/M221 Book logic controller
- 2 Modicon TM3 digital I/O modules
- 3 Modicon TM3 analog I/O modules (2)
- 4 Modicon TM3 expert module: control of TeSys motor-starters
- 5 Modicon TM3 functional safety modules
- 6 Modicon TM3 bus expansion module (transmitter and receiver)
- 7 TM3 bus expansion cable

(1) Depending on type of TM3 module used (see page 3/24).

(2) Compatibility of expansion module offers: the majority of Modicon TM2 expansion modules can be used with M221 and M221 Book logic controllers. However, adding a Modicon TM2 expansion module in a configuration can increase expansion module execution times by a few milliseconds.

Control architecture for standalone machines

Typical applications: repetitive machines

- Packaging: recycling machines.
- Textile-clothing machines.
- Commercial equipment: automatic wash units, advertising hoardings, etc.
- Construction/service sector: access and entry control for automated systems.
- Other sectors: woodworking, agriculture, fish farming, incubators, swimming pools, etc.

■ M221 (TM221C●●●●) controllers

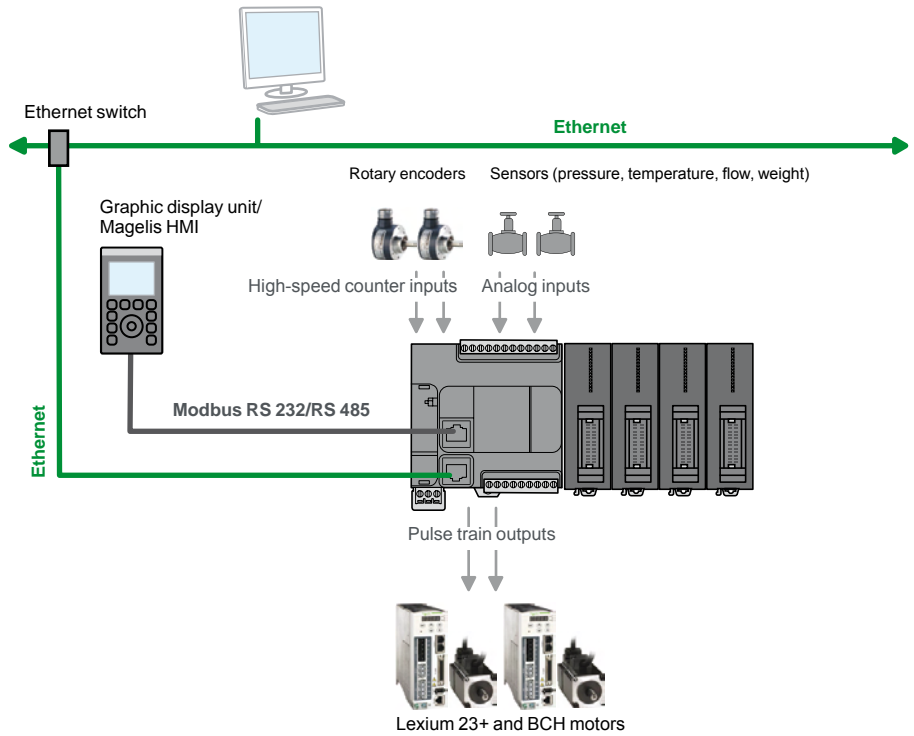

■ M221 Book (TM221M●●●) controllers

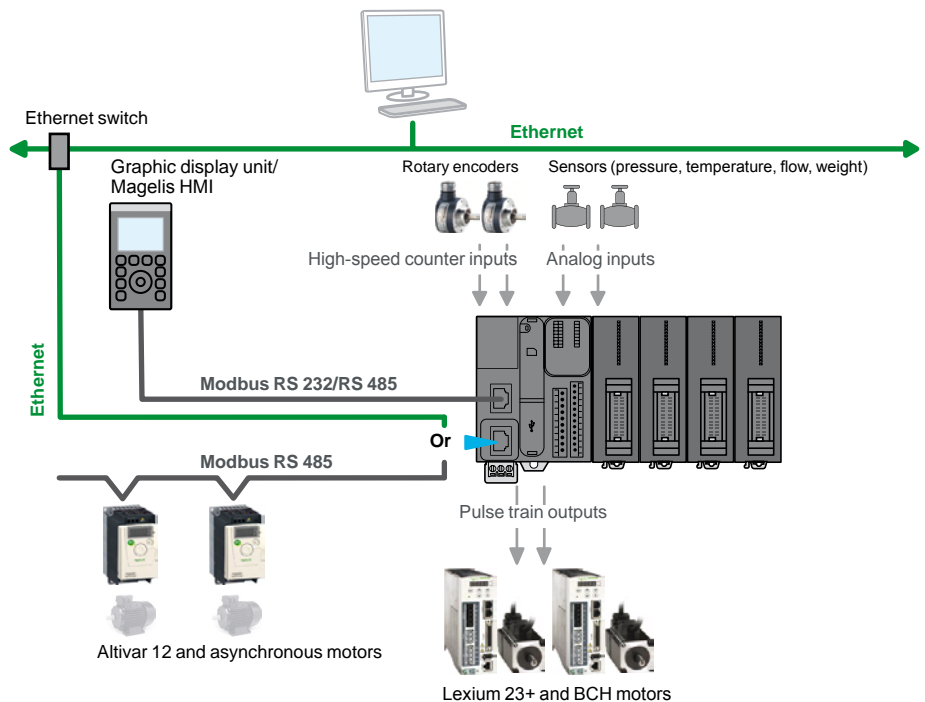

Embedded communication

Communication on Ethernet network

TM221CE●●● and TM221ME●●● controllers have an embedded RJ 45 Ethernet port (10/100 Mbps, MDI/MDIX) with Modbus TCP (Client/Server), Ethernet IP (adapter), UDP, TCP, SMS (▲) and email (▲) protocols.

- As well as the default address based on the MAC address, a controller IP address can be assigned via a DHCP server or via a BOOTP server.
- The Ethernet port also offers the uploading, updating and debugging functions of the application when the controller is supplied with power.
- The integrity of applications is maintained by cybersecurity functions.
- A firewall allows to lock each communication protocol.

Connection cables and accessories for Ethernet network (see page 4/46).

Serial links

- Each TM221C●●● controller has an embedded serial link that can be configured as RS 232 or RS 485. A 5 V/200 mA power supply is available on the RJ 45 connector, for using the **TMH2GDB** display unit, a Magelis **XBTN** or **XBTRT** HM, the Bluetooth® **TCSWAAC13FB** communication adapter.
- Each TM221M●●● (Book) controller has one or two embedded serial links.
- The SL1 serial link, found on each M221 Book controller, can be configured as RS 232 or RS 485. In addition, a 5 V/200 mA power supply is available on the RJ 45 connector which then supplies the **TMH2GDB** display unit, a Magelis **XBTN** or **XBTRT** HMI, the Bluetooth® **TCSWAAC13FB** communication adapter or other devices.
- The SL2 serial link, found on TM221M●●● controllers only, is configured as RS 485.

Serial links also provide the functionality for loading, updating and development when the controller is powered.

Embedded in both links the two main protocols used in the market

- Modbus ASCII/RTU Master or Slave
- Character string (ASCII)

Connection cables and accessories for serial link (see page 4/4).

Software programming with power off charging function

The programming port, equipped with a USB mini-B connector, is embedded in each M221 and M221 Book controller; it is dedicated to communication with a PC equipped with SoMachine Basic for programming, debugging, and maintenance. In addition, it offers the ability to upload an application program or update the firmware without the controller being powered by another source.

Characteristics of M221 and M221 Book logic controllers

Conformity

■ Certifications

- CE, cULus Listing Mark, C-Tick, EAC, LR, ABS, DNV and GL (1)

■ Standards

- IEC/EN 61131-2 (Edition 2 2007), UL 508 (UL 61010-2-201), ANSI/ISA 12.12.01-2007, CSA C22.2 No. 213, No. 142, E61131-2 and I ACS E10

Environment characteristics

- Ambient operating temperature: - 10...+ 55 °C (14...+ 131 °F).
- Storage temperature: - 25...+ 70°C (- 13...+ 158°F)
- Relative humidity: 10...95 % (non-condensing)
- Operating altitude: 0...2,000 m (0...6,561 ft)
- Storage altitude: 0...3,000 m (0...9,842 ft)
- Immunity to mechanical stress (vibrations):
 - For 1131: 5...8.4 Hz (amplitude 3.5 mm/0.138 in.); 8.4...150 Hz (acceleration 1 g)
 - For merchant marine: 5...13.2 Hz (amplitude 1.0 mm/0.039 in.); 13.2...100 Hz (acceleration 0.7 g)

Supply characteristics

Two power supply types are available depending on M221 controller model: 24 V --- or 100-240 V ~

- Voltage limit (ripple included): 19.2...28.8 V ---/85...264 V ~
- Immunity to micro-cuts (class PS-2): 10 ms
- Max. consumption: 17.2 W

(1) LR, ABS, DNV and GL marine certifications: pending.

▲ Available: 4th quarter 2014.

Hardware control platforms

Modicon M221 and M221 Book logic controllers

Modicon M221

2

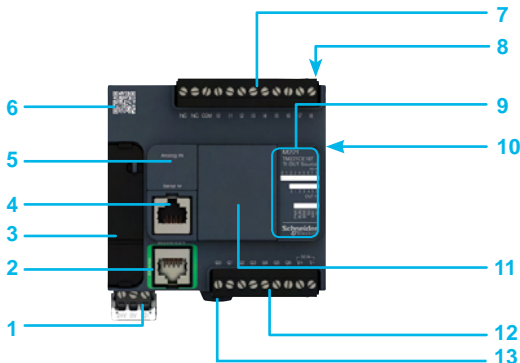

M221: 16 I/O

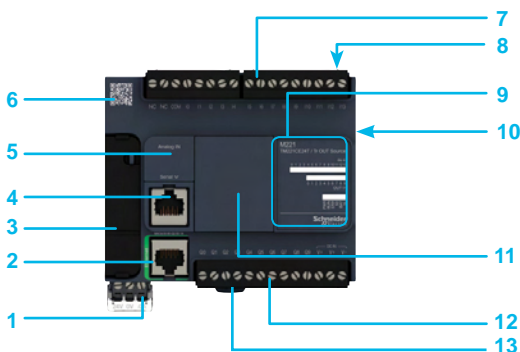

M221: 24 I/O

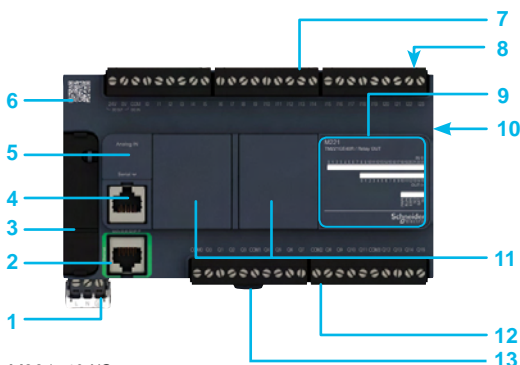

M221: 40 I/O



TMH2GDB

Description

M221 (TM221C●●●) logic controllers

- 1 Removable screw terminal block, 3 terminals for connecting the 24 V $\overline{\text{DC}}$ or the 100-240 V \sim power supply (depending on model)
- 2 On TM221CE●●● controllers: RJ 45 connector for Ethernet network, with exchange rate and activity LED.
- 3 Behind the removable cover:
 - USB mini-B connector for connecting a PC equipped with the SoMachine Basic software
 - Slot for the SD memory card
 - Run/Stop switch
- 4 Serial link port (RS 232 or RS 485): RJ 45 connector.
- 5 Behind a cover: dedicated removable connector for two analog inputs.
- 6 Controller technical documentation QR code.
- 7 Connection of 24 V $\overline{\text{DC}}$ logic inputs on removable screw terminal blocks (1).
- 8 On top of the controller: slot for backup battery.
- 9 LED display block showing:
 - the status of the controller and its components (battery, SD memory card)
 - the status of the serial link
 - the status of the I/O
- 10 On the side of the controller: TM3 bus connector for the link with a Modicon TM3 expansion module.
- 11 Slot(s) for I/O cartridge(s), communication cartridge or application cartridge(s): one on M221 controllers with 16 and 24 I/O, two on M221 controllers with 40 I/O.
- 12 Connection of relay/transistor logic outputs: on removable screw terminal blocks (1).
- 13 Clip for locking on \perp symmetrical rail.

(1) Removable screw terminal blocks equipped with screw terminals, supplied with M221 logic controller.

Graphic display unit TMH2GDB ▲

- 1 Control screen:
 - backlit STN graphic screen, two-tone (white/red), 240 x 160 pixels
 - graphic objects: bar charts, buttons, lights, graphic symbols
 - languages available: main international alphabets available in two sizes: 5 x 7 pixels and 11 x 15 pixels
 - 2 Ten command buttons, two of which can be customized with the option of identifying associated functions.
 - 3 Rotary navigation and control wheel.
- On the back of the display unit:
- 4 Mounting system consisting of: locking nut, seal and anti-rotation tee.
 - 5 RJ 45 connector for the cable linking the graphic display to the controller.

Characteristics of the graphic display unit

The graphic display unit conforms to CE, UL and CSA standards.

- Ambient operating temperature: - 10...+ 55°C (+ 14...+ 131°F).
- Degree of protection: IP 65.
- Power supply: 5 V $\overline{\text{DC}}$ (200 mA) directly by the controller.
- Power consumption: 1 W.
- Dimensions (w x h x d): 80 x 126 x 19.2 mm/3.15 x 4.96 x 0.75 in.
- Mounting: the display unit is mounted on a cabinet door in a hole \varnothing 22 mm (0.866 in.), fixed onto it with a locking nut, in the same way as a pushbutton.

▲ Available: 4th quarter 2014.

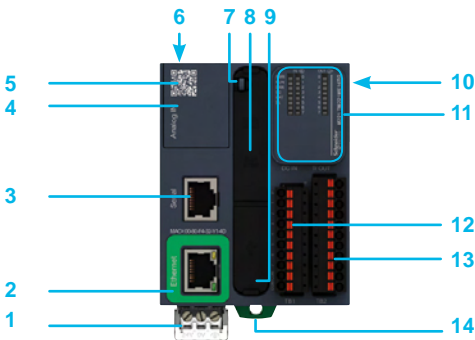

TM221ME16TG

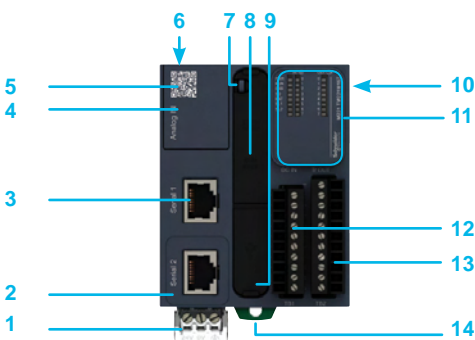

TM221M16T

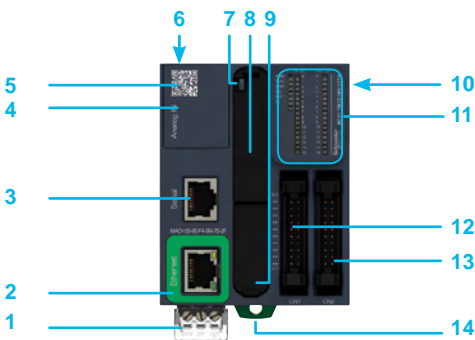

TM221ME32TK



TMH2GDB

Description

M221 Book logic controllers (TM221M●●●)

- 1 Removable screw terminal block, 3 terminals for connecting the 24 V $\bar{\text{---}}$ power supply.
- 2 On TM221ME16●● and TM221ME32●● controllers: RJ 45 connector for Ethernet network, with exchange rate and activity LED.
On TM221M16●● and TM221M32●● controllers: RJ 45 connector for SL2 serial link.
- 3 SL1 serial link port (RJ 45 connector).
- 4 Behind a cover: dedicated removable connector for two analog inputs.
- 5 Controller technical documentation QR code.
- 6 Backup battery slot.

Behind the removable cover: 7, 8 and 9

- 7 Slot for the SD memory card.
- 8 Run/Stop switch.
- 9 USB mini-B connector, for connecting a PC equipped with the SoMachine Basic software.
- 10 TM3 bus connector for linking to a Modicon TM3 expansion module.
- 11 LED display block showing:
 - the status of the controller and its components (battery, SD memory card)
 - the status of the serial link
 - the status of the I/O
- 12 Connection of 24 V $\bar{\text{---}}$ logic inputs:
 - on 16-channel controllers: removable spring or screw terminal blocks (1)
 - on 32-channel controllers: HE10 connector
- 13 Connection of relay/transistor logic outputs:
 - on 16-channel controllers: removable spring or screw terminal blocks (1)
 - on 32-channel controllers: HE10 connector
- 14 Clip for locking on $\bar{\text{---}}$ symmetrical rail.

(1) Removable terminal blocks equipped with screw or spring-type terminals depending on controller type. Terminal blocks supplied with M221 Book controller.

Graphic display unit TMH2GDB ▲

Description and characteristics: see page 2/16

▲ Available: 4th quarter 2014.

Hardware control platforms

Modicon M221 and M221 Book logic controllers

Modicon M221 logic controllers

2



TM221C16R
TM221C16T



TM221CE16R
TM221CE16T



TM221C24R
TM221C24T



TM221CE24R
TM221CE24T



TM221C40R
TM221C40T



TM221CE40R
TM221CE40T



TMC2AI2



TMC2AQ2V



TMC2AQ2C



TMC2TI2



TMC2SL1



TMC2PACK01



TMC2HOIS01



TMC2CONV01

References

Modicon M221 logic controllers (1)

| Number of logic I/O | Logic inputs | Logic outputs | Analog inputs | Integrated communication ports (2) | | Reference | Weight kg/lb |
|---------------------|--------------|---------------|---------------|------------------------------------|---------------------|-----------|--------------|
| | | | | Ethernet (RJ 45) | Serial link (RJ 45) | | |

■ 100-240 V ~ power supply

| | | | | | | | |
|-------------------|---|-----------------|---------------------|---|---|-----------|-----------------|
| 16 inputs/outputs | 9 sink/source 24 V $\overline{\text{---}}$ inputs, inc. 4 high-speed inputs | 7 relay outputs | 2 x 0...10 V inputs | – | 1 | TM221C16R | 0.346/ 0.763 |
| | | | | 1 | 1 | | |

| | | | | | | | |
|-------------------|--|------------------|---------------------|---|---|-----------|-----------------|
| 24 inputs/outputs | 14 sink/source 24 V $\overline{\text{---}}$ inputs, inc. 4 high-speed inputs | 10 relay outputs | 2 x 0...10 V inputs | – | 1 | TM221C24R | 0.395/ 0.871 |
| | | | | 1 | 1 | | |

| | | | | | | | |
|-------------------|--|------------------|---------------------|---|---|-----------|-----------------|
| 40 inputs/outputs | 24 sink/source 24 V $\overline{\text{---}}$ inputs, inc. 4 high-speed inputs | 16 relay outputs | 2 x 0...10 V inputs | – | 1 | TM221C40R | 0.456/ 1.005 |
| | | | | 1 | 1 | | |

■ 24 V $\overline{\text{---}}$ power supply

| | | | | | | | |
|-------------------|---|--|---------------------|---|---|-----------|-----------------|
| 16 inputs/outputs | 9 sink/source 24 V $\overline{\text{---}}$ inputs, inc. 4 high-speed inputs | 7 source transistor outputs, inc. 2 high-speed outputs | 2 x 0...10 V inputs | – | 1 | TM221C16T | 0.346/ 0.763 |
| | | | | 1 | 1 | | |

| | | | | | | | |
|-------------------|---|---|---------------------|---|---|-----------|-----------------|
| 24 inputs/outputs | 14 sink/source 4 V $\overline{\text{---}}$ inputs, inc. 4 high-speed inputs | 10 source transistor outputs, inc. 2 high-speed outputs | 2 x 0...10 V inputs | – | 1 | TM221C24T | 0.395/ 0.871 |
| | | | | 1 | 1 | | |

| | | | | | | | |
|-------------------|--|---|---------------------|---|---|-----------|-----------------|
| 40 inputs/outputs | 24 sink/source 24 V $\overline{\text{---}}$ inputs, inc. 4 high-speed inputs | 16 source transistor outputs, inc. 2 high-speed outputs | 2 x 0...10 V inputs | – | 1 | TM221C40T | 0.456/ 1.005 |
| | | | | 1 | 1 | | |

Options for Modicon M221 logic controllers (3)

| Description | Function | Reference | Weight kg/lb |
|-------------|----------|-----------|--------------|
|-------------|----------|-----------|--------------|

| | | | |
|----------------|---|---------|-----------------|
| I/O cartridges | 2 analog inputs (12-bit resolution) which can be configured as: - 0...10 V voltage - 0...20 mA/4...20 mA current Connection via screw terminal block | TMC2AI2 | 0.025/ 0.055 |
|----------------|---|---------|-----------------|

| | | | |
|--|--|----------|-----------------|
| | 2 analog outputs (12-bit resolution) 0...10 V voltage Connection via screw terminal block | TMC2AQ2V | 0.025/ 0.055 |
|--|--|----------|-----------------|

| | | | |
|--|---|----------|-----------------|
| | 2 analog outputs (12-bit resolution) 4...20 mA current Connection via screw terminal block | TMC2AQ2C | 0.025/ 0.055 |
|--|---|----------|-----------------|

| | | | |
|--|--|---------|-----------------|
| | 2 temperature inputs (12-bit resolution) type K, J, R, S, B, E, T, N, C, PT100, PT1000, NI100, NI1000 Connection via screw terminal block | TMC2TI2 | 0.025/ 0.055 |
|--|--|---------|-----------------|

| | | | |
|-------------------------|--|---------|-----------------|
| Communication cartridge | 1 additional serial link on screw terminal block | TMC2SL1 | 0.025/ 0.055 |
|-------------------------|--|---------|-----------------|

| | | | | |
|-------------------------------------|----------------------|-----------------|------------|-----------------|
| Cartridges for specific application | Hoisting application | 2 analog inputs | TMC2HOIS01 | 0.025/ 0.055 |
|-------------------------------------|----------------------|-----------------|------------|-----------------|

| | | | | |
|--|-----------------------|-----------------|------------|-----------------|
| | Packaging application | 2 analog inputs | TMC2PACK01 | 0.025/ 0.055 |
|--|-----------------------|-----------------|------------|-----------------|

| | | | | |
|--|-----------------------------|---------------|------------|-----------------|
| | Conveyor system application | 1 serial link | TMC2CONV01 | 0.025/ 0.055 |
|--|-----------------------------|---------------|------------|-----------------|

- (1) M221 controllers are supplied with:
- removable screw terminal blocks for connecting the I/O
 - a removable screw terminal block for connecting the power supply
 - a button cell backup battery (BR2032)
 - a cable for connecting the analog inputs

(2) Each M221 logic controller has an embedded USB mini-B programming port.

(3) One cartridge for controllers with 16 and 24 I/O. Two cartridges maximum for controllers with 40 I/O, only one of which can be a communication cartridge.



TM221M16RG



TM221M16T



TM221ME16RG



TM221ME16T



TM221M16TG



TM221M32TK



TM221ME32TK

| References | | | | | | | | | |
|---|---|---|---------------------|----------------------------------|-------------------------|-------------------------|---|-------------|--------------|
| Modicon M221 Book logic controllers (1) | | | | | | | | | |
| 24 V $\bar{\text{---}}$ power supply | | | | | | | | | |
| No. of logic I/O | Logic inputs | Logic outputs | Analog inputs | Embedded communication ports (2) | | | Term. block for I/O conn. Interval (mm/in.) | Reference | Weight kg/lb |
| | | | | Ethernet (RJ 45) | Serial link SL1 (RJ 45) | Serial link SL2 (RJ 45) | | | |
| 16 inputs/ outputs | 8 sink/source 24 V $\bar{\text{---}}$ inputs, inc. 4 high-speed inputs | 8 relay outputs | 2 x 0...10 V inputs | – | 1 | 1 | screw (3.81/0.15) | TM221M16R | 0.264/0.582 |
| | | | | – | 1 | 1 | spring (3.81/0.15) | TM221M16RG | 0.264/0.582 |
| | | | | 1 | 1 | – | screw (3.81/0.15) | TM221ME16R | 0.264/0.582 |
| | | | | 1 | 1 | – | spring (3.81/0.15) | TM221ME16RG | 0.264/0.582 |
| | | | | – | 1 | 1 | screw (3.81/0.15) | TM221M16T | 0.264/0.582 |
| | | | | – | 1 | 1 | spring (3.81/0.15) | TM221M16TG | 0.264/0.582 |
| 32 inputs/ outputs | 16 sink/source 24 V $\bar{\text{---}}$ inputs, inc. 4 high-speed inputs | 16 source transistor outputs, inc. 2 high-speed outputs | 2 x 0...10 V inputs | – | 1 | 1 | screw (3.81/0.15) | TM221M32TK | 0.270/0.595 |
| | | | | 1 | 1 | – | HE 10 connector | TM221ME32TK | 0.270/0.595 |
| | | | | – | 1 | 1 | spring (3.81/0.15) | TM221M32TK | 0.270/0.595 |
| | | | | 1 | 1 | – | HE 10 connector | TM221ME32TK | 0.270/0.595 |
| | | | | – | 1 | 1 | screw (3.81/0.15) | TM221M32TK | 0.270/0.595 |
| | | | | – | 1 | 1 | spring (3.81/0.15) | TM221ME32TK | 0.270/0.595 |

- (1) M221 Book controllers are supplied with:
- removable terminal blocks (screw or spring-type depending on controller model) for connecting the I/O
 - a removable screw terminal block for connecting the power supply
 - a button cell backup battery (BR2032)
 - a cable for connecting the analog inputs

(2) Each M221 Book logic controller has an embedded USB mini-B programming port.

Hardware control platforms

Modicon M221 and M221 Book logic controllers

Options, separate parts, software, cordsets

2



TMH2GDB



TMASD1

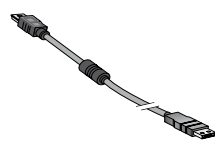

TCSXCNAMUM3P

References

Common options for Modicon M221 and M221 Book logic controllers

| Description | Function | Reference | Weight kg/ lb |
|----------------------|---|-----------|---------------------|
| Graphic display unit | Display and modification of data | TMH2GDB ▲ | – – |
| SD memory card | Application backup and program transfer capacity: 256 MB | TMASD1 | 0.004/ 0.009 |

Separate parts for Modicon M221 and M221 Book logic controllers

| Description | Details | Reference | Weight kg/ lb |
|------------------------------------|---|-----------|---------------------|
| Mounting kit Sold in lots of 10 | For plate or panel mounting of M221 and M221 Book controllers | TMAM2 | 0.065/ 0.143 |

Replacement parts

| Description | Details | Unit reference | Weight kg lb |
|--|---|----------------|--------------------|
| Set of terminal blocks for connecting the power supply on M221 and M221 Book logic controllers | 8 removable screw terminal blocks | TMAT2PSET | 0.127/ 0.280 |
| Set of terminal blocks for connecting the I/O on M221 controllers | Removable screw terminal connectors: 8 different connectors for equipping a TM221C●●●● logic controller (8 x I/O) | TMAT2CSET | 0.127/ 0.280 |
| Set of terminal blocks for connecting the I/O on M221 Book controllers | 4 x 10-way and 4 x 11-way removable terminal blocks with screw terminals | TMAT2MSET | 0.127/ 0.280 |
| | 4 x 10-way and 4 x 11-way removable terminal blocks with spring terminals | TMAT2MSETG | 0.127/ 0.280 |

Backup battery The battery supplied with each controller is not available as a separate element Schneider reference. If necessary spare parts, use only a Panasonic BR2032 battery type.

Programming software

| Description | For use with | Reference |
|-----------------|--|--------------|
| SoMachine Basic | Modicon M221 and M221 Book logic controllers | See page 5/6 |

Expansion modules

| Description | For use with | Reference |
|-------------------------------|--|---------------|
| Modicon TM3 expansion modules | Modicon M221 and M221 Book logic controllers | See page 3/20 |

Cordsets

| Description | For use | Length m/ft | Reference | Weight kg/ lb |
|---|--|----------------|---------------------|---------------------|
| Programming cables | From the PC USB port to the USB mini-B port on M221 and M221 Book controllers | 3/ 0.98 | TCSXCNAMUM3P (1) | 0.065/ 0.143 |
| | | 1.8/ 5.90 | BMXXCAUSBH018 | 0.065/ 0.143 |
| Cable for connecting the analog inputs embedded in M221 and M221 Book controllers | Equipped with 1 dedicated removable connector at one end and bare wires at the other end | 1/ 3.28 | TMACBL1 | 0.024/ 0.053 |

(1) Unshielded cable without grounding. To be used only for temporary connections. For permanent connections, use the reference BMXXCAUSBH018 programming cable.

▲ Available: 4th quarter 2014.

Telefast pre-wired system with Modicon ABE7

For 32-channel Modicon M221 Book logic controller and Modicon TM3 digital I/O expansion modules

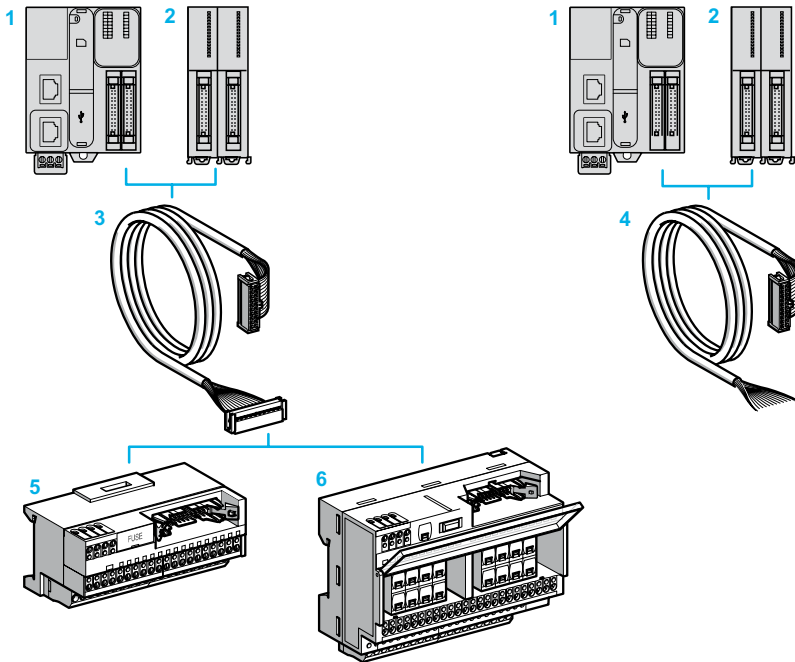

Possible combinations:

- (1 or 2) + 3 + (5 or 6)
- (1 or 2) + 4

- 1 32-channel Modicon M221 Book logic controllers (TM221M32TK, TM221ME32TK), equipped with HE 10 connectors.
- 2 Digital I/O modules (TM3D●●●K) with 16 or 32 I/O, equipped with HE 10 connectors.
- 3 ABFT20E●●● cordsets with one HE 10 connector at each end.
- 4 TWDFCW●●● cordsets with an HE 10 connector at one end and flying leads at the other end for direct connections to sensors, preactuators and terminal blocks.
- 5 16-channel sub-base for input expansion modules.
- 6 16-channel sub-base for output expansion modules.

Combinations of Modicon ABE7 sub-bases with M221 Book controllers and TM3 expansion modules

| | | Modicon M221 Book logic controllers | | Modicon TM3 I/O expansion modules | | |
|----------------------|-------------------|--|--------------|-----------------------------------|------------------------------|------------------------|
| | | TM221M32TK TM221ME32TK | TM221ME32TK | Digital inputs | Source outputs | Sink outputs |
| 16-channel sub-bases | Miniature passive | ABE7E16EPN20 (1) ABE7E16SPN20 (2) ABE7E16SPN22 (2) | ABE7E16EPN20 | TM3DI16K TM3DI32K | TM3DQ16TK TM3DQ32TK | TM3DQ16UK TM3DQ32UK |
| | 2 A relay | ABE7E16SRM20 (2) | – | – | ABE7E16SPN20 ABE7E16SPN22 | Use TWDFCW●●● cordsets |
| | | | | | ABE7E16SRM20 | Use TWDFCW●●● cordsets |

(1) Compatible with inputs only.
(2) Compatible with outputs only.

compatible

References

| Sub-bases | | Compatibility | LED on each chnnl. | Fuse | Reference | Weight kg/lb |
|-----------------------------|--|------------------------------|--------------------|------|--------------|--------------|
| Number and type of channels | | | | | | |
| 16 inputs | Sink: 24 V $\overline{\text{---}}$ | TM221M32TK/ME32TK, TM3DI●●K | No | No | ABE7E16EPN20 | 0.430/0.948 |
| 16 outputs | Source: 24 V $\overline{\text{---}}$ | TM221M32TK/ME32TK, TM3DQ●●TK | No | No | ABE7E16SPN20 | 0.450/0.992 |
| | | | Yes | Yes | ABE7E16SPN22 | 0.450/0.992 |
| | Relay: 24 V $\overline{\text{---}}$ / 250 V \sim , 2 A | TM221M32TK/ME32TK, TM3DQ●●TK | No | No | ABE7E16SRM20 | 0.430/0.948 |

| Cordsets | | | | | | | |
|--------------------------|---|------------------|--------------|----------------------|----------|------------|-------------|
| Description | Compatibility | Cable connection | | Gauge/CSA | Length | Reference | Weight |
| | | M221 and TM3 | Telefast end | mm ² | m/ft | | kg/lb |
| Cordsets for digital I/O | TM221M32TK, TM221ME32TK, TM3DI16K, TM3DI32K, TM3DQ16TK, TM3DQ32TK | 20-way HE 10 | 20-way HE 10 | AWG 28 | 0.5/1.64 | ABFT20E050 | 0.060/0.132 |
| | | | | 0.08 mm ² | 1/3.28 | ABFT20E100 | 0.080/0.176 |
| | | | | | 2/6.56 | ABFT20E200 | 0.140/0.309 |
| | | | | | 3/9.84 | TWDFCW30K | 0.405/0.893 |
| | | | | | 5/16.40 | TWDFCW50K | 0.670/1.477 |



ABE7E16EPN20



ABE7E16SRM20

Hardware control platforms

Modicon M241 logic controllers

Applications

Control of simple motion Control of control loops



Supply voltage

100-240 V ~ 24 V ☐

Inputs/Outputs

24 logic inputs/outputs

- Logic inputs/outputs
- No. and type of inputs
- No. and type of outputs
- Connection of logic inputs/outputs

| | | |
|---|---|--|
| 14 sink/source 24 V ☐ inputs, inc. 8 high-speed inputs | 14 sink/source 24 V ☐ inputs, inc. 8 high-speed inputs | 14 sink/source 24 V ☐ inputs, inc. 8 high-speed inputs |
| 10 outputs: with 4 source transistor high-speed outputs and 6 relay outputs | 10 source transistor outputs, inc. 4 high-speed outputs | 10 sink transistor outputs, inc. 4 high-speed outputs |
| With removable screw terminal block | | |

I/O extension

- 7 Modicon TM3 expansion modules
- 14 Modicon TM3 expansion modules with the use of bus expansion modules (transmitter and receiver)
- Possible use of Modicon TM2 expansion modules with restrictions

Embedded communication

Ethernet link
1 Ethernet port on TM241CE24● and TM241CEC24● controllers: Modbus TCP (client & server), Modbus TCP slave, dynamic DHCP Client Configuration, Programming, download monitoring. Updated firmware, data exchange - NGVL and IEC VAR ACCESS, WEB server, IP Ethernet adapter SNMP network management. MIB2, FTP file transfer

CANopen

1 CANopen port on TM241CEC24● controllers (1 screw terminal block): 63 slaves, 252 TPDO/252 RPDO

Serial link

2 serial link ports:
 1 port SL1 (RJ 45), RS232/485 with +5 V supply
 1 port SL2 (screw terminal) RS485

Functions

Process control
Counting
Position control

PID
8 high-speed counter (HSC) inputs, 200 kHz frequency

4 position control outputs:
 P/D, CW and CCW pulse train (PTO) with trapezoidal profile and S curve (▲), 100 kHz frequency
 pulse width modulation (PWM)
 frequency generator (FG)

Options

- Cartridges
- 3 I/O expansion cartridges:
 - with 2 voltage/current analog inputs
 - with 2 inputs for temperature probes
 - with 2 voltage/current analog outputs
- 2 application cartridges:
 - for control of hoisting applications
 - for control of packaging applications

Number of cartridge slots

1

Communication modules

- 1 Ethernet port Modicon TM4 module with switch function and 4 integrated ports for TM241C24●
- 1 Modicon TM4 module for slave Profibus DP link

Mounting

Mounting on symmetrical rail or panel

Software programming

With SoMachine software (see page 5/2)

Controller type

| | | | |
|--|-------------|-------------|-------------|
| with serial links | TM241C24R | TM241C24T | TM241C24U |
| with embedded Ethernet port and serial links | TM241CE24R | TM241CE24T | TM241CE24U |
| with embedded Ethernet and CANopen ports, and serial links | TM241CEC24R | TM241CEC24T | TM241CEC24U |

Pages

2/30

▲ Available: 4th quarter 2014.

Control of simple motion Control of control loops



Supply voltage

100-240 V ~ 24 V ☐

Inputs/Outputs

40 logic inputs/outputs

| | | |
|--|---|--|
| 24 sink/source 24 V ☐ inputs, inc. 8 high-speed inputs | 24 sink/source 24 V ☐ inputs, inc. 8 high-speed inputs | 24 sink/source 24 V ☐ inputs, inc. 8 high-speed inputs |
| 16 outputs: with 4 source transistor high-speed outputs and 12 relay outputs | 16 source transistor outputs, inc. 4 high-speed outputs | 16 sink transistor outputs, inc. 4 high-speed outputs |
| With removable screw terminal block | | |

- 7 Modicon TM3 expansion modules
- 14 Modicon TM3 expansion modules with the use of bus expansion modules (transmitter and receiver)
- Possible use of Modicon TM2 expansion modules with restrictions

Ethernet link
1 Ethernet port on TM241CE40● and TM241CEC40● controllers: Modbus TCP (client & server), Modbus TCP slave, dynamic DHCP Client Configuration, Programming, download monitoring. Updated firmware, data exchange - NGVL and IEC VAR ACCESS, WEB server, IP Ethernet adapter SNMP network management. MIB2, FTP file transfer

Serial link

2 serial link ports:
 1 port SL1 (RJ 45), RS232/485 with +5 V supply
 1 port SL2 (screw terminal) RS485

Functions

Process control
Counting
Position control

PID
8 high-speed counter (HSC) inputs, 200 kHz frequency

4 position control outputs:
 P/D, CW and CCW pulse train (PTO) with trapezoidal profile and S curve (▲), 100 kHz frequency
 pulse width modulation (PWM)
 frequency generator (FG)

- Cartridges
- 3 I/O expansion cartridges:
 - with 2 voltage/current analog inputs
 - with 2 inputs for temperature probes
 - with 2 voltage/current analog outputs
- 2 application cartridges:
 - for control of hoisting applications
 - for control of packaging applications

Number of cartridge slots

2

- 1 Ethernet port Modicon TM4 module with switch function and 4 integrated ports for TM241C24●
- 1 Modicon TM4 module for slave Profibus DP link

Mounting

Mounting on symmetrical rail or panel

Software programming

With SoMachine software (see page 5/2)

| | | | |
|--|------------|------------|------------|
| with serial links | TM241C40R | TM241C40T | TM241C40U |
| with embedded Ethernet port and serial links | TM241CE40R | TM241CE40T | TM241CE40U |
| with embedded Ethernet and CANopen ports, and serial links | - | - | - |

Pages

2/30

▲ Available: 4th quarter 2014.

2

Compatibility of offers

Modicon M241 logic controllers

- > Modicon TM3 expansion modules
- > Modicon TM2 expansion modules
- > Modicon TM4 communication modules
- > SoMachine software



M241 logic controller with 24 I/O



M241 logic controller with 40 I/O



QRcode example :
QRcode for access to the technical data sheet for
TM241CEC24R logic controller



SoMachine software

Presentation

Applications

Modicon M241 logic controllers are designed for high-performance compact machines incorporating speed and position control functions. They have an embedded Ethernet port offering FTP and web server services, meaning they can easily be integrated in control system architectures for remote monitoring and maintenance of machines by means of applications for smartphones, tablets and PCs.

- The wealth of embedded functions minimizes the cost of the machine:
 - Functions embedded in the controller: Modbus serial link, USB port dedicated to programming, CANopen fieldbus for distributed architectures, advanced position control functions (high-speed counters and pulse train outputs for servo motor control).
 - Functions embedded in the Modicon TM3 expansion: functional safety modules, motor-starter control module and remote expansion system.
 - Functions embedded in the Modicon TM4 communication modules.
- The processing power and the memory size of M241 controllers are ideal for targeting performance applications.
- The application is created quickly thanks to the intuitive nature and power of the SoMachine programming software. It also makes it easy to retrieve existing applications in the Modicon M221, M238 and M258 ranges automatically, maximizing use of the investment already made.

Key features

M241 logic controllers come in 2 formats (w x h x d):

- controllers with 24 I/O: 150 x 90 x 95 mm (5.90 x 3.54 x 3.74 in.)
- controllers with 40 I/O: 190 x 90 x 95 mm (7.48 x 3.54 x 3.74 in.)

- Inputs and outputs embedded in M241 controllers are connected on removable screw terminal blocks, supplied with the controllers.
- A Run/Stop switch is available on each M241 controller.
- A slot for an SD memory card (Secure Digital card) is available on each M241 controller.

A slot integrated in each M241 controller can take up to 2 cartridges of the following types:

- analog input or output expansion cartridges
- application cartridges: hoisting or packaging (1)

Each M241 logic controller has a QR code for direct access to its technical documentation.

Embedded communication

M241 logic controllers have up to 5 integrated communication ports:

- Ethernet with embedded Web server function
- CANopen (master)
- 2 serial links
- Programming port

Embedded functions

- PID control
- 8 high-speed counter (HSC) inputs, 200 kHz frequency
- 4 position control outputs for:
 - P/D, CW and CCW pulse train (PTO) with trapezoidal profile and S curve, 100 kHz frequency
 - pulse width modulation (PWM)
 - frequency generator (FG)

Processing power

- Execution speed: 22 ns/boolean instruction
- Program: 128 K boolean instructions
- DualCore CPU
- RAM: 64 MB
- Flash memory: 128 MB

Programming

M241 logic controllers are programmed with SoMachine software (see page 5/2).

(1) Use only one Application cartridge (inserted into the left slot of the Modicon M241 controllers).

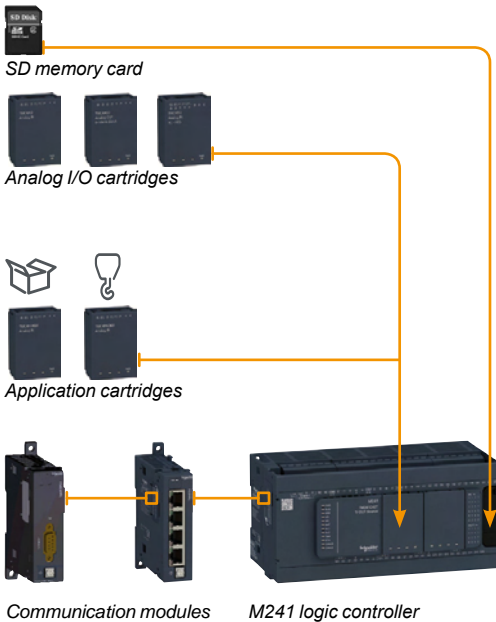

Options for Modicon M241 controllers

Memory card

The **TMASD1** SD memory card, 256 MB capacity, is available for:

- backup and application transfer
- data logging
- firmware updating

Cartridges for Modicon M241 controller

Up to 2 cartridges (depending on controller model) can be inserted on the M241 controller front panel without increasing its dimensions.

I/O cartridges

3 input or output cartridges are available:

- TMC4AI2** cartridge for 2 analog inputs which can be configured as voltage or current
- TMC4AQ2** cartridge for 2 analog outputs which can be configured as voltage or current
- TMC4TI2** cartridge for 2 inputs which can be configured for temperature probes

Application cartridges

2 cartridges are available:

- The **TMC4HOIS01** Hoisting application cartridge has two dedicated analog inputs for control of a load cell.
- The **TMC4PACK01** Packaging application cartridge has two dedicated analog inputs for temperature control on packaging machines. .

Use of an application cartridge provides direct access to Application Function Blocks via the SoMachine software.

Communication modules (1)

2 communication module models are available:

- The **TM4ES4** Ethernet switch module ; it offers on controllers without embedded Ethernet, an Ethernet connection with 4 ports.
- The **TM4PDPS1** Profibus DP slave module.

Modicon TM4 communication modules are assembled by simple interlocking on the left-hand side of the controllers and a bus expansion connector is used to distribute data and the power supply.

Up to 3 communication modules can be added on the left of M241 logic controllers.

See page 4/42.

Ethernet switch module

The **TM4ES4** module is a 4-port Ethernet interface (10/100 Mbps, MDI/MDIX) with the following protocols: Modbus TCP (Client/Server), Ethernet IP (adapter), UDP, TCP, SNMP and SoMachine.

- The **TM4ES4** module is ready for use as soon as it is connected to the communication bus of M241 controllers.
- This module is used to add the Ethernet function to TM241C24● and TM241C40● controllers without embedded Ethernet port while offering the additional functionality of an Ethernet switch.
- When connected to logic controllers with embedded Ethernet port type TM241CE24●●● and TM241CE40●●● it is a 4 port stand-alone switch: the communication between the TM4ES4 module and the Modicon M241 controller is not done automatically by the bus connector.

Profibus DP slave module

The **TM4PDPS1** communication module can be used to configure a slave connection on Profibus DP.

(1) For association rules between ModiconTM4 communication modules and Modicon M241 logic controllers, see page 4/42.

Hardware control platforms

Modicon M241 logic controllers

Communication option for Bluetooth® wireless connection

2

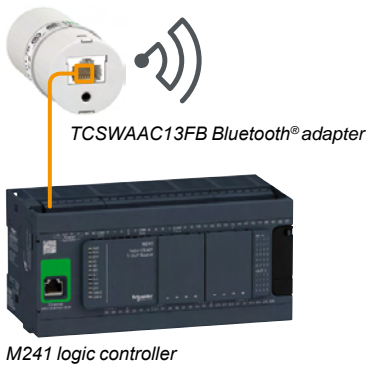

Communication option for Bluetooth® wireless connection

The Bluetooth® wireless connection enables complete freedom of movement within a radius of 10 m (32.81 ft.) around the controller.

For its M241 controllers Schneider Electric offers the **TCSWAAC13FB** Bluetooth® adapter to perform the following functions:

- commissioning
- monitoring

I/O extensions with Modicon TM3 modules

Modicon TM3 expansion modules (see page 3/20)

The capacity of M241 logic controllers can be enhanced with the Modicon TM3 expansion module offer:

- Digital I/O modules which can be used to create configurations with up to 264 digital I/O. These modules are available with the same connections as the controllers.
- Analog I/O modules which can be used to create configurations with up to 114 analog I/O and are designed to receive, amongst other things, position, temperature or speed sensor signals. They are also capable of controlling variable speed drives or any device equipped with a current or voltage input.
- Expert modules for control of TeSys motor starters which simplify wiring up the control section due to connection with RJ45 cables.
- Functional Safety modules which simplify wiring and can be configured in the SoMachine software.

In addition, the TM3 expansion system is flexible due to the possibility of remotely locating some of the TM3 modules in the enclosure or another cabinet, up to 5 meters (16.404 ft.) away, using a bus expansion system.

The Modicon TM3 expansion system is common to the whole range of Modicon M221, M241 and M251 logic controllers, meaning that the model of controller can be revised without changing expansion module.

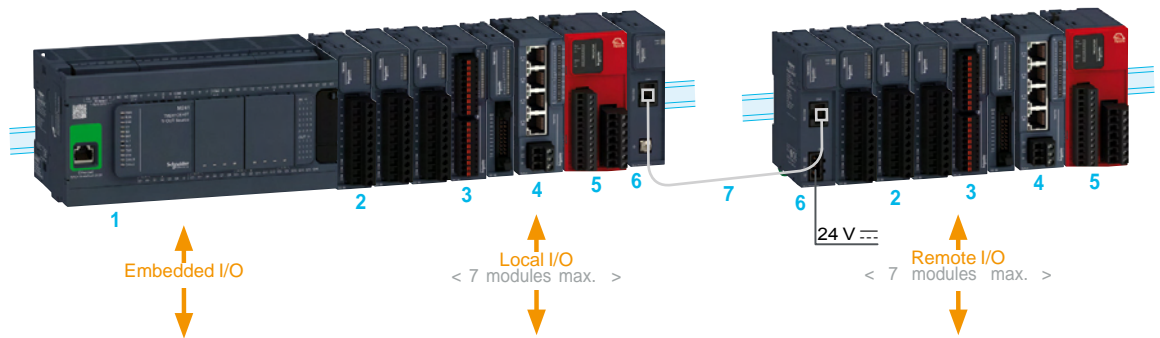

- 1 M241 logic controller.
- 2 Modicon TM3 digital I/O modules.
- 3 Modicon TM3 analog I/O modules (1).
- 4 Modicon TM3 expert module: control of TeSys motor starters.
- 5 Modicon TM3 functional safety modules.
- 6 Modicon TM3 bus expansion module (transmitter and receiver).
- 7 TM3 bus expansion cable.

(1) Compatibility of expansion module offers: the majority of Modicon TM2 expansion modules can be used with M241 logic controllers. However, adding a Modicon TM2 expansion module in a configuration can increase expansion module execution times by a few milliseconds.

Embedded communication

M241 logic controllers have up to 5 embedded communication ports:

- Two serial links: SL1 (RJ 45) and SL2 (screw terminal block) and a programming port (USB mini-B) on each controller.
- An Ethernet port (RJ 45) or an Ethernet port (RJ 45) and a CANopen port depending on the controller model.

Communication on Ethernet network

TM241CE●●● controllers have an embedded Ethernet RJ 45 port (10/100 Mbps, MDI/MDIX) with Modbus TCP (Client/Server), Ethernet IP (adapter), UDP, TCP, SNMP and SoMachine protocols.

- Each M241 controller has an embedded web server and FTP server. As well as the default address based on the MAC address, it is possible to assign a controller IP address via a DHCP server or via a BOOTP server.
- The Ethernet port also offers the same uploading, updating and debugging functions as the programming port (USB mini-B) when the controller is supplied with power.
- A firewall allows to filter IP addresses accessing the controller and to lock each communication protocol.

Connection cables and accessories for Ethernet network: see page 4/46.

Communication on CANopen

TM241CEC●●● controllers have an embedded CANopen master port.

The link can be configured between 20 Kbps and 1 Mbps and supports up to 63 slaves.

- Architectures based on CANopen can be used to distribute I/O modules as close to the sensors and actuators as possible, thus reducing wiring costs and times, and to communicate with different devices such as variable speed drives, servo drives, etc.
- The CANopen configurator is integrated in the SoMachine software and can also be used to import standard description files in EDS format.

CANopen connection cables and accessories: see page 4/13.

Serial links

Each M241 controller has 2 embedded serial links.

- The SL1 serial link can be configured as RS 232 or RS 485. In addition, a 5 V/200 mA power supply is available on the RJ 45 connector which allows the use of a Magelis **XBTN** or **XBTRT** HMI, the **TCSWAAC13FB** Bluetooth® communication adapter or other devices.
- The serial link is configured as RS 485.

Embedded in both links are the two main protocols used in the market :

- Modbus ASCII/RTU Master or Slave
- ASCII character string

Connection cables and accessories for serial link: see page 4/6.

Programming port with power off charging function

The programming port, equipped with a mini-B USB connector, is embedded on each M241 controller; it is dedicated to communication with a PC equipped with SoMachine for:

- programming
- debugging
- maintenance

In addition, it offers the ability to upload an application program or update the firmware without the controller being supplied with power from another source.

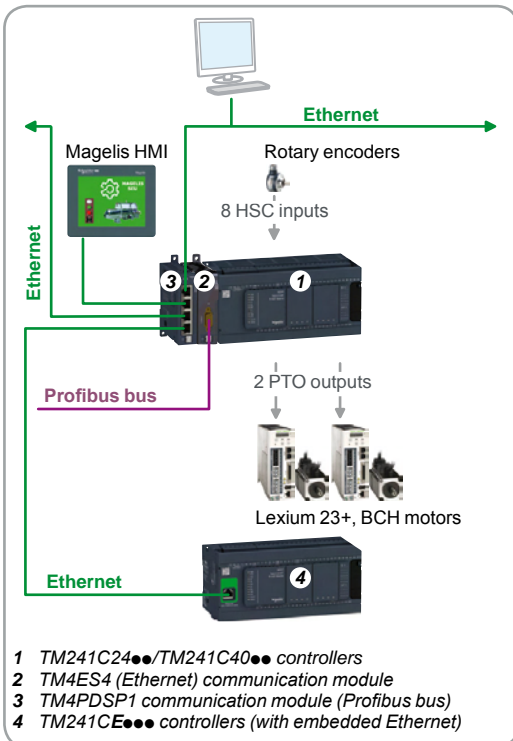
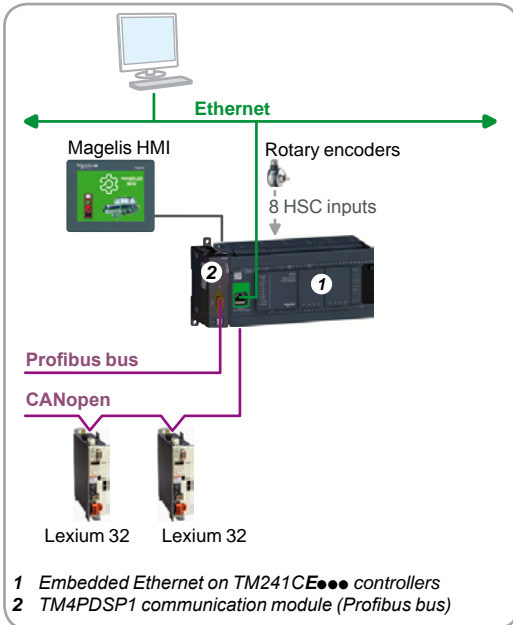

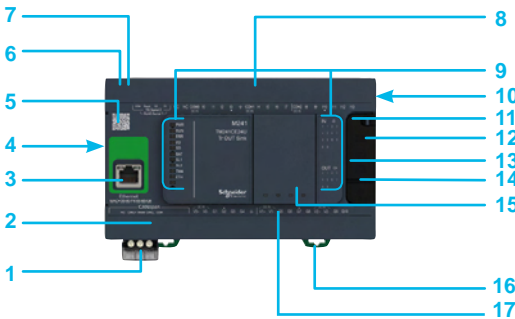

M241 controller 24 I/O

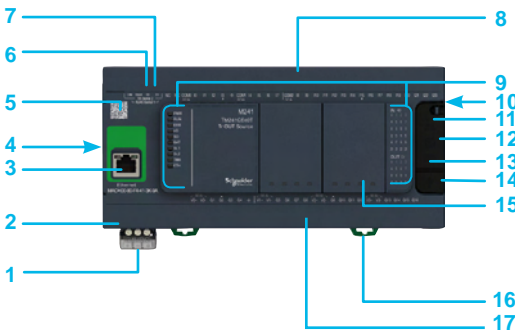

M241 controller 40 I/O

Description

M241 controllers

- 1 Removable screw terminal block, 3 terminals for connecting the 24 V $\overline{\text{DC}}$ or the 100-240 V \sim 50/60 Hz power supply (depending on model).
 - 2 On TM241CEC●●● controllers: connector for linking to the CANopen bus (screw terminal block).
 - 3 On TM241CE●●● controllers: RJ 45 connector for Ethernet network, with exchange rate and activity LED.
 - 4 TM4 bus connector: communication bus for connecting to the TM4●●● communication modules.
 - 5 Controller technical documentation QR code.
 - 6 SL1 serial link port (RS 232 or RS 485): RJ 45 connector.
 - 7 SL2 serial link port (RS485): screw terminal blocks.
 - 8 Connection of 24 V $\overline{\text{DC}}$ logic inputs: removable screw terminal blocks (1).
 - 9 LED display block showing:
 - the status of the controller and its components (battery, SD memory card)
 - the status of the embedded communication ports (CANopen bus, serial links, Ethernet)
 - the status of the I/O
 - 10 TM3 bus connector for linking to a Modicon TM3 expansion module.
- Behind a removable cover: 11,12, 13, 14, 15**
- 11 Run/Stop switch.
 - 12 SD memory card slot.
 - 13 Backup battery slot.
 - 14 Mini-B USB connector for connecting a programming port.
 - 15 Slot(s) for I/O cartridge(s) or application cartridge(s): one slot on TM241C●24, two slots on TM241C●40.
 - 16 Locking clip on \perp symmetrical rail.
 - 17 Connection of relay/transistor logic outputs: removable screw terminal blocks (1).

(1) Removable terminal blocks equipped with screw terminals. Terminal blocks supplied with controller.

Characteristics of M241 logic controllers

Conformity

- Certification
 - CE, cULus Listing Mark, C-Tick, EAC, LR, ABS, DNV and GL (1)
- Standards
 - IEC/EN 61131-2 (Edition 2 2007), UL508 (UL61010-2-201), ANSI/ISA 12.12.01-2007, CSA C22.2 No. 213, No. 142, E61131-2 and IACS E10

Environment characteristics

- Ambient operating temperature: - 10...+ 55°C (+14...+ 131°F).
- Storage temperature: - 40...+ 70°C (- 40...+ 158°F).
- Relative humidity: 5...95% (non-condensing).
- Operating altitude: 0...2000 m (0...6561 ft).
- Storage altitude: 0...3000 m (0...9842 ft).
- Immunity to mechanical stress:
 - For 1131: 5...8.4 Hz (amplitude 3.5 mm/0.14 in.); 8.4...150 Hz acceleration 1 g).
 - For merchant marine: 5...13.2 Hz (amplitude 1.0 mm/0.04 in.); 13.2...100 Hz (acceleration 0.7 g).

Supply characteristics

Two power supply types are available depending on M241 controller model: 24 V $\overline{\text{DC}}$ or 100-240 V \sim 50/60Hz

- Voltage limit (ripple included): 19.2...28.8 V $\overline{\text{DC}}$ /85...264 V \sim
- Immunity to micro-cuts (class PS-2): 10 ms
- Max. consumption: 45 W.

(1) Marine certifications LR, ABS, DNV and GL: pending.



TM241C24R



TM241C40R



TM241CEC24U



TM241CE24R



TM241CE40T



TM241CE40U



TMC4AI2



TMC4AQ2



TMC4TI2



TMC4HOIS01



TMC4PACK01



TMSD1

References

Modicon M241 logic controllers (1)

| No. of logic I/O | Logic inputs | Logic outputs | Embedded communication ports (2) | | | Reference | Weight kg/lb |
|---|--|--|----------------------------------|---------------------------------------|---|-------------|--------------|
| | | | Ethernet (RJ 45) | CANopen master (screw terminal block) | Serial links (RJ 45 and screw terminal block) | | |
| ■ 100-240 V ~ power supply | | | | | | | |
| 24 inputs/ outputs | 14 sink/source 24 V $\overline{\text{---}}$ inputs, inc. 8 high-speed inputs | 10 outputs: with 4 source transistor high-speed outputs and 6 relay outputs | – | – | 1 + 1 | TM241C24R | 0.530/1.168 |
| | | | 1 | – | 1 + 1 | TM241CE24R | 0.530/1.168 |
| | | | 1 | 1 | 1 + 1 | TM241CEC24R | 0.530/1.168 |
| 40 inputs/ outputs | 24 x 24 V $\overline{\text{---}}$ inputs, inc. 8 high-speed inputs | 16 outputs: with 4 source transistor high-speed outputs and 12 relay outputs | – | – | 1 + 1 | TM241C40R | 0.620/1.367 |
| | | | 1 | – | 1 + 1 | TM241CE40R | 0.620/1.367 |
| ■ 24 V $\overline{\text{---}}$ power supply | | | | | | | |
| 24 inputs/ outputs | 14 sink/source 24 V $\overline{\text{---}}$ inputs, inc. 8 high-speed inputs | 10 source transistor outputs, inc. 4 high-speed outputs | – | – | 1 + 1 | TM241C24T | 0.530/1.168 |
| | | | 1 | – | 1 + 1 | TM241CE24T | 0.530/1.168 |
| | | | 1 | 1 | 1 + 1 | TM241CEC24T | 0.530/1.168 |
| 40 inputs/ outputs | 14 sink/source 24 V $\overline{\text{---}}$ inputs, inc. 8 high-speed inputs | 10 sink transistor outputs, inc. 4 high-speed outputs | – | – | 1 + 1 | TM241C24U | 0.530/1.168 |
| | | | 1 | – | 1 + 1 | TM241CE24U | 0.530/1.168 |
| | | | 1 | 1 | 1 + 1 | TM241CEC24U | 0.530/1.168 |
| 40 inputs/ outputs | 24 sink/source 24 V $\overline{\text{---}}$ inputs, inc. 8 high-speed inputs | 16 source transistor outputs, inc. 4 high-speed outputs | – | – | 1 + 1 | TM241C40T | 0.620/1.367 |
| | | | 1 | – | 1 + 1 | TM241CE40T | 0.620/1.367 |
| | | | 1 | – | 1 + 1 | TM241C40U | 0.620/1.367 |
| TM241CE40U | 0.620/1.367 | | | | | | |

Options for Modicon M241 logic controllers

| Designation | Description | Reference | Weight kg/lb |
|---|--|------------|--------------|
| I/O cartridges | 2 analog inputs (12-bit resolution) configurable as: - 0...10 V voltage - 0...20 mA/4...20 mA current Connected on screw terminal block | TMC4AI2 | 0.025/0.055 |
| | 2 analog outputs (16-bit resolution) configurable as: - 0...10 V voltage - 0...20 mA/4...20 mA current Connected on screw terminal block | TMC4AQ2 | 0.025/0.055 |
| | 2 inputs (14-bit resolution) configurable for temperature probes: - Thermocouple/PT100/PT1000/Ni100/Ni1000 Connected on screw terminal block | TMC4TI2 | 0.025/0.055 |
| Cartridges for specific application (3) | Hoisting application: 2 analog inputs for a load cell Connected on screw terminal block | TMC4HOIS01 | 0.025/0.055 |
| | Packaging application: 2 analog inputs Connected on screw terminal block | TMC4PACK01 | 0.025/0.055 |
| SD memory card | Application backup and program transfer Capacity: 256 MB | TMSD1 | 0.004/0.009 |

(1) Modular M241 controllers are supplied with:

- Removable terminal blocks (screw terminals) for connecting the I/O with thread of 3.81 mm (0.15 in.).
- A removable terminal block for connecting the power supply with thread of 5.08 mm (0.2 in.).
- A button cell backup battery (BR2032).

(2) Each M241 logic controller has an embedded USB mini-B programming port.

(3) Use only one Application cartridge (inserted into the left slot of the Modicon M241 controllers).

Hardware control platforms

Modicon M241 logic controllers

Separate parts, software, cordsets

| References | | | | | |
|---|---|--|---------------------|----------------------------|---------------------|
| Spare parts | | | | | |
| Designation | Description | Unit reference | Weight kg/ lb | | |
| Set of connectors for connecting the I/O | Removable connectors with screw terminals: 8 different connectors for equipping a M241 logic controller (1 x SL2, 6 x I/O, 1 x CANopen) | TMAT4CSET | 0.127/ 0.280 | | |
| Set of terminal blocks for connecting the power supply | 8 removable terminal blocks with screw terminals | TMAT2PSET | 0.127/ 0.280 | | |
| Backup battery | The battery supplied with each controller is not available as a separate element Schneider reference. If necessary spare parts, use only a Panasonic BR2032 battery type. | | | | |
| Programming software | | | | | |
| Designation | Used for | Reference | | | |
| SoMachine software | M241 logic controllers | See page 5/2 | | | |
| Expansion modules | | | | | |
| Description | Used for | Reference | | | |
| Modicon TM3 expansion modules | M241 logic controllers | See page 3/20 | | | |
| Communication modules | | | | | |
| Description | Used for | Reference | | | |
| Modicon TM4 communication modules | Ethernet port module , Profibus DP slave module | See page 4/43 | | | |
| Cordsets | | | | | |
| Designation | For use From | To | Length m/ft | Reference | Weight kg/ lb |
| Programming cables | PC USB port | USB mini-B port on M221, M241, M251 and M258 controllers | 3/ 0.98 | TCSXCNAMUM3P (1) | 0.065/ 0.143 |
| | | | 1.8/ 5.90 | BMXXCAUSBH018 | 0.065/ 0.143 |

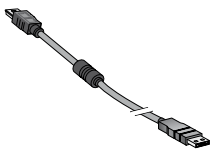

TCSXCNAMUM3P

(1) Unshielded cable without grounding. To be used only for temporary connections. For permanent connections, use the reference BMXXCAUSBH018 programming cable.

Applications

Control of modular machines on distributed architectures



Supply voltage

24 V $\overline{\text{---}}$

I/O expansion

- 7 Modicon TM3 expansion modules
- 14 Modicon TM3 expansion modules with the use of bus expansion modules (transmitter and receiver)
- Possible use of Modicon TM2 expansion modules with restrictions.

| | |
|------------------------|---------------|
| Embedded communication | Ethernet link |
| | CANopen |
| | Serial link |

- Ethernet 1: 2 ports connected by a switch, "Machine" or "Factory" network (2 RJ 45 connectors)
 - Ethernet 2: 1 "fieldbus" Ethernet port (1 RJ 45 connector)
- Modbus TCP (client & server), Modbus TCP slave, dynamic DHCP Client Configuration, Programming, download monitoring.
Updated firmware, data exchange - NGVL and IEC VAR ACCESS, WEB server, IP Ethernet adapter SNMP network management.MIB2, FTP file transfer
-
- 1 serial link port (RJ 45), RS232/485 with +5 V supply

Options

Communication modules

- 1 Ethernet port Modicon TM4 module with switch function and 4 integrated ports
- 1 Modicon TM4 module for slave Profibus DP link

Mounting

Mounting on \perp symmetrical rail or panel

Software programming

With SoMachine software (see page 5/2)

Controller type

TM251MESE

Pages

2/41

Control of modular machines on distributed architectures



Supply voltage

24 V $\overline{\text{---}}$

- 7 Modicon TM3 expansion modules
- 14 Modicon TM3 expansion modules with the use of bus expansion modules (transmitter and receiver)
- Possible use of Modicon TM2 expansion modules with restrictions.

- Ethernet: 2 ports connected by a switch, "Machine" or "Factory" network (2 RJ 45 connectors)
- Modbus TCP (client & server), Modbus TCP slave, dynamic DHCP Client Configuration, Programming, download monitoring.
Updated firmware, data exchange - NGVL and IEC VAR ACCESS, WEB server, IP Ethernet adapter SNMP network management.MIB2, FTP file transfer
- 1 master CANopen port (1 x 9-way SUB-D connector)
- 1 serial link port (RJ 45), RS232/485 with +5 V supply

Options

Communication modules

- 1 Ethernet port Modicon TM4 module with switch function and 4 integrated ports
- 1 Modicon TM4 module for slave Profibus DP link

Mounting

Mounting on \perp symmetrical rail or panel

Software programming

With SoMachine software (see page 5/2)

TM251MESD

2/41

Compatibility of offers

Modicon M251 logic controllers

- > Modicon TM3 expansion modules
- > Modicon TM2 expansion modules
- > Modicon TM4 communication modules
- > SoMachine software



TM251MESE



TM251MESC



QRcode example :
QRcode for access to the technical data sheet for
TM251MESE logic controller



SoMachine software

Presentation

Applications

Modicon M251 controllers offer an innovative, high-performance solution in the field of modular machines and distributed architectures. Thanks to their compact dimensions, they can optimize the size of wall-mounted and floor standing control system enclosures.

Since Modicon M251 controllers have no embedded I/O, field devices such as variable speed drives and remote I/O are connected on either the CanOpen bus or the Ethernet network.

The Ethernet ports embedded in each M251 controller offer FTP and web server services, making it easy to integrate control system architectures and remote control of machines using applications for smartphones, tablets and PCs.

- The wealth of embedded functions minimizes the cost of the machine:
 - Functions embedded in the controller: Modbus serial link, USB port dedicated to programming, CANopen fieldbus for distributed architectures, advanced position control functions (high-speed counters and pulse train outputs for servo motor control).
 - Functions embedded in the Modicon TM3 expansion: functional safety modules, motor-starter control module and remote expansion system.
 - Functions embedded in the Modicon TM4 communication modules.
- The processing power and the memory size of M251 controllers are ideal for targeting performance applications.
- The application is created quickly thanks to the intuitive nature and power of the SoMachine programming software. It also makes it easy to retrieve existing applications in the Modicon M221, M238 and M258 ranges automatically, maximizing use of the investment already made.

Key features

- Both Modicon M251 logic controllers come in an identical format (w x h x d): 54 x 90 x 95 mm (2.13 x 3.54 x 3.74 in).
- Modicon M251 controllers have no embedded I/O but can be combined with Modicon TM3 expansion modules.
- Each M251 controller has a Run/Stop switch.
- Each M251 controller has a slot for an SD (Secure Digital) memory card.
- Each M251 controller has a QR code for direct access to its technical documentation.

Embedded connection

M251 logic controllers have up to 5 integrated communication ports.

- The **TM251MESE** controller has the following embedded features:
 - an "Ethernet 1" network (1) with 2 RJ 45 ports connected by an internal switch, this network being mainly for communication between machines or to your factory network.
 - an "Ethernet 2" network (1) with an RJ 45 port, optimized for connecting field devices (variable speed drives, distributed I/O, etc.) by means of the Ethernet I/O scanner service. This port can also be connected to a factory network.
- The **TM251MESC** controller has the following embedded features:
 - an "Ethernet" network (1) with 2 RJ 45 ports connected by an internal switch, this network being mainly for communication between machines or to your factory network.
 - a master CANopen port for connecting field devices (variable speed drives, distributed I/O, etc.).
- Moreover, both these M251 logic controllers incorporate:
 - a serial link port.
 - a programming port.

(1) Ethernet with embedded Web server function

Processing power

- Execution speed: 22 ns/boolean instructions.
- Program: 128 K boolean instructions.
- DualCore processor.
- RAM: 64 MB.
- Flash memory: 128 MB.

Programming

Modicon M251 logic controllers are programmed with the SoMachine software (see page 5/2).

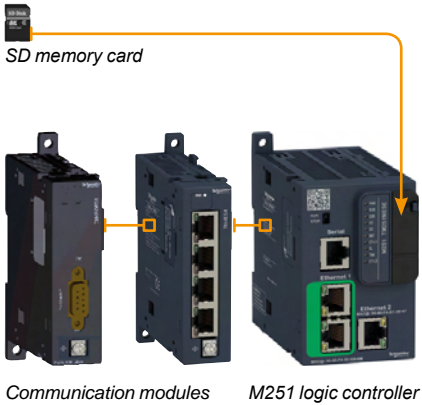

Options for Modicon M251 controllers

Memory card

The **TMASD1** SD memory card, with 512 MB capacity, is available for:

- application backup.
- program transfer.
- data logging.
- firmware updating.

Communication modules (1)

2 communication module models are available:

- The **TM4ES4** Ethernet switch module
- The **TM4PDPS1** Profibus DP slave module

Modicon TM4 communication modules are assembled by simple interlocking on the left-hand side of the controllers and a bus expansion connector is used to distribute data and the power supply.

Up to 3 communication modules can be added on the left of M251 logic controllers.

See page 4/42.

■ Ethernet switch module

- The **TM4ES4** module is a 4-port Ethernet interface (10/100 Mbps, MDI/MDIX).
- Clipped onto the left-hand side of a Modicon M251 controller, it consists of an autonomous switch with 4 ports supplied by the Modicon M251 controller.

■ PROFIBUS DP slave module

- The **TM4PDPS1** communication module can be used to configure a Master connection on the PROFIBUS DP bus.

(1) For association rules between Modicon TM4 communication modules and Modicon M251 logic controllers (see page 4/42).

2



Communication option for link Bluetooth® wireless link

The Bluetooth® wireless link enables complete freedom of movement within a radius of 10 m (32.808 ft.) around the controller.

For its M251 controllers Schneider Electric offers the **TCSWAAC13FB** Bluetooth® adapter to perform the following functions:

- commissioning
- monitoring

Hardware control platforms

Modicon M251 logic controllers

I/O extensions with Modicon TM3 expansion modules

I/O extensions with Modicon TM3 modules

Modicon TM3 expansion modules (see page 3/20)

Modicon M251 logic controllers have no embedded I/O, yet can still take Modicon TM3 expansion modules for connecting sensors and actuators locally:

- digital I/O modules for creating configurations with up to 224 digital I/O.
- analog I/O modules for creating configurations with up to 114 analog I/O, to receive the signals from, for example, position, temperature, and speed sensors and also capable of controlling variable speed drives or any other device with a current or voltage input.
- expert modules for controlling 4 TeSys motor-starters, connected with RJ 45 cordsets to simplify wiring the control section.
- Functional Safety modules that simplify the wiring and can be configured in the SoMachine software.

In addition, the Modicon TM3 expansion system is flexible due to the possibility of remotely locating some of the Modicon TM3 modules in the floor standing enclosure or another wall-mounted enclosure, up to 5 meters (16.404 ft.) away, thanks to the use of a bus expansion system.

The Modicon TM3 expansion system is common to the whole range of Modicon M221, M241 and M251 logic controllers, meaning that applications can be upgraded without changing extension.

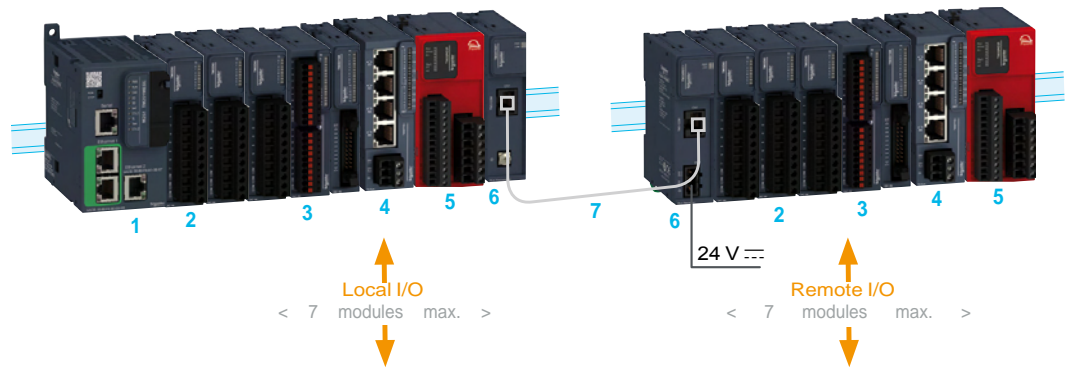

- 1 M251 logic controller.
- 2 Modicon TM3 digital I/O modules.
- 3 Modicon TM3 analog I/O modules (1).
- 4 Modicon TM3 expert module: for controlling TeSys motor-starters.
- 5 Modicon TM3 functional safety modules.
- 6 Modicon TM3 bus expansion modules (transmitter and receiver).
- 7 Modicon TM3 bus expansion cordset.

(1) Compatibility of expansion module offers: most Modicon TM2 expansion modules can be used with M251 logic controllers. Nonetheless, inserting a Modicon TM2 expansion module in a configuration can increase the expansion module execution times by as much as a few milliseconds.

Hardware control platforms

Modicon M251 logic controllers

Embedded connection

2

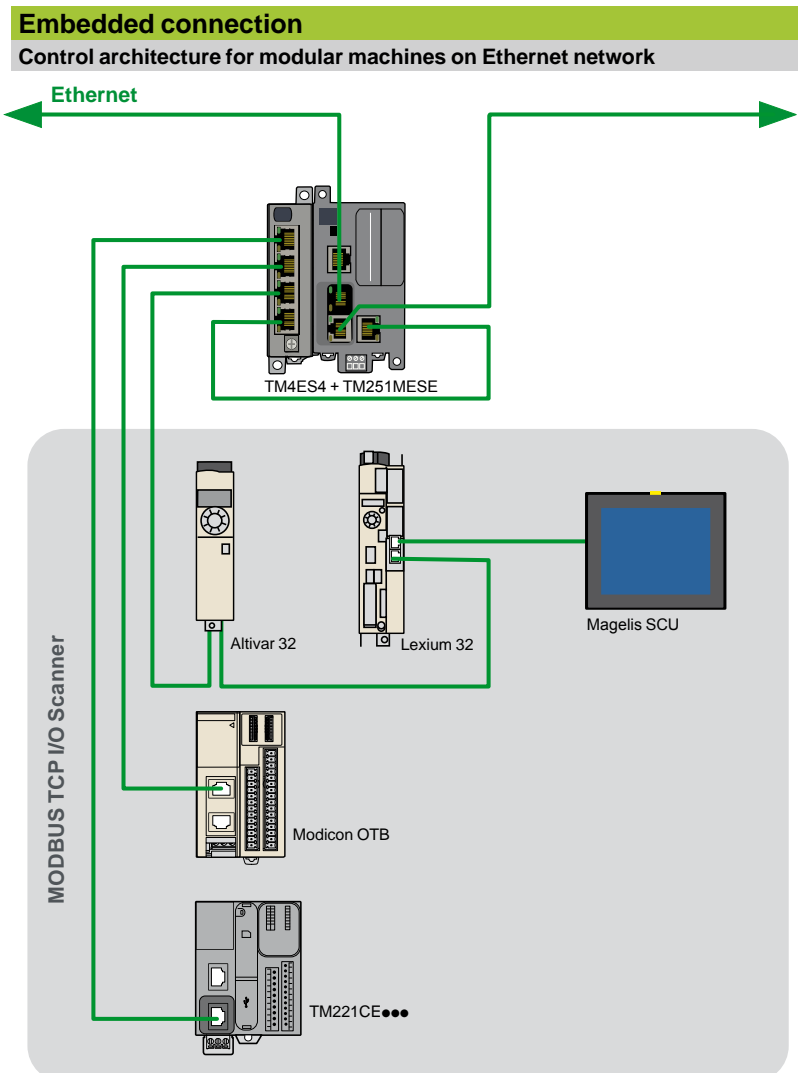

M251 controllers have 2 embedded Ethernet ports connected by an RJ 45 switch (10/100 Mbps, MDI/MDIX) with the Modbus TCP (Client/Server), Ethernet IP (adapter), UDP, TCP, SNMP and SoMachine on Ethernet protocols. These ports are mainly for communication between machines or to your factory network. These ports are marked "Ethernet" or "Ethernet 1".

- M251 controllers each have an embedded web server and FTP server. As well as the default address based on the MAC address, a controller IP address can be assigned via a DHCP server or via a BOOTP server.
- Ethernet ports also offer the same upload/download, update and debug functions as the programming port (USB mini-B) when the controller is supplied with power.
- A firewall allows to filter IP addresses accessing the controller and to lock each communication protocol.
- **TM251MESE** controllers have, in addition to the two embedded "Ethernet 1" ports, an embedded "Ethernet 2" Ethernet port optimized for connecting RJ 45 type field devices (variable speed drives, distributed I/O, etc.), with Ethernet Modbus TCP I/O scanner, Ethernet Modbus TCP (Client/Server), Ethernet IP (adapter), UDP, TCP, SNMP and SoMachine protocols.

Cordsets and connection accessories for Ethernet network (see page 4/46).

Embedded connection (continued)

Control architecture for modular machines on CANopen bus

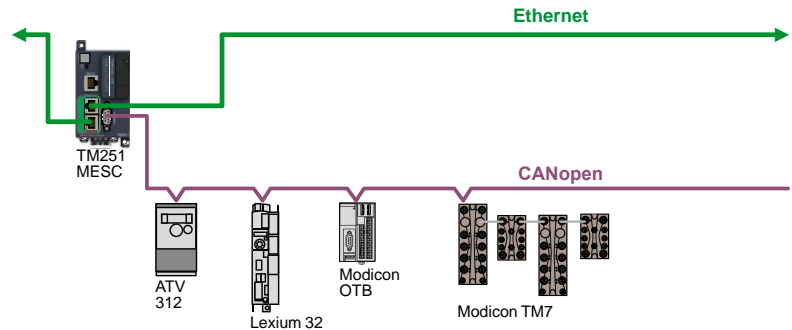

TM251MESC controllers have an embedded master CANopen port.

- The link can be configured between 20 Kbps and 1 Mbps and supports up to 63 slaves with 252 TPDO and 252 RPDO.
- CANopen-based architectures can be used to distribute I/O modules as close to the sensors and actuators as possible, thus reducing wiring costs and times, and to communicate with different devices such as variable speed drives, servo drives, etc.
- The CANopen configurator is integrated in the SoMachine software and can also be used to import standard description files in EDS format.

CANopen cordsets and connection accessories: see page 4/20.

Serial link

Each M251 controller has an embedded serial link that can be configured as RS 232 or RS 485.

In addition, a 5 V/200 mA power supply is available on the RJ 45 connector which allows the use of a Magelis **XBTN** or **XBTRT** HMI, the **TCSWAAC13FB** Bluetooth® communication adapter or other devices.

Embedded in both links are the two main protocols used in the market:

- Modbus ASCII/RTU Master or Slave.
- Character string (ASCII).

Connection cables and accessories for serial link: see page 4/6.

Programming port with power off charging function

The programming port, equipped with a mini-B USB connector, is embedded on each M251 controller; it is dedicated to communication with a PC equipped with SoMachine for:

- programming
- debugging
- maintenance

In addition, it offers the ability to upload an application program or update the firmware without the controller being supplied with power from another source.

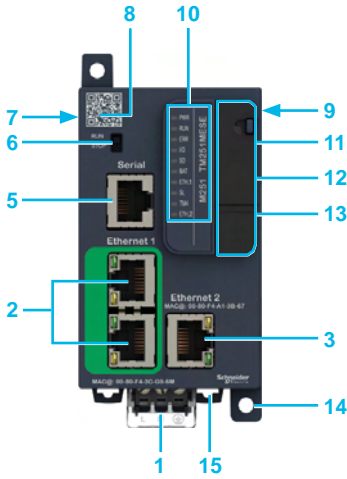

TM251MESE controller

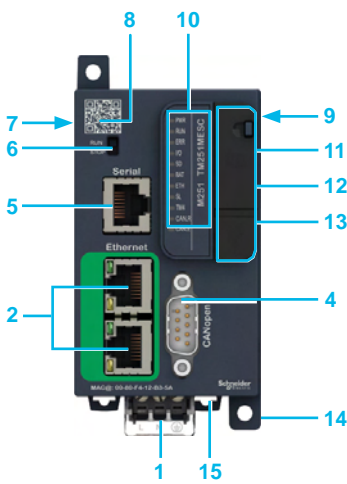

TM251MESG controller

Description

M251 controllers

- 1 Removable screw terminal block, 3 terminals for connecting the 24 V $\bar{\bar{}}$ power supply.
- 2 Two RJ 45 connectors connected by an internal switch for “Machine” or “Factory” Ethernet network, with exchange rate and activity LED.
- 3 On **TM251MESE** controller: RJ 45 connector for Ethernet 2 network, “fieldbus” with exchange rate and activity LED.
- 4 On **TM251MESG** controller: a connector for linking to the CANopen bus (9-way SUB-D).
- 5 SL serial link port (RS 232 or RS 485): RJ 45 connector.
- 6 Run/Stop switch.
- 7 TM4 bus connector: communication bus for linking to TM4 $\bullet\bullet\bullet$ communication modules.
- 8 Controller technical documentation QR code.
- 9 Modicon TM3 bus connector for linking to a Modicon TM3 expansion module.
- 10 LED display block showing: the status of the controller and its components (battery, SD memory card), the status of the embedded communication ports (Ethernet 1 and 2, CANopen, serial link).

Behind a cover **11, 12, 13**

- 11 Slot for the SD memory card.
- 12 Backup battery slot.
- 13 USB mini-B connector, marked “Prg. Port”, for connecting a programming terminal.
- 14 Lugs for screw mounting on panel.
- 15 Clip for locking on \perp symmetrical rail.

Characteristics of M251 logic controllers

Conformity

- Certifications
 - CE, cULus Listing Mark, C-Tick, EAC, LR, ABS, DNV and GL (1).

Standards

- IEC/EN 61131-2 (Edition 2 2007), UL 508 (UL 61010-2-201), ANSI/ISA 12.12.01-2007, CSA C22.2 No. 213, No.142, E61131-2 and IACS E10.

Environment characteristics

- Ambient operating temperature: - 10...+ 55°C (+14...+ 131°F).
- Storage temperature: - 40...+ 70°C (- 40...+ 158°F).
- Relative humidity: 5...95% (non-condensing).
- Operating altitude: 0...2,000 m (0...6,561 ft).
- Storage altitude: 0...3,000 m (0...9,842 ft).
- Immunity to mechanical stress:
 - For 1131: 5...8.4 Hz (amplitude 3.5 mm/0.138 in.); 8.4...150 Hz (acceleration 1 g).
 - For merchant marine: 5...13.2 Hz (amplitude 1.0 mm /0.039 in.); 13.2...100 Hz (acceleration 0.7 g).

Supply characteristics

- 24 V $\bar{\bar{}}$ power supply.
- Voltage limit (including ripple): 19.2...28.8 V $\bar{\bar{}}$.
- Immunity to micro-cuts (class PS-2): 10 ms.
- Max. consumption: 45 W.

(1) LR, ABS, DNV and GL marine certifications: pending.



TM251MESE



TM251MESC



TMASD1

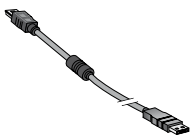

TCSXCNAMUM3P

References

Modicon M251 logic controllers (1)

| Description | Embedded communication ports | | | | Reference | Weight kg/ lb |
|---|--|-------------------------------------|---------------------------------|------------------------|-----------|---------------------|
| | Ethernet 1 "Machine" or "Factory" (RJ 45) | Ethernet 2 "Fieldbus" (RJ 45) | Master CANopen (9-way SUB-D) | Serial link (RJ 45) | | |
| 24 V \square power supply | | | | | | |
| M251 logic controllers | 2 (connected by a switch) | 1 | – | 1 | TM251MESE | 0.220/ 0.485 |
| | 2 (connected by a switch) | – | 1 | 1 | TM251MESC | 0.220/ 0.485 |

Options for Modicon M251 logic controllers

| Description | Details | Reference | Weight kg/ lb |
|----------------|---|-----------|---------------------|
| SD memory card | Application backup and program transfer Capacity: 256 MB | TMASD1 | 0.004/ 0.009 |

Replacement parts

| Description | Details | Reference | Weight kg/ lb |
|-------------------------------------|---|-----------|---------------------|
| Set of power supply terminal blocks | 8 removable screw terminal blocks | TMAT2PSET | 0.127/ 0.280 |
| Backup battery | The battery supplied with each controller is not available as a separate element Schneider reference. If necessary spare parts, use only a Panasonic BR2032 battery type. | | |

Programming software

| Description | Used for | Reference |
|--------------------|------------------------|--------------|
| SoMachine software | M251 logic controllers | See page 5/2 |

Expansion modules

| Description | Used for | Reference |
|-------------------------------|------------------------|---------------|
| Modicon TM3 expansion modules | M251 logic controllers | See page 3/20 |

Communication modules

| Description | Details | Reference |
|-----------------------------------|---|---------------|
| Modicon TM4 communication modules | Ethernet port module , Profibus DP slave module | See page 4/42 |

Cordsets

| Description | Use from | To | Length m/ft | Reference | Weight kg/ lb |
|--------------------|-------------|-------------------------------------|----------------|---------------------|---------------------|
| Programming cables | PC USB port | USB mini-B port on M251 controllers | 3/ 0.98 | TCSXCNAMUM3P (3) | 0.065/ 0.143 |
| | | | 1.8/ 5.90 | BMXXCAUSBH018 | 0.065/ 0.143 |

(1) M251 controllers are supplied with:

- a removable screw terminal block for connecting the power supply.
- a BR2032 button cell backup battery.

(2) Each M251 logic controller has an embedded USB mini-B programming port.

(3) Unshielded cable without grounding. To be used only for temporary connections. For permanent connections, use the reference BMXXCAUSBH018 programming cable.

Applications

General machine control:
 Packaging
 Conveying
 Hoisting
 ...

42 digital I/O | **42 digital I/O**



42 digital I/O + 4 analog inputs | **42 digital I/O + 4 analog inputs** | **42 digital I/O** | **66 digital I/O + 4 analog inputs**



User memory RAM
Flash

64 MB (program + data)
128 Mbytes

Typical Boolean instruction time

22 ns

User program size

128 program K instructions

Power supply

24 V ~

Channel connection

With removable spring terminal blocks (supplied)

Inputs Digital
Analog

26 x 24 V ~ inputs including 8 counter inputs (100 kHz)
-

Digital outputs Transistor
Relay

16 outputs (0.5 A) including 4 reflex outputs
-

Built-in communication ports USB-B mini-port
USB-A port
RJ45 port (MBS)
SUB-D connector (male 9-way) (CAN0)
RJ45 port (Ethernet)

Programming port for SoMachine software
Connection of a USB memory stick for transferring programs, data files, firmware updates
RS232 serial link, RS485 serial link (supplies 250 mA, 5 V for HMI power supply)
Protocols: Master/Slave Modbus ASCII/RTU, ASCII (character string)
- Master CANopen bus (63 slaves)
Ethernet TCP IP, Web Server, FTP, Ethernet Modbus TCP

Optional communication ports

-

Logic controller type

TM258LD42DT | **TM258LF42DT**

Pages

2/50

64 MB (program + data)
128 Mbytes

22 ns

128 program K instructions

24 V ~

With removable spring terminal blocks (supplied)

26 x 24 V ~ inputs including 8 counter inputs (100 kHz) | 38 x 24 V ~ inputs including 8 counter inputs (100 kHz)
4 inputs + 10 V/- 10 V, 4-20 mA/0-20 mA, 12-bit resolution | - | 4 inputs + 10 V/- 10 V, 4-20 mA/0-20 mA, 12-bit resolution

16 outputs (0.5 A) including 4 reflex outputs | 4 reflex outputs (0.5 A) | 28 outputs (0.5 A) including 4 reflex outputs
- | 12 | -

Programming port for SoMachine software
Connection of a USB memory stick for transferring programs, data files, firmware updates
RS232 serial link, RS485 serial link (supplies 250 mA, 5 V for HMI power supply)
Protocols: Master/Slave Modbus ASCII/RTU, ASCII (character string)
- Master CANopen bus (63 slaves)
Ethernet TCP IP Modbus slave, Web Server, FTP

2 PCI slots available on controller for optional communication modules TM5 PC... (1):
 Modbus or ASCII serial link
 connection to Profibus DP bus (slave)

TM258LD42DT4L | **TM258LF42DT4L** | **TM258LF42DR** | **TM258LF66DT4L**

2/50

(1) To be ordered separately, see page 4/10.



Modicon M258 logic controller

2

The Modicon M258 logic controller is a compact, high-performance and fully expandable PLC. It forms a part of Flexible Machine Control approach, a key component of MachineStruxure™, which brings flexibility and gives an optimised control solution.

This PLC is designed for machine manufacturers (OEMs) focusing on applications such as packaging, hoisting, conveying and storage, textiles and woodworking, hoisting, etc. It offers high-performance solutions for speed control, counting, axis control and communication functions.

Performance

In terms of performance, the Modicon M258 logic controller has a Dual-Core processor:

- Core 1 is dedicated exclusively to managing program tasks and offers the maximum resources for real-time execution of the application code.
- Core 2 is dedicated to executing communication tasks, which then have no further impact on the application execution performance.

With an execution speed of **22 ns** for a Boolean instruction i.e. more than **45,000 Boolean instructions** per ms, the capacity to manage up to **2400 I/O**, a **64 MByte** RAM memory that can store data and programs as well as a **128 MByte** Flash memory for application and data backup.

In developing the Modicon M258 logic controller, the cost aspect was taken into account, the CPUs are equipped as standard with:

- 42 or 66 digital I/O
- Embedded serial link and Ethernet port
- 4 analog inputs (TM258●●●●4L references)

Development and technology

The Modicon M258 logic controller has been developed to minimize the costs of assembly, cabling, commissioning and maintenance.

To this end:

- the modules have removable terminals.
- the electrical connections are made on spring terminals, speeding up the wiring process and also avoiding the need for periodic retightening. In addition, each terminal has a test point for a voltage sensing device.
- The embedded serial link and Ethernet port on the Modicon M258 logic controller have an RJ45 connection at 45° for quick visible connection of your communication channels.
- The modularity of the various bases and expansion modules has been optimized in order to reduce significantly the number of references to be ordered and assembled, while realizing a minimum investment in your configuration is necessary, thanks to a capacity of 2 to 42 channels per expansion module.
- Mechanical assembly of the various parts has been designed to save time during assembly.

Software configuration

Configuration and programming of M258 controllers and equipment in Schneider Electric's "Flexible Machine Control" concept are both designed to cut costs and optimize machine performance.

Schneider Electric's **SoMachine** software platform can be used to program M258 controllers using:

- IEC 61131-3 programming languages: Instruction List (IL), Ladder Diagram (LD), Function Block Diagram (FBD), Sequential Function Chart/Grafset (SFC) and Structured Text (ST)
- CFC (Continuous Function Chart) language.

PLCopen function blocks are used for managing motion control and axis control on your machines.

See page 5/2.

Integration in the Schneider Electric product offer

Combined with other products dedicated to machine manufacturers in the Schneider Electric offer, such as ATV variable speed drives, Lexium servo drives, Magelis HMI terminals, TeSys motor starters and contactors, the Modicon M258 logic controller is a must-have element in machine architectures.



SoMachine software platform

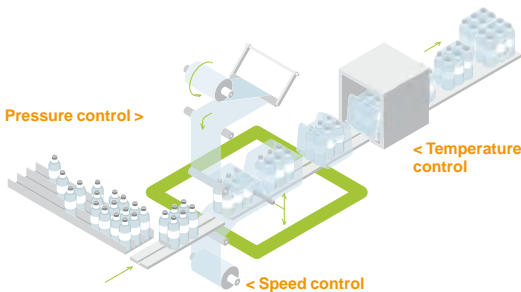

Analog functions

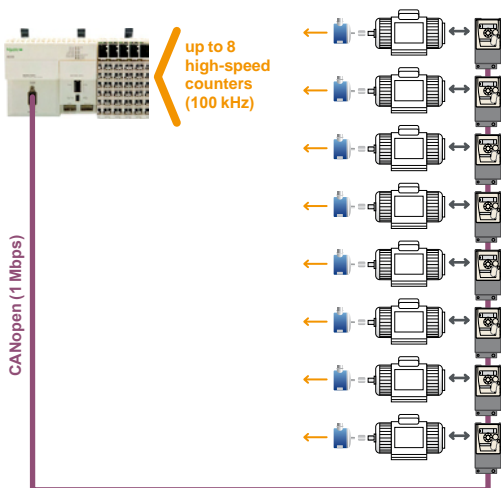

High-speed counter function (one-phase or two-phase)

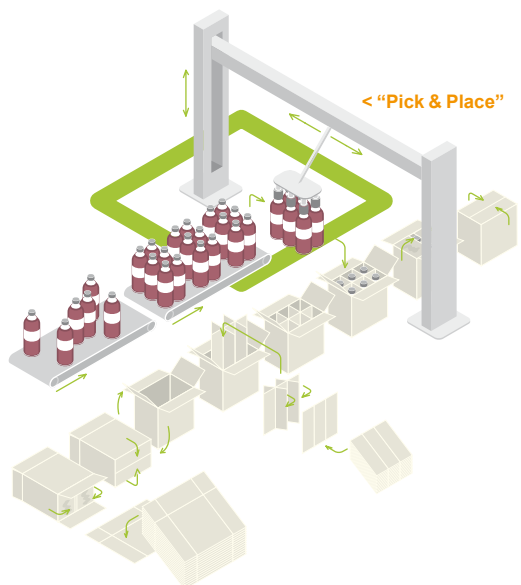

Position control function

Functions

Analog functions

For machines that require functions to process data issued by analog sensors/actuators (voltage or current), temperature sensors or PID control sensors, a complete range of expansion modules as well as advanced programming functions are included in the Modicon M258 logic controller offer.

In order to minimize the number of product references of your machines, optimize assembly time and cut costs, M258 logic controllers with the reference **TM258L●●●●4L** include as standard 4 voltage or current analog inputs with 12-bit resolution.

The different expansion modules are available in 2, 4, 6 or 8-channel versions and with either 12 or 16-bit resolution.

The powerful performance of the M258 logic controller enables up to 200 analog I/O and/or temperature modules to be connected, thus extending the limits of machine requirements.

High-speed counter function (HSC)

In order to meet requirements for machine productivity, the Modicon M258 logic controller has 8 embedded high-speed counters with a counting frequency of 100 kHz for each channel as well as 4 reflex outputs. The availability of these embedded counters and also the presence of the Master CANopen link in **TM258LF●●●●** controllers makes it quick and easy to create low-cost, high-performance multi-axis functions that suit the machines' limitations.

With the availability of "PLCopen" function blocks specific to the motion control functions in the SoMachine software, you can be sure that developing your applications will be quick and reliable.

Moreover, a complete range of high-speed counter modules is available so you can adapt your configuration to your machine's specific requirements.

Position control function

Several options are offered in terms of position control:

- Either creating a sequence in Lexium 32 servo drives, with communication with the M258 logic controller achieved by the use of digital I/O
- Or creating an application in the M258 logic controller and controlling Lexium 32 servo drives and/or SD3●● steppers via the integrated Master CANopen link available on **TM258LF●●●●** bases.

Communication functions

Ethernet

M258 logic controller references have an embedded RJ45 Ethernet port (10/100 Mbps, MDI/MDIX) with Ethernet TCP Modbus, Ethernet IP Device, SoMachine on Ethernet, UDP, TCP and SNMP protocols.

In addition, the M258 logic controllers have an embedded Web Server and FTP Server.

As well as the default address based on the MAC address, it is possible to assign a controller IP address via a DHCP server or via a BOOTP server.

CANopen

Depending on the reference, M258 logic controllers have an embedded CANopen master.

The link can be configured between 125 Kbps and 1 Mbps and supports up to 63 slaves.

Architectures based on CANopen can be used to distribute I/O modules as close to the sensors and actuators as possible, thus reducing wiring costs and times, and to communicate with different devices such as variable speed drives, servo drives, etc. The CANopen configurator is integrated in the SoMachine software and can also be used to import standard description files in EDS format.

Modbus serial link

M258 logic controllers have as standard a serial link that can be configured as either RS232/RS485 and incorporates two used protocols on the market:

- Master or Slave Modbus ASCII/RTU
- Character string (ASCII)

Profibus DP (Decentralized Peripherals)

The Modicon **TM258LD42DT4L**, **TM258LF42DT4L**, **TM258LF42DR** and **TM258LF66DT4L** logic controllers equipped with the **TM5PCDPS** communication module can be connected to Profibus bus: for controlling decentralized sensors, actuators or PLCs via a central master controller

2



TM258LD42DT logic controller



TM258LF42DT logic controller



TM258LD42DT4L logic controller

TM5PC communication modules



TM5C compact blocks



TM5SD digital modules



TM5SMM6D2L digital/Analog module



TM5SA and TM5SEAISG analog modules



TM5SE Expert modules



TM5SPD Common Distribution modules



TM5SPS Power Distribution modules



TM5SBET1 transmitter module



TM5SBER2 receiver module

Presentation

Range

The M258 logic controller range is divided into two controller sizes:

- TM258LD42DT and TM258LF42DT are 175 mm wide.
- TM258LD42DT4L, TM258LF42DT4L, TM258LF42DR, and TM258LF66DT4L are at least 237.5 mm wide as they have two free PCI slots for optional Modicon TM5 communication modules (Modbus or ASCII serial link, and connection to Profibus DP bus).

The M258 logic controller range is completed by an expansion module offer:

- Modicon TM5 Compact blocks
- Modicon TM5 Digital modules
- Modicon TM5 Digital/Analog module
- Modicon TM5 Analog modules
- Modicon TM5 Expert modules
- Modicon TM5 Common Distribution modules
- Modicon TM5 Power Distribution modules
- Modicon TM5 Transmitter and receiver modules

Functions

The main component in a system is the controller: 6 M258 logic controller models are offered to cover different control requirements (pressure, temperature, counting, speed, position control, motion, etc.).

M258 logic controllers and I/O modules are programmed with the SoMachine software.

| Reference | Embedded functions |
|---|---|
| TM258LD42DT, TM258LD42DT4L | <ul style="list-style-type: none"> ■ 42 digital I/O including 8 high-speed counters (100 kHz) ■ Depending on the reference, 4 voltage/current analog inputs can be added |
| TM258LF42DT, TM258LF42DT4L, TM258LF42DR, TM258LF66DT4L | <ul style="list-style-type: none"> ■ 42 or 66 digital I/O including 8 high-speed counters (100 kHz) ■ Depending on the reference, 4 voltage/current analog inputs can be added ■ Up to 16 independent axes ■ CANopen master |

M258 controllers have two groups of high-speed I/O with, for each group:

- Four sink type high-speed inputs (up to 100 KHz), 2 standard inputs and 2 source type high-speed outputs (up to 100 KHz) dedicated to HSC or PWM functions
- A high-speed input which can be used as an "Encoder capture input"
- Two commons for the inputs
- One common for the outputs
- A power supply (24 V $\overline{\text{---}}$) consisting of 3 units:
 - One for the CPU
 - One for the high-speed I/O modules
 - One for other modules (internal I/O Bus)

Conformity to standards

| Type | | Performance |
|--------------------------------|------------------------|--|
| Surge immunity 24 VDC circuit | EN/IEC 61000-4-5 | 1 kV in common mode |
| | | 0.5 kV in differential mode |
| Surge immunity 230 VAC circuit | EN/IEC 61000-4-5 | 2 kV in common mode |
| | | 1 kV in differential mode |
| Induced electromagnetic field | EN/IEC 61000-4-6 | 10 Veff (0.15...80 MHz) |
| Conducted emission | EN 55011 (IEC/CISPR11) | 150...500 kHz, quasi peak 79 dB μ V |
| | | 500 kHz...30 MHz, quasi peak 73 dB μ V |
| Radiated emission | EN 55011 (IEC/CISPR11) | 30...230 MHz, 10 m @ 40 dB μ V/m |
| | | 230 MHz...1 GHz, 10 m @ 47 dB μ V/m |

Assembly and mounting

The components of this system have been designed for simple interlocking mechanical assembly.
 An 8-way expansion bus connection (2 for the power supply, 2 for the bus and 4 for the data) is used to distribute data and the power supply when assembling the components: the M258 controller with compact blocks and modules (digital, digital/analog, analog, Expert, common distribution, power distribution, expansion bus). The elements which make up the system are mounted and dismounted on a symmetrical rail using the locking levers located on top of each device.

Wiring and maintenance of devices is simplified since they are fitted with removable spring terminals. The spring terminals are undone by pressing a locking tab.

The system is integrated into communication networks: the connectors (RJ45, USB, mini-USB and SUB-D type depending on the model) are accessible, as they are located on the controller front panels.

Local or remote architecture

Local I/O

A PLC configuration can be local or remote. It consists of an M258 controller with its embedded input and output channels, used in conjunction with compact blocks and/or modules which are used to increase the number of channels and/or "Application-specific" functions.

- Compact blocks represent a way of adding a large number of I/O with a single reference. This possibility reduces both the cost per channel, and also assembly times. These compact blocks are available in 4 references offering a high level of flexibility in configurations.
- I/O modules (a combination of a bus base, an electronic module and a terminal block) complete this configuration and, being modular with between 2 and 12 channels, make it possible to adjust the number of channels to exactly that required. Addition of digital or analog modules, temperature or high-speed modules increases the processing capabilities of applications.

Configuration of local I/O

- 1 XBTGT supervision graphic touch screen terminal
- 2 M258 controller
- 3 Compact blocks or I/O modules

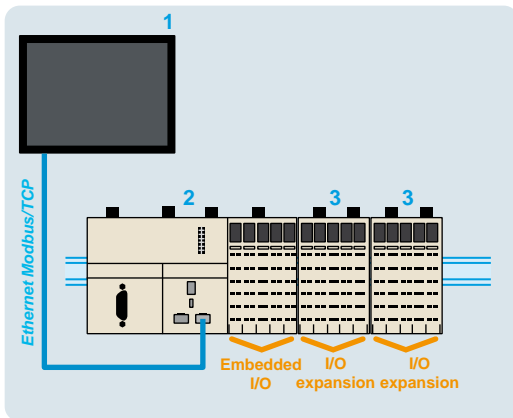

Local I/O

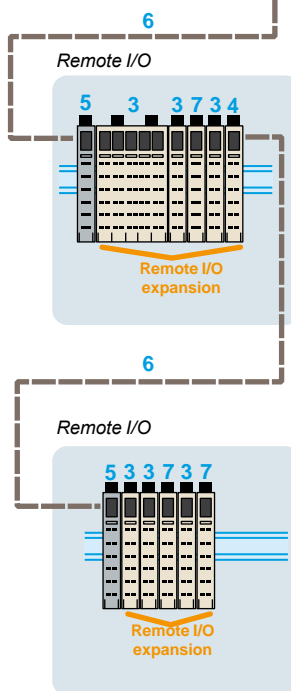
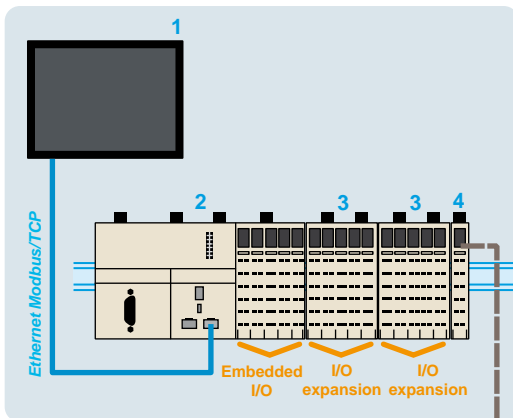

Remote I/O

Because of its backplane bus management, the TM5 system can be used to control I/O remotely.

The same modules can be used in either a local and/or remote configuration, linked together with expansion bus cables.

The total maximum distance between 2 remote islands is 100 m and the maximum number of islands is 25, i.e. a total distance of up to 2500 m.

This function gives a high level of flexibility, while retaining **synchronization of data acquisition**, since the expansion modules are on the same backplane bus.

Configuration of remote I/O

- 1 XBTGT supervision graphic touch screen terminal
- 2 M258 controller
- 3 Compact blocks or I/O modules
- 4 Transmitter modules
- 5 Receiver modules
- 6 TM5 expansion bus cables
- 7 Common distribution modules

Communication

M258 logic controllers have the following built-in communication ports:

| References | Communication ports | Use |
|---|--|--|
| TM258LD42DT, TM258LD42DT4L | RJ45 Configurable as RS232 or RS485 | ASCII or RTU exchange with Modbus communication protocol |
| | 1 x RJ45 (MDI/MDIX port) | <input type="checkbox"/> FTP server <input type="checkbox"/> Web server <input type="checkbox"/> Modbus TCP server <input type="checkbox"/> Modbus TCP client <input type="checkbox"/> Manager SoMachine <input type="checkbox"/> SNMP <input type="checkbox"/> Ethernet IP device <input type="checkbox"/> Modbus device |
| | 1 x USB-A | Connection of a USB memory stick for transferring (uploading/downloading) programs, data and/or firmware |
| | 1 x mini-USB | Programming port (480 Mbps) |
| | 2 PCI slots for communication modules = 2 x 9-way male SUB-D | Addition of optional communication modules for a serial link and a connection on the bus Profibus DP (1) |
| TM258LF42DT, TM258LF42DT4L, TM258LF42DR, TM258LF66DT4L | 1 x RJ45 Configurable as RS232 or RS485 | ASCII or RTU exchange with Modbus communication protocol |
| | 1 x RJ45 (MDI/MDIX port) | <input type="checkbox"/> FTP server <input type="checkbox"/> Web server <input type="checkbox"/> Modbus TCP server <input type="checkbox"/> Modbus TCP client <input type="checkbox"/> Manager SoMachine <input type="checkbox"/> SNMP <input type="checkbox"/> Ethernet IP device <input type="checkbox"/> Modbus device |
| | 1 x USB-A | Connection of a USB memory stick for transferring (uploading/downloading) programs, data and/or firmware |
| | 1 x mini-USB | Programming port (480 Mbps) |
| | 1 x 9-way male SUB-D | Master CANopen connection |
| | 2 PCI slots for communication modules = 2 x 9-way male SUB-D | Addition of optional communication modules for a serial link and a connection on the bus Profibus DP (2) |

Embedded Ethernet

M258 logic controllers have an embedded Ethernet link via a direct connection to their RJ45 port.

- Speed: "10 BaseT" and "100 BaseTX" with auto-negotiation
- RJ45 port (MDI/MDIX): automatic adaptation to a straight or crossed cable

| References | Protocols | Number of connections |
|---|--------------------|-----------------------|
| TM258LD42DT, TM258LD42DT4L, TM258LF42DT, TM258LD42DT4L, TM258LF42DR, TM258LF66DT4L | Modbus server | 8 |
| | Modbus device | 2 |
| | SoMachine | 3 (3) |
| | Ethernet IP device | 16 |
| | FTP server | 4 |
| | Web server | 10 |

(1) Only on TM258LD42DT4L.
 (2) Only on TM258LF42DT4L, TM258LF42DR and TM258 LF66DT4L.
 (3) The Oscilloscope function uses one connection.

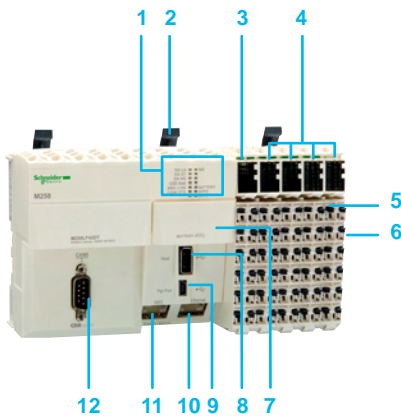

Description

The **TM258LD42DT** and **TM258LF42DT** logic controllers comprise:

- 1 A display block with:
 - 4 controller status LEDs (RUN/MS, BATTERY, APP0 and APP1)
 - 6 built-in communication port status LEDs (*Eth* LA, *Eth* ST, *Eth* NS, USB Host, MBS COM, CAN 0 STS)
- 2 Locking lever for mounting/dismounting on \perp symmetrical rail.
- 3 A 24 V $\overline{\text{---}}$ power supply module with removable terminal block and locking lever, display block and slot for a label.
- 4 I/O modules, each one with: a removable terminal block with locking lever, a display block showing the I/O states and a slot for a label-holder.
- 5 Removable terminal block with locking lever for locking/unlocking.
- 6 On the side, an expansion bus connection for the link with the next module.
- 7 A slot for the RTC (Real Time Clock) battery.
- 8 A USB-A connector (marked Host) for connection of a USB memory stick for transferring programs, data or firmware updates.
- 9 A USB-B mini-connector (marked Pgr Port) for connection to the programming PC
- 10 An RJ45 connector (marked Ethernet) for connection to the Ethernet network and/or connection to the Magelis XBT GT graphic terminal.
- 11 An RJ45 connector (marked MBS) for the RS232 or RS485 serial link.
- 12 A 9-way male SUB-D connector, marked CAN 0, for connection to the CANopen bus (TM258 LF42DT only).

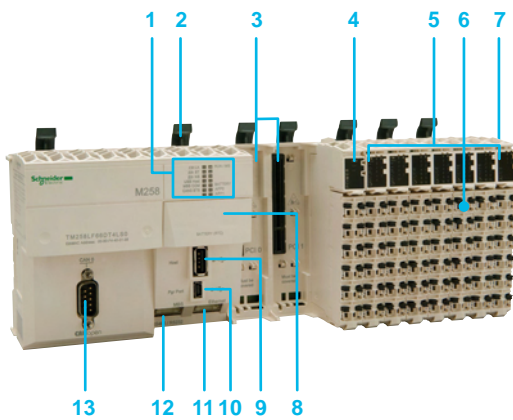

The **TM258LD42DT4L/LF42DT4L/LF42DR/LF66DT4L** logic controllers comprise:

- 1 A display block with:
 - 4 controller status LEDs (RUN/MS, BATTERY, APP0 and APP1)
 - 6 built-in communication port status LEDs (*Eth* LA, *Eth* ST, *Eth* NS, USB Host, MBS COM, CAN 0 STS)
- 2 Locking lever for mounting/dismounting on \perp symmetrical rail.
- 3 Two free PCI slots for the communication module.
- 4 A 24 V $\overline{\text{---}}$ power supply module with removable terminal block and locking lever, display block and slot for a label.
- 5 I/O modules, each one with: a removable terminal block with locking lever, a display block showing the I/O states and a slot for a label-holder.
- 6 Removable terminal block with locking lever for locking/unlocking.
- 7 On the side, an expansion bus connection for the link with the next module.
- 8 A slot for the RTC (Real Time Clock) battery.
- 9 A USB-A connector (marked Host) for connection of a USB memory stick for transferring programs, data or firmware updates.
- 10 A USB-B mini-connector (marked Pgr Port) for connection to the programming PC.
- 11 An RJ45 connector (marked Ethernet) for connection to the Ethernet network and/or connection to the Magelis XBT GT graphic terminal.
- 12 An RJ45 connector (marked MBS) for the RS232 or RS485 serial link.
- 13 A 9-way male SUB-D connector, marked CAN 0, for connection to the CANopen bus (TM258LF42DT4L, TM258LF42DR and TM258LF66DT4L only).

References

Logic controllers, 24 V $\overline{\text{---}}$ power supply (1)

TM258LD42DT



TM258LF42DT



TM258LD42DT4L



TM258LF42DT4L



TM258LF42DR



TM258LF66DT4L

| Nbr. of I/O | Inputs | Outputs | Built-in communication ports | Reference | Weight kg/ lb |
|-------------|---|---|--|----------------------|---------------------|
| 42 I/O | <ul style="list-style-type: none"> ■ 26 x 24 V $\overline{\text{---}}$ digital inputs including 8 counter inputs (100 kHz) | <ul style="list-style-type: none"> ■ 16 transistor digital outputs (0.5 A) including 4 reflex outputs | <ul style="list-style-type: none"> <input type="checkbox"/> 1 RJ45 port: Ethernet <input type="checkbox"/> 1 USB-A port: program transfer <input type="checkbox"/> 1 USB-B mini-port: software programming <input type="checkbox"/> 1 RJ45 port: RS232/RS485 serial link | TM258LD42DT | 0.500/ 1.102 |
| | | | <ul style="list-style-type: none"> <input type="checkbox"/> 1 RJ45 port: Ethernet <input type="checkbox"/> 1 SUB-D port (9-way male): CANopen master <input type="checkbox"/> 1 USB-A port: program transfer <input type="checkbox"/> 1 USB-B mini-port: software programming <input type="checkbox"/> 1 RJ45 port: RS232/RS485 serial link | TM258LF42DT | 0.550/ 1.213 |
| 42 + 4 I/O | <ul style="list-style-type: none"> ■ 26 x 24 V $\overline{\text{---}}$ digital inputs including 8 counter inputs (100 kHz) ■ 4 analog inputs 10 V/- 10 V, 4-20 mA/0-20 mA, 12-bit resolution | <ul style="list-style-type: none"> ■ 16 digital transistor outputs (0.5 A) including 4 reflex outputs | <ul style="list-style-type: none"> <input type="checkbox"/> 1 RJ45 port: Ethernet <input type="checkbox"/> 1 USB-A port: program transfer <input type="checkbox"/> 1 USB-B mini-port: software programming <input type="checkbox"/> 1 RJ45 port: RS232/RS485 serial link | TM258LD42DT4L | 0.770/ 1.698 |
| | | | <ul style="list-style-type: none"> <input type="checkbox"/> + 2 free PCI slots for optional communication module (2): RS232/RS485 serial link and Profibus DP bus | TM258LF42DT4L | 0.770/ 1.698 |
| 42 I/O | <ul style="list-style-type: none"> ■ 26 x 24 V $\overline{\text{---}}$ digital inputs including 8 counter inputs (100 kHz) | <ul style="list-style-type: none"> ■ 4 digital transistor (reflex) outputs (0.5 A) ■ 12 relay outputs | <ul style="list-style-type: none"> <input type="checkbox"/> 1 RJ45 port: Ethernet <input type="checkbox"/> 1 SUB-D port (9-way male): CANopen master <input type="checkbox"/> 1 USB-A port: program transfer <input type="checkbox"/> 1 USB-B mini-port: software programming <input type="checkbox"/> 1 RJ45 port: RS232/RS485 serial link | TM258LF42DR | 0.800/ 1.764 |
| | | | <ul style="list-style-type: none"> <input type="checkbox"/> + 2 free PCI slots for optional communication modules (2): RS232/RS485 serial link and Profibus DP bus | | |
| 66 + 4 I/O | <ul style="list-style-type: none"> ■ 38 x 24 V $\overline{\text{---}}$ digital inputs including 8 counter inputs (100 kHz) ■ 4 analog inputs + 10 V/- 10 V, 4-20 mA/0-20 mA, 12-bit resolution | <ul style="list-style-type: none"> ■ 28 digital transistor outputs (0.5 A) including 4 reflex outputs | <ul style="list-style-type: none"> <input type="checkbox"/> 1 RJ45 port: Ethernet <input type="checkbox"/> 1 SUB-D port (9-way male): CANopen master <input type="checkbox"/> 1 USB-A port: program transfer <input type="checkbox"/> 1 USB-B mini-port: software programming <input type="checkbox"/> 1 RJ45 port: RS232/RS485 serial link | TM258LF66DT4L | 0.800/ 1.764 |
| | | | <ul style="list-style-type: none"> <input type="checkbox"/> + 2 free PCI slots for optional communication modules (2): RS232/RS485 serial link and Profibus DP bus | | |

(1) The Modicon M258 logic controllers require a power supply with a nominal voltage of 24 V $\overline{\text{---}}$, Separated Extra Low Voltage (SELV-rated) according to IEC 61140.

The SELV-rating means that SELV isolation is provided between the electrical input and output of the power supply.

(2) To be ordered separately see page 4/10.

| References | | | | | | |
|--|--|-----------------------------------|-----------------|----------------|--------------|--|
| Accessories | | | | | | |
| Type | Used for | Colour | Sold in lots of | Unit reference | Weight kg/lb | |
| Plain text cover holder (label-holder) | Marking the terminal blocks on the I/O channels | Transparent | 100 | TM5ACTCH100 | 0.002/0.004 | |
| Plain text cover holder locking clip (Order with plain text cover holder TM5ACTCH100) | Locking plain text cover holder TM5ACTCH100 | Transparent | 100 | TM5ACTLC100 | 0.001/0.002 | |
| Precut legend strips of paper | Plain text cover holder TM5ACTCH100 | White | 100 | TM5ACTLS100 | 0.001/0.002 | |
| Coloured plastic identifiers | Labelling 16 connection channel terminals | White | 1 | TM5ACLITW1 | 0.015/0.033 | |
| | | Red | 1 | TM5ACLITR1 | 0.015/0.033 | |
| | | Blue | 1 | TM5ACLITB1 | 0.015/0.033 | |
| Metal tool | Inserting/removing TM5ACLIT●1 identifiers | Black | 1 | TM5ACLT1 | 0.030/0.066 | |
| Connection cables | | | | | | |
| Description | Use from | to | Length m/ft | Reference | Weight kg/lb | |
| Software programming cable Baud rate: 480 Mbps max. Protocol: Modbus, HTTP, FTP, Codesys or virtual, non-isolated | PC USB port | USB mini-port on M258 controllers | 3/9.84 | TCSXCNAMUM3P | 0.065/0.143 | |
| RS485 serial link cables Modbus protocol | SUB-D port (25-way) on Small Panel compact display units: XBT N401, XBT N410, XBT R410, XBT R411, XBT GT2... GT7 | RJ45 port on M258 controllers | 1.8/5.90 | XBTZ938 | 0.230/0.507 | |
| | RJ45 port on XBT GT graphic touch screen terminals | RJ45 port on M258 controllers | 2.5/8.20 | XBTZ9980 | 0.230/0.507 | |
| RS232 serial link cables Character mode | SUB-D port (9-way female) on DTE equipment (1): printer, hand-held bar code reader, etc. | RJ45 port on M258 controllers | 3/9.84 | TCSMCN3M4F3C2 | 0.150/0.331 | |
| | SUB-D port (9-way female) on DCE equipment (2): GSM modem | RJ45 port on M258 controllers | 3/9.84 | TCSMCN3M4M3S2 | 0.150/0.331 | |

(1) DTE: Data Terminal Equipment.

(2) DCE: Data Communication Equipment.

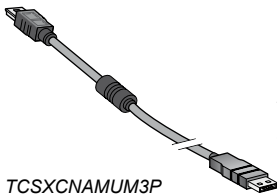
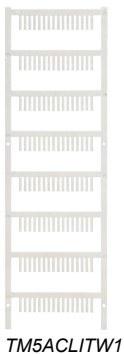

Applications

General machine control with motion:

- Packaging
- Conveying
- ...

42 digital I/O



User memory RAM
Flash

64 MB (program + data)
128 MB

Typical Boolean instruction time

22 ns

User program size

128 program Kinstructions

Power supply

24 V ---

Channel connection

Via removable spring terminal blocks (supplied)

Inputs Digital
Analog

26 x 24 V --- inputs including 8 counter inputs (100 kHz)
--

Digital outputs Transistor
Relay

16 outputs (0.5 A) including 4 reflex outputs
--

Built-in communication ports USB-B mini-port
USB-A port
RJ45 port (MBS)
SUB-D connector (9-way male) (CAN0)
SUB-D connector (9-way male) (CAN1)
SUB-D connector (15-way female) (Encoder)
RJ45 port (Ethernet)

Programming port for SoMachine V2.0 software
Connection of a USB memory stick for transferring programs, data files, firmware updates
RS232 serial link
RS485 serial link (supplies 250 mA, 5 V for HMI power supply)
Protocols: Modbus ASCII/RTU Master/Slave, ASCII (character string)
CANopen bus master (63 slaves)
CANmotion bus master (8 synchronized axis or 63 slaves)
Encoder input (incremental or SSI)
Ethernet TCP IP, Web Server, FTP, Ethernet Modbus TCP

Optional communication ports

--

Motion controller type

LMC058LF42

Pages

2/62

General machine control with motion:

- Packaging
- Conveying
- Machine control with motion

**42 digital I/O
+ 4 analog inputs**



64 MB (program + data)
128 MB

22 ns

128 program Kinstructions

24 V ---

Via removable spring terminal blocks (supplied)

26 x 24 V --- inputs including 8 counter inputs (100 kHz)
4 inputs
+ 10 V/- 10 V, 4-20 mA/0-20 mA
12-bit resolution

16 outputs (0.5 A) including 4 reflex outputs
--

Programming port for SoMachine V2.0 software
Connection of a USB memory stick for transferring programs, data files, firmware updates
RS232 serial link,
RS485 serial link (supplies 250 mA, 5 V for HMI power supply)
Protocols: Modbus ASCII/RTU Master/Slave, ASCII (character string)
CANopen bus master (63 slaves)
CANmotion bus master (8 synchronized axis or 63 slaves)
Encoder input (incremental or SSI)
Ethernet TCP IP Modbus slave, Web Server, FTP

2 PCI slots available on controller for optional communication modules TM5PC●●● (1):
 Modbus or ASCII serial link
 connection to Profibus DP bus (slave)

LMC058LF424

2/62

(1) To be ordered separately, see page 4/10.



Modicon LMC058 motion controller

2

The Modicon LMC058 motion controller is the optimum solution for axis control and positioning, including automation functions. It forms a part of Flexible Machine Control approach, a key component of MachineStruxure™, which brings you maximum flexibility and ensures the most optimised control solution. The Modicon LMC058 motion controller meets the needs of a wide range of applications in several business sectors.

This motion controller is designed for machine manufacturers (OEMs) who require synchronized axes, focusing on applications such as packaging, conveying and storage machines, metal and wood working machines, etc. and offers high-performance solutions for velocity control, counting, axis control and communication functions.

To this end, the LMC058 master motion controller includes as standard:

- A CANopen master
- A CANmotion master dedicated to control of up to 8 synchronized axes, with a performance of 2 ms for 4 axes

With Motion controllers Modicon LMC058, Lexium 32 and Lexium SD3 drives, and BSH and BDH servo motors, Schneider Electric offers a complete, high-performance and cost-effective solution.

Applications

The Modicon LMC058 motion controller performs axis synchronization and coordination, via a fieldbus, for applications requiring control of up to 8 synchronized axes.

It integrates the standard motion control functions:

- Velocity control and torque control
- Relative or absolute positioning
- Cam profiles for slave axes and control of programmable cam switches
- Virtual axes
- Electronic gearing function for velocity and position, linear and circular interpolations (2½D)
- Master axis using an external encoder
- Distance measurement and position capture on high-speed (30 µs) digital input

This is specifically designed for applications such as:

- Material handling machines (conveyors, palletizers, storage and retrieval systems, etc.) and transfer machines (cranes, etc.)
- Assembly machines (tool fixing, clamping, etc.)
- Inspection and quality control machines
- Packaging machines working "on the fly" (flying shear, printing, marking, etc.)
- Wood and metal working machines

Performance

In terms of performance, the Modicon LMC058 motion controller has a Dual-Core processor:

- Core 1 is dedicated exclusively to managing program tasks and offers the maximum resources for real-time execution of synchronized axis control and the application code.
- Core 2 is dedicated to executing communication tasks, which then have no further impact on the application execution performance.

Execution of the Motion task is synchronized with the CANmotion bus cycle time. This task calculates the position of the synchronized axes and is programmed with SoMachine software, which is used to program Modicon LMC058 motion controller using:

- IEC 61131-3 programming languages: Instruction List (IL), Ladder Diagram (LD), Function Block Diagram (FBD), Sequential Function Chart/Grafset (SFC) and Structured Text (ST)
- CFC (Continuous Function Chart) language.

See page 5/2.

The ease of use of PLCopen function blocks significantly reduces the time taken to program motion control and control independent and synchronized axes on machines.

The ability to combine motion functions with standard automation functions offers both maximum flexibility and a high level of performance. The LMC058 master motion controller is able to control synchronization of real, remote and virtual axes.



SoMachine software platform

Performance (continued)

To improve the performance and reliability of your machines, the LMC058 motion controller has a 15-way SUB-D connection for a master encoder (incremental or SSI).

With an execution speed of **22 ns** for a Boolean instruction i.e. more than **45,000 Boolean instructions** per ms, the capacity to manage up to **2400 I/O**, a **64 MB RAM** that can store data and programs as well as a **128 MB Flash** memory for application and data backup, the Modicon LMC058 motion controller greatly enhances the machine's capabilities.

In developing the Modicon LMC058 motion controller, the cost aspect was taken into account, and the CPUs are equipped as standard with:

- 42 digital I/O
- Embedded serial link and Ethernet port
- 4 analog inputs (reference LMC058LF424)
- A CANopen master
- A CANmotion master

Development and technology

In its characteristics, the Modicon LMC058 motion controller has been developed to minimize the costs of assembly, cabling, commissioning and maintenance.

To this end:

- Each module have removable terminals.
- The electrical connections are made on spring terminals, speeding up the wiring process and also avoiding the need for periodic retightening. In addition, each terminal has a test point for a voltage sensing device.
- The embedded serial link and Ethernet port on the Modicon LMC058 motion controller have an RJ45 connection at 45° for quick visible connection of the communication channels.
- The modularity of the various bases and expansion modules has been optimized in order to significantly reduce the number of references to be ordered and assembled, while ensuring the minimum investment in your configuration is necessary, thanks to a capacity of between 2 and 42 channels per expansion module.
- Mechanical assembly of the various parts has been designed to save a considerable amount of time during assembly.

Software configuration

Configuration and programming of each Modicon LMC058 motion controller and equipment in Schneider Electric's "Flexible Machine Control" concept are both designed to cut costs and optimize machine performance, using SoMachine.

To reduce the configuration time of device, a selection of function blocks is available in the "Motion Library":

- Library for ATV on CANopen
- Lexium library for Lexium 32 and Lexium SD3 on CANopen and CANmotion
- Lexium library for the whole ILx range on CANopen

This PLCopen-compliant library consists of administrative function blocks (read/write parameters, states, etc.) and single-axis and multi-axis function blocks.

The main functions are as follows:

- Power On, stop, reset
- Relative, absolute or additional positioning
- Continuous positioning (reaching a position at a predefined speed)
- Velocity control
- Velocity profile
- Position profile
- Cam profile
- Electronic gearing
- Phasing
- Programmable cam switch
- Linear or circular interpolation

User library

With SoMachine software, it is very easy to create your own function blocks (user library) to reduce programming times. Creating a user library simplifies the standardization and reuse of programs and also allows the user to protect proprietary information.

Application function blocks (AFB)

This is a library of functions developed specifically by Schneider Electric. It contains application functions currently encountered in applications in the fields of assembly, material handling and cut to length applications. Each function block has a large number of mechanical and application variants.

The use of function blocks:

- Saves programming time
- Saves setup time
- Simplifies reading

The function blocks available in the library are:

- Flying shear
- Rotary knife
- Grouping/ungrouping
- Clamping with torque control
- Etc.

Functions

Analog functions

For machines that require functions to process data issued by analog sensors/ actuators (voltage or current), temperature sensors or PID control sensors, a complete range of expansion modules as well as advanced programming functions are included in the Modicon LMC058 motion controller offer.

In order to minimize the number of machine product references, optimize assembly time and cut costs, the LMC058LF424 motion controller includes 4 voltage or current analog inputs with 12-bit resolution as standard.

The different expansion modules are available in 2, 4 or 6-channel versions and with either 12 or 16-bit resolution.

The powerful performance of the LMC058 motion controller enables up to 200 analog I/O and/or temperature modules to be connected, thus extending the limits of machine requirements.

High-speed counter function (HSC)

In order to meet requirements for machine productivity, the LMC058 motion controller has 8 embedded high-speed counters with a counting frequency of 200 kHz for each channel and 4 reflex outputs.

These embedded counters, together with the CANopen master link, make it quick and easy to create cost-effective, high-performance multi-axis functions to suit the machines' limitations.

With the availability of PLCopen function blocks specific to the motion control functions in the SoMachine software, you can be sure that developing your applications will be quick and reliable.

Moreover, a complete range of high-speed counter modules is available so you can adapt your configuration to your machine's specific requirements.

Position control function

Several options are offered in terms of position control:

- Creating a sequence in Lexium 32 servo drives, with communication with the LMC058 motion controller achieved by the use of digital I/O
- Creating an application in the LMC058 motion controller and controlling Lexium 32 drives and servo drives and/or Lexium SD3 stepper drives via the integrated CANopen master link available on LMC058 motion controllers (in this case the Motion tasks are independent axis Motion tasks)
- Creating an application in the LMC058 motion controller and controlling the Lexium 32 drives and servo drives and/or Lexium SD3 stepper drives via the integrated CANmotion master link available on each LMC058 motion controller (in this case the Motion tasks are independent and/or synchronized axis Motion tasks - cam profiles, electronic gearing, interpolation)

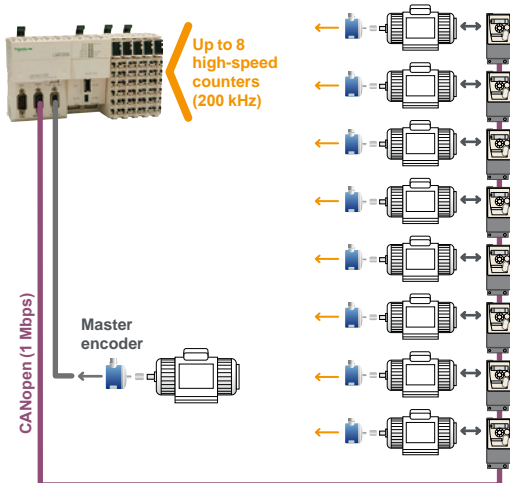

High-speed counter function (one-phase or two-phase)

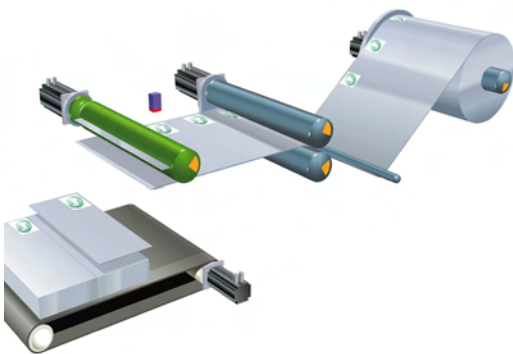

Lexium 32 servo drives: monitoring cutting to length

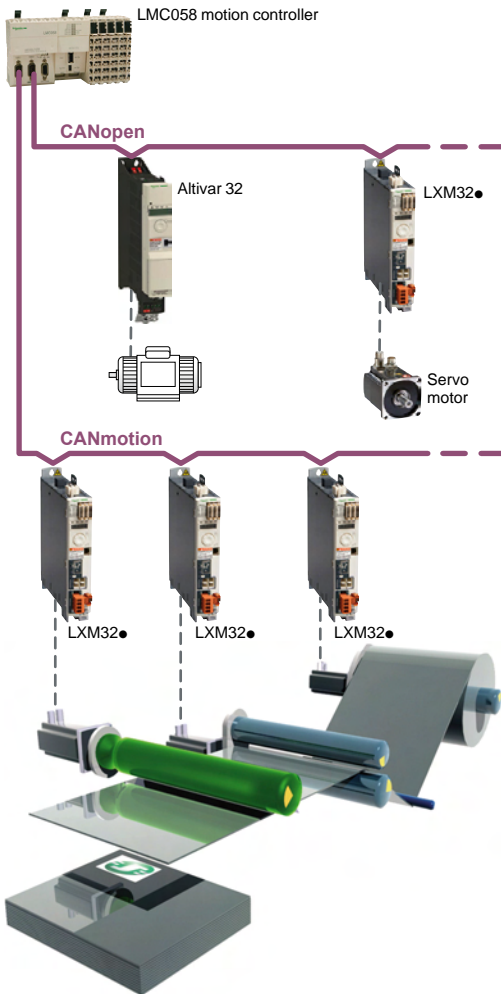

Ethernet communication

Each Modicon LMC058 motion controller reference have an embedded RJ45 Ethernet port (10/100 Mbps, MDI/MDIX) with Ethernet TCP Modbus, Ethernet IP Device, SoMachine on Ethernet, UDP, TCP and SNMP protocols.

In addition, each LMC058 motion controller has an embedded Web Server and FTP Server. As well as the default address based on the MAC address, it is possible to assign a motion controller IP address via a DHCP server or BOOTP server.

CANmotion/CANopen communication

The CANopen machine bus is now very widely used in industry because of its high performance. In accordance with international standard ISO 11898 promoted by the CAN in Automation association of users and manufacturers, it offers a high level of openness and interoperability thanks to its standardized communication and equipment profiles.

CANmotion and CANopen buses use a double shielded twisted pair. Each end of the bus must be equipped with a line terminator.

A staged CANmotion and CANopen connectivity solution reduces costs and optimizes your architecture, thanks to:

- Reduced cabling time
- Greater reliability of the cabling
- Flexibility should you need to add or remove a device

CANmotion

Each Modicon LMC058 motion controller reference has an embedded CANmotion master.

This bus is dedicated to synchronizing the drives (conforming to standard CiA DSP 402, the Device Profile for Drives & Motion Control).

This CANmotion link can be configured between 250 kbps and 1 Mbps, and offers the option of configuring and controlling up to 8 Lexium 32 servo drives and/or Lexium SD3 stepper drives.

The CANmotion bus cycle time ensures that the axis positions will be refreshed. To ensure maximum performance on the motion bus, we recommend using a daisy chain cabling architecture.

CANopen

Each Modicon LMC058 motion controller references has an embedded CANopen master.

This bus is dedicated to expansion of the automation capabilities, such as the I/O, drives, encoders, etc.

The link can be configured between 125 kbps and 1 Mbps and supports up to 63 slaves. Architectures based on CANopen can be used to distribute I/O modules as close to the sensors and actuators as possible, thus reducing wiring costs and times, and to communicate with different devices such as variable speed drives, servo drives, etc.

The CANopen configurator is integrated in the SoMachine software and can also be used to import standard description files in EDS format.

Modbus communication

Each Modicon LMC058 motion controller has a serial link as standard that can be configured as either RS232 or RS485 and incorporates the two of the most commonly used protocols on the market:

- Modbus ASCII/RTU Master or Slave
- Character string (ASCII)

Profibus DP (Decentralized Peripherals)

The Modicon LMC 058LF424 motion controller equipped with the **TM5PCDPS** communication module can be connected to Profibus bus for controlling decentralized sensors, actuators or PLCs via a central master controller.

Integration in the Schneider Electric product offer

Combined with other products dedicated to machine manufacturers in the Schneider Electric offer, such as ATV variable speed drives, Lexium servo drives, Magelis HMI terminals, TeSys motor starters and contactors, the Modicon LMC058 motion controller is now a must-have element in machine architectures, with hitherto unrivalled ease and speed of installation.

2



LMC058LF42 motion controller



LMC058LF424 motion controller

TM5PC communication modules



TM5C compact block



TM5SD digital module



TM5SMM6D2L digital/analog module



TM5SA analog module



TM5SE Expert module



TM5SPD Common Distribution module



TM5SPS Power Distribution modules



TM5SBET1 transmitter module



TM5SBER2 receiver module

Presentation

Range

The LMC058 motion controller range is divided into two sizes:

- The LMC058LF42 motion controller is 177 mm wide.
- The LMC058LF424 motion controller is 237.5 mm wide as it has two free PCI slots for optional Modicon TM5 communication modules (Modbus or ASCII serial link, connection to Profibus DP bus).

This range is completed by an extensive expansion module offer:

- Modicon TM5 Compact blocks
- Modicon TM5 Digital modules
- Modicon TM5 Digital/Analog module
- Modicon TM5 Analog modules
- Modicon TM5 Expert modules
- Modicon TM5 Common Distribution modules
- Modicon TM5 Power Distribution modules
- Modicon TM5 Transmitter and receiver modules

Functions

The main component in a system is the motion controller: two LMC058 motion controller models are offered to cover different control requirements (pressure, temperature, counting, velocity, positioning, motion, etc.).

LMC058 motion controllers and I/O modules are programmed using SoMachine software.

| Reference | Embedded functions |
|-------------|---|
| LMC058LF42 | <ul style="list-style-type: none"> ■ 42 digital I/O including 8 high-speed counters (200 kHz) ■ CANopen master ■ CANmotion master |
| LMC058LF424 | <ul style="list-style-type: none"> ■ 42 digital I/O including 8 high-speed counters (200 kHz) ■ 4 voltage/current analog inputs ■ CANopen master ■ CANmotion master |

The Modicon LMC058 motion controllers have two groups of high-speed I/O with, for each group:

- Four sink type high-speed inputs (up to 200 kHz), 2 standard inputs and 2 source type high-speed outputs (up to 100 kHz) dedicated to HSC or PWM functions
- A high-speed input which can be used as an "Encoder capture input"
- Two commons for the inputs
- One common for the outputs
- A power supply (24 V \pm) consisting of 3 units:
 - One for the CPU
 - One for the high-speed I/O modules
 - One for other modules (internal I/O Bus).

Conformity to standards

| Type | Performance |
|--------------------------------|---|
| Surge immunity 24 VDC circuit | EN/IEC 61000-4-5 1 kV in common mode 0.5 kV in differential mode |
| Surge immunity 230 VAC circuit | EN/IEC 61000-4-5 2 kV in common mode 1 kV in differential mode |
| Induced electromagnetic field | EN/IEC 61000-4-6 10 Veff (0.15...80 MHz) |
| Conducted emission | EN 55011 (IEC/CISPR11) 150...500 kHz, quasi peak 79 dB μ V 500 kHz...30 MHz, quasi peak 73 dB μ V |
| Radiated emission | EN 55011 (IEC/CISPR11) 30...230 MHz, 10 m @ 40 dB μ V/m 230 MHz...1 GHz, 10 m @ 47 dB μ V/m |

Assembly and mounting

The components of this system have been designed for simple interlocking mechanical assembly. An 8-way expansion bus connection (2 for the power supply, 2 for the bus and 4 for the data) is used to distribute data and the power supply when assembling the components: the LMC058 motion controller with compact blocks and modules (Digital, analog, Expert, Common Distribution, Power Distribution, bus expansion). Each element which make up the system is mounted on a symmetrical rail using the locking levers located on top of the device.

Wiring and maintenance of devices is simplified by the use of removable spring terminals. The spring terminals are undone by pressing a locking tab.

The system is integrated into communication networks: the connectors (RJ45, USB, mini-USB and SUB-D type) are accessible, as they are located on the motion controller front panels.

Local or remote architecture

Local I/O

A PLC configuration can be local or remote. It consists of an LMC058 motion controller with its embedded input and output channels, used in conjunction with compact blocks and/or expansion modules which are used to increase the number of channels and/or application-specific functions.

- Compact blocks represent a way of adding a large number of I/O with a single component, and thus only a single product reference.
- I/O modules (combination of a bus base, an electronic module and a terminal block) complete this configuration and, being modular with between 2 and 12 channels, make it possible to adjust the number of channels to exactly that required. The addition of digital or analog modules, temperature or high-speed counter modules increases the processing capabilities of applications.

Local I/O configuration

- 1 XBTGT supervisory graphic touch screen terminal
- 2 LMC058 motion controller
- 3 Compact blocks or I/O modules

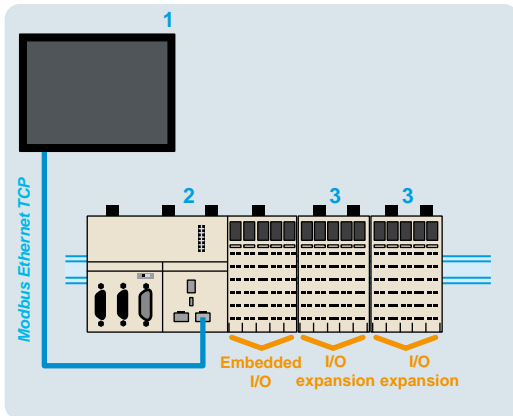

Local I/O

Remote I/O

Because of its backplane bus management, the TM5 system can be used to control I/O remotely.

The same modules can be used in either a local and/or remote configuration, linked together with bus expansion cables.

The maximum distance between two remote islands is 100 m and the maximum number of islands is 25, i.e. a total distance of up to 2500 m.

This function ensures a high level of flexibility, while retaining **synchronization of data acquisition**, since the expansion modules are on the same backplane bus.

Remote I/O configuration

- 1 XBTGT supervisory graphic touch screen terminal
- 2 LMC058 motion controller
- 3 Compact blocks or I/O modules
- 4 Transmitter modules
- 5 Receiver modules
- 6 TM5 expansion bus cables
- 7 Common distribution modules

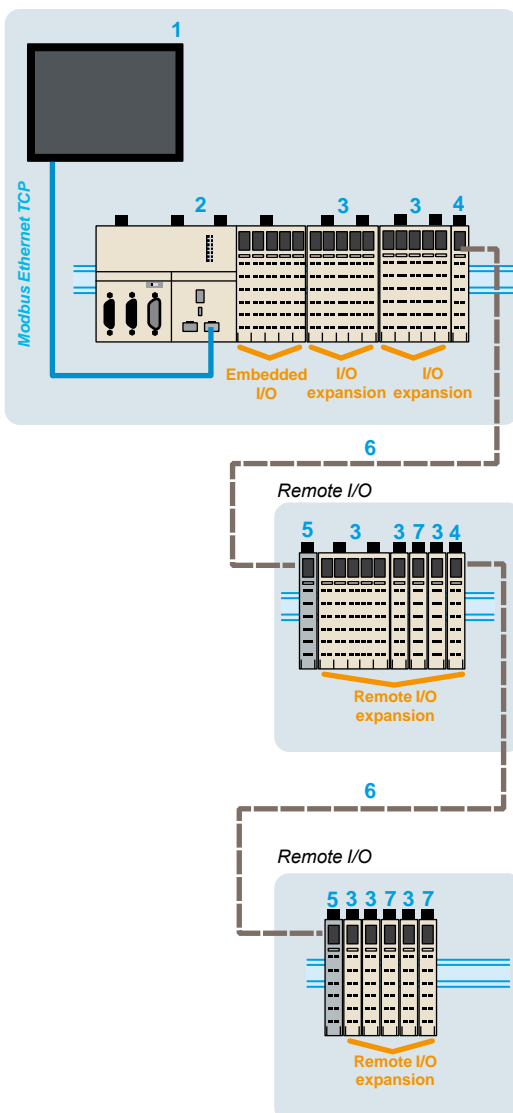

Communication

LMC058 motion controllers have the following built-in communication ports:

| References | Communication ports | Use |
|--------------------|--|--|
| LMC058LF42 | RJ45 Configurable as RS232 or RS485 | ASCII or RTU exchange with Modbus communication protocol |
| | 1 x RJ45 (MDI/MDIX port) | <input type="checkbox"/> FTP server <input type="checkbox"/> Web server <input type="checkbox"/> Modbus TCP server <input type="checkbox"/> Modbus TCP client <input type="checkbox"/> SoMachine Manager <input type="checkbox"/> SNMP <input type="checkbox"/> Ethernet IP device <input type="checkbox"/> Modbus device |
| | 1 x USB-A | Connection of a USB memory stick for transferring (uploading/downloading) programs, data and/or firmware |
| | 1 x mini-USB | Programming port (480 Mbps) |
| | 1 x 9-way male SUB-D | CANopen master connection |
| | 1 x 9-way male SUB-D | CANmotion master connection |
| | 1 x 15-way female SUB-D | Master encoder |
| LMC058LF424 | RJ45 Configurable as RS232 or RS485 | ASCII or RTU exchange with Modbus communication protocol |
| | 1 x RJ45 (MDI/MDIX port) | <input type="checkbox"/> FTP server <input type="checkbox"/> Web server <input type="checkbox"/> Modbus TCP server <input type="checkbox"/> Modbus TCP client <input type="checkbox"/> SoMachine Manager <input type="checkbox"/> SNMP <input type="checkbox"/> Ethernet IP device <input type="checkbox"/> Modbus device |
| | 1 x USB-A | Connection of a USB memory stick for transferring (uploading/downloading) programs, data and/or firmware |
| | 1 x mini-USB | Programming port (480 Mbps) |
| | 1 x 9-way male SUB-D | CANopen master connection |
| | 1 x 9-way male SUB-D | CANmotion master connection |
| | 1 x 15-way female SUB-D | Master encoder |
| | 2 PCI slots for communication modules = 2 x 9-way male SUB-D | Addition of optional communication modules for a serial link and a connection on the bus Profibus DP |

Embedded Ethernet

LMC058 motion controllers have an embedded Ethernet link via a direct connection to their RJ45 port.

- Speed: "10 BaseT" and "100 BaseTX" with auto-negotiation
- RJ45 port (MDI/MDIX): automatic adaptation to a straight or crossed cable

| References | Protocols | Number of connections |
|--------------------|--------------------|-----------------------|
| LMC058LF42 | Modbus server | 8 |
| LMC058LF424 | Modbus device | 2 |
| | SoMachine | 3 (1) |
| | Ethernet IP device | 16 |
| | FTP server | 4 |
| | Web server | 10 |

(1) The Oscilloscope function uses one connection.

Nota: Communication for Modicon LMC058, see chapter 4.

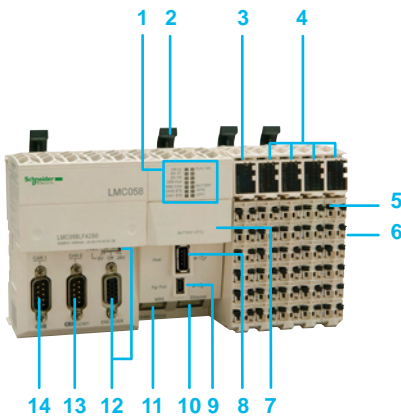

Description

The LMC058LF42 motion controller comprises:

- 1 A display block with:
 - 4 motion controller status LEDs (RUN/MS, BATTERY, APP0 and APP1)
 - 7 built-in communication port status LEDs (*Eth* LA, *Eth* ST, *Eth* NS, USB Host, MBS COM, CAN 0 STS, CAN 1 STS)
- 2 Locking lever for mounting/dismounting on \perp symmetrical rail
- 3 A 24 V $\overline{\text{DC}}$ power supply module with removable terminal block and locking lever, display block and slot for a label
- 4 I/O modules, each one with a removable terminal block with locking lever, a display block showing the I/O states and a slot for a label-holder
- 5 Removable terminal block with locking lever for locking/unlocking
- 6 On the side, an expansion bus connector for connecting to the next module
- 7 A slot for the RTC (Real Time Clock) battery
- 8 A USB-A connector (marked Host) for connecting a USB memory stick for transferring programs, data or firmware updates
- 9 A USB-B mini-connector (marked Pgr Port) for connecting to the programming PC
- 10 An RJ45 connector (marked Ethernet) for connecting to the Ethernet network and/or Magelis XBTGT graphic terminal
- 11 An RJ45 connector (marked MBS) for the RS232 or RS485 serial link
- 12 A 15-way female SUB-D connector, marked ENCODER, for connecting the master encoder and a selector switch for the 3 encoder supply voltage states (5 V, Off, 24 V)
- 13 A 9-way male SUB-D connector, marked CAN0, for connecting to the CANopen bus
- 14 A 9-way male SUB-D connector, marked CAN1, for connecting to the CANmotion bus

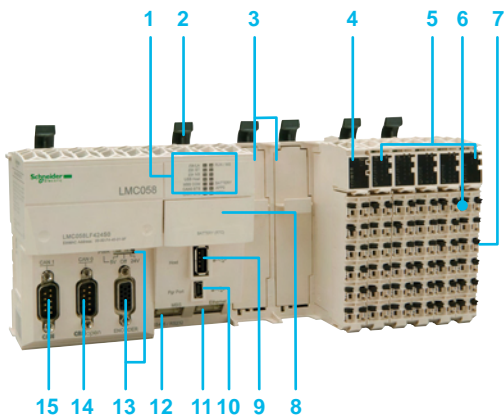

The LMC058LF424 motion controller comprises:

- 1 A display block with:
 - 4 motion controller status LEDs (RUN/MS, BATTERY, APP0 and APP1)
 - 7 built-in communication port status LEDs (*Eth* LA, *Eth* ST, *Eth* NS, USB Host, MBS COM, CAN 0 STS, CAN 1 STS)
- 2 Locking lever for mounting/dismounting on \perp symmetrical rail
- 3 Two free PCI slots for the communication modules
- 4 A 24 V $\overline{\text{DC}}$ power supply module with removable terminal block and locking lever, display block and slot for a label
- 5 I/O modules, each one with a removable terminal block with locking lever, a display block showing the I/O states and a slot for a label-holder
- 6 Removable terminal block with locking lever for locking/unlocking
- 7 On the side, an expansion bus connection for the link with the next module
- 8 A slot for the RTC (Real Time Clock) battery
- 9 A USB-A connector (marked Host) for connecting a USB memory stick for transferring programs, data or firmware updates
- 10 A USB-B mini-connector (marked Pgr Port) for connecting to the programming PC
- 11 An RJ45 connector (marked Ethernet) for connecting to the Ethernet network and/or Magelis XBTGT graphic terminal
- 12 An RJ45 connector (marked MBS) for the RS232 or RS485 serial link
- 13 A 15-way female SUB-D connector, marked ENCODER, for connecting the master encoder and a selector switch for the 3 encoder supply voltage states (5 V, Off, 24 V)
- 14 A 9-way male SUB-D connector, marked CAN0, for connecting to the CANopen bus
- 15 A 9-way male SUB-D connector, marked CAN1, for connecting to the CANmotion bus



LMC058LF42



LMC058LF424

References

LMC058 motion controllers, 24 V $\overline{\text{---}}$ power supply (1)

| No. of I/O | Inputs | Outputs | Built-in communication ports | Reference | Weight kg/ lb |
|------------|--|--|--|--------------------|---------------------|
| 42 I/O | <ul style="list-style-type: none"> ■ 26 x 24 V $\overline{\text{---}}$ digital inputs including 8 counter inputs (200 kHz) | <ul style="list-style-type: none"> ■ 16 digital transistor outputs (0.5 A) including 4 reflex outputs | <ul style="list-style-type: none"> □ 1 RJ45 port: Ethernet □ 1 SUB-D port (9-way male): CANopen master □ 1 SUB-D port (9-way male): CANmotion master □ 1 SUB-D port (15-way female): master encoder □ 1 USB-A port: program transfer □ 1 USB-B mini-port: software programming □ 1 RJ45 port: RS232/RS485 serial link | LMC058LF42 | 0.550/ 1.213 |
| 42 + 4 I/O | <ul style="list-style-type: none"> ■ 26 x 24 V $\overline{\text{---}}$ digital inputs including 8 counter inputs (200 kHz) ■ 4 analog inputs 10 V/- 10 V, 4-20 mA/ 0-20 mA, 12-bit resolution | <ul style="list-style-type: none"> ■ 16 digital transistor outputs (0.5 A) including 4 reflex outputs | <ul style="list-style-type: none"> □ 1 RJ45 port: Ethernet □ 1 SUB-D port (9-way male): CANopen master □ 1 SUB-D port (9-way male): CANmotion master □ 1 SUB-D port (15-way female): master encoder □ 1 USB-A port: program transfer □ 1 USB-B mini-port: software programming □ 1 RJ45 port: RS232/RS485 serial link <p>□ + 2 free PCI slots for optional communication modules (2): RS232/RS485 serial link and Profibus DP bus</p> | LMC058LF424 | 0.770/ 1.698 |

(1) The motion controllers Modicon LMC058 require a power supply with a nominal voltage of 24 V $\overline{\text{---}}$. The 24 V $\overline{\text{---}}$ power supply must be rated Separated Extra Low Voltage (SELV-rated) according to IEC 61140. The SELV-rating means that SELV isolation is provided between the electrical input and output of the power supply.
 (2) To be ordered separately, see page 4/10.



TM5ACTLC100



TM5ACTCH100

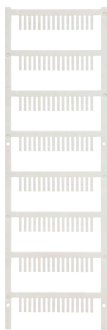

TM5ACLITW1



TM5ACTL1

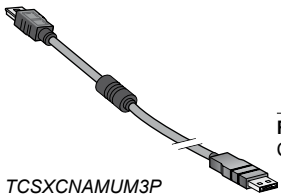

TCSXCNAMUM3P

| References | | | | | | |
|--|--|--|-----------------|----------------|--------------|--|
| Accessories | | | | | | |
| Designation | Used for | Colour | Sold in lots of | Unit reference | Weight kg/lb | |
| Plain text cover holder (label-holder) | Labelling the terminal blocks on the I/O channels | Transparent | 100 | TM5ACTCH100 | 0.002/0.004 | |
| Terminal block shield locking clip (Order with plain text cover holder TM5ACTCH100) | Locking plain text cover holder TM5ACTCH100 | Transparent | 100 | TM5ACTLC100 | 0.001/0.002 | |
| Sheet of 92 precut paper labels | Plain text cover holder TM5ACTCH100 | White | 100 | TM5ACTLS100 | 0.001/0.002 | |
| Coloured plastic markers | Labelling 16 connection channel terminals | White | 1 | TM5ACLITW1 | 0.015/0.033 | |
| | | Red | 1 | TM5ACLITR1 | 0.015/0.033 | |
| | | Blue | 1 | TM5ACLITB1 | 0.015/0.033 | |
| Metal tool | Inserting/removing TM5ACLIT ¹ markers | Black | 1 | TM5ACTL1 | 0.030/0.066 | |
| Connection cables | | | | | | |
| Designation | Used from | to | Length m/ft | Reference | Weight kg/lb | |
| Software programming cable Baud rate: 480 Mbps max. Protocol: Modbus, HTTP, FTP, Codesys or virtual, non-isolated | PC USB port | USB mini-port on LMC058 motion controllers, the ATV-IMC card or XBTGT graphic touch screen terminals | 3/9.84 | TCSXCNAMUM3P | 0.065/0.143 | |
| RS485 serial link cables Modbus protocol | SUB-D port (25-way) on Small Panels: XBTN401, XBTN410, XBTR410, XBTR411, XBTGT2... GT7 | RJ45 port on LMC058 motion controllers | 1.8/5.90 | XBTZ938 | 0.230/0.507 | |
| | RJ45 port on XBTGT graphic touch screen terminals | RJ45 port on LMC058 motion controllers | 2.5/8.20 | XBTZ9980 | 0.230/0.507 | |
| RS232 serial link cables Character mode | SUB-D port (9-way female) on DTE (1): printer, hand-held bar code reader, etc. | RJ45 port on LMC058 motion controllers | 3/9.84 | TCSMCN3M4F3C2 | 0.150/0.331 | |
| | SUB-D port (9-way female) on DCE (2): GSM modem | RJ45 port on LMC058 motion controllers | 3/9.84 | TCSMCN3M4M3S2 | 0.150/0.331 | |
| Cable for master encoder input | Incremental encoders or SSI serial absolute encoders (1 stripped end) | 15-way female SUB-D port on LMC058 motion controllers (1 High Density 15-way male SUB-D connector) | 1/3.28 | VW3M4701 | - | |

(1) DTE: Data Terminal Equipment

(2) DCE: Data Communication Equipment

Presentation

Modicon LMC078 motion controllers are designed for compact machines that require a high level of performance in motion control applications as well as control system and machine communication function management.

Their high processing power enables:

- Control of 8 synchronized axes in 1 ms/16 synchronized axes in 2 ms
- Execution of a Boolean instruction in 2 ns
- A minimum cycle time of 250 μs

Control functions

Modicon LMC078 motion controllers integrate the following standard motion control functions:

- > Velocity control and torque control
- > Relative or absolute positioning
- > Cam profiles for slave axes and programmable cam switch control
- > Virtual axes
- > Electronic gearing function for position control
- > Linear and circular interpolations via the G-code function
- > Master and virtual axes via external encoder

Applications

Modicon LMC078 motion controllers, combined with a dedicated Lexium 32S offer, provide a simple yet powerful solution for the following applications:

- > Machines performing operations “on the fly”: marking, adhesion, shearing, etc.
- > Packing machines (vertical and horizontal bagging): forming, filling, and sealing, etc.
- > Handling machines: packaging, sorting, palletizing, etc.

Hardware characteristics

- Modicon LMC078 motion controllers are in “book” format; dimensions (DxWxH) 220 x 45 x 230 mm.
- Modicon LMC078 motion controllers have:
 - 12 inputs, 8 outputs (the I/O embedded in the controller are connected via removable spring terminals (1))
 - an encoder input configurable as an incremental or a Sin/Cos absolute encoder
- The 24 V $\overline{\text{DC}}$ controller power is supplied by an external source connected via removable spring terminals (1).
- The controller has a slot for an SD (Secure Digital) card (supplied with the controller).
- The Modicon LMC078 controller has a QR code for direct access to technical documentation relating to the controller and its associated servo drive.

Embedded communication

Modicon LMC078 motion controllers integrate the following embedded communication features as standard:

- sercos III communication bus
 - real-time communication bus (100 Mbps) for position control and remote I/O management
 - RJ 45 connectors
 - topology types: Master/Slave, linear or ring (for enhanced availability)
- CANopen bus
 - for controlling slave devices (63 slaves)
 - 9-way SUB-D connector
- Ethernet
 - communication network with supervisory tools
 - RJ 45 connector
 - Ethernet TCP/IP, FTP, and Ethernet Modbus TCP protocols
- Serial link
 - RS232 or RS485 configurable
 - RJ 45 connector
 - Modbus ASCII/RTU Master/Slave, ASCII (character string) protocols

(1) Connection terminals supplied with the controller





SoMachine software platform

Software configuration

Using SoMachine V4.1 software to configure and program Modicon LMC078 motion controllers and associated devices designed in line with Schneider Electric's Flexible Machine Control concept helps to reduce costs and optimize machine performance.

SoMachine V4.1 integrates tested, validated, documented architectures (TVDA), templates and dedicated motion control libraries.

The "Motion Library" contains a selection of function blocks designed to help reduce device configuration times.

This PLCopen-compliant library consists of administrative function blocks (read/write parameters, states, etc.) and single-axis and multi-axis function blocks.

The main functions are as follows:

- Power on, stop, reset
- Relative, absolute, or additional positioning
- Continuous positioning (reaching a position at a predefined speed)
- Velocity control
- Velocity profile
- Position profile
- Cam profile
- Electronic gearing
- Phasing
- Programmable cam switch
- Linear or circular interpolation

User library

With SoMachine software, it is easy to create your own function blocks (user library) to reduce programming times. Creating a user library simplifies the standardization and reuse of programs and also allows you to help protect proprietary information.

Note: Applications created with a Modicon LMC058 controller (as well as applications created with earlier versions of SoMachine) can be reused on the LMC078 motion controller.

Embedded functions on the LMC078 motion controller

- > PID control, with SoMachine library
- > SoftMotion libraries integrating coordinated motion functions, and synchronized axis management through gearing, camming, and path follower functions (G-code). An integrated path editor provides simplified access to G-code programming.
- > Diagnostics tools:
 - with message log, error message, and time-stamping
 - integrated diagnostics on controller display
 - integrated oscilloscope function in SoMachine software
- > I/O expansion with Modicon TM5 and TM7 ranges of expansion modules:
 - Modicon TM5 (IP 20) for expansion of digital, analog, and expert (counter module) I/O (see page 3/38)
 - Modicon TM7 (IP 67) for expansion of digital and analog I/O (see page 3/64)

2

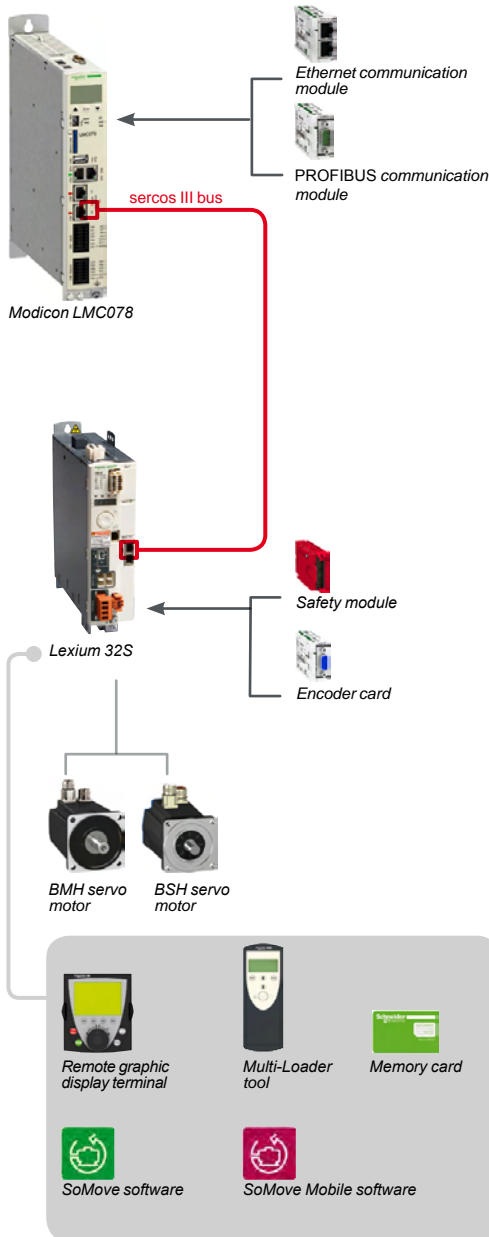

Options and software for LXM32S servo drives

Options for Modicon LMC078 motion controllers

Communication modules

LMC078 motion controllers have a slot for an additional communication module.

Two types of communication module are available:

- VW3E704100000 EtherNet/IP slave interface
- VW3E704000000 PROFIBUS DP slave interface

Expansion memory

LMC078 motion controller memory can be expanded using a USB flash drive: stored files can be read/written via function blocks managed by the application.

Offer associated with the LMC078 controller

Lexium 32S servo drives are used with Modicon **LMC078** motion controllers to facilitate configuration and startup.

Performance is enhanced through optimized motor control achieved through reduced vibration with automatic parameter calculation, a speed observer, and an additional band-stop filter. This optimization helps to increase machine productivity.

Modicon LMC078 motion controllers are programmed using SoMachine software; the servo drive is set up using SoMove software.

The compact size of Lexium 32S servo drives and the associated BSH and BMH servo motors offers optimum performance in a small area, thus helping to reduce the overall size and cost of equipment.

Lexium 32S servo drives offer the following options:

- Memory card (SIM type) for saving the servo drive parameters (**recommended to help ensure a quick resumption of operation after a drive is replaced**)
- Enhanced safety module for integrated safety functions in a control system
- A module for handling a second encoder input

I/O expansion

Modicon LMC078 motion controllers can expand the I/O configuration over the sercos III and/or the CANopen bus.

- Over sercos III bus
 - The **TM5NS31** interface module for sercos III bus allows connection of distributed I/O islands (sensors and actuators) that are distributed over machines via the sercos III bus.

[Modicon TM5NS31 interface for sercos III bus \(please refer to our website www.schneider-electric.com\)](http://www.schneider-electric.com)

- Over CANopen bus
 - The **TM5NCO1** CANopen interface module allows the connection of distributed I/O islands (sensors and actuators) that are distributed over machines via the CANopen fieldbus.

[Modicon TM5NCO1 interface for CANopen bus \(please refer to our website www.schneider-electric.com\)](http://www.schneider-electric.com)

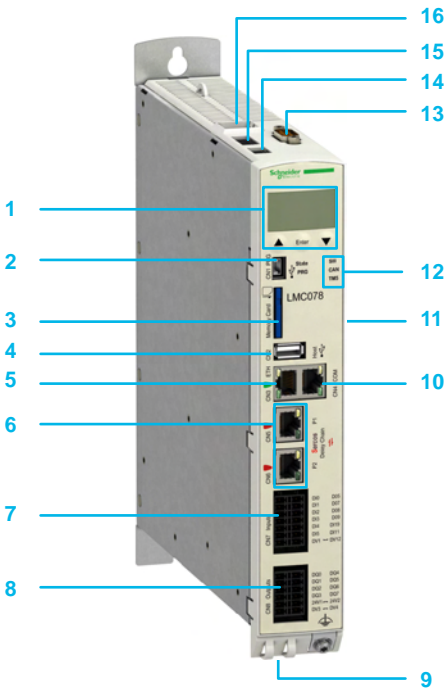

Description

Modicon LMC078 motion controller

- 1 LCD display and control keys
- 2 Mini USB programming connector
- 3 SD card slot (for firmware and project data)
- 4 USB-A connector for memory expansion
- 5 RJ 45 connector for Ethernet network, with status LED
- 6 Two RJ 45 connectors for sercos III network
- 7 Removable spring terminals (1) for connecting 12 digital inputs (8 standard inputs + 4 Registration inputs)
- 8 Removable spring terminals (1) for connecting 8 digital outputs
- 9 Slot for 1 communication module (EtherNet/IP or Profibus DP bus)
- 10 RJ 45 connector for serial link, with status LED
- 11 (On the side panel) QR code for identifying LMC078 and LXM32S technical documentation
- 12 Controller status LED display block
- 13 9-way SUB-D connector for CANopen bus connection
- 14 Removable spring terminals (1): 3 terminals: +, -, \perp marked 24 VDC for connecting the 24 V $\overline{\text{DC}}$ power supply
- 15 Not used
- 16 RJ 45 connector for Master encoder (incremental or absolute encoder)

(1) Removable spring terminals supplied with the controller

| LMC078 motion controller characteristics | |
|---|---|
| Conformity | |
| Certification | CE, UL, CSA 508 |
| Standards | IEC61131-2 |
| Operating characteristics | |
| Class 3 K3 conforming to IEC/EN 60721-3-3 | |
| Degree of protection | IP 20 |
| Pollution degree | 2 (conforming to IEC-61131-2, UL508) |
| Ambient temperature | +5 ... + 55 °C/41...131 °F |
| Condensation or refrigeration | Not tolerated |
| Relative humidity | 5...95% |
| Operating altitude | 0...2,000 m without derating 2,000...3,000 m: ambient temperature 40 °C/104 °F |
| Class 3M4 | |
| Shock resistance | 100 m/s ² |
| Vibration resistance | 10 m/s ² |
| Transportation characteristics | |
| Class 2K3 conforming to IEC/EN 60721-3-2 | |
| Ambient temperature | -25... +70 °C /-13...+158 °F |
| Condensation or refrigeration | Not tolerated |
| Relative humidity | 5...95% |
| Maximum operating altitude | 10,000 m (32,808 ft) |
| Class 2M2 | |
| Shock resistance | 300 m/s ² |
| Vibration resistance | 15 m/s ² |
| Characteristics of long-term storage in original packaging | |
| Class 1K4 conforming to IEC/EN 60721-3-1 | |
| Ambient temperature | -25... + 55 °C/-13...+131 °F |
| Condensation or refrigeration | Not tolerated |
| Relative humidity | 5... 95% |
| Power supply characteristics | |
| Power supply | 24 V \pm (20.4 to 30 V \pm), 30 W max. |



LMC078CECS20T



VW3E704100000



VW3E704000000

References

Modicon LMC078 motion controller (1)

24 V $\bar{\bar{}}$ power supply

| Number of logic I/O | Logic inputs | Logic outputs | Embedded communication ports (2) | | | Reference | Weight kg/lb | |
|---|---|-----------------------------------|----------------------------------|-----------------|-----------|-----------|-----------------|-----------------|
| | | | sercos III | CANopen master | Ethernet | | | Serial link |
| 20 I/O and 1 encoder input | 12 x 24 V $\bar{\bar{}}$ source inputs, including 4 registration inputs | 8 source transistor outputs 0.5 A | 2 x RJ 45 | 1 x 9-way SUB-D | 1 x RJ 45 | 1 x RJ 45 | LMC078CECS20T | 2.200/ 4.850 |
| 1 configurable encoder input: <ul style="list-style-type: none"> <input type="checkbox"/> incremental encoder, output voltage 5 V $\bar{\bar{}}$ /200 mA <input type="checkbox"/> absolute encoder (Sin Cos/Hiperface), output voltage 10 V $\bar{\bar{}}$ /200 mA Connection via RJ 45 connector | | | | | | | | |
| SD card | Blank SD card | | | | | TMASD2 | 0.004/ 0.009 | |

Options for Modicon LMC078 controller

| Designation | Description | Reference | Weight kg/lb |
|----------------------|---|---------------|--------------|
| Communication module | Ethernet/IP slave module equipped with 2 RJ 45 connectors with status LED | VW3E704100000 | – |
| | PROFIBUS DP slave module equipped with a 9-way SUB-D connector | VW3E704000000 | – |

Cordsets

| Designation | Description | Length m/ft | Reference | Weight kg/lb |
|--|---|-------------|--------------|--------------|
| sercos III cordsets for redundant ring | Preassembled cordsets with an RJ 45 connector at each end | 0.5/1.64 | VW3E5001R005 | – |
| | | 1/3.28 | VW3E5001R010 | – |
| | | 1.5/4.92 | VW3E5001R015 | – |
| | | 2/6.56 | VW3E5001R020 | – |
| | | 3/9.84 | VW3E5001R030 | – |
| | | 5/16.40 | VW3E5001R050 | – |
| | | 10/32.81 | VW3E5001R100 | – |
| | | 15/49.21 | VW3E5001R150 | – |
| | | 20/65.62 | VW3E5001R200 | – |
| | | 25/82.02 | VW3E5001R250 | – |
| 30/98.43 | VW3E5001R300 | – | | |
| 40/131.23 | VW3E5001R400 | – | | |
| 50/164.04 | VW3E5001R500 | – | | |

Configuration software

| Description | Use | See page |
|--------------------------|--|----------|
| SoMachine V4.1 + 1 addon | For configuring Modicon LMC078 controllers | 5/2 |

Associated offers

| | |
|---|--|
| Modicon TM5 digital/analog/expert I/O expansion modules | 3/38 |
| Modicon TM7 digital/analog I/O expansion modules | 3/64 |
| Modicon TM5 bus interface module for sercos III | Please refer to our website www.schneider-electric.com |
| Modicon TM5 bus interface module for CANopen | 4/28 |
| Modicon TM5 communication module for RS232 serial link | Please refer to our website www.schneider-electric.com |

(1) LMC078 controllers include:

- removable terminals (spring terminals) for connecting I/O
- removable spring terminals for connecting the power supply
- BR2032 button cell battery
- an SD card with the controller firmware.

(2) LMC078 controllers have an embedded USB mini-B programming port.

Hardware control platforms

Drive controller

Altivar IMC integrated controller card for Altivar 61 and Altivar 71 variable speed drives

2



Altivar IMC integrated controller card

Presentation

The Altivar IMC integrated controller card forms a part of Flexible Machine Control approach, a key component of MachineStruxure™, which brings you maximum flexibility and ensures the most optimised control solution. The Altivar IMC integrated controller card **VW3A3521** is a compact optimised solution developed for Altivar 61 and 71 variable speed drives. When equipped with the ATV IMC card, Altivar 61 and 71 drives become controllers capable of meeting the needs of machine manufacturers (OEMs) in applications such as textiles, hoisting, pumping or woodworking, etc.

The Altivar IMC integrated controller card **VW3A3521** is configured and programmed using SoMachine software (see page 5/2).

The expansion capability of the Altivar IMC card is based on Schneider Electric's "Flexible Machine Control" concept.

The Altivar IMC card boosts the expansion capability of machines and allows us to meet the OEM market's requirements in terms of performance, simplicity of use and openness.

Installation

The Altivar IMC card is designed for integration on Altivar 61 and 71 variable speed drives in conjunction with other Altivar 61 and 71-specific cards, such as I/O expansion cards and communication cards.

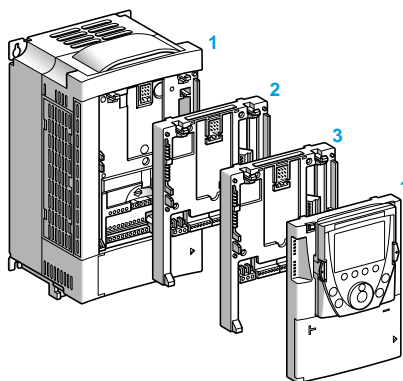

- 1 Altivar 61/Altivar 71 drive and graphic display terminal
- 2 Altivar IMC card **VW3A3521**
- 3 I/O expansion card **VW3A32●●** or communication card **VW3A33●●**

Note: Only one I/O expansion card or communication card can be mounted simultaneously with the Altivar IMC card on an Altivar 61 or 71 drive.

Special features

| | | |
|---|------------------------------|---|
| User memory | RAM | 2 MB |
| | Flash | 2 MB |
| Data storage memory FRAM (Ferroelectric RAM) | | 64 KB |
| Typical time (for 1000 Boolean instructions) | | 942 μs |
| User program size | | 1 MB |
| Power supply | | 24 V $\overline{\text{DC}}$ |
| Inputs | Digital | 10 x 24 V $\overline{\text{DC}}$ inputs, 4 of which can be used for 2 high-speed counter inputs (100 kHz) or 2 incremental encoders (A/B) (100 kHz) |
| | Analog | 2 x 0...20 mA inputs |
| Outputs | Digital | 6 transistor outputs (2 A) - source |
| | Analog | 2 x 0...20 mA outputs |
| Built-in communication ports | RJ45 port | Ethernet Modbus TCP, Web/FTP Server |
| | SUB-D connector (male 9-way) | Master CANopen bus (16 slaves) |
| | USB Mini-B port | SoMachine software programming |
| Real-time clock | | Integrated |

Hardware control platforms

Drive controller

Altivar IMC integrated controller card for Altivar 61 and Altivar 71 variable speed drives

Performance

Reduce the time it takes to develop your machines

- The use of a single SoMachine programming software environment offers a number of advantages:
 - A single project file
 - A single software program
 - A single download for the whole application
- The ease of use of PLCopen function blocks significantly reduces the time needed to program motion control and independent axis control on machines.

A more powerful machine

The Altivar IMC integrated controller card has 8 tasks to suit different machine requirements (cyclic, event-triggered, free).

A task can be synchronized with the task of the drive in which it is embedded. This task manages the speed reference, the torque reference, the speed feedback, the torque feedback, the number of encoder pulses feedback in order to increase machine performance.

A more intelligent drive

- Performs more complex operations (2 MB memory)
- Reduces program loading time (Mini-B USB connectors)
- Communication with all the other system devices (built-in Ethernet and CANopen connection ports)

Transparency of your machines

Access to all the other devices in the system architecture via CANopen is totally transparent due to FDT/DTM technology.

Development and technology

The Altivar IMC integrated controller card has been developed with two criteria in mind: low cost and practicality.

■ Low cost because the standard equipment for the Altivar IMC card comprises:

- Sixteen discrete I/O
- A built-in Ethernet port
- Two analog inputs
- Two analog outputs
- And a CANopen master

■ Practicality because the Altivar IMC card is ideal for integration in Altivar 61 and 71 drives, and can therefore use:

- Their inputs/outputs
- Their communication cards
- Their parameters: speed, current, torque, etc.
- Their remote graphic display terminal
- And also the inputs/outputs in their I/O expansion cards
- Plus the speed feedback counter in the encoder interface cards

Software configuration

Configuration and programming of the Altivar IMC integrated controller card and equipment in Schneider Electric's "Flexible Machine Control" concept are both designed to cut costs and optimize your machine performance.

Schneider Electric's **SoMachine** software platform can be used to program Altivar IMC integrated controller card using:

- IEC 61131-3 programming languages: Instruction List (IL), Ladder Diagram (LD), Function Block Diagram (FBD), Sequential Function Chart/Grafset (SFC) and Structured Text (ST)
- CFC (Continuous Function Chart) language.

PLCopen function blocks are used for managing motion control and axis control on your machines.

See page 5/2.

Integration in the Schneider Electric product offer

Combined with other dedicated OEM products in the Schneider Electric offer, such as Altivar variable speed drives, Lexium servo drives, Magelis HMI terminals, TeSys motor starters and contactors, the Altivar IMC integrated controller card can be integrated transparently in a number of architectures.



SoMachine software platform

Hardware control platforms

Drive controller

Altivar IMC integrated controller card for Altivar 61 and Altivar 71 variable speed drives

2

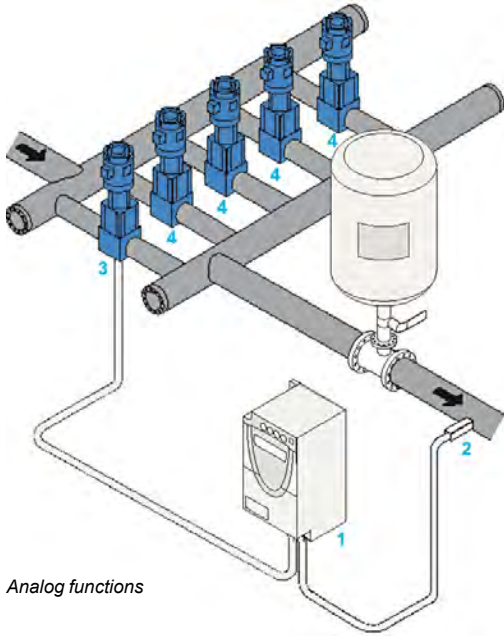

Analog functions

Functions

Analog functions

For machines that require functions to process data issued by analog sensors/actuators (voltage or current), temperature sensors, pressure or PID control sensors, the Altivar IMC card has, as standard, 2 analog inputs (voltage or current) with 10-bit resolution and 2 analog outputs (current) with 10-bit resolution.

- 1 Altivar IMC integrated controller card installed on Altivar 61
- 2 Pressure sensor
- 3 Variable speed pump
- 4 Fixed speed pumps

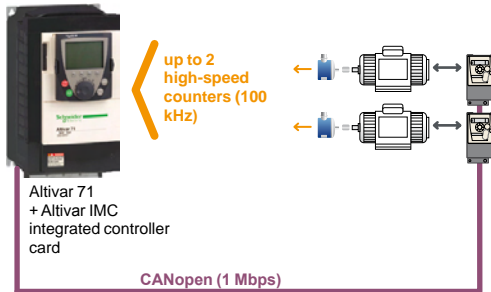

High-speed counter function (one-phase or two-phase)

HSC high-speed counting and/or incremental encoder function

In order to meet requirements for machine productivity, the Altivar IMC has 2 embedded high-speed counters with a counting frequency of 100 kHz for each channel as well as 4 reflex outputs.

The availability of these embedded counters and also the presence of the master CANopen link makes it quick and easy to create low-cost, high-performance multi-axis functions that suit the machines limitations.

With the availability of "PLCopen" function blocks specific to the motion control functions in the SoMachine software, application development is sure to be quick and reliable.

In addition, these high-speed counting inputs can be used as an incremental encoder (A/B) with a frequency of 100 kHz in order to adapt to the machine's specific requirements.

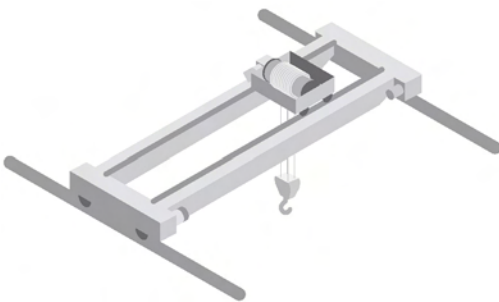

Machine with CANopen architecture:

- Lifting motion: Altivar 71
- Translatory motion: Altivar 312
- Carriage motion: Altivar 312

Position control function

Several options are offered in terms of position control:

- Either creating a sequence in Lexium 32 servo drives, with communication with the Altivar IMC integrated controller card achieved by the use of discrete I/O
- Or creating an application in the Altivar IMC card and controlling the Lexium 32A/ Lexium 32M servo drives and/or SD3●● stepper motor drives via the master CANopen integrated link.

Functions (continued)

Communication function

Ethernet

The Altivar IMC integrated controller card has a built-in RJ45 Ethernet port (10/100 Mbps, MDI/MDIX) with Ethernet TCP Modbus, SoMachine on Ethernet, UDP, TCP and SNMP protocols.

In addition, the Altivar IMC card has an embedded Web Server and FTP Server. As well as the default address based on the MAC address, it is possible to assign a controller IP address via a DHCP server or via a BOOTP server.

CANopen

The Altivar IMC integrated controller card has an embedded CANopen master which can be used to control devices on a communication bus with ease.

The link can be configured between 20 kbps and 1 Mbps and supports up to 16 slaves.

Architectures based on CANopen can be used to distribute I/O modules as close to the sensors and actuators as possible, thus reducing wiring costs and times, and to communicate with different devices such as variable speed drives, servo drives, etc. The CANopen configurator is integrated in the SoMachine software and can also be used to import standard description files in EDS format. See page 4/14.

Customization function on the graphic display terminal

Menu 1.14

The remote graphic display terminal on Altivar 61 or 71 drives includes a menu dedicated to the Altivar IMC integrated controller card.

The user is offered a graphic display of 8 lines of 24 characters.

This menu can be customized simply and directly using the SoMachine software.

The user can define the language, name, unit, decimal point, and the type of parameter he wishes to customize for his own application. The user can also define alarms and error messages for his application.



Menu 1.14

Clock function

A time and date-stamping function combined with a clock backed up by a lithium battery makes it possible to keep a log of events that have occurred. When the Altivar IMC integrated controller card is installed in the drive, drive faults are automatically time and date-stamped without the need for any special programming.

Hardware control platforms

Drive controller

Altivar IMC integrated controller card for Altivar 61 and Altivar 71 variable speed drives

Communication

The Altivar IMC integrated controller card has the following built-in communication ports:

| Communication ports | Use |
|--------------------------|---|
| 1 x RJ45 (MDI/MDIX port) | <input type="checkbox"/> FTP server <input type="checkbox"/> Web server <input type="checkbox"/> Modbus TCP server <input type="checkbox"/> Modbus TCP client <input type="checkbox"/> Manager SoMachine <input type="checkbox"/> SNMP <input type="checkbox"/> Modbus device |
| 1 x mini-USB | Programming port (480 Mbps) |
| 1 x 9-way male SUB-D | Master CANopen connection |

Embedded Ethernet

The Altivar IMC integrated controller card has an embedded Ethernet link via a direct connection to its RJ45 port.

- Speed: "10 BaseT" and "100 BaseTX" with auto-negotiation
- RJ45 port (MDI/MDIX): automatic adaptation to a straight or crossed cable

| Protocols | Number of connections |
|---------------|-----------------------|
| Modbus server | 8 |
| Modbus device | 2 |
| FTP server | 4 |
| Web server | 10 |

Description

The Altivar IMC integrated controller card comprises:

- 1 Three spring connectors for:
 - 10 digital inputs
 - 6 digital outputs
 - 2 analog inputs
 - 2 analog outputs
 - 2 commons
- 2 A connector with removable screw terminals, 3 contacts at intervals of 3.81 for the 24 V $\bar{\text{---}}$ power supply
- 3 A mini USB-B connector for programming using SoMachine software
- 4 A 9-way SUB-D connector for connection to the CANopen machine bus
- 5 An RJ45 connector for connection of the SoMachine software workshop and/or connection to an Ethernet Modbus TCP network
- 6 Five LEDs:
 - 1 green/yellow ETH LED for Ethernet activity
 - 1 green/red NS (Network status) LED
 - 1 green/red MS (Module status) LED
 - 1 green/red CAN (CANopen activity) LED
 - 1 green/red LED programmable by the user
- 7 Four configuration selector switches

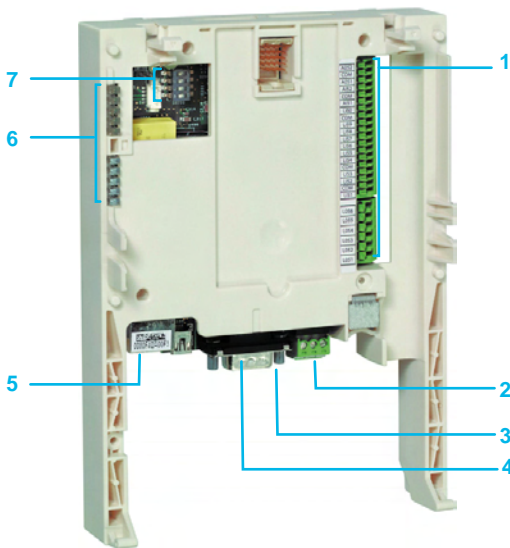



Altivar 71 variable speed drives



VW3A3521



VW3A3202

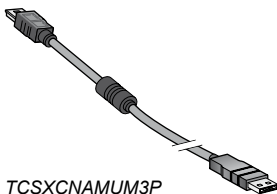

TCSXCNAMUM3P

Variable speed drives

| Designation | Reference |
|----------------------------------|---|
| Altivar 61 variable speed drives | Refer to our website www.schneider-electric.com |
| Altivar 71 variable speed drives | Refer to our website www.schneider-electric.com |

Cards for Altivar 61 and 71 variable speed drives

| Altivar IMC integrated controller card | | | |
|--|-----------------------------|-----------|---------------------|
| Designation | Voltage | Reference | Weight kg/ lb |
| Altivar IMC integrated controller card | 24 V $\overline{\text{DC}}$ | VW3A3521 | 0.185/ 0.408 |

I/O expansion cards (1)

| Designation | Type of I/O | | | | | | Reference | Weight kg/ lb |
|-------------------------|-------------|--------------|--------------|---------------|---------------------|-------------------------|-----------|---------------------|
| | Logic input | Logic output | Analog input | Analog output | PTC probe input (2) | Frequency control input | | |
| I/O expansion cards (2) | 4 | 3 | – | – | 1 | – | VW3A3201 | 0.300/ 0.661 |
| | 4 | 3 | 2 | 2 | 1 | 1 | VW3A3202 | 0.300/ 0.661 |

For more information about digital I/O cards, visit our website www.schneider-electric.com.

Communication cards

| Designation | Protocols available (depending on model) | Reference |
|-------------------------------|--|---|
| VW3A3 3●● communication cards | <input type="checkbox"/> Modbus Plus <input type="checkbox"/> Uni-Telway <input type="checkbox"/> InterBus-S <input type="checkbox"/> Profibus DP <input type="checkbox"/> DeviceNet <input type="checkbox"/> Ethernet Modbus TCP <input type="checkbox"/> Fipio <input type="checkbox"/> EtherNet IP <input type="checkbox"/> CC-Link <input type="checkbox"/> Lonworks (ATV 61) <input type="checkbox"/> METASYS N2 (ATV 61) <input type="checkbox"/> APOGEE FLN (ATV 61) <input type="checkbox"/> BACnet (ATV 61) | Refer to our website www.schneider-electric.com |

Connection cable

| Designation | Use | Length m/ ft | Reference | Weight kg/ lb |
|-------------------|--|--------------------|--------------|---------------------|
| Programming cable | From the mini USB-B port on the Altivar IMC integrated controller card to the type A USB port on the PC terminal for programming and updating firmware | 3/ 9.84 | TCSXCNAMUM3P | 0.065/ 0.143 |

(1) Altivar 61 and 71 variable speed drives can only take one I/O expansion card with the same reference.

(2) This PTC probe input MUST never be used to protect an ATEX motor in applications in explosive atmospheres. Please refer to the ATEX guide which is available on our website "www.schneider-electric.com".





Hardware control platforms

HMI controllers

Magelis™ SCU Small HMI controllers,
Magelis™ XBTGC HMI controllers,
Magelis™ XBTGT, XBTGK Standard Advanced panels + control function

| | | | | |
|-------------------------|---|---|--|---|
| Applications | Display of text messages, graphic objects and mimics, control and configuration of data | | | |
| Terminal type | IEC 1131-2 control function | | | |
| | Small HMI controllers | | For control of simple process | |
| | For control of simple machine | | | |
| |  |  |  |  |
| Display | Type color TFT LCD | | | |
| | Capacity | | | |
| | 3.5" (65 k colors) | 5.7" (65 k colors) | 3.5" (65 k colors) | 5.7" (65 k colors) |
| Data entry | Via touch screen | | | |
| | Static function keys | | | |
| | Dynamic function keys | | | |
| | Service keys | | | |
| | Alphanumeric keys | | | |
| Memory capacity | Application 128 MB Flash EPROM | | | |
| | Expansion - | | | |
| Functions | Maximum number of pages and maximum number of instructions Limited by internal Flash EPROM memory capacity | | | |
| | Variables per page Unlimited (8000 variables max.) | | | |
| | Programmed logic 5 languages according to IEC 1131-2 (LD, ST, FBD, SFC, IL) | | | |
| | Counting/positioning 2 x 100 kHz high speed counter inputs/2 x 50 kHz pulse train outputs | | | |
| | Control (PID) Yes | | | |
| | Representation of variables Alphanumeric, bitmap, bargraph, gauge, tank, tank level indicator, curves, polygon, button, light | | | |
| | Recipes 32 groups of 64 recipes comprising 1024 ingredients max. | | | |
| | Curves Yes, with log | | | |
| | Alarm logs Yes | | | |
| | Real-time clock Built-in | | | |
| I/O | Integrated | | | |
| | <input type="checkbox"/> 14 x 24 V $\overline{\text{V}}$ digital inputs <input type="checkbox"/> 2 high speed counter (HSC) inputs <input type="checkbox"/> 8 digital relay outputs <input type="checkbox"/> 2 pulse train source transistor outputs | | <input type="checkbox"/> 6 x 24 V $\overline{\text{V}}$ digital inputs <input type="checkbox"/> 2 high speed counter (HSC) inputs <input type="checkbox"/> 6 digital relay outputs <input type="checkbox"/> 2 pulse train source transistor outputs <input type="checkbox"/> 2 x 13-bit analog inputs (Voltage/current) <input type="checkbox"/> 2 x 16-bit analogue temperature inputs (TC/PT100-1000) <input type="checkbox"/> 2 x 12-bit analog outputs (Voltage/current) | |
| | I/O modular expansion - | | | |
| Communication | Downloadable protocols Uni-TE, Modbus, Modbus TCP/IP (1) and for PLC brands: Mitsubishi, Omron, Allen-Bradley and Siemens | | | |
| | Asynchronous serial link RS 232C/RS 485 (COM1) | | | |
| | USB ports 1 Host type A + 1 Device type mini-B | | | |
| | Buses and networks 1 CANopen master | | | |
| | Ethernet TCP/IP (10BASE-T/100BASE-TX) | | | |
| | Printer link USB port for parallel printer | | | |
| Design software | SoMachine on Windows XP Professional and Windows 7 Professional 32/64-bit (please refer to our website www.schneider-electric.com) | | | |
| Operating system | Magelis (333 MHz RISC CPU) | | | |
| Terminal type | HMISCU6A5 | HMISCU8A5 | HMISCU6B5 | HMISCU8B5 |
| Pages | 2/85 | | | |

(1) Depending on model.

| | | | | |
|---|---|--|---|---|
| Display of text messages, graphic objects and mimics, control and configuration of data | | | | |
| IEC 1131-2 control function | | | | |
| HMI controllers | | Touch screen Standard Advanced panels + control function | | Standard Advanced panels with keypad + control function |
|  |  |  |  |  |
| Backlit monochrome (amber or red mode) STN LCD (320 x 240 pixels) | Backlit monochrome STN LCD (320 x 240 pixels) | color TFT LCD (320 x 240 pixels) | Backlit monochrome or color STN LCD or color TFT LCD (320 x 240 pixels to 1024 x 708 pixels) (1) | Monochrome STN LCD or color TFT LCD (320 x 240 pixels or 640 x 480 pixels) (1) |
| 3.8" (monochrome) | 5.7" (monochrome) | 5.7" (65 k colors) | 5.7" (monochrome or color) 7.5", 10.4", 12.1" or 15" (color) (1) | 5.7" (monochrome or color) or 10.4" (color) (1) |
| Via touch screen | | | Via keypad and/or touch screen (configurable) and/or by industrial pointer | |
| - | | | 10 or 12 (1) | |
| - | | | 14 or 18 (1) | |
| - | | | 8 | |
| - | | | 12 | |
| 16 MB Flash EPROM | | 16 MB Flash EPROM or 32 MB Flash EPROM (1) | | |
| - | | By 128 MB to 4 GB CF card (1) | | |
| Limited by internal Flash EPROM memory capacity | | | Limited by internal Flash EPROM memory capacity or CF card memory capacity | |
| Unlimited (8000 variables max.) | | | Unlimited (8000 variables max.) | |
| 5 languages according to IEC 1131-2 (LD, ST, FBD, SFC, IL) | | | 5 languages according to IEC 1131-2 (LD, ST, FBD, SFC, IL) | |
| 4 x 100 kHz high speed counter inputs/4 x 65 kHz pulse train outputs | | | - | |
| Yes | | | Yes | |
| Alphanumeric, bitmap, bargraph, gauge, tank, tank level indicator, curves, polygon, button, light | | | Alphanumeric, bitmap, bargraph, gauge, tank, tank level indicator, curves, polygon, button, light | |
| 32 groups of 64 recipes comprising 1024 ingredients max. | | | 32 groups of 64 recipes comprising 1024 ingredients max. | |
| Yes, with log | | | Yes, with log | |
| Yes | | | Yes | |
| Built-in | | | Built-in | |
| <input type="checkbox"/> 12 x 24 V $\overline{\text{V}}$ digital inputs <input type="checkbox"/> 6 sink or source transistor outputs (1) | | <input type="checkbox"/> 16 x 24 V $\overline{\text{V}}$ digital inputs <input type="checkbox"/> 16 sink or source transistor outputs (1) | | - |
| 2 Modicon TM2 I/O modules max. | | 3 Modicon TM2 I/O modules max. | | - |
| - | | Uni-TE, Modbus, Modbus TCP/IP (1) and for PLC brands: Mitsubishi, Omron, Allen-Bradley and Siemens | | |
| - | | RS 232C/RS 422/485 (COM1) | | RS 232C/RS 422/485 (COM1) and RS 485 (COM2) |
| 1 | | 1 | | 1 or 2 (1) |
| 1 CANopen master with optional module (XBTZGC CAN) | | 1 CANopen master with external module (XBTZG CANM) which is mandatory for the control function | | |
| - | | Ethernet TCP/IP (10BASE-T/100BASE-TX) | | Ethernet TCP/IP (10BASE-T/100BASE-TX) (1) |
| USB port for parallel printer | | USB port for parallel printer and RS 232C (COM1) serial link | | |
| SoMachine on Windows XP Professional and Windows 7 Professional 32/64-bit (please refer to our website www.schneider-electric.com) | | | | |
| Magelis (131 MHz RISC CPU) | | Magelis (131 MHz RISC or 266 MHz RISC CPU) (1) | | Magelis (266 MHz RISC CPU) |
| XBTGC1100T | XBTGC2120T | XBTGC2330T | XBTGT2/4/5/6/3/7/3 | XBTGK2/5/3 |
| XBTGC1100U | XBTGC2120U | XBTGC2330U | + XBTZGCANM | + XBTZGCANM |
| 2/92 | | | | |

(1) Depending on model.

Hardware control platforms

HMI controllers

Magelis™ SCU Small HMI Controllers,
 Magelis™ XBTGC HMI Controllers,
 Magelis™ XBTGT, XBTGK Standard Advanced Panels with control

2

Presentation

Magelis HMI Controllers are part of Schneider Electric's Flexible Machine Control concept, a key element in MachineStruxure™.

The Magelis HMI Controllers offer brings together Human Machine Interface and control functions within in a single product. This reduces the amount of equipment required and the associated costs throughout the life cycle of the machine. This offer comprises three ranges:

- The ultra-compact range: Magelis SCU Small HMI Controllers
- The compact range: Magelis XBTGC HMI Controllers
- The modular range: Magelis XBTGT/GK Standard Advanced Panels + XBT ZC CANM CANOpen module

Magelis SCU Small HMI Controllers (ultra-compact range)

The Magelis SCU Small HMI Controllers integrate, as standard, all their functions. They benefit, in particular, from the same innovation as the Magelis STU Small panels range: Mounting via a 22 mm diameter hole (pushbutton type) which considerably simplifies installation (see page 2/84).

Of modular design, this range comprises:

- 2 complete Magelis SCU products for the control of simple machines, comprising:
 - A 3.5" or 5.7" 65 k colour TFT Screen module
 - A Controller module with 16 integrated digital inputs/10 integrated digital outputs
- 2 complete Magelis SCU products for the control of simple processes, comprising:
 - A 3.5" or 5.7" 65 k colour TFT Screen module
 - A Controller module with 8 integrated digital inputs/8 integrated digital outputs and 4 integrated analog inputs/2 integrated analog outputs

The Screen modules and Controller modules (for simple machines or processes) are also available separately as replacement parts. Magelis SCU Small HMI Controllers operate with the same Screen modules as Magelis STU Small panels, which simplifies upgrading of an installation (only the rear module needs to be replaced). A wide choice of communication interfaces is also integrated: USB port, serial link, Ethernet and CANopen.

Magelis XBTGC HMI Controllers (compact range)

The compact design of Magelis XBTGC HMI Controllers optimises setup.

This range comprises 6 touch screen terminals, with the following, depending on the model:

- 3.8" monochrome screen, 12 integrated inputs/6 integrated outputs (sink or source)
- 5.7" monochrome or colour screen, 16 integrated inputs/16 integrated outputs (sink or source)
- A wide choice of communication interfaces: USB port, serial link, Ethernet and CANopen

In order to adapt easily to different configurations, it is possible to add digital or analog I/O expansion modules at the rear of the Controller.

Magelis XBTGT/GK Standard Advanced Panels + XBT ZC CANM CANOpen module (modular range)

This range is made up of the complete Magelis XBTGT or Magelis XBTGK Standard Advanced Panels offers combined with a Control part using the XBTZG CANM CANOpen module. During operation, this module controls the I/O and the peripherals distributed via the CANopen bus.

The combination with Magelis XBTGT or Magelis XBTGK Standard Advanced Panels gives a wide choice of screen sizes and types of data entry, depending on the model:

- 17 XBTGT touch screen terminals:
 - 5.7" monochrome or colour screens
 - 7.5", 10.4", 12.1" and 15" colour screens
- 3 XBTGK terminals with keypad and/or touch screen:
 - 5.7" monochrome or colour screens
 - 10.4" colour screens

This combination also offers numerous advanced functions such as video, data management (sharing of data, log), etc.



Magelis SCU Small HMI Controllers



Magelis XBTGC HMI Controllers



XBTGT Advanced panels



XBTGK Advanced panels

Module XBTZG CANM

HMI function: Magelis XBTGT/GK Advanced Panels
 + control function: CANopen XBTZG CANM master module

Hardware control platforms

HMI controllers

Magelis™ SCU Small HMI Controllers,
 Magelis™ XBTGC HMI Controllers,
 Magelis™ XBTGT, XBTGK Standard Advanced Panels with control



SoMachine



Vijeo Designer
 (included in SoMachine)

Operation

With their fast multitasking processors, all the HMI Controllers combine HMI and control functions and share the same screen and communication features and dimensions.

The internal memory can be freely used by both the HMI function and the control function.

Processing is split 75% on the HMI part and 25% on the control part. The processing can be configured for 3 tasks, including 1 master task.

The XBTGC HMI Controllers also share the same I/O modules, the same Telefast pre-wired system and the same peripherals on the CANopen bus as the Modicon M238 logic controller.

Configuration

Magelis SCU Small HMI Controllers, Magelis XBTGC HMI Controllers and Magelis XBTGT/GK Standard Advanced Panels are configured using Schneider Electric's unique machine automation software, SoMachine.

This software, combining both HMI and control functions, is based on Vijeo Designer software running on Windows XP Professional or Windows 7 Professional 32/64-bit. SoMachine software boasts an advanced user interface with many configurable windows, enabling unique projects to be developed quickly and easily.

See page 5/2.

Communication

Examples of communication architectures

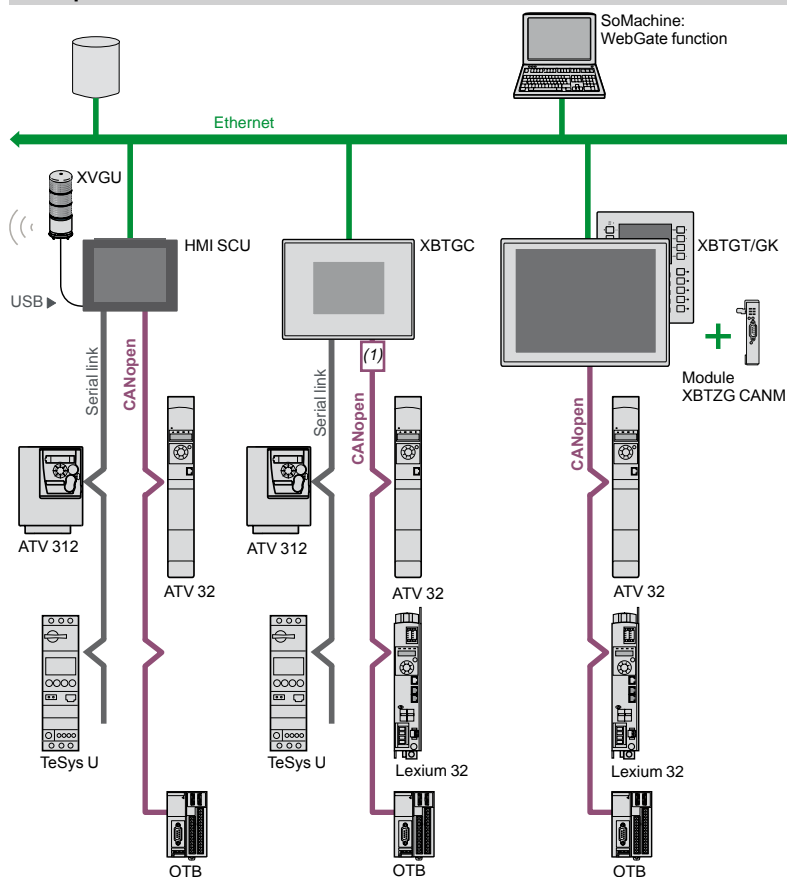

Depending on the model, Magelis SCU Small HMI Controllers, Magelis XBTGC HMI Controllers and Magelis XBTGT/GK Standard Advanced Panels communicate with automation devices via 1 or 2 integrated serial links using the following communication protocols:

- Schneider Electric (Uni-TE, Modbus)
- Third-party: Mitsubishi Electric, Omron, Allen-Bradley and Siemens

Depending on the model, they can be connected to Ethernet TCP/IP networks with the Modbus TCP protocol or a third-party protocol, and can be used as the CANopen master to control all the peripherals which can be connected on this bus.

(1) With XBTZG CAN CANopen master module.

Hardware control platforms

HMI controllers

Magelis™ SCU Small HMI Controllers,

Magelis™ XBTGC HMI Controllers,

Magelis™ XBTGT, XBTGK Standard Advanced Panels with control

Functions

Magelis Small HMI Controllers, Magelis HMI Controllers and Magelis Standard Advanced Panels are part of Schneider Electric's Flexible Machine Control concept, a key element in MachineStruxure™.

Magelis SCU Small HMI Controllers, Magelis XBTGC HMI Controllers and Magelis XBTGT/GK Standard Advanced Panels

Magelis SCU Small HMI Controllers, Magelis XBTGC HMI Controllers and Magelis XBTGT/GK Standard Advanced Panels offer the following HMI functions:

- Display of animated mimics with 8 types of animation (pressing the touch panel, colour changes, filling, movement, rotation, size, visibility and value display)
- Control, modification of numeric and alphanumeric values
- Display of current time and date
- Real-time curves and trend curves with log
- Alarm display, alarm log and management of alarm groups
- Multiwindow management
- Page calls initiated by the operator
- Multilingual application management (10 languages simultaneously)
- Recipe management
- Data processing via Java script
- Application support and USB key external memory logs
- Management of serial printers, barcode readers

Magelis SCU Small HMI Controllers, Magelis XBTGC HMI Controllers and Magelis XBTGT and XBT GK Standard Advanced Panels (1) have been designed for Transparent Ready architectures and equipment (combination of Web and Ethernet TCP/IP technologies).

With the WebGate function, it is possible to control or carry out maintenance remotely.

Eventually, Magelis SCU and Magelis XBTGT/GK will enable a smartphone or a PC tablet to be remotely connected to the HMI application.

Magelis SCU Small HMI Controllers, Magelis XBTGC HMI Controllers and Magelis XBTGT/XBT GK Standard Advanced Panels offer the following HMI functions:

- Execution of programmed logic sequences with the five IEC 1131-2 languages (LD, ST, FBD, SFC, IL)
- Management of equipment on the CANopen fieldbus

Magelis SCU Small HMI Controllers

In addition to the aforementioned functions, Magelis SCU Small HMI Controllers enable management of:

- Integrated digital I/O
- Integrated analog I/O: Voltage, current and temperature (thermocouple, PT100, PT1000)
- 2 high speed counter (HSC) inputs, 100 kHz 1 channel or 50 kHz 2 channel
- 2 pulse train fast outputs, PTO/PWM 50 kHz

Magelis XBTGC HMI Controllers

In addition to the aforementioned functions, Magelis XBTGC HMI Controllers enable management of:

- Integrated digital I/O
- integrated analog I/O
- 4 high speed counter (HSC) inputs, 100 kHz 1 channel or 50 kHz 2 channel
- 4 pulse train fast outputs, PTO/PWM 65 kHz

(1) Depending on model.

Hardware control platforms

HMI controllers

Magelis™ SCU Small HMI Controllers,

Magelis™ XBTGC HMI Controllers,

Magelis™ XBTGT, XBTGK Standard Advanced Panels with control

Operating modes for the terminals

The following illustrations show the equipment that can be connected to Magelis SCU and XBTGC Controllers as well as to Magelis XBTGT/GK Advanced Panels according to their two operating modes.

Edit mode

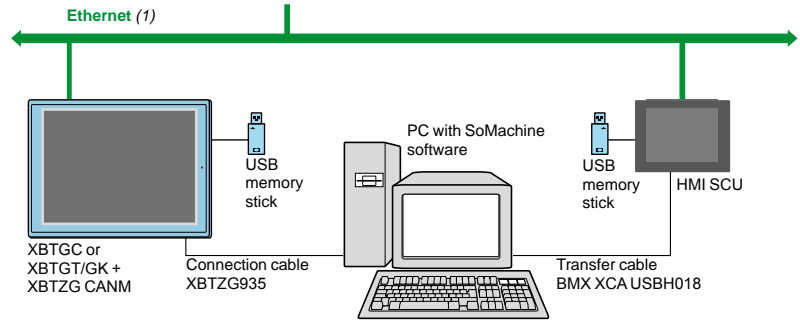

Run mode

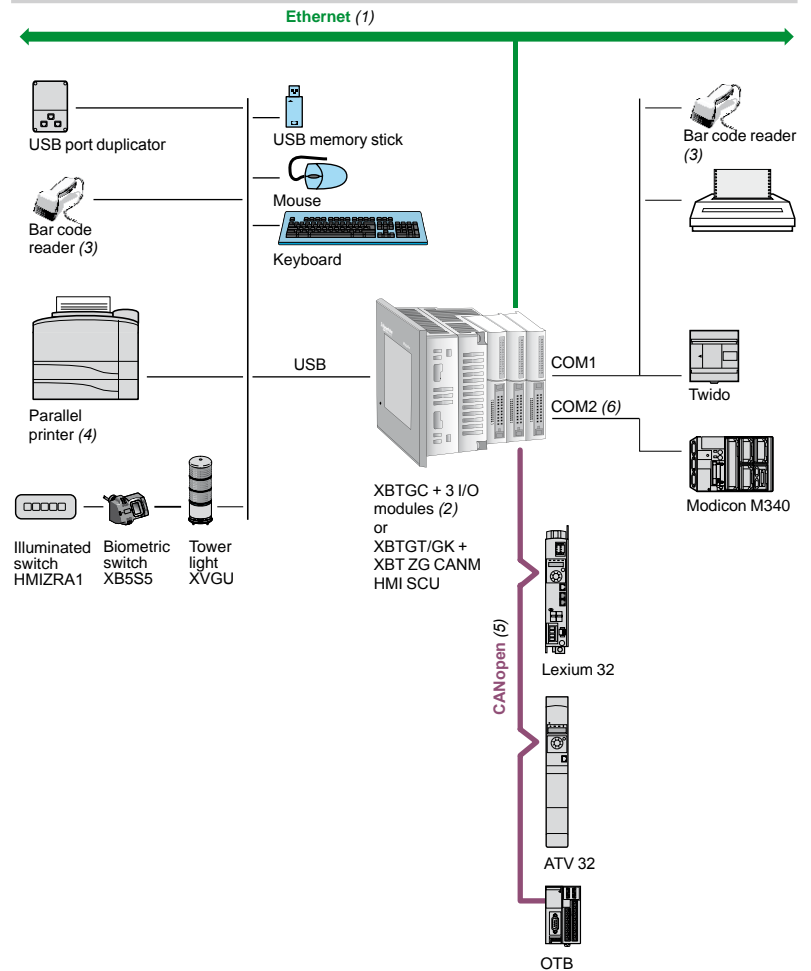

(1) With HMISCU●●●, XBTGC2230T/U, XBTGT●●30, XBTGT●●40, XBTGK●●30.

(2) With XBTGC●●●●T/U, maximum of 2/3 I/O modules depending on model.

(3) Should be a Gryphon barcode reader made by DataLogic except for HMI SCU.

(4) Should be a Hewlett Packard printer via a USB/PIO converter.

(5) Requires:

- for XBTGC: XBTZGCCAN CANopen master module

- for XBTGT/GK: XBTZGCANM CANopen master module.

(6) With XBTGT/GK.

Hardware control platforms

HMI controllers

Magelis™ SCU Small HMI controllers

Magelis™ SCU Small HMI controllers for control of simple machines

2

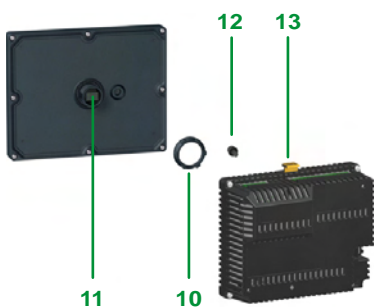
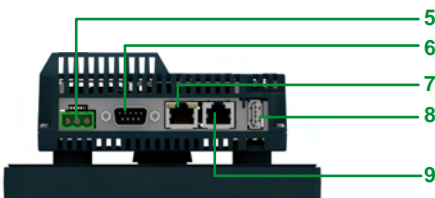
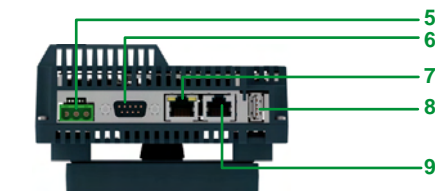
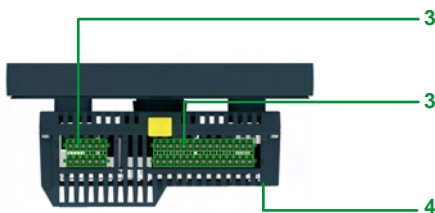
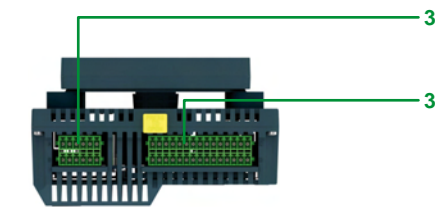

Description

Magelis HMI SCU●A5 Small HMI controllers

Front Panel

Magelis SCU Small HMI controllers for control of simple machines have the following on the front panel:

- 1 A 3.5" touch screen for displaying mimics (color TFT LCD)
- or
- 2 A 5.7" touch screen for displaying mimics (color TFT LCD)

Upper rear panel

The upper rear panel has the following:

- 3 Four removable terminal blocks for 16 digital inputs including 2 high speed counter (HSC) inputs (100 kHz 1 channel or 50 kHz 2 channel), 8 digital relay outputs and 2 source transistor outputs (PTO/PWM 50 kHz or 20 kHz pulse train if HSC used)

Lower rear panel

The lower rear panel has the following:

- 4 A USB mini-B device connector for application transfer (on left-hand side of panel)
- 5 A removable screw terminal block for 24 V $\bar{\text{---}}$ power supply
- 6 A 9-way SUB-D connector for CANopen link, fitted with an LED for signalling power supply and system operation status
- 7 An RJ45 connector for Ethernet TCP/IP, 10BASE-T/100BASE-TX link
- 8 A type A USB master connector for:
 - Connection of a peripheral device
 - Connection of a USB memory stick
 - Application transfer
- 9 An RJ45 male connector for RS 232C or RS 485 serial link connection to PLCs (COM1)

Fixing system

Magelis SCU Small HMI controllers consist of a front module (comprising the screen) and a rear module (comprising the CPU plus terminals and connectors). The two modules are fixed together via a hole measuring 22 mm in diameter.

The fixing system contains the following elements:

- 10 A fixing nut
- 11 A seal
- 12 An anti-rotation tee (can be used as an option)
- 13 A release mechanism: Simply press to separate the two modules once they have been fixed together

This system is included with the complete products (see page 2/87).

Note: The 2 modules can also be mounted separately: Using a remote connection cable enables the rear module and the front module to be separated and the Controller module mounted on DIN rail (see page 2/87).

Hardware control platforms

HMI controllers

Magelis™ SCU Small HMI controllers

Magelis™ SCU Small HMI controllers for control of simple processes

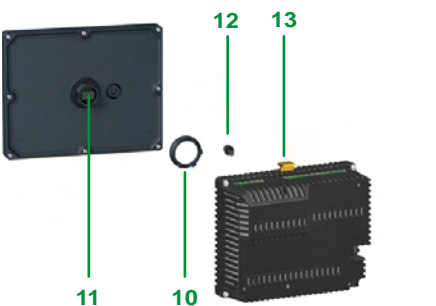
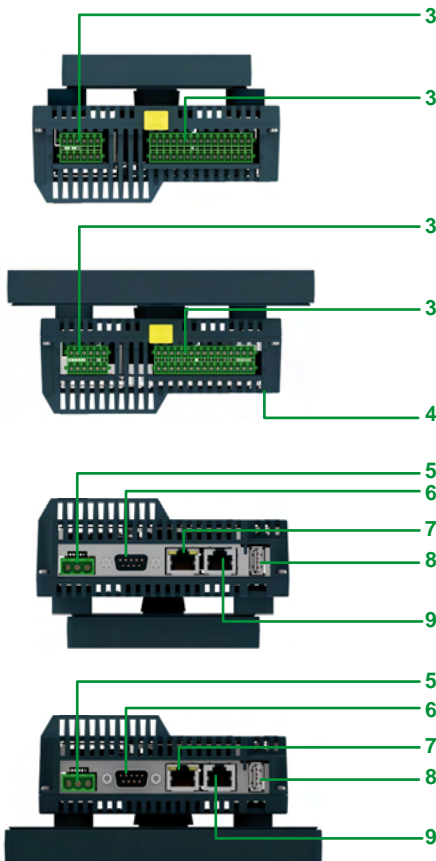

Description

Magelis HMI SCU●B5 Small HMI controllers

Front panel

Magelis SCU Small HMI controllers for control of simple processes have the following on the front panel:

- 1 A 3.5" touch screen for displaying mimics (color TFT LCD)
- or
- 2 A 5.7" touch screen for displaying mimics (color TFT LCD)

Upper rear panel

The upper rear panel has the following:

- 3 Four removable terminal blocks for 8 digital inputs including 2 fast HSC inputs (100 KHz 1 channel or 50 kHz 2 channel), 6 digital relay outputs, 2 transistor source outputs (PTO/PWM 50 kHz or 20 kHz pulse train if HSC used), 2 analog inputs (voltage, current), 2 temperature inputs (Thermocouple, PT100, PT1000) and 2 analog outputs (voltage, current)

Lower rear panel

The lower rear panel has the following:

- 4 A USB mini-B device connector for application transfer (on left-hand side of panel)
- 5 A removable screw terminal block for 24 V $\bar{\square}$ power supply
- 6 A 9-way SUB-D connector for CANopen link, fitted with an LED for signalling power supply and system operation status
- 7 An RJ45 connector for Ethernet TCP/IP, 10BASE-T/100BASE-TX link
- 8 A type A USB master connector for:
 - Connection of a peripheral device
 - Connection of a USB memory stick
 - Application transfer
- 9 An RJ45 male connector for RS 232C or RS 485 serial link connection to PLCs (COM1)

Fixing system

Magelis HMI SCU Small HMI controllers consist of a front module (comprising the screen) and a rear module (comprising the CPU plus terminals and connectors). The two modules are fixed together via a hole measuring 22 mm in diameter.

The fixing system contains the following elements:

- 10 A fixing nut
- 11 A seal
- 12 An anti-rotation tee (can be used as an option)
- 13 A release mechanism: Simply press to separate the two modules once they have been fixed together

This system is included with the complete products (see page 2/87).

Note: The 2 modules can also be mounted separately: Using a remote connection cable enables the rear module and the front module to be separated and the Controller module mounted on DIN rail (see page 2/87).

Hardware control platforms

HMI controllers

Magelis™ SCU Small HMI controllers

CANopen

Presentation

Magelis SCU Small HMI controllers integrate the CANopen bus master function.

SoMachine software is used to configure the CANopen machine bus (1) for the Magelis SCU Small HMI controllers (1).

Example architecture

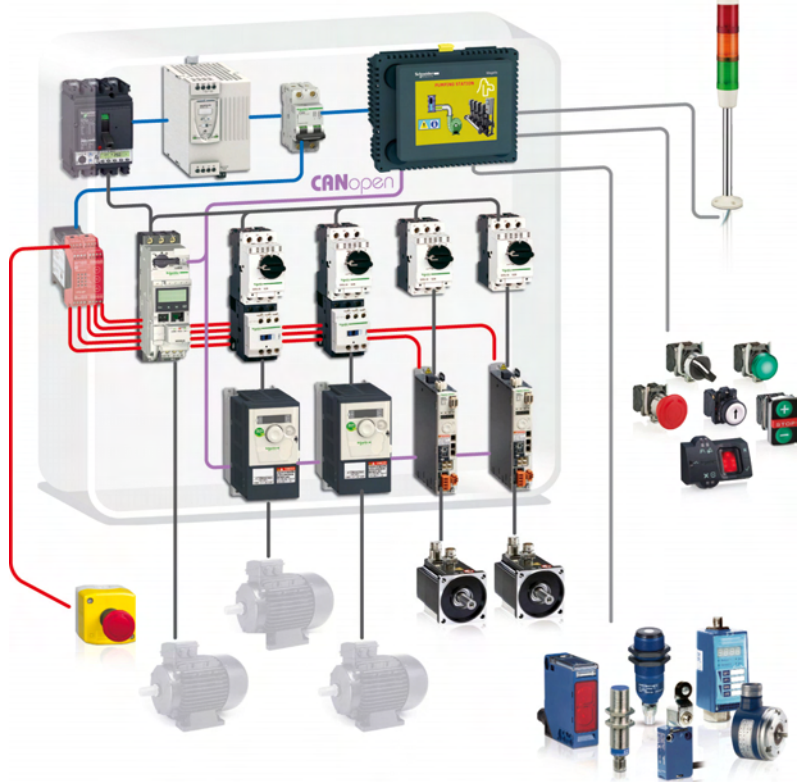

The above configuration shows an example architecture based on the Magelis SCU Small HMI controllers which provide the CANopen bus master function. The CANopen bus is made up of a master station, a Magelis SCU Small HMI Controller and slave stations. The master is responsible for the configuration, exchanges and diagnostics to the slaves.

The various services offered are:

- One or more profiles are supplied for Schneider Electric slaves such as ATV 312/61/71 variable speed drives and Lexium 32 servo drives. This makes it possible to configure the slave according to a predefined mode. Profiles provide the user with a defined operating mode so there is no need to check how the mode is configured.
- For third-party slaves:
 - The user can choose from a list which can be modified. This simply involves importing an EDS-type (Electronic Data Sheet) description file.
 - The slave can be positioned on the bus: The slave number, speed, monitoring, etc. can be defined.
 - The user can select variables from the list of variables managed by the slave.
 - A link between variables and the data exchanged.
 - Symbolization of data exchanged.

The CANopen bus is used to manage various slaves such as:

- Digital and analog slaves
- Variable speed drives, motor starters, etc.

(1) For more information on SoMachine software and CANopen bus, please refer to our website www.schneider-electric.com.



HMISCU6●5



HMISCU8●5



XBTZGUSB



HMIZSURDP●

Magelis HMISCU●A5 Small HMI controllers for control of simple machines (1)

Complete products 24 V --- (Screen module + Controller module)

| Type of screen | No. of ports | Application memory capacity | Compact Flash memory | Integrated I/O | No. of Ethernet ports | Reference | Weight kg/lb |
|---------------------|------------------------------|-----------------------------|----------------------|-------------------------------|-----------------------|-----------|-----------------|
| 3.5" QVGA color TFT | 2 USB 1 COM1 1 CANopen | 128 MB | No | 16 digital I/ 10 digital O | 1 | HMISCU6A5 | 0.512/ 1.129 |
| 5.7" QVGA color TFT | 2 USB 1 COM1 1 CANopen | 128 MB | No | 16 digital I/ 10 digital O | 1 | HMISCU8A5 | 0.764/ 1.684 |

Magelis HMISCU●B5 Small HMI controllers for control of simple processes (1)

Complete products 24 V --- (Screen module + Controller module)

| Type of screen | No. of ports | Application memory capacity | Compact Flash memory | Integrated I/O | No. of Ethernet ports | Reference | Weight kg/lb |
|---------------------|------------------------------|-----------------------------|----------------------|--|-----------------------|-----------|-----------------|
| 3.5" QVGA color TFT | 2 USB 1 COM1 1 CANopen | 128 MB | No | 8 digital I/8 digital O 4 analog I/ 2 analog O | 1 | HMISCU6B5 | 0.551/ 1.215 |
| 5.7" QVGA color TFT | 2 USB 1 COM1 1 CANopen | 128 MB | No | 8 digital I/8 digital O 4 analog I/ 2 analog O | 1 | HMISCU8B5 | 0.803/ 1.770 |

Separate parts

| Description | Compatibility | Reference | Weight kg/lb | |
|--|--|-------------|-----------------|--------------|
| Protective sheets (5 peel-off sheets) | HMISCU6●● | XBTZG61 | 0.200/ 0.441 | |
| | HMISCU8●● | XBTZG62 | 0.200/ 0.441 | |
| Designation | Description | Length m/ft | Reference | Weight kg/lb |
| Remote USB port location for type A terminal | Enables the USB port to be located remotely on the rear of the HMI terminal on a panel or cabinet door (Ø 21 mm fixing device) | 1.0/3.28 | XBTZGUSB | – |
| Remote USB port location for mini type B terminal | | – | HMIZSUSBB | – |
| Remote Controller module connection cable | Enables separate mounting of the Controller module and Screen module on DIN rail (for example, inside an enclosure) | 3.0/9.84 | HMIZSURDP | – |
| | | 5.0/16.40 | HMIZSURDP5 | – |
| Cable for transferring application to PC | USB type connector | 1.8/5.90 | BMXXCAUSBH018 | – |
| Accessories kit (compatible with all Magelis SCU Small controllers) | Contains: ■ An anti-rotation tee ■ A USB A type clip ■ A USB mini-B type clip ■ An adaptor panel for mounting on an enclosure of 1 mm in thickness | – | HMIZSUKIT | – |

Replacement parts

| Description | For use with | Reference | Weight kg/lb |
|----------------------------------|--|-----------|-----------------|
| Direct I/O connector | All Magelis SCU Small controllers | HMIZSDIO | – |
| 3.5" Screen module | Controller modules HMISAC and HMISBC | HMIS65 | 0.153/ 0.337 |
| 5.7" Screen module | Controller modules HMISAC and HMISBC | HMIS85 | 0.405/ 0.893 |
| Simple machine Controller module | Screen modules HMIS65 (3.5") and HMIS85 (5.7") | HMISAC | 0.359/ 0.791 |
| Simple process Controller module | Screen modules HMIS65 (3.5") and HMIS85 (5.7") | HMISBC | 0.398/ 0.877 |
| Fixing nuts | Set of 10 Ø 22 mm nuts (the front module of the SCU Small controller is fixed on the enclosure using a Ø 22 mm nut, see page 2/84) | ZB5AZ901 | – |
| Tightening tool | For tightening fixing nut | ZB5AZ905 | – |

(1) Mounting system for Ø 22 mm hole, power supply and I/O connectors, locking device for USB connector and instruction sheet included with terminals. The setup documentation for Magelis SCU Small controllers is supplied in electronic format with the SoMachine software (please refer to our website www.schneider-electric.com).

Hardware control platforms

HMI Controllers

Magelis XBTGC HMI Controller, Magelis XBTGT/GK Advanced Panels + control function

2



Magelis XBTGC HMI Controller



XBT GT Advanced panels

XBT GK Advanced panels

XBT ZG CANM module



HMI function: Magelis XBT GT/GK Advanced Panels
+
Control function: XBTZG CANM CANOpen master module

Presentation

The Magelis HMI Controller offer forms a part of Flexible Machine Control approach, a key component of MachineStruxure™, which brings you maximum flexibility and ensures the most optimised control solution.

The Magelis HMI Controller offer brings together HMI and control functions within in a single product. This reduces the amount of equipment required and the associated costs throughout the life cycle of the machine.

This offer comprises two ranges:

- The compact range: Magelis XBTGC HMI Controller
- The modular range: Magelis XBTGT/GK Advanced Panels + XBTZC CANM CANOpen module

Magelis XBTGC HMI Controllers (compact range)

Magelis XBTGC HMI Controllers optimize setup due to their compact design.

This range comprises 6 touch screen terminals, with the following, depending on the model:

- 3.8" monochrome screen, 12 integrated inputs/6 integrated outputs (sink or source)
- 5.7" monochrome or colour screen, 16 integrated inputs/16 integrated outputs (sink or source)
- A wide choice of communication interfaces: USB, serial link, CANOpen and Ethernet

In order to adapt easily to different configurations, it is possible to add discrete I/O expansion modules at the rear of the Controller.

Magelis XBTGT/GK Advanced Panels + XBTZC CANM CANOpen module (modular range)

This range comprises complete Magelis XBT GT or Magelis XBT GK Advanced Panel offers to which a control part is added with the CANOpen module XBTZG CANM. During operation, this module controls the I/O and the peripherals distributed via the CANOpen bus.

The combination with Magelis XBT GT or Magelis XBT GK Advanced Panels gives a wide choice of screen sizes and types of data entry, depending on the model:

- 17 XBT GT touch screen terminals:
 - 5.7" monochrome or colour screens
 - 7.5", 10.4", 12.1" and 15" colour screens
- 3 XBT GK terminals with keypad and/or touch screen:
 - 5.7" monochrome or colour screens
 - 10.4" colour screens

This combination also offers numerous advanced functions such as video, data management (sharing of data, log), etc.

Operation

With their fast, multitasking processors, all the HMI Controllers combine HMI and control functions and share the same screen and communication features and dimensions.

The internal memory can be freely used by both the HMI function and the control function.

Processing is split 75% on the HMI part and 25% on the control part. The processing can be configured for 3 tasks, including 1 master task.

XBTGC HMI Controllers also have the same I/O modules, the same Telefast pre-wired system and the same peripherals on the CANOpen bus as the M238 logic controller.

Hardware control platforms

HMI Controllers

Magelis XBTGC HMI Controller, Magelis XBTGT/GK Advanced Panels + control function



SoMachine



Vijeo Designer
(included in SoMachine)

Configuration

Magelis XBTGC HMI Controllers and Magelis XBTGT/GK Advanced Panels can be configured with Schneider Electric's unique machine automation software: SoMachine. (See page 5/2)

This software, combining both HMI and control functions, is based on the Vijeo Designer software in the Windows XP and Windows Vista environment. The SoMachine software boasts an advanced user interface with many configurable windows, enabling unique projects to be developed quickly and easily.

Communication

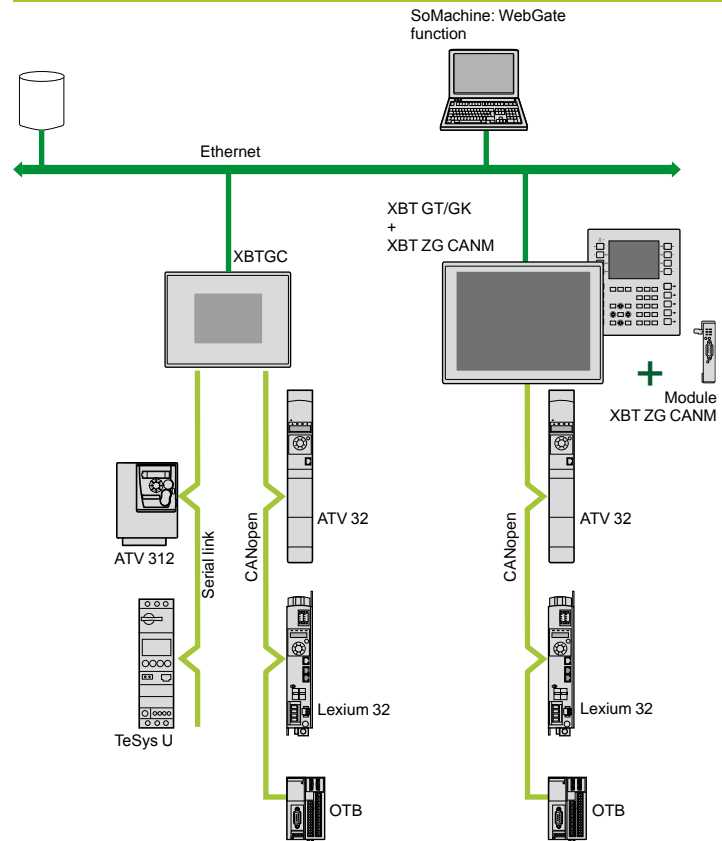

Examples of communication architectures

Depending on the model, Magelis XBTGC HMI Controllers and Magelis XBTGT/GK Advanced Panels communicate with automation equipment via 1 or 2 integrated serial links, based on communication protocols:

- Schneider Electric (Uni-TE, Modbus)
- Third party: Mitsubishi Electric, Omron, Allen-Bradley and Siemens

Depending on the model, they can be connected to Ethernet TCP/IP networks with the Modbus TCP protocol or a third-party protocol, and can be used as the CANopen master to control all the peripherals which can be connected on this bus.

Hardware control platforms

HMI Controllers

Magelis XBTGC HMI Controller, Magelis XBTGT/GK Advanced Panels + control function

Functions

Magelis XBTGC HMI Controllers and Magelis XBTGT/GK Advanced Panels offer the following HMI functions:

- Display of animated mimics with 8 types of animation (pressing the touch panel, colour changes, filling, movement, rotation, size, visibility and value display)
- Control, modification of numeric and alphanumeric values
- Display of current date and time
- Real-time curves and trend curves with log
- Alarm display, alarm log and management of alarm groups
- Multi-window management
- Page calls initiated by the operator
- Multilingual application management (10 languages simultaneously)
- Recipe management
- Data processing via Java script
- Application support and USB key external memory logs
- Management of serial printers and barcode readers

Magelis XBTGC HMI Controllers and Magelis XBTGT/GK Advanced Panels (1) have been designed for Transparent Ready architectures and equipment (combination of web and Ethernet TCP/IP technologies).

With the WebGate function, it is possible to control or carry out maintenance remotely.

They offer the following control functions:

- Execution of programmed logic sequences with the 5 IEC 1131-2 languages (LD, ST, FBD, SFC, IL)
 - Management of equipment on the CANopen fieldbus
- In addition to these functions, Magelis XBTGC HMI Controllers can manage:
- Discrete I/O on integrated or remote expansion modules
 - Analog I/O on remote expansion modules

(1) Depending on model

Hardware control platforms

HMI Controllers

Magelis XBTGC HMI Controller, Magelis XBTGT/GK Advanced Panels + control function

Operating modes for the terminals

The illustrations below show which equipment can be connected to XBT terminals based on their two operating modes.

Edit mode

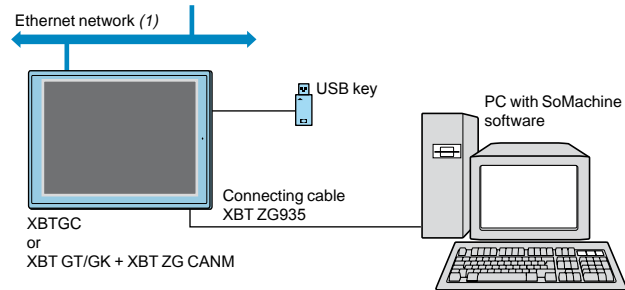

Run mode

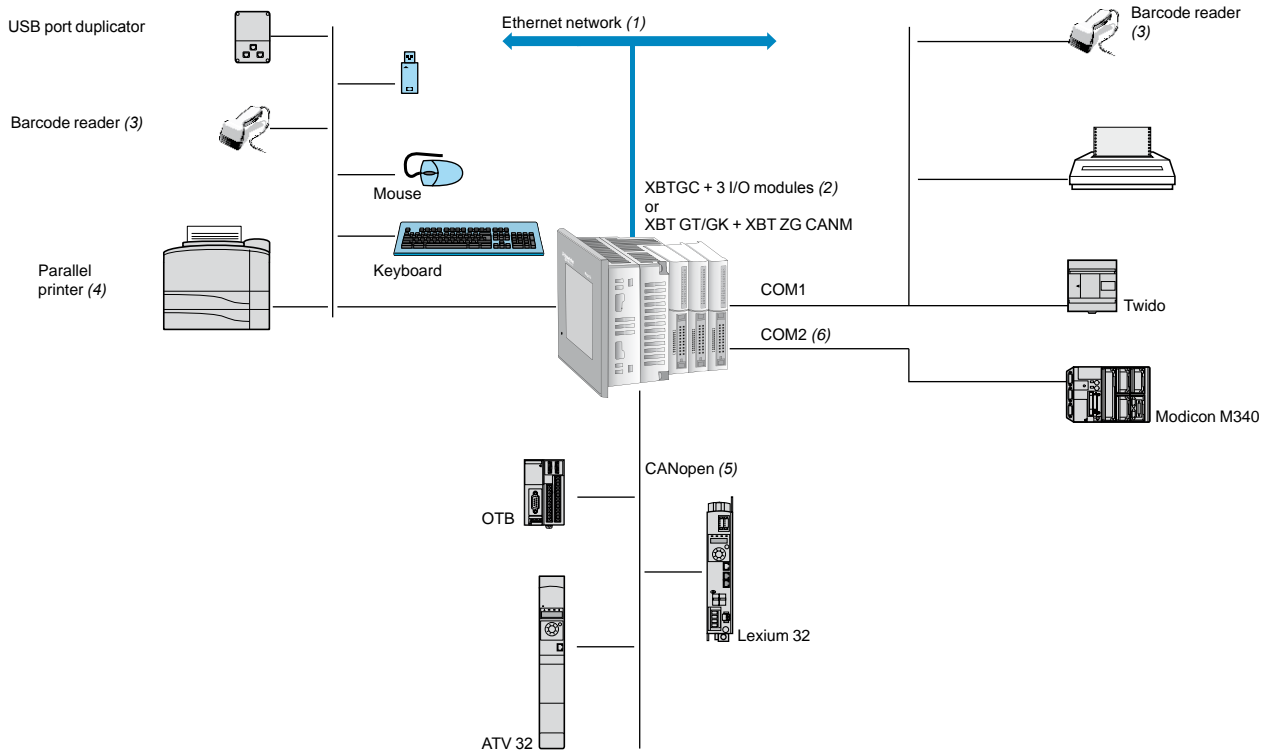

(1) With XBTGC2230T/U, XBTGT●●30, XBTGT●●40, XBTGK●●30

(2) With XBTGC ●●●●T/U

(3) Should be a DataLogic Gryphon barcode reader

(4) Should be a Hewlett Packard printer via a USB/PIO converter

(5) Requires:

- For XBTGC: XBTZGC CAN CANopen master module

- For XBTGT/GK: XBTZG CANM CANopen master module

(6) With XBTGT/GK

Hardware control platforms

HMI Controllers

Magelis XBTGC HMI Controller with 3.8" screen

2

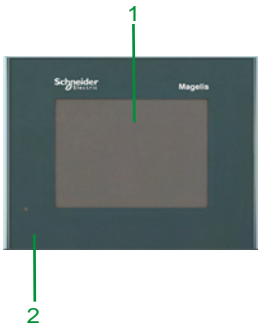

Description

Magelis XBTGC1100 T/U HMI Controller

The front panel comprises:

- 1 A touch screen for displaying mimics (3.8" amber or red mode monochrome)
- 2 A control indicator showing the terminal's operating mode

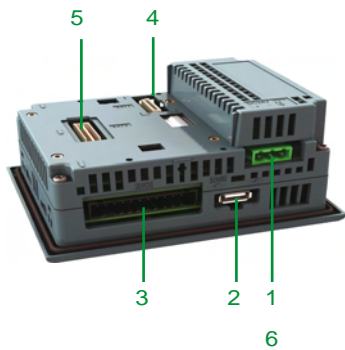

The rear panel comprises:

- 1 A removable screw terminal block for the 24 V $\bar{\text{---}}$ power supply
- 2 A type A USB master connector for peripheral connection and application transfer
- 3 A removable terminal block for 12 discrete inputs and 6 discrete outputs
- 4 An interface for connecting M238 logic controller I/O expansion modules
- 5 An interface for connecting the CANopen bus master module (see page 4/14)
- 6 Discrete I/O expansion module (TM2 D●●). To be ordered separately (see page 3/6)



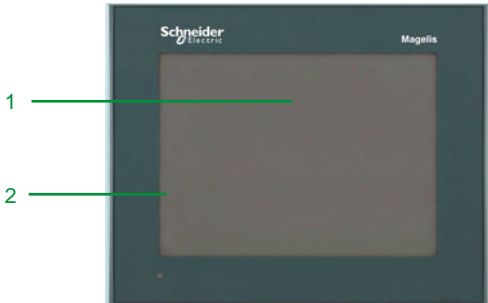

Description

Magelis XBTGC2●20 and XBTGC2●30 HMI Controller

The front panel comprises:

- 1 A touch screen for displaying mimics (5.7" monochrome or colour)
- 2 A multicolour indicator (green, orange and red) showing the terminal's operating mode

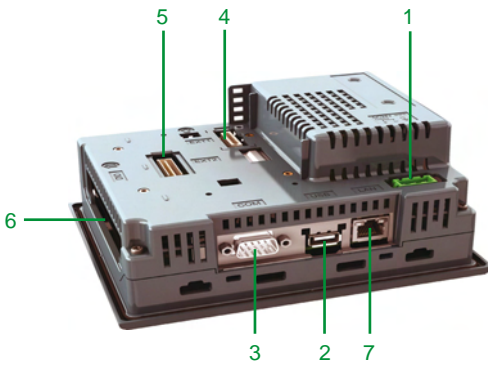

The rear panel comprises:

- 1 A removable screw terminal block for 24 V $\overline{\text{---}}$ supply
- 2 A type A USB master connector for peripheral connection and application transfer
- 3 A 9-way male SUB-D connector for RS 232C or RS 422/485 serial link to PLCs (COM1)
- 4 An interface for connecting the M238 logic controller I/O expansion module
- 5 An interface for connecting the CANopen bus master module (see page 4/17)
- 6 A removable terminal block for 16 discrete inputs and 16 discrete outputs

On XBTGC2330 only:

- 7 An RJ45 connector for Ethernet TCP/IP, 10BASE-T/100BASE-TX connection
- 8 Discrete I/O expansion module (TM2D●●). To be ordered separately (see page 3/6)

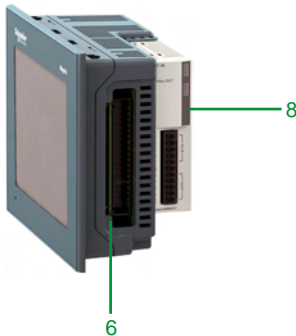

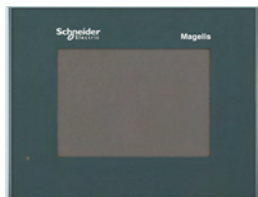

XBTGC1100●



XBTGC2●●●



XBTZGUSB

Magelis XBTGC HMI Controller (1)

| Type of screen | No. of ports | Application memory capacity | Compact Flash memory | Integrated I/O | No. of Ethernet ports | Reference | Weight kg/lb |
|-----------------------------|-----------------|-----------------------------|----------------------|------------------|-----------------------|-------------------|-----------------|
| 3.8" screen | | | | | | | |
| STN amber or red | 1 USB | 16 MB | No | 12 I/6 O source | - | XBTGC1100T | 0.400/ 0.882 |
| | | | | 12 I/6 O sink | - | XBTGC1100U | 0.400/ 0.882 |
| 5.7" screen | | | | | | | |
| STN black and white mode | 1 COM1 1 USB | 16 MB | No | 16 I/16 O source | - | XBTGC2120T | 1.000/ 2.205 |
| | | | | 16 I/16 O sink | - | XBTGC2120U | 1.000/ 2.205 |
| 5.7" screen | | | | | | | |
| STN colour | 1 COM1 1 USB | 16 MB | No | 16 I/16 O source | 1 | XBTGC2230T | 1.000/ 2.205 |
| | | | | 16 I/16 O sink | 1 | XBTGC2230U | 1.000/ 2.205 |

Separate parts

| Designation | Compatibility | Size | Reference | Weight kg/lb |
|---|--|-------------|------------------|-----------------|
| Protective sheets (5 peel-off sheets) | XBTGC1100 | - | XBTZG60 | - |
| | XBTGC2●●0 | - | XBTZG62 | 0.200/ 0.441 |
| Designation | Description | Length m/ft | Reference | Weight kg/lb |
| Remote USB port location for type A XBT terminal | Enables the USB port to be located remotely on the rear of the XBT terminal on a panel or cabinet door (Ø 21 mm fixing device) | 1/ 3.28 | XBTZGUSB | - |
| Remote USB port location for mini type B XBT terminal | | - | XBTZGUSBB | - |
| XBTGC connection to CANopen master fieldbus | Connection via card on expansion bus | - | XBTZGCCAN | - |
| Cable for transferring application to PC | USB connector, type TTL | 2/ 6.56 | XBTZG935 | - |

Replacement parts

| Designation | Use for | Reference | Weight kg/lb |
|--|--|------------------|-----------------|
| Installation gaskets | XBTGC1100 | XBTZG51 | 0.030/ 0.066 |
| | XBTGT21●0 | XBTZG52 | 0.030/ 0.066 |
| USB spring clip | XBTGC1100 | XBTZGCLP2 | - |
| | XBTGC2●●0 | XBTZGCLP4 | - |
| Mounting kit | 4 clips and screws (max. tightening torque: 0.5 Nm), supplied with all XBTGC terminals | XBTZGFIX | 0.100/ 0.220 |
| Spring clip for expansion modules on XBTGC | XBTGC2●●0 terminals | XBTZGCHOK | 0.030/ 0.066 |
| Power supply connector | XBTGC1●●●/GC2●●● | XBTZGPWS1 | 0.030/ 0.066 |
| Direct I/O connector | XBTGC1000 | XBTZGDIO1 | - |
| | XBTGC2000 | XBTZGDIO2 | - |

(1) Terminals supplied with fixing kit (clips with screws), locking catch for USB connectors, spring clip for expansion modules (except XBTGC1100) and instruction sheets. The setup documentation for XBTGC terminals is supplied in electronic format with the SoMachine software (see page 5/5).



XBTGC1●●● Combining two TM2 expansion modules (1)

| Combinations | Type | Type | Total thickness (mm) | Combination |
|--------------|------|------|----------------------|-------------|
| A | A | A | 35.2 | Authorized |
| A | B | B | 41.1 | |
| B | B | B | 47.0 | |
| A | C | C | 47.3 | |
| B | C | C | 53.2 | |
| A | D | D | 56.7 | |
| C | C | C | 59.4 | |
| B | D | D | 62.6 | Prohibited |
| C | D | D | 68.8 | |
| D | D | D | 78.2 | |

XBTGC2●●● Combining two TM2 expansion modules (1)

| Combinations | Type | Type | Total thickness (mm) | Combination |
|--------------|------|------|----------------------|-------------|
| A | A | A | 35.2 | Authorized |
| A | B | B | 41.1 | |
| B | B | B | 47.0 | |
| A | C | C | 47.3 | |
| B | C | C | 53.2 | |
| A | D | D | 56.7 | |
| C | C | C | 59.4 | |
| B | D | D | 62.6 | Prohibited |
| C | D | D | 68.8 | |
| D | D | D | 78.2 | |

Combining three TM2 expansion modules (1)

| Combinations | Type | Type | Type | Total thickness (mm) | Combination |
|-----------------------|------|------|------|----------------------|--------------------------|
| A | A | A | A | 52.8 | Authorized with hook (2) |
| A | A | A | B | 58.7 | |
| A | B | B | B | 64.6 | |
| B | B | B | B | 70.5 | |
| Any other combination | | | | | Prohibited |

(1) Modicon TM2 expansion modules: see page 3/6.

(2) Hook supplied with the product

Hardware control platforms

HMI Controllers

Modicon Telefast ABE7 pre-wired system for Magelis XBTGC HMI Controller

Presentation

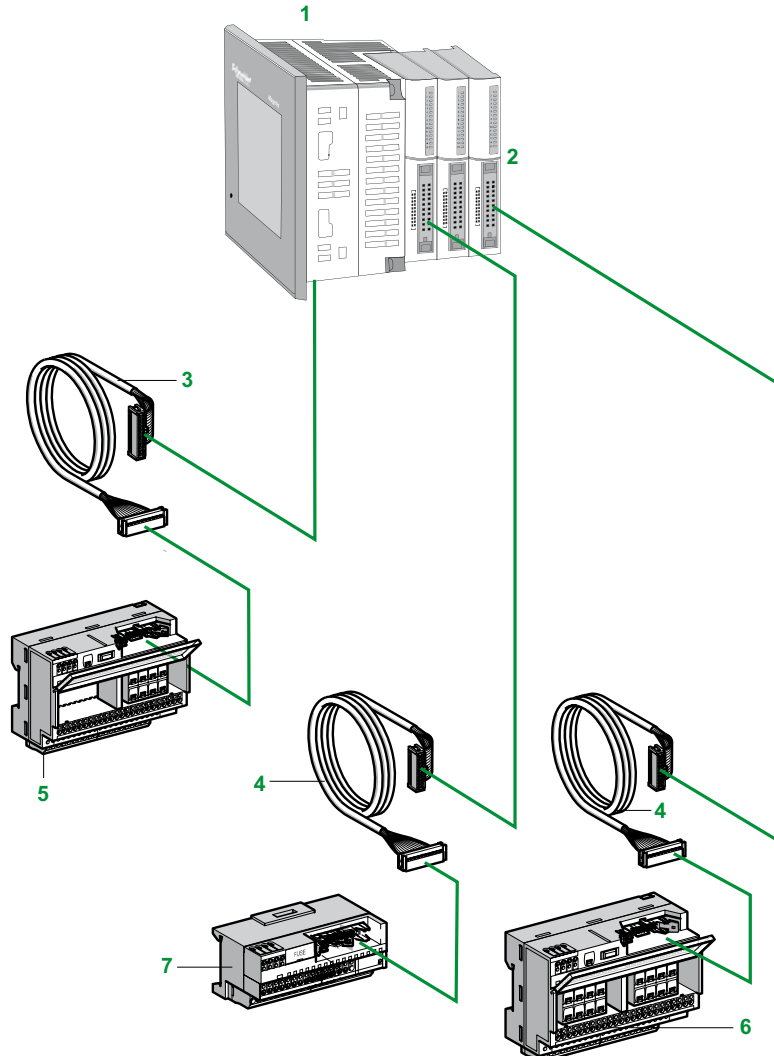

- 1 XBT GC equipped with direct I/O 22 or 38-way connectors. The modularity options offered have 18 or 32 I/O.
- 2 Input and output modules equipped with 20-way HE 10 connectors. The modularity options offered have 16 or 32 I/O.
- 3 2 m AWG 28/0.08 mm² cables, depending on the model:
 - For **XBTGC1100T/U**: **XBTZGABE1** cable equipped with a 26-way HE 10 connector and a 22-way direct I/O-XBT GC connector at each end.
 - For **XBTGC2●●●T/U**: **XBTZGABE2** cable equipped with two 20-way HE10 connectors and a 38-way direct I/O-XBT GC connector.
- 4 **ABFT20E●●●** cable equipped with a 20-way HE 10 connector at each end. This cable is available in 0.5, 1, 2 and 3 metre lengths (AWG 28/0.08 mm²).
- 5 Depending on model:
 - For **XBTGC1100T**: **ABE7B20MPN2●** or **ABE7B20MRM20** 20 channel sub-base for bases.
 - For **XBTGC 2●●●T**: **ABE7E16EPN20** or **ABE7E16SPN2●** 16-channel sub-base.
- 6 **ABE7E16SPN22** or **ABE7E16SRM20** 16-channel sub-base for output expansion modules.
- 7 **ABE7E16EPN20** or **ABE7E16SPN20** 16-channel sub-base for input or output expansion modules.

| Combinations involving modular bases and I/O expansion modules | | | | | | |
|--|--------------------|------------|--------------------|-------------|--|--|
| | XBTGC | | | | Discrete I/O expansion modules | |
| | Integrated I/O | | | | Inputs | Outputs (source) |
| | XBTGC1100T | | XBTGC2●●●T | | TM2DDI16DK (16 I) TM2DDI32DK (32 I) | TM2DDO16TK (16 O) TM2DDO32TK (32 O) |
| Integrated in Twido programmable controllers | 12 I | 6 O source | 16 I | 16 O source | | |
| Types of connection terminal block | Direct I/O, 22-way | | Direct I/O, 38-way | | HE 10, 20-way | |
| Connection to XBT GC HMI programmable controller | XBTZGABE1 | | XBTZGABE2 | | ABFT20E●●0 (HE 10, 20-way) | |
| Passive connection sub-bases | | | | | | |
| 20 channels | ABE7B20MPN2● | | (1) | | | |
| 16 channels | ABE7E16EPN20 | | | | | |
| | ABE7E16SPN2● | | | | | |
| Output adaptor sub-bases | | | | | | |
| 20 channels | ABE7B20MRM20 | | (2) | | | |
| 16 channels | ABE7E16SRM20 | | | | | |

 Compatible
 Not compatible

Note: Telefast cables and modules are not compatible with XBT GC which have sink outputs (suffix U).

(1) 6 channels used out of 8 available

(2) 6 channels used out of 8 available with 2 transistor outputs and 4 relay outputs

Hardware control platforms

HMI Controllers

Modicon Telefast ABE7 pre-wired system for Magelis XBTGC HMI Controller

2



ABE7B20MPN20



ABE7E16EPN20



ABE7E16SRM20

References

For XBTGC 1100T bases

| Number of I/O | No./ type of input | No./ type of output | Compatibility | LED per channel | Fuse | Reference | Weight kg/lb |
|---------------|--|---|---------------|-----------------|------|---------------------|-----------------|
| 20 | 12, sink 24 V $\overline{\text{---}}$ | 6, source 24 V $\overline{\text{---}}$ | XBTGC1100T | No | No | ABE7B20MPN20 | 0.430/ 0.948 |
| | | | | Yes | Yes | ABE7B20MPN22 | 0.430/ 0.948 |
| | 12, sink 24 V $\overline{\text{---}}$ | 2, source 24 V $\overline{\text{---}}$, 2 A and 4, relay 24/250 V $\overline{\text{---}}$ \sim , 3 A | XBTGC1100T | No | No | ABE7B20MRM20 | 0.430/ 0.948 |

For expansion modules or for XBTGC 2000T bases

| Number of inputs | Type of input | Compatibility | LED per channel | Fuse | Reference | Weight kg/lb |
|-------------------|--|---|-----------------|------|---------------------|-----------------|
| 16 | Sink 24 V $\overline{\text{---}}$ | TM2 DDI16DK/ DDI32K and XBTGC2000T | No | No | ABE7E16EPN20 | 0.430/ 0.948 |
| Number of outputs | Type of output | Compatibility | LED per channel | Fuse | Reference | Weight kg/lb |
| 16 | Source 24 V $\overline{\text{---}}$ | TM2 DDO16TK/ DDO32TK and XBTGC2000T | No | No | ABE7E16SPN20 | 0.450/ 0.992 |
| | | | Yes | Yes | ABE7E16SPN22 | 0.450/ 0.992 |
| | Relay 24/250 V $\overline{\text{---}}$ \sim , 3 A | | No | No | ABE7E16SRM20 | 0.430/ 0.948 |

Connection cables for XBTGC

| Type of signal | Compatibility | Connection type | | Gauge Cross-sect. | Length m/ft (1) | Reference | Weight kg/lb |
|----------------|---------------|---|------------------|-----------------------------|-------------------|-------------------|-----------------|
| | | XBTGC side | Telefast side | | | | |
| Discrete I/O | XBTGC 1100T | Direct I/O | HE 10 26-way | AWG 28 0.08 mm ² | 2/ 6.56 | XBTZGABE1 | 0.180/ 0.397 |
| | | Direct I/O | 2 x HE 10 20-way | | 2/ 6.56 | XBTZGABE2 | 0.180/ 0.397 |
| | XBTGC 2000T | HE 10 | HE 10 20-way | AWG 28 0.08 mm ² | 0.5/ 1.64 | ABFT20E050 | 0.060/ 0.132 |
| | | DDI16DK/ DDI32DK/ DDO16TK/ DDO32TK | | | 1/ 3.28 | ABFT20E100 | 0.080/ 0.176 |
| | | | | 2/ 6.56 | ABFT20E200 | 0.140/ 0.309 | |

Accessories

| Designation | Number of shunted terminals | Characteristics | Sold in lots of | Unit reference | Weight kg/lb |
|---------------------------------------|-----------------------------|-----------------|-----------------|-------------------|-----------------|
| Optional snap-on terminal blocks | 20 | – | 5 | ABE7BV20 | 0.060/ 0.132 |
| | 12+8 | – | 5 | ABE7BV20TB | 0.060/ 0.132 |
| Quick-blow fuses 5 x 20, 250 V, UL | – | 0.125 A | 10 | ABE7FU012 | 0.010/ 0.022 |
| | | 0.315 A | 10 | ABE7FU030 | 0.010/ 0.022 |
| | | 1 A | 10 | ABE7FU100 | 0.010/ 0.022 |
| | | 2 A | 10 | ABE7FU200 | 0.010/ 0.022 |

(1) Please contact us for lengths > 2 m.

Hardware control platforms

HMI Controllers

Modicon Telefast ABE7 pre-wired system for Magelis XBTGC HMI Controller

| References (continued) | | | | | | | |
|---|--|--|--------------|---------------------------------|---------------------|------------|---------------------|
| Separate parts | | | | | | | |
| Description | Type | Compatibility | | Reference | Weight kg/ lb | | |
| Connectors Sold in lots of 5 | HE 10 female 26-way | TWD LMDA20DTK/ LMDA40DTK | | TWDFCN2K26 | - | | |
| | HE 10 female 20-way | TM2 DDI16DK/ DDI32DK/ DDO16TK/ DDO32TK | | TWDFCN2K20 | - | | |
| Screw terminals Sold in lots of 5 | 10-way | TM2 DDI16DT/DAI8DT/ DDO8T/DRA8RT | | TWDFTB2T10 | - | | |
| | 11-way | TM2 DMM8DRT/ AMI8T/ARI8HT | | TWDFTB2T11 | - | | |
| Designation | Compatibility | Connection type | | Gauge/ Cross-sect. | Length m/ft | Reference | Weight kg/ lb |
| Cables for discrete I/O | TM2 DDI16DK/ DDI32DK/ DDO16TK/ DDO32TK | HE 10 | Flying leads | AWG 22 0.035 mm ² | 3/ 9.84 | TWDFCW30K | 0.405/ 0.893 |
| | | 20-way | | | 5/ 16.40 | TWDFCW50K | 0.670/ 1.477 |
| Rolled ribbon cable | 20 conductors | - | - | AWG 28 0.08 mm ² | 20/ 65.62 | ABFC20R200 | 1.310/ 2.888 |



chapter 3

Expansion modules



All technical information about products listed in this chapter
are available on www.schneider-electric.com

- **General selection guide**
 - **Local and remote I/O expansion modules** 3/2
 - **Distributed I/O expansion modules** 3/4
- **Modicon TM2 modules**
for HMI controllers
 - **Modicon TM2 Digital modules**
 - Selection guide 3/6
 - Presentation, description, references 3/10
 - **Modicon TM2 Analog modules**
 - Selection guide 3/14
 - Presentation, description, references 3/16
 - **Modicon TM2 expert modules**
 - Presentation, description, references 3/18
- **Modicon TM3 modules**
for Modicon M221, M241 and M251 logic controllers
 - Presentation of the range 3/20
 - **Modicon TM3 Digital modules**
 - Selection guide 3/22
 - Presentation, description, references 3/24
 - **Modicon TM3 Analog modules**
 - Selection guide 3/26
 - Presentation, description, references 3/28
 - **Modicon TM3 expert modules for TeSys motor-starter**
 - Presentation, description, references 3/30
 - **Modicon TM3 Functional Safety modules**
 - Selection guide 3/32
 - Presentation, description, references 3/34
 - **Modicon TM3 bus expansion system** (transmitter and receiver modules)
 - Presentation, description, references 3/36
- **Modicon TM5 modules**
for Modicon M258 logic controller and Modicon LMC058 motion controller
 - **Modicon TM5 compact blocks**
 - Selection guide 3/38
 - Presentation, description, references 3/40
 - **Modicon TM5 Digital modules and Common Distribution modules**
 - Selection guide 3/42
 - Presentation, description, references 3/44 to 3/49
 - **Modicon TM5 Analog modules**
 - Selection guide 3/50
 - Presentation, description, references 3/52
 - **Modicon TM5 Expert modules**
 - Selection guide 3/54
 - Presentation, description, references 3/56
 - **Modicon TM5 Power Distribution modules**
 - Presentation, description, references 3/58
 - **Modicon TM5 transmitter and receiver modules**
 - Presentation, description 3/60
 - References 3/61
- **Modicon TM7 blocks**
for Modicon M258 logic controller and Modicon LMC058 motion controller
 - Presentation 3/64
 - **Digital blocks**
 - Selection guide 3/66
 - Description, references 3/68
 - **Analog blocks**
 - Selection guide 3/70
 - Description, references 3/71
 - **Power distribution blocks**
 - Description, references 3/73
- **Distributed I/O Expansion modules**
 - Modicon OTB interface module 4/18
 - Modicon TM5 CANopen interface module 4/24
 - Modicon TM7 CANopen interface blocks 4/28

Expansion modules

Local and remote I/O expansion modules

| Applications | Local I/O (IP 20) | | | Local and/or remote I/O (IP 20) | | | |
|--------------------------|---|--------|--------|--|--------|--------|--------|
| Compatibility | <ul style="list-style-type: none"> Modicon M238 logic controller XBTGC HMI controllers Modicon OTB | | | <ul style="list-style-type: none"> Modicon M221 logic controllers Modicon M241 logic controller Modicon M251 logic controller | | | |
| I/O type | Digital | Analog | Expert | Digital | Analog | Expert | Safety |
| Remote I/O configuration | <p>Modicon TM3 transmitter/receiver: For use with remote I/O (1)</p> <p>TM3 expansion bus</p> | | | | | | |
| Hardware | - | | | | | | |
| Bus type | - | | | | | | |



| Inputs | Number (depending on model) | Local I/O (IP 20) | | Local and/or remote I/O (IP 20) | | Control of up to four TeSys motor starters | Control of <input type="checkbox"/> Emergency stops <input type="checkbox"/> Switches <input type="checkbox"/> Light curtains <input type="checkbox"/> Sensitive mats or edges |
|---------------------------|---|-------------------------------|---|--|---|---|--|
| | | 4 to 32 inputs | 2 to 8 inputs | 2 channels with 6 inputs | 2 to 32 inputs | | |
| Type (depending on model) | 24 V $\overline{\text{DC}}$ 120 V \sim | Voltage, Current, Temperature | 24 V $\overline{\text{DC}}$ sensors (2-wire and 3-wire) 15...30 V $\overline{\text{DC}}$ incremental encoders (60 kHz) | $\overline{\text{DC}}$ 24 V \sim 120 V | - 10...+ 10 VDC, 0...+ 10 VDC / 0...20 mA, 4...20 mA temperature probe : TC (J, K, R, S, B, T, N, E, C, L) RTC (Ni100, Ni1000, PT100, PT1000) | | |
| Outputs | Number (depending on model) | 8 to 32 outputs | 1 to 2 outputs | 2 channels with 2 outputs | 8 to 32 outputs | 1 to 4 outputs | |
| | | Type (depending on model) | 24 V $\overline{\text{DC}}$ transistor, relay | 0...10 V, \pm 10 V, 4...20 mA | 24 V $\overline{\text{DC}}$ transistor | 24 V $\overline{\text{DC}}$ transistor, relay | - 10...+ 10 VDC, 0...+ 10 VDC / 0...20 mA, 4...20 mA |

| Range | Modicon TM2 | | | Modicon TM3 | | | |
|-------|-----------------|----------------|----------------|-----------------|----------------|---------------|--|
| | Digital modules | Analog modules | Expert modules | Digital modules | Analog modules | Expert module | Functional Safety modules (Powered by Preventa technology) |
| Page | 3/6 | 3/14 | 3/18 | 3/22 | 3/28 | 3/30 | 3/32 |

(1) Modicon **TM3** transmitter/receiver modules, see page 3/20.
Nota: distributed I/O configurations, see the following pages

| Local and/or remote I/O (IP 20) | | | | Remote I/O expansion bus (IP 67) | |
|---|--------|----------------|--------|---|--------|
| <ul style="list-style-type: none"> Modicon M258 logic controller Modicon LMC058 motion controller Modicon LMC078 motion controller | | | | <ul style="list-style-type: none"> Modicon M258 logic controller Modicon LMC058 motion controller Modicon LMC078 motion controller | |
| Digital | Analog | Digital/analog | Expert | Digital | Analog |
| <p>Modicon TM5 transmitter/receiver: For use with remote I/O (2)</p> <p>TM5 expansion bus</p> <p>TM7 expansion bus</p> | | | | | |
| - | | | | | |
| - | | | | | |



| Local and/or remote I/O (IP 20) | | Remote I/O expansion bus (IP 67) | |
|---|---|--|--|
| 2 to 12 inputs | 2 to 6 inputs | Digital: 12 to 14 inputs Analog: 4 inputs | 1 or 2 channels with 2 inputs |
| 24 V $\overline{\text{DC}}$ 100/120 V \sim , 100/240 V \sim | Voltage, Current, Temperature Strain gauge | Digital: 24 V $\overline{\text{DC}}$ Analog: Voltage, Current | 5 V $\overline{\text{DC}}$, 24 V $\overline{\text{DC}}$ (from 50 kHz to 1 MHz) |
| 2 to 12 outputs | 2 to 4 outputs | Digital: 6 to 18 outputs Analog: 2 outputs | 8 to 16 outputs |
| 24 V $\overline{\text{DC}}$ 30/230 V \sim , 100/240 V \sim | - 10...+ 10 V, 0...20 mA | Digital: 24 V $\overline{\text{DC}}$ Analog: Voltage/Current | 24 V $\overline{\text{DC}}$ Transistor/Source |
| | | | - 10...+ 10 V, 0...20 mA |

| Modicon TM5 | | | | Modicon TM7 | |
|-----------------|----------------|-----------------|----------------|----------------|---------------|
| Digital modules | Analog modules | Compacts blocks | Expert modules | Digital blocks | Analog blocks |
| Page | 3/42 | 3/50 | 3/38 | 3/54 | 3/64 |

(2) Modicon **TM5** transmitter/receiver modules, see page 3/60.

Expansion modules

Distributed I/O expansion modules

| | |
|----------------------|---|
| Applications | Optimum distributed I/O (IP 20) |
| Compatibility | <ul style="list-style-type: none"> ■ Modicon M238 logic controller ■ XBTGC HMI controller, XBTGT/GK with monitoring function ■ Altivar IM C drive controller |



| | |
|---|--|
| Available buses and networks | <ul style="list-style-type: none"> ■ Ethernet Modbus TCP/IP ■ CANopen bus ■ Modbus serial link (RS 485) |
| Configuration with I/O expansion modules | <p>Modicon TM2:</p> <ul style="list-style-type: none"> <input type="checkbox"/> Digital I/O modules <input type="checkbox"/> Analog I/O modules <input type="checkbox"/> Expert modules <input type="checkbox"/> Common distribution modules |
| Capacity | <p>For 1 Modicon OTB interface module: 7 Modicon TM2 modules max. Including:</p> <ul style="list-style-type: none"> <input type="checkbox"/> Digital I/O modules: <ul style="list-style-type: none"> - 132 I/O max. with modules with screw terminals - 188 I/O max. with modules with spring terminals - 244 I/O max. with modules with HE10 connector <input type="checkbox"/> Analog I/O modules with screw terminals: up to 7 x 8 inputs, or 7 x 2 outputs, or 7 x (4I/2O) <input type="checkbox"/> Expert modules <input type="checkbox"/> Common distribution module |

| | | |
|-----------------------|--------------------------------------|---|
| Integrated I/O | Number and type (depending on model) | <p>12 x 24 V $\overline{\text{---}}$ digital inputs 2 x 24 V $\overline{\text{---}}$ solid state outputs 6 x 30 V $\overline{\text{---}}$/240 V \sim relay outputs 2 channels: 5 kHz/20 kHz 2 PWM function channels</p> |
|-----------------------|--------------------------------------|---|

| | |
|--------------|--------------------------------------|
| Range | Modicon OTB interface modules |
|--------------|--------------------------------------|

| | |
|--------------|------|
| Pages | 4/18 |
|--------------|------|

| | |
|---|---|
| Performance distributed I/O (IP 20) | Performance distributed I/O (IP 67) |
| <ul style="list-style-type: none"> ■ Modicon M258 logic controller ■ Modicon LMC058 motion controller ■ Modicon LMC078 motion controller | <ul style="list-style-type: none"> ■ Modicon M258 logic controller ■ Modicon LMC058 motion controller ■ Modicon LMC078 motion controller |



| | |
|---|---|
| Available buses and networks | <ul style="list-style-type: none"> ■ CANopen bus |
| Configuration with I/O expansion modules | <p>Modicon TM5 modules and/or Modicon TM7 blocks:</p> <ul style="list-style-type: none"> <input type="checkbox"/> Digital I/O modules <input type="checkbox"/> Analog I/O modules <input type="checkbox"/> Common distribution modules (TM5 only) |
| Capacity | <p>For 1 Modicon TM5 interface module: 40 TM5/TM7 modules max. Including:</p> <ul style="list-style-type: none"> <input type="checkbox"/> Digital I/O modules: 240 inputs and 240 outputs max. <input type="checkbox"/> Analog I/O modules: 20 inputs and 20 outputs <p>Maximum distance from the expansion bus (TM5 or TM7): 2500 m. Maximum distance between 2 islands of TM5 modules: 100 m. Maximum distance between 2 TM7 blocks: 100 m. Maximum distance between 1 island of TM5 modules and 1 TM7 block: 100 m.</p> |

| | | |
|-----------------------|--------------------------------------|---|
| Integrated I/O | Number and type (depending on model) | <p>8 to 16 digital channels that can be configured as inputs (24 V $\overline{\text{---}}$) or outputs (24 V $\overline{\text{---}}$)</p> |
|-----------------------|--------------------------------------|---|

| | | |
|--------------|---|---|
| Range | Modicon TM5 CANopen interface module | Modicon TM7 CANopen interface blocks |
|--------------|---|---|

| | | |
|--------------|------|------|
| Pages | 4/24 | 4/28 |
|--------------|------|------|

| | | | | |
|-----------------|---|--|---|---|
| Applications | Type of expansion modules | Digital inputs with removable screw terminal block | | |
| | Compatibility | <ul style="list-style-type: none"> - Modicon M238 logic base controllers - Twido compact and modular controllers - Magelis HMI Controller XBTGC - Modicon OTB I/O distributed Interfaces - Modicon M221 logic controllers - Modicon M241 logic controllers - Modicon M251 logic controllers | | |
| Number and type | |  |  |  |
| | | 8 $\overline{\text{---}}$ 24 V inputs | 8 \sim 120 V inputs | 16 $\overline{\text{---}}$ 24 V inputs |
| | Connection | By removable screw terminal block | | |
| Inputs | Voltage range | $\overline{\text{---}}$ 20.4...28.8 V | \sim 85...132 V | $\overline{\text{---}}$ 20.4...28.8 V |
| | Input current | 7 mA per channel | 7.5 mA per channel | 7 mA per channel |
| | Input logic | Sink/source (1) | – | Sink/source (1) |
| | Commons | 1 x 8 channels | 1 x 8 channels | 1 x 16 channels |
| | Response time <input type="checkbox"/> Off-on <input type="checkbox"/> On-off | 4 ms 4 ms | 25 ms 30 ms | 4 ms 4 ms |
| Outputs | Output types | – | | |
| | Voltage range | – | | |
| | Commons | – | | |
| | Output current <input type="checkbox"/> Per output <input type="checkbox"/> Per group of channels | – | | |
| | Isolation | Between channels | None | |
| | Between channels and internal logic | 500 V rms \sim for 1 min | 1500 V rms \sim for 1 min | 500 V rms \sim for 1 min |
| I/O module type | | TM2DDI8DT | TM2DAI8DT | TM2DDI16DT |
| Pages | 3/12 (1) Sink input: positive logic, source input: negative logic. | | | |

| | | | | | | | |
|-----------------|---|--|---|--|---|--|--|
| Applications | Type of expansion modules | Digital inputs with HE10 connector | | Digital I/O with removable screw terminal block | | Digital I/O with non-removable spring terminal block | |
| | Compatibility | <ul style="list-style-type: none"> - Modicon M238 logic base controllers - Twido compact and modular controllers - Magelis HMI Controller XBTGC - Modicon OTB I/O distributed Interfaces - Modicon M221 logic controllers - Modicon M241 logic controllers - Modicon M251 logic controllers | | | | | |
| Number and type | |  |  |  |  | | |
| | | 16 $\overline{\text{---}}$ 24 V inputs | 32 $\overline{\text{---}}$ 24 V inputs | 4 $\overline{\text{---}}$ 24 V inputs/4 relay outputs | 16 $\overline{\text{---}}$ 24 V inputs/8 relay outputs | | |
| | Connection | By HE10 connector Allows use of the Modicon Telefast ABE 7 pre-wired system | | By removable screw terminal block | | By non-removable spring terminal block | |
| Inputs | Voltage range | $\overline{\text{---}}$ 20.4...28.8 V | | $\overline{\text{---}}$ 20.4...28.8 V | | $\overline{\text{---}}$ 20.4...28.8 V | |
| | Input current | 5 mA per channel | | 7 mA per channel | | 7 mA per channel | |
| | Input logic | Sink/source (1) | | Sink/source (1) | | Sink/source (1) | |
| | Commons | 1 x 16 channels | 2 x 16 channels | 1 x 4 channels | 2 x 4 channels | 1 x 16 channels | |
| | Response time <input type="checkbox"/> Off-on <input type="checkbox"/> On-off | 4 ms 4 ms | | 4 ms 4 ms | | 4 ms 4 ms | |
| Outputs | Output types | – | | 1 N/O contact | | – | |
| | Voltage range | – | | \sim 240 V, $\overline{\text{---}}$ 30V | | – | |
| | Commons | – | | 1 x 4 channels | | 2 x 4 channels | |
| | Output current <input type="checkbox"/> Per output <input type="checkbox"/> Per group of channels | – | | 2 A (lth) 7 A (lth) | | – | |
| | Isolation | Between channels | None | | None between input channels, none between output channels | | |
| | Between channels and internal logic | 500 V rms \sim for 1 min | | Between input group and output groups: 1500 V rms \sim for 1 min Between output groups: 1500 V rms \sim for 1 min Between input channels and internal logic: 500 V rms \sim for 1 min Between output channels and internal logic: 2300 V rms \sim for 1 min | | | |
| I/O module type | | TM2DDI16DK | TM2DDI32DK | TM2DMM8DRT | TM2DMM24DRF | | |
| Pages | 3/12 | | | | | | |

Expansion modules

Modicon TM2 Digital modules

| | | | | | |
|---------------------|---------------------------|--|--|--|--|
| Applications | Type of expansion modules | 8/16 outputs with removable screw terminal block | | | |
| | Compatibility | <ul style="list-style-type: none"> - Modicon M238 logic base controllers - Twido compact and modular controllers - Magelis HMI Controller XBTGC - Modicon OTB I/O distributed Interfaces - Modicon M221 logic controllers - Modicon M241 logic controllers - Modicon M251 logic controllers | | | |



| | | | |
|-------------|-------------------------------|-----------------|------------------|
| Type | 8 --- 24 V transistor outputs | 8 relay outputs | 16 relay outputs |
|-------------|-------------------------------|-----------------|------------------|

| | | | |
|-------------------|-----------------------------------|--|--|
| Connection | By removable screw terminal block | | |
|-------------------|-----------------------------------|--|--|

| | | | | | | |
|---|---|----------------------------------|---------------|--------------------------|----------------|--|
| Outputs | Output types | Transistor | | Relay with 1 N/O contact | | |
| | Voltage range | --- 20.4...28.8 V | | ~ 240 V, --- 30 V | | |
| | Logic (1) | Sink | Source | - | | |
| | Commons | 1 x 8 channels | | 2 x 4 channels | 2 x 8 channels | |
| | Output current | 0.3 A max. | 0.5 A max. | 2 A max. | | |
| | □ Per output □ Per group of channels | 3 A at 28.8 V | 4 A at 28.8 V | 7 A max. | 8 A max. | |
| Protection against overload and short-circuit | - | Yes, with automatic reactivation | | - | | |

| | | | | | |
|------------------|-------------------------------------|-----------------------|--|------------------------|--|
| Isolation | Between channels | None | | None | |
| | Between group of channels | - | | 1500 V rms for 1 min | |
| | Between channels and internal logic | 500 V rms ~ for 1 min | | 2300 V rms ~ for 1 min | |

| | | | | |
|---------------------------|------------------|------------------|------------------|-------------------|
| Output module type | TM2DDO8UT | TM2DDO8TT | TM2DRA8RT | TM2DRA16RT |
|---------------------------|------------------|------------------|------------------|-------------------|

| | |
|--------------|------|
| Pages | 3/12 |
|--------------|------|

(1) Source output: positive logic, sink output: negative logic.

| | | | |
|--|--|--|--|
| 16/32 outputs with HE 10 connectors | | | |
| <ul style="list-style-type: none"> - Modicon M238 logic base controllers - Twido compact and modular controllers - Magelis HMI Controller XBTGC - Modicon OTB I/O distributed Interfaces - Modicon M221 logic controllers - Modicon M241 logic controllers - Modicon M251 logic controllers | | | |



| | | | |
|--------------------------------|--------------------------------|--------------------------------|--------------------------------|
| 16 --- 24 V transistor outputs | 16 --- 24 V transistor outputs | 32 --- 24 V transistor outputs | 32 --- 24 V transistor outputs |
|--------------------------------|--------------------------------|--------------------------------|--------------------------------|

| | | | |
|-------------------|--|-------------------|--|
| By HE10 connector | By HE10 connector Allows use of the Modicon Telefast ABE 7 pre-wired system | By HE10 connector | By HE10 connector Allows use of the Modicon Telefast ABE 7 pre-wired system |
|-------------------|--|-------------------|--|

| | | | | |
|----------------|----------------------------------|---------------|----------------------------------|---------------|
| Outputs | Transistors | | | |
| | --- 20.4...28.8 V | | | |
| | Sink | Source | Sink | Source |
| | 1 x 16 channels | | 2 x 16 channels | |
| | 0.1 A max. | 0.4 A max. | 0.1 A max. | 0.4 A max. |
| | 1 A at 28.8 V | 2 A at 28.8 V | 1 A at 28.8 V | 2 A at 28.8 V |
| - | Yes, with automatic reactivation | - | Yes, with automatic reactivation | |

| | | | |
|-----------------------|------|--|--|
| None | None | | |
| - | - | | |
| 500 V rms ~ for 1 min | - | | |

| | | | |
|-------------------|-------------------|-------------------|-------------------|
| TM2DDO16UK | TM2DDO16TK | TM2DDO32UK | TM2DDO32TK |
|-------------------|-------------------|-------------------|-------------------|

| |
|------|
| 3/12 |
|------|

Presentation

The offer digital I/O expansion modules includes input modules, output modules and mixed input/output modules. With the 15 I/O modules offered, in addition to the I/O integrated in 24 and 40 I/O compact base controllers and modular base controllers, configurations can be adapted to suit application requirements, so optimising costs.

The following digital I/O modules are available:

- Four 24 V digital input modules comprising an 8, 16 and a 32-channel module, equipped with either removable screw terminal blocks or HE 10 connector, depending on the model. These modules can be either “sink or source” .
- One ~ 120 V digital input module, 8 channels, equipped with a removable screw terminal block.
- Eight digital output modules comprising two output modules with 8 and 16 relay outputs, output modules with 8, 16 or 32-channel “sink” or “source” transistor outputs, equipped with either removable screw terminal blocks or HE 10 connector, depending on the model.
- Two mixed digital input and output modules, comprising one 4-channel input/4-channel relay output module with removable screw terminal block and one 16-channel input/8-channel relay output module with non-removable spring terminal block.

The narrow width of these I/O modules (17.5 mm/0.69 in., 23.5 mm/0.93 in., 29.7 mm/1.17 in. or 39.1 mm/1.54 in.) makes it possible to build Modicon M238, Twido or Modicon OTB configurations of up to 248 I/O with a minimal overall size of L 364.9 mm/14.37 in. x H 90 mm/3.54 in. x D 81.3 mm/3.20 in.

These digital I/O modules are mounted as standard on symmetrical rails to the right of the controller.

The maximum number of digital and/or analogue I/O modules which may be mounted depends on the type of base controller:

| Base controller type | Twido compact and modular | | | | | | Modicon M238 | Modicon M221 and M221 Book | | Modicon M241 Modicon M251 | Magelis HMI controller | | Modicon OTB interface |
|----------------------|-------------------------------------|-----------------|-----------------|----------------|-----------------|----------------|-----------------|----------------------------|--|------------------------------|------------------------|----------------|-----------------------|
| | TWDLCA 10DRF, TWDLCA 16DRF | TWDLCA 24DRF | TWDLCA 40DRF | TWDLCA 20DK | TWDLCA 20DRT | TWDLCA 40DK | TM238 L..... | TM221C16●, TM221CE16● | TM221M16●, TM221ME16●, TM221●●24●, TM221M●32TK, TM221●●40● | TM241C●●●●● TM251MES● | XBT GC1100● | XBT GC2●●0● | OTB1●0 DM9LP |
| Number of modules | 0 | 4 | 7 | 4 | 7 | 7 | 7 | 7 | 7 | 7 | 2 | 3 | 7 |

The digital I/O modules are electrically isolated with the use of a photocoupler between the internal electronic circuit and the input/output channels.

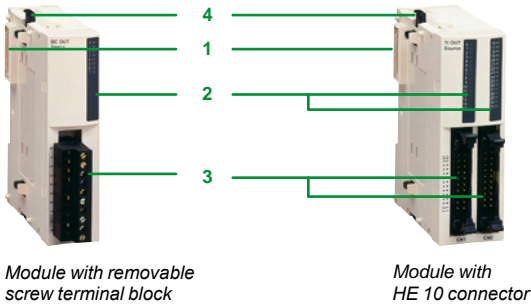

Description

Digital I/O expansion modules comprise:

- 1 An extension connector for electrical connection to the previous module (1).
- 2 One or two blocks for displaying the channels and module diagnostics.
- 3 One or two connection components of varying type, depending on the model:
 - removable screw terminal block (1 or 2) for modules whose reference ends in **T**,
 - HE 10 connector (1 or 2) for modules whose reference ends in **K**,
 - non-removable spring terminal block for module **TM2DMM24DRF**.
- 4 Latching mechanism for attachment to the previous module.

These modules are mounted on a symmetrical \perp rail. The **TWDXMT5** mounting kit can be used for plate or panel mounting. For modules with removable screw terminal block, the terminal blocks are supplied with the module.

The **OTB9ZZ61JP** supply common distribution module (2 isolated groups of 10 terminals) simplifies the wiring of supply commons of sensors or actuators via 2 removable screw terminal blocks.

(1) A connector on the right-hand side makes continuity of the electrical link with the next I/O module.

3



TM2DDI8DT



TM2DDI32DK



TM2DDO8●T/DRA8RT



TM2DDO16●K



TM2DDO32●K



TM2DRA16RT



TM2DMM8DRT



TM2DMM24DRF

References

Digital input modules

| Input voltage | Nb of channels | Nb of common points | Connection | Reference | Weight kg/lb |
|--------------------|----------------|---------------------|---|-----------------------|--------------|
| ≡ 24 V sink/source | 8 | 1 | Removable screw terminal block (supplied) | TM2DDI8DT | 0.085/0.187 |
| | 16 | 1 | Removable screw terminal block (supplied) | TM2DDI16DT | 0.100/0.220 |
| | | | HE 10 connector | TM2DDI16DK (1) | 0.065/0.143 |
| | 32 | 2 | HE 10 connector | TM2DDI32DK (1) | 0.100/0.220 |
| ~ 120 V | 8 | 1 | Removable screw terminal block (supplied) | TM2DAI8DT | 0.081/0.179 |

Digital output modules

| Type de sortie | Nb of channels | Nb of common points | Connection | Reference | Weight kg/lb |
|--------------------------------|------------------|---------------------|---|-----------------------|--------------|
| Transistors ≡ 24 V | 8, sink 0.3 A | 1 | Removable screw terminal block (supplied) | TM2DDO8UT | 0.085/0.187 |
| | 8, source 0.5 A | 1 | Removable screw terminal block (supplied) | TM2DDO8TT | 0.085/0.187 |
| Transistors ≡ 24 V | 16, sink 0.1 A | 1 | HE 10 connector | TM2DDO16UK | 0.070/0.154 |
| | 16, source 0.4 A | 1 | HE 10 connector | TM2DDO16TK (1) | 0.070/0.154 |
| | 32, sink 0.1 A | 2 | HE 10 connector | TM2DDO32UK | 0.105/0.231 |
| | 32, source 0.4 A | 2 | HE 10 connector | TM2DDO32TK (1) | 0.105/0.231 |
| Relay 2 A (lth) ~ 230 V/≡ 30 V | 8 (N/O contact) | 2 | Removable screw terminal block (supplied) | TM2DRA8RT | 0.110/0.243 |
| | 16 (N/O contact) | 2 | Removable screw terminal block (supplied) | TM2DRA16RT | 0.145/0.320 |

Digital mixed input/output modules

| Nb of I/O | Nb, type of input | Nb, type of output | Nb of common points | Connection | Reference | Weight kg/lb |
|-----------|--------------------------|------------------------------------|--|---|--------------------|--------------|
| 8 | 4 I, ≡ 24 V sink/source | 4 O, relay (N/O contact) 2 A (lth) | Inputs: 1 common Outputs: 1 common | Removable screw terminal block (supplied) | TM2DMM8DRT | 0.095/0.209 |
| 24 | 16 I, ≡ 24 V sink/source | 8 O, relay (N/O contact) 2 A (lth) | Inputs: 1 common Outputs: 2 commons | Non-removable spring terminal block | TM2DMM24DRF | 0.140/0.309 |

(1) Module that allows use of the Modicon Telefast ABE 7 pre-wired system.



OTB9ZZ61JP

References

Separate components

| Description | Application | Reference | Weight kg/ lb |
|--|---|-------------------|---------------------|
| Mounting kit Sold in lots of 5 | For plate or panel mounting of the digital modules. | TWDXMT5 | 0.065/ 0.143 |
| Commun distribution module | For distribution of supply commons. 8 A max. Connection on 2 removable screw terminal blocks | OTB9ZZ61JP | 0.100/ 0.220 |

| Description | Number of ways | Reference | Weight kg/ lb |
|---|----------------|-------------------|---------------------|
| HE 10 female connectors Sold in lots of 5 | 20 | TWDFCN2K20 | – |
| | 26 | TWDFCN2K26 | – |

Pre-formed cables for digital I/O modules with HE 10 connectors

| Description | For use with Twido | Gauge C.s.a. | Cable length m/ft | Reference | Weight kg/ lb |
|---|-----------------------------------|---------------------------------|-------------------|------------------|---------------------|
| Pre-formed cables 1 pre-formed cable: one end fitted with HE 10 connector, one end with free wires | I/O expansions TM2DDI | AWG 22 0.035 mm ² | 3/ 9.84 | TWDFCW30K | 0.405/ 0.892 |
| | 16DK/32DK TM2 DDO 16●K/32●K | AWG 22 0.035 mm ² | 5/ 16.40 | TWDFCW50K | 0.670/ 1.477 |

Pre-formed connecting cables (1)

| Description | Association | Jauge Section | Longueur cordon | Reference | Weight kg/ lb |
|---|-------------------|---------------------------------|-----------------|---------------------|---------------------|
| Digital input pre-formed cables, 1 pre-formed cable: one end with 20-way HE 10 connector on TM2 side, one end with 20-way HE 10 connector on sensor side | Inputs TM2DDI | AWG 28 0.080 mm ² | 1/ 3.28 | ABFTE20EP100 | 0.080/ 0.176 |
| | 16DK/32DK | AWG 28 0.080 mm ² | 2/ 6.56 | ABFTE20EP200 | 0.140/ 0.309 |
| | | AWG 28 0.080 mm ² | 3/ 9.84 | ABFTE20EP300 | 0.210/ 0.463 |
| Digital output pre-formed cables 1 pre-formed cable: one end with 20-way HE 10 connector on TM2 side, one end with 20-way HE 10 connector on preactuator side | Outputs TM2DDO | AWG 28 0.080 mm ² | 1/ 3.28 | ABFTE20SP100 | 0.080/ 0.176 |
| | 16TK/32TK | AWG 28 0.080 mm ² | 2/ 6.56 | ABFTE20SP200 | 0.140/ 0.309 |
| | | AWG 28 0.080 mm ² | 3/ 9.84 | ABFTE20SP300 | 0.210/ 0.463 |

(1) Cables for applications with Twido controllers.

| Applications | Type of expansion modules | Analog inputs | | | |
|--------------|---------------------------|---|--|--|--|
| | Compatibility | <ul style="list-style-type: none"> - Modicon M238 logic controllers - Twido controllers - Magelis HMI controller - Modicon OTB I/O distributed Interfaces - Modicon M221 logic controllers - Modicon M241 logic controllers - Modicon M251 logic controllers | | | |



| Type | 2 inputs | 4 inputs | 8 inputs |
|--------|-----------------|---------------------|--------------------------------------|
| Nature | Voltage/current | Thermocouple inputs | Voltage/current Temperature probe |

| Connection | Removable screw terminal block | | | |
|------------|--------------------------------|--|--|--|
|------------|--------------------------------|--|--|--|

| Inputs | Range | 0...10 V 4...20 mA (non differential) | Thermocouple type J, K and T (differential) (1) | <input type="checkbox"/> 0...10 V or 0...20 mA (Transfer time: 160 ms per channel) <input type="checkbox"/> Temperature probe 2, 3 or 4-wire: - Pt 100/1000: - 200...600 °C, - Ni 100/1000: - 50...150 °C (non differential) (Transfer time: 320 ms per channel + 1 controller cycle time) | 0...10 V 0...20 mA (non differential) |
|--------|--------------------|---|---|--|--|
| | Resolution | 12 bits (4096 points) | 12 bits (4096 points) | 12 bits (4096 points) | 10 bits (1024 points) |
| | Acquisition period | 10 ms per channel + 1 controller cycle time | 200 ms per channel + 1 controller cycle time | <input type="checkbox"/> 160 ms per channel <input type="checkbox"/> 320 ms per channel + 1 controller cycle time | 160 ms per channel + 1 controller cycle time |

| Outputs | Range | - |
|---------|---------------|---|
| | Resolution | - |
| | Transfer time | - |

| External supply | Nominal voltage | ~ 24 V |
|-----------------|-----------------|-----------------|
| | Limit values | ~ 20.4...28.8 V |

| Isolation | Between channels | Non isolated |
|-----------|-------------------------------------|---|
| | Between channels and sensor supply | ~ 500 V rms |
| | Between channels and internal logic | ~ 500 V rms ~ 2500 V rms ~ 2500 V rms |

| Analog I/O module type | TM2AMI2HT | TM2AMI2LT | TM2AMI4LT | TM2AMI8HT |
|------------------------|-----------|-----------|-----------|-----------|
|------------------------|-----------|-----------|-----------|-----------|

| Pages | 3/17 |
|-------|------|
|-------|------|

(1) ⚠ Analog inputs module TM2AMI2LT do not detect the absence/presence of PC R3 5984 cable.
 (2) Connection by a removable screw terminal block.
 (3) Connection by a RJ11 connector.
 (4) ⚠ When cable is disconnected, analog value is max.

| Analog inputs (continued) | | Analog outputs | | Analog I/O | | |
|---|--|----------------|--|------------|--|--|
| <ul style="list-style-type: none"> - Modicon M238 logic controllers - Twido controllers - Magelis HMI controller - Modicon OTB I/O distributed Interfaces - Modicon M221 logic controllers - Modicon M241 logic controllers - Modicon M251 logic controllers | | | | | | |



| Type | 8 inputs | 1 output | 2 outputs | 2 inputs/1 output | 4 inputs/2 outputs |
|--------|--------------------------|-----------------|-----------|-------------------|---|
| Nature | Temperature probe inputs | Voltage/current | Voltage | Voltage/current | Thermocouple/temperature probe inputs Voltage/current output |

| Connection | Removable screw terminal block | Removable screw terminal block and RJ11 connectors | Removable screw terminal block | | |
|------------|--------------------------------|--|--------------------------------|--|--|
|------------|--------------------------------|--|--------------------------------|--|--|

| Inputs | Range | NTC probe (non differential) | PTC probe ⚠ Threshold detection (high and low) (non dif.) | Temperature probe 2 or 3-wire Pt100: - 200...600 °C Pt1000: - 50...200 °C (non differential) | - | 0...10 V 4...20 mA (non differential) | Thermocouple type J, K and T Temperature probe 2 or 3-wire Pt100: - 100...500 °C (differential) (4) | 0...10 V 4...20 mA (non differential) |
|--------|--------------------|--|---|--|---|---|--|---|
| | Resolution | 10 bits (1024 pts) | 1 < range 2 = range 4 > range | 12 bits (4096 points) | - | 12 bits or 11 bits + sign (4096 points) | 12 bits (4096 points) | |
| | Acquisition period | 160 ms per channel + 1 controller cycle time | | 320 ms per channel (1280 ms maxi.) + 1 controller cycle time | - | 10 ms per channel + 1 controller cycle time | 50 ms per channel + 1 controller cycle time | 16 ms (fast) / 64 ms (normal) per channel + 1 controller cycle time |

| Outputs | Range | - | 0...10 V 4...20 mA | ± 10 V | 0...10 V 4...20 mA |
|---------|---------------|---|---------------------------------|--------------------------------|---------------------------------|
| | Resolution | - | 12 bits (4096 points) | 11 bits (2048 points) + sign | 12 bits (4096 points) |
| | Transfer time | - | 10 ms + 1 controller cycle time | 2 ms + 1 controller cycle time | 20 ms + 1 controller cycle time |

| External supply | Nominal voltage | ~ 24 V | ~ 19.2...30 V | ~ 24 V |
|-----------------|-----------------|-----------------|---------------|---------------|
| | Limit values | ~ 20.4...28.8 V | ~ 19.2...30 V | ~ 19.2...30 V |

| Isolation | Between channels | Non isolated | ~ 500 V rms | ~ 500 V rms | Non isolated | ~ 500 V rms | ~ 800 V rms |
|-----------|-------------------------------------|--------------|-------------|-------------|--------------|-------------|--------------|
| | Between channels and sensor supply | ~ 2500 V rms | ~ 500 V rms | ~ 500 V rms | ~ 2500 V rms | ~ 500 V rms | ~ 1500 V rms |
| | Between channels and internal logic | ~ 2500 V rms | ~ 500 V rms | ~ 500 V rms | ~ 2500 V rms | ~ 500 V rms | ~ 1500 V rms |

| Analog I/O module type | TM2ARI8HT | TM2ARI8LT (2) TM2ARI8LRJ (3) | TM2AMO1HT | TM2AVO2HT | TM2AMM3HT | TM2ALM3LT | TM2AMM6HT |
|------------------------|-----------|---------------------------------|-----------|-----------|-----------|-----------|-----------|
|------------------------|-----------|---------------------------------|-----------|-----------|-----------|-----------|-----------|

| Pages | 3/17 |
|-------|------|
|-------|------|

(1) ⚠ Analog inputs module TM2AMI2LT do not detect the absence/presence of PC R3 5984 cable.
 (2) Connection by a removable screw terminal block.
 (3) Connection by a RJ11 connector.
 (4) ⚠ When cable is disconnected, analog value is max.

Presentation

Analog I/O expansion modules enable the acquisition of various analog values encountered in industrial applications. Analog output modules are used to control the preactuators in devices such as variable speed drives, valves and applications that require process control. The output current or voltage is proportional to the numerical value defined by the user program. When the controller stops, the outputs can be configured with fallback (reset to the lowest scale value or hold the last value received). This function, when set to 'hold', is useful when debugging the application.

The following 10 analog I/O modules are available:

- One module with 2 inputs: 0...10 V, 4...20 mA
- One module with 2 inputs for type J, K and T thermocouples
- One module with 4 inputs: 0...10 V, 0...20 mA, Pt 100/1000 range - 200...600°C, Ni100/1000 range - 50...150°C
- Two modules with 8 temperature probe inputs: Pt100 range - 200...600°C and Pt1000 range - 50...200°C (with RJ11 connectors or removable screw terminal block)
- One module with 8 inputs: 0...10 V, 0...20 mA
- One module with 8 inputs: PTC/NTC (1)
- One module with 1 output: 0...10 V, 4...20 mA
- One module with 2 outputs: ± 10 V
- One mixed module with 2 inputs (0...10 V, 4...20 mA) and 1 output (0...10 V, 4...20 mA)
- One mixed module with 2 thermocouple (type J, K and T) or temperature probe inputs and 1 output 0...10 V, 4...20 mA
- One mixed module with 4 inputs (0...10 V, 4...20 mA) and 2 outputs (0...10 V, 4...20 mA)

Analog expansion modules offer a resolution of 10 bits, 11 bits + sign and 12 bits, with connection by removable screw terminal block. An external 24 V $\bar{\text{---}}$ power supply is required for each analog module.

These analog I/O expansion modules are mounted on symmetrical $\bar{\text{---}}$ rails to the right of base controller below. The maximum number of I/O and/or analog modules which may be mounted depends on the type of base controller:

| Base controller type | Twido compact and modular | | | | | | Modicon M238 | Modicon M221 and M221 Book | | | Modicon M241 Modicon M251 | Magelis HMI controller | | Modicon OTB interface |
|----------------------|----------------------------|--------------|--------------|-------------|--------------|-------------|--------------|----------------------------|---|-----------------------|---------------------------|------------------------|-------------|-----------------------|
| | TWDLCA 10DRF, TWDLCA 16DRF | TWDLCA 24DRF | TWDLCA 40DRF | TWDLCA 20DK | TWDLCA 20DRT | TWDLCA 40DK | TM238 L..... | TM221C16, TM221CE16 | TM221M16, TM221ME16, TM221M24, TM221M32TK, TM221M40 | TM241C....., TM251MES | XBT GC1100 | XBT GC2...0 | OTB10 DM9LP | |
| Number of modules | 0 | 4 | 7 | 4 | 7 | 7 | 7 | 7 | 7 | 7 | 2 | 3 | 7 | |

Analog I/O modules are electrically isolated with the use of a photocoupler between the internal electronic circuit and the input/output channels.

Description

Analog I/O modules comprise:

- 1 An extension connector for electrical connection to the adjacent module (2)
 - 2 A PWR display block
 - 3 One (or two, depending on model) removable screw terminal block(s) for connecting the 24 V $\bar{\text{---}}$ external power supply, the sensors and the preactuators
 - 4 A latching mechanism for attachment to the adjacent module
- For modules with 8 temperature probe inputs:
- 5 8 RJ11 connectors. A version of this module is available with 2 removable screw terminal blocks (2 x 13 terminals)
 - 6 A screw terminal for connecting the functional ground (FG)
 - 7 A removable screw terminal block for connecting the 24 V $\bar{\text{---}}$ power supply

The **TM2XMTGB** ground connection plate **8** simplifies connection of the analog sensor and actuator cable shielding. Connect this shielding to the device's functional ground (FG).

These modules are mounted on a symmetrical $\bar{\text{---}}$ rail. Mounting kit **TWDXMT5** can be used for plate or panel mounting.

(1) With PTC probe, threshold detection inputs (high and low).

(2) A connector on the right-hand side panel makes the continuity of the electrical link with the adjacent I/O module.

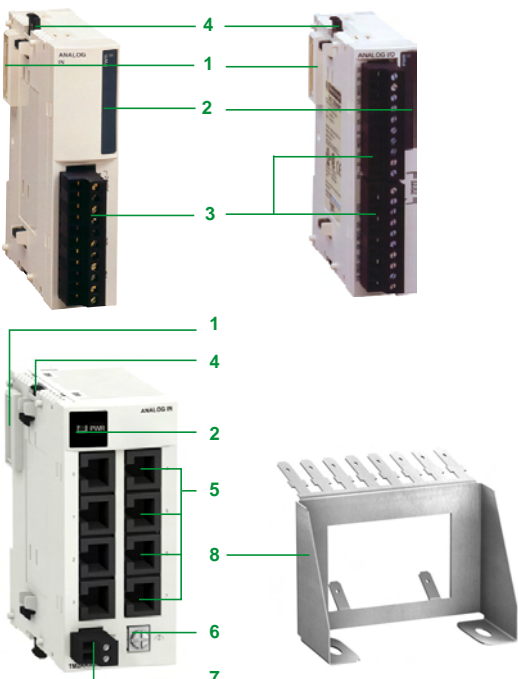



TM2AMI2HT



TM2AMI2LT



TM2ARI8LRJ



TM2ARI8LT



TM2ALMLT



TM2AMM6HT

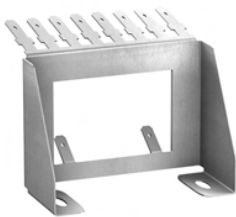

TM2XMTGB



TM200RSRCEMC

References

Analog input modules

| Channel type | Input range | Output range | Resolution | Connection by | Reference | Weight kg/ lb |
|--------------|--------------------------------------|--------------|---|---|-------------------|---------------------|
| 2 inputs | 0...10 V 4...20 mA | – | 12 bits | Removable screw terminal block (supplied) | TM2AMI2HT | 0.085/ 0.187 |
| | Thermocouple K, J, T | – | 12 bits | Removable screw terminal block (supplied) | TM2AMI2LT | 0.085/ 0.187 |
| 4 inputs | 0...10 V 0...20 mA Temperature | – | 12 bits | Removable screw terminal block (supplied) | TM2AMI4LT | 0.085/ 0.187 |
| 8 inputs | 0...10 V 0...20 mA | – | 10 bits | Removable screw terminal block (supplied) | TM2AMI8HT | 0.085/ 0.187 |
| | Pt 100 Pt 1000 | – | 12 bits | RJ11 connector | TM2ARI8LRJ | 0.190/ 0.419 |
| | PTC/NTC | – | 10 bits for NTC 2-threshold detection with PTC | Removable screw terminal block (supplied) | TM2ARI8LT | 0.190/ 0.419 |
| | | | | Removable screw terminal block (supplied) | TM2ARI8HT | 0.085/ 0.187 |

Analog output modules

| | | | | | | |
|-----------|---|-----------------------|----------------|---|------------------|-----------------|
| 1 output | – | 0...10 V 4...20 mA | 12 bits | Removable screw terminal block (supplied) | TM2AMO1HT | 0.085/ 0.187 |
| 2 outputs | – | ± 10 V | 11 bits + sign | Removable screw terminal block (supplied) | TM2AVO2HT | 0.085/ 0.187 |

Analog I/O modules

| | | | | | | |
|---------------------------|--|-----------------------|---------|---|------------------|-----------------|
| 2 inputs and 1 output | 0...10 V 4...20 mA | 0...10 V 4...20 mA | 12 bits | Removable screw terminal block (supplied) | TM2AMM3HT | 0.085/ 0.187 |
| | J, K, T thermocouple 3-wire Pt 100 temperature probe | 0...10 V 4...20 mA | 12 bits | Removable screw terminal block (supplied) | TM2ALM3LT | 0.085/ 0.187 |
| 4 inputs and 2 outputs | 0...10 V 4...20 mA | 0...10 V 4...20 mA | 12 bits | Removable screw terminal block (supplied) | TM2AMM6HT | 0.085/ 0.187 |

Separate components

| Description | Description | Reference | Weight kg/ lb |
|------------------------------------|--|---------------------|---------------------|
| Ground connection plate | Plate equipped with male Faston connector for connecting cable shielding (via Faston clamp 6.35 mm/0.25 in., not supplied) and functional grounds (FG) | TM2XMTGB | 0.045/ 0.099 |
| Shielding connection clamps | Attach and ground the shielding of the cables <i>Sold in lots of 25 (20 for cable Ø 4.8 mm/Ø 0.19 in. and 5 for cable Ø 7.9 mm/Ø 0.31 in.)</i> | TM200RSRCEMC | – |
| Mounting kit | For plate or panel mounting of the analog modules. <i>Sold in lots of 5</i> | TWDXMT5 | 0.065/ 0.143 |

Presentation

TM200HSC206DT/DF Expert modules for Modicon M238 logic controllers and HMI controllers XBTGC are used to count the pulses generated by a sensor or to process the signals from an incremental encoder.

The two modules, both with two 60 KHz counter channels, differ in the way they are connected:

- Removable screw terminal block (2 x 16 contacts): **TM200HSC206DT**
- Removable spring terminals **TM200HSC206DF**

| Expert modules | No. of channels | Maximum frequency | Integrated functions | Physical I/O per channel | |
|--|-----------------|-------------------|---|--------------------------|---------|
| | | | | Inputs | Outputs |
| TM200HSC206DT TM200HSC206DF (3 modules max. per controller.) | 2 | 60 KHz | Upcounting Downcounting Period meter Frequency meter Frequency generator Axis following with encoder | 6 | 2 |

The sensors used on each channel can be:

- 2-wire 24 V proximity sensors,
- 3-wire PNP 24 V proximity sensors,
- Limit switches (N/O or N/C contact),
- 15/30 V output signal incremental encoders and source outputs (positive logic).

TM200HSC206D Expert modules meet the requirements of such applications as:

- Message generation on empty unwinder status using the ratio,
- Sorting small parts using the period meter,
- Single electronic cam using the dynamic setting thresholds,
- Speed control using the period meter,
- Grouping/ungrouping for packaging machines,
- Event counting,
- Flow or speed measurement.

TM200HSC206D Expert modules are considered to be expansion modules and as such are connected to a controller by stacking them on a symmetrical rail, starting at the right-hand side panel of each controller.

The function parameters are set by configuration using SoMachine software.

Description

TM200HSC206D 60 KHz Expert modules comprise:

- 1 An extension connector for linking with the adjacent module (1).
- 2 A channel and module diagnostics display block.
- 3 2 removable screw or spring terminal blocks marked TB0 and TB1 for connecting the sensors and preactuators.
- 4 A mechanical device for locking to the adjacent module.
- 5 A screw terminal for the functional ground (FG) connection.

The **TM2XMTGB** ground connection plate 6 simplifies connection of the sensor and encoder cable shielding. Connect this shielding to the device's functional ground.

These modules are mounted as standard on a symmetrical  rail. The **TWDXMT5** mounting kit can be used for plate or panel mounting.

(1) A connector on the right-hand side panel makes continuity of the link with the adjacent I/O module.

Operation

Block diagram of a TM200HSC206DT/DF module counter channel

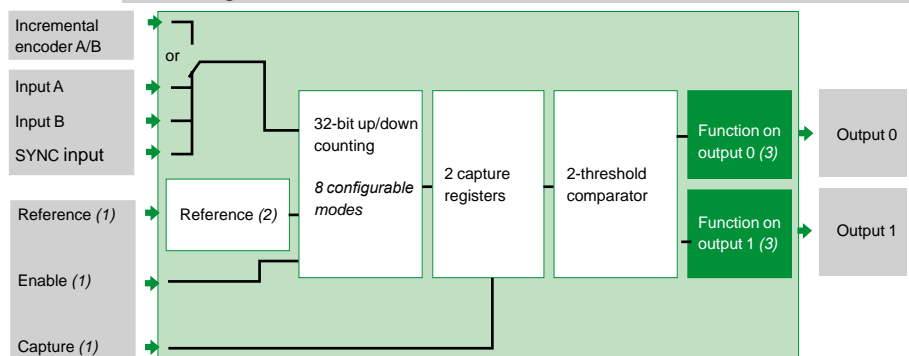

(1) Optional inputs.

(2) Reference: 4 operating modes for "IN_SYNC" SYNC and "IN_REF" Reference inputs.

(3) Function on outputs: 11 possible types of behaviour.

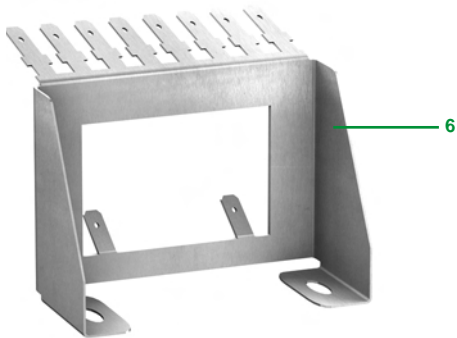
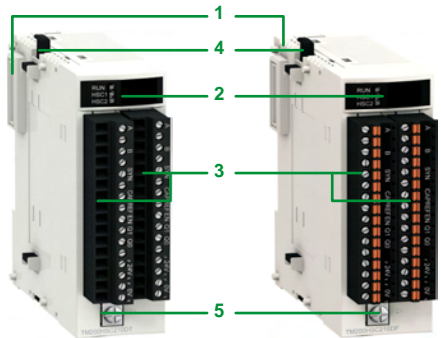



TM200HSC206DT



TM200HSC206DF

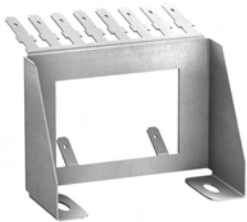

TM2XMTGB

References

| Expert modules (3 modules max. per controller) | | | | | |
|--|-----------------|-----------------|------------------|---------------|-----------------|
| Description | No. of channels | Characteristics | Connection | Reference | Weight kg/lb |
| Counter modules for: - 24 V $\overline{\text{DC}}$ 2 and 3-wire sensors - 15/30 V $\overline{\text{DC}}$ incremental encoders with source outputs (positive logic) | 2 | 60 kHz counting | Screw terminals | TM200HSC206DT | 0.150/ 0.331 |
| | | | Spring terminals | TM200HSC206DF | 0.150/ 0.331 |

Separate parts

| Designation | Description | Reference | Weight kg/lb |
|--|--|-----------|-----------------|
| Ground connection plate | Support equipped with 10 male Faston connectors for connecting the cable shielding (via 6.35 mm/0.25 in. connectors, not supplied) and the functional grounds (FG) | TM2XMTGB | 0.045/ 0.099 |
| Mounting kit <i>Sold in lots of 5</i> | For plate or panel mounting of the analog modules | TWDXMT5 | 0.065/ 0.143 |



Compatibility of offers

Modicon TM3 expansion modules

- > Modicon M221 logic controllers
- > Modicon M221 Book logic controllers
- > Modicon M241 logic controllers
- > Modicon M251 logic controllers
- > SoMachine Basic software
- > SoMachine software
- > Modicon TM2 expansion modules

3



Digital I/O modules



Analog I/O modules



Expert I/O modules



Functional Safety modules



Bus expansion modules

Presentation

The Modicon TM3 expansion module offer provides an opportunity to enhance the capabilities of Modicon M221, M241 and M251 logic controllers:

- Digital I/O modules which can be used to create configurations with up to 264 digital I/O (according to the controller). These modules are available with the same connections as the controllers.
- Analog I/O modules which can be used to create configurations with up to 114 analog I/O (according to the controller) and are designed to receive, amongst other things, position, temperature or speed sensor signals. They are also capable of controlling variable speed drives or any device equipped with a current or voltage input.
- Expert modules for control of TeSys motor starters which simplify wiring up the control section due to connection with RJ45 cables.
- Functional Safety modules which simplify wiring and can be configured in the SoMachine Basic software.

In addition, the TM3 expansion system is flexible due to the possibility of remotely locating some of the TM3 modules in the enclosure or another cabinet (up to 5 meters (16.404 ft.) away, using a bus expansion system.

The Modicon TM3 expansion system is common to the whole range of Modicon M221, M241 and M251 logic controllers, meaning that the model of controller can be revised without changing expansion module.

Modicon TM3 range

See page

| | | |
|----------------------------------|---|------|
| Digital I/O modules | <input type="checkbox"/> modules with 8 to 32 inputs/outputs: | 3/22 |
| | - 24 V or 120 V $\overline{\text{---}}$ 50/60 Hz inputs | |
| | - relay or transistor outputs | |
| Analog I/O modules | <input type="checkbox"/> modules with 2 to 8 inputs/outputs: | 3/26 |
| | - current/voltage or temperature inputs | |
| | - current/voltage outputs | |
| Expert module | <input type="checkbox"/> module for control of between one and four TeSys motor starters | 3/30 |
| Functional Safety modules | <input type="checkbox"/> modules designed using Preventa technology for integral machine safety: | 3/32 |
| | - control of emergency stops | |
| | - control of switches | |
| | - control of light curtains | |
| | - control of pressure-sensitive mats or edges | |
| Bus expansion system | <input type="checkbox"/> transmitter module | 3/36 |
| | <input type="checkbox"/> receiver module | |
| | <input type="checkbox"/> bus expansion cable | |

Specific features

Modicon TM3 expansion modules have been designed with a simple interlocking assembly mechanism. A bus expansion connector is used to distribute data and the power supply when assembling the Modicon TM3 expansion modules with logic controllers.

Connections

A wide choice of connections is available depending on the model of Modicon TM3 module:

- removable screw terminal blocks (1)
- removable spring terminal blocks (1)
- HE 10 connector, to be used with HE 10 cables/bare wires or HE 10/HE 10 and Telefast sub-bases (2)

The connectors (screw terminal blocks, spring terminal blocks, HE 10 connector, RJ 45) are located on the front of the TM3 expansion modules and are therefore accessible.

(1) The terminal blocks are supplied with Modicon TM3 expansion modules.

(2) Telefast Modicon ABE7 pre-wired system to be ordered separately (see page 2/17).

Expansion modules

Modicon TM3 expansion modules

Bus expansion system

Presentation

Modicon TM3 bus expansion system

A PLC configuration consists of a controller with its embedded input and output channels, used in conjunction with local or remote expansion modules which are used to increase the number of channels and/or functions.

- Expansion modules are connected directly by simple interlocking with the controller (local I/O) or remotely (remote I/O) with a TM3 bus expansion cable, up to 5 meters (16.404 ft.) away.
- The bus expansion connector, located on the side of the controllers and on each side of the Modicon TM3 expansion modules, transmits and synchronizes data.

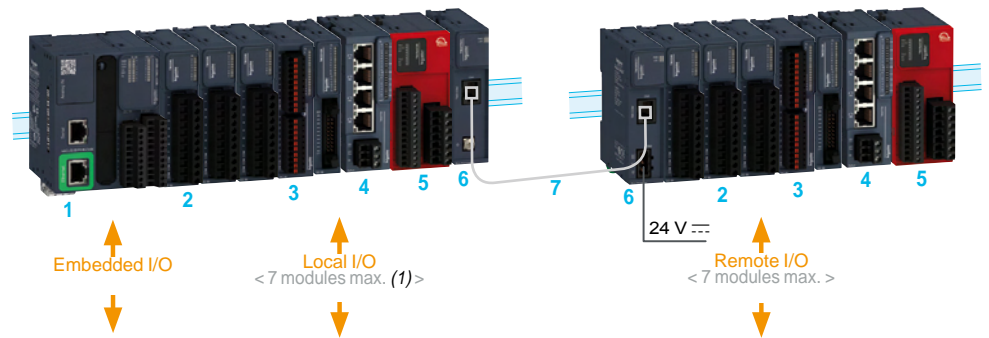

3

- 1 Logic controller (M221, M221 Book, M241, M251)
- 2 Modicon TM3 digital I/O modules.
- 3 Modicon TM3 analog I/O modules.
- 4 Modicon TM3 expert module: control of TeSys motor starters.
- 5 Modicon TM3 functional safety modules.
- 6 Modicon TM3 bus expansion module (transmitter and receiver).
- 7 TM3 bus expansion cable.

■ Local I/O

Maximum configuration: 7 Modicon TM3 expansion modules associated with an M2●● logic controller.

With limited number of relay or transistor outputs (see page 3/24).

■ Remote I/O

Maximum configuration: 14 Modicon TM3 expansion modules (7 local modules + 7 remote modules) with the use of Modicon TM3 bus expansion system (transmitter and receiver modules).

The transmitter and receiver bus expansion modules can be used to:

- increase from 7 to 14 the number of I/O expansion modules that can be connected to an M2●● logic controller
- locate Modicon TM3 expansion modules remotely, up to 5 meters (16.404 ft.) away

The transmitter module and receiver module are physically linked by a **VDIP184546●●●** bus expansion cable.

Mounting

- Modicon TM3 expansion modules are mounted on a \perp symmetrical rail. They have a locking clip on the top of their casing.
- For plate or panel mounting, use the **TMAM2** kit.

(1) Depending on type of TM3 module used (see page 3/24).

Expansion modules

Modicon TM3 digital I/O modules

| | |
|---------------------|------------------------------|
| Applications | Expansion module type |
| | Compatibility |

| |
|--|
| Digital inputs |
| <ul style="list-style-type: none"> Modicon M221 and Modicon M221 Book logic controllers Modicon M241 logic controllers Modicon M251 logic controllers |

| | |
|------------------------|--------------------------------|
| Digital outputs | Digital inputs/ outputs |
|------------------------|--------------------------------|

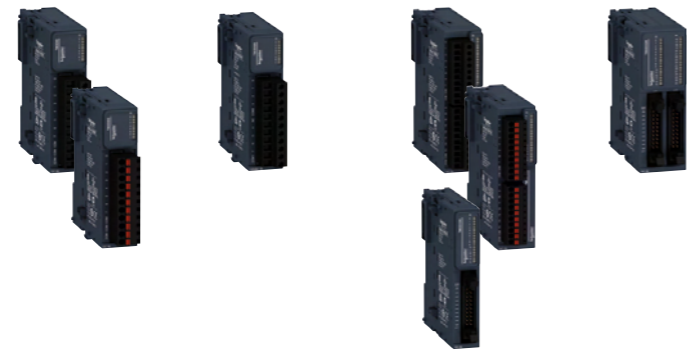

| | |
|---------------|----------------------------------|
| Inputs | Number and type of inputs |
| | Rated voltage |
| | Input type |
| | Input logic |

| | | | |
|---------------------------------|----------------|------------------------------|------------------------------|
| 8 logic inputs | 8 logic inputs | 16 logic inputs | 32 logic inputs |
| 24 V $\overline{\text{---}}$ | 120 V \sim | 24 V $\overline{\text{---}}$ | 24 V $\overline{\text{---}}$ |
| Type 1 (IEC 61131-2, Edition 3) | | | |
| sink/source | – | sink/source | sink/source |

| | |
|----------------|--|
| Outputs | No. and type of outputs |
| | Rated voltage |
| | Type of contact |
| | Logic |
| | Max. output current |
| | <input type="checkbox"/> Per output |
| | <input type="checkbox"/> Per group of channels |

| | | | |
|---|---|---|---|
| – | – | – | – |
| – | – | – | – |
| – | – | – | – |
| – | – | – | – |
| – | – | – | – |
| – | – | – | – |

| | |
|---------------------------|---|
| Supply voltage | Power supplied by the controller via the bus expansion connector |
| Format (w x h x d) | mm (in.) |

| | | | |
|--|--|---|--|
| 23.6 x 90 x 70 (0.93 x 3.54 x 2.76) | 23.6 x 90 x 70 (0.93 x 3.54 x 2.76) | TM3DI16, TM3DI16G: 23.6 x 90 x 70 (0.93 x 3.54 x 2.76) TM3DI16K: 17.6 x 90 x 70 (0.69 x 3.54 x 2.76) | 30.2 x 90 x 70 (1.19 x 3.54 x 2.76) |
|--|--|---|--|

| | |
|-----------------|--|
| Mounting | Mounting on \perp symmetrical rail or panel with specific mounting kit TMAM2 |
|-----------------|--|

| | | | |
|--|--|--|--|
| Mounting on \perp symmetrical rail or panel with specific mounting kit TMAM2 | | | |
|--|--|--|--|

| | |
|--------------------|---|
| Module type | Channels connected: |
| | with removable screw terminal blocks with a thread of 5.08 mm (0.2 in.) |
| | with removable screw terminal blocks with a thread of 3.81 mm (3.81 mm.) |
| | with removable spring terminal blocks with a thread of 5.08 mm (0.2 in.) |
| | with removable spring terminal blocks with a thread of 3.81 mm (3.81 mm.) |
| | with HE 10 connectors (1) |

| | | | |
|---------|---------|----------|----------|
| TM3DI8 | TM3DI8A | – | – |
| – | – | TM3DI16 | – |
| TM3DI8G | – | – | – |
| – | – | TM3DI16G | – |
| – | – | TM3DI16K | TM3DI32K |

| | |
|--------------|------|
| Pages | 3/25 |
|--------------|------|

| |
|------|
| 3/25 |
|------|

(1) Compatible with the Telefast Modicon ABE7 pre-wired system (see page 2/17).

| | | | | | | | | | | | |
|---|---|---|---|---|---|---|---|---|---|---------------------------------|------------------------------|
| – | – | – | – | – | – | – | – | – | – | 4 logic inputs | 16 logic inputs |
| – | – | – | – | – | – | – | – | – | – | 24 V $\overline{\text{---}}$ | 24 V $\overline{\text{---}}$ |
| – | – | – | – | – | – | – | – | – | – | Type 1 (IEC 61131-2, Edition 3) | |
| – | – | – | – | – | – | – | – | – | – | sink/source | sink/source |

| | | | | | | | | | |
|--|------------------------------|------------------------------|--|---|---|------------------------------|------------------------------|--|--|
| 8 relay outputs | 8 transistor outputs | 8 transistor outputs | 16 relay outputs | 16 transistor outputs | 16 transistor outputs | 32 transistor outputs | 32 transistor outputs | 4 relay outputs | 8 relay outputs |
| 24 V $\overline{\text{---}}$ / 240 V \sim | 24 V $\overline{\text{---}}$ | 24 V $\overline{\text{---}}$ | 24 V $\overline{\text{---}}$ / 240 V \sim | 24 V $\overline{\text{---}}$ | 24 V $\overline{\text{---}}$ | 24 V $\overline{\text{---}}$ | 24 V $\overline{\text{---}}$ | 24 V $\overline{\text{---}}$ / 240 V \sim | 24 V $\overline{\text{---}}$ / 240 V \sim |
| 1 N/O contact | – | – | 1 N/O contact | – | – | – | – | 1 N/O contact | 1 N/O contact |
| – | Source | Sink | – | Source | Sink | Source | Sink | – | – |
| 2 A | 0.5 A | 0.5 A | 2 A | 0.5 A for TM3DQ16T and TM3DQ16TG 0.1 A for TM3DQ16TK | 0.5 A for TM3DQ16U and TM3DQ16UG 0.1 A for TM3DQ16UK | 0.1 A | 0.1 A | 2 A | 2 A |
| 7 A | 4 A | 4 A | 8 A | 4 A for TM3DQ16T and TM3DQ16TG 2 A for TM3DQ16TK | 2 A | 2 A | 2 A | 7 A | 7 A |

| | | | | |
|--|---|--|--|--|
| 23.6 x 90 x 70 (0.93 x 3.54 x 2.76) | TM3DQ16T, TM3DQ16TG, TM3DQ16U, TM3DQ16UG: 23.6 x 90 x 70 (0.93 x 3.54 x 2.76) TM3DQ16TK, TM3DQ16UK: 17.6 x 90 x 70 (0.69 x 3.54 x 2.76) | 30.2 x 90 x 70 (1.19 x 3.54 x 2.76) | 23.6 x 90 x 70 (0.93 x 3.54 x 2.76) | 39.1 x 90 x 70 (1.53 x 3.54 x 2.76) |
|--|---|--|--|--|

| | | | | | | | | | |
|--|--|--|--|--|--|--|--|--|--|
| Mounting on \perp symmetrical rail or panel with specific mounting kit TMAM2 | | | | | | | | | |
|--|--|--|--|--|--|--|--|--|--|

| | | | | | | | | | | | |
|----------|----------|----------|-----------|-----------|-----------|------------------|------------------|---|---|----------|-----------|
| TM3DQ8R | TM3DQ8T | TM3DQ8U | – | – | – | – | – | – | – | TM3DM8R | – |
| – | – | – | TM3DQ16R | TM3DQ16T | TM3DQ16U | – | – | – | – | – | TM3DM24R |
| TM3DQ8RG | TM3DQ8TG | TM3DQ8UG | – | – | – | – | – | – | – | TM3DM8RG | – |
| – | – | – | TM3DQ16RG | TM3DQ16TG | TM3DQ16UG | – | – | – | – | – | TM3DM24RG |
| – | – | – | – | TM3DQ16TK | TM3DQ16UK | TM3DQ32TK (1) | TM3DQ32UK (1) | – | – | – | – |

| |
|------|
| 3/25 |
|------|

(1) Compatible with the Telefast Modicon ABE7 pre-wired system (see page 2/17).

Presentation

The Modicon TM3 digital I/O module offer consists of 27 modules: input modules, output modules and mixed I/O modules. These digital I/O modules complement the embedded I/O on M221, M221 Book, M241 and M251 logic controllers.

Breakdown of the offer

- Digital I/O modules**
- with 8, 16 or 32 x 24 V $\overline{\text{DC}}$ inputs
 - with 8 x 120 V \sim inputs
 - with 8 or 16 relay outputs
 - with 8, 16 or 32 source transistor 24 V $\overline{\text{DC}}$ outputs
 - with 8, 16 or 32 sink transistor 24 V $\overline{\text{DC}}$ outputs
 - with 4 x 24 V $\overline{\text{DC}}$ inputs and 4 relay outputs
 - with 16 transistor 24 V $\overline{\text{DC}}$ inputs and 8 relay outputs

Connections

- Thanks to a wide choice of modules, it is possible to create homogenous configurations in terms of connections:
- Screw terminal blocks with a thread of 5.08 mm (0.2 in.) for ease of wiring: identical to the connectors on M221 and M241 logic controllers.
 - Screw or spring-type connectors with a thread of 3.81 mm (0.15 in.) for compact dimensions: identical to the connectors on **TM221M16●●** and **TM221ME16●●** controllers.
 - HE10 type connectors that can minimize wiring costs thanks to the Telefast pre-wired system: identical to the connectors on **TM221M32TK** and **TM221ME32TK** controllers.

Configuration

- Local I/O (1): up to 7 I/O modules can be attached to the controller while complying with the restrictions indicated in the table below.
- Remote I/O (1) with TM3 bus expansion system: 7 additional I/O modules can be used without restriction. These modules are attached to a **TM3XREC1** receiver module.

| Logic controllers | TM221 | | | | | | | | | TM241/TM251 |
|--|---------------|---------------|---------------|---------------|---------------|---------------|----------------------------------|----------------------------------|-----------------|-------------|
| | C16R CE16R | C16T CE16T | C24R CE24R | C24T CE24T | C40R CE40R | C40T CE40T | M16R ME16R M16RG ME16RG | M16T ME16T M16TG ME16TG | M32TK ME32TK | |
| Maximum number of TM3 module transistor (local) outputs directly connected to the controller (2) | 104 | 136 | 144 | 176 | (3) | | | | | |
| Maximum number of TM3 module relay (local) outputs directly connected to the controller (2) | 23 | 28 | 32 | 40 | 48 | 60 | 92 | 96 | 96 | (3) |

(1) Local I/O and remote I/O: see page 3/21.

(2) If using bus expansion system: maximum number of TM3 module relay or transistor outputs installed between the controller and the **TM3XTRA1** transmitter module (local outputs).

(3) Up to 7 TM3 modules regardless of the number of outputs used.

Mounting

- Digital I/O modules are mounted on a \perp symmetrical rail.
- For plate or panel mounting, use the **TMAM2** kit.

Description

Modicon TM3 digital I/O modules

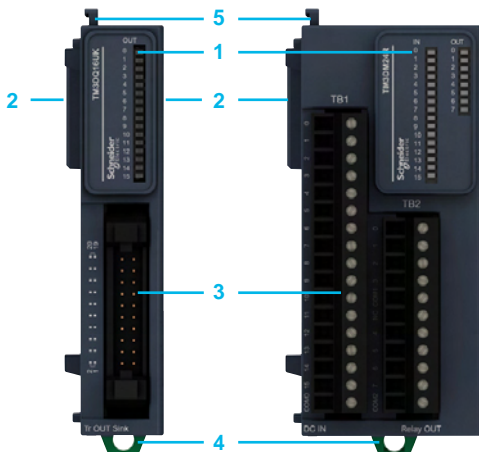

- 1 LED display block for the module channels and diagnostics
- 2 TM3 bus connectors (one on each side). These are designed to provide continuity of the link between connected modules.
- 3 Input or output channel terminal blocks (depending on model: screw terminal blocks, spring terminal blocks or HE 10 connector).
- 4 \perp symmetrical rail locking clip.
- 5 Adjacent module locking latch.



TM3DI8



TM3DI8A



TM3DI16G



TM3DQ16U



TM3DQ16UG



TM3DQ16UK



TM3DQ32TK



TM3DQ32UK



TM3DM24R



TM3DM24RG

References

Modicon TM3 digital input modules

| Number of logic inputs | Input type | Term. block for input conn. (1) Thread (mm/in.) | References | Weight kg/ lb |
|------------------------|---|--|------------|---------------------|
| 8 inputs | sink/source 24 V $\overline{\text{---}}$ | screw 5.08/0.2 | TM3DI8 | 0.110/ 0.243 |
| | | spring 5.08/0.2 | TM3DI8G | 0.095/ 0.209 |
| | 120 V \sim | screw 5.08/0.2 | TM3DI8A | 0.110/ 0.243 |
| | | spring 5.08/0.2 | TM3DI8G | 0.095/ 0.209 |
| 16 inputs | sink/source 24 V $\overline{\text{---}}$ | screw 3.81/0.15 | TM3DI16 | 0.105/ 0.231 |
| | | spring 3.81/0.15 | TM3DI16G | 0.095/ 0.209 |
| | HE 10 connector – | HE 10 connector (2) | TM3DI16K | 0.075/ 0.165 |
| | | HE 10 connector (2) | TM3DI32K | 0.110/ 0.243 |

Modicon TM3 digital output modules

| Number of logic outputs | Output type | Output current | Term. block for output conn. (1) Thread (mm/in.) | References | Weight kg/ lb | | |
|-------------------------|-----------------------|-----------------------|---|---------------------|---------------------|-----------------|-----------------|
| 8 outputs | Relay | 2 A | screw 5.08/0.2 | TM3DQ8R | 0.130/ 0.287 | | |
| | | | spring 5.08/0.2 | TM3DQ8RG | 0.115/ 0.254 | | |
| | | Transistor, source | 0.5 A | screw 5.08/0.2 | TM3DQ8T | 0.110/ 0.243 | |
| | | | | spring 5.08/0.2 | TM3DQ8TG | 0.095/ 0.209 | |
| | Transistor, sink | 0.5 A | screw 5.08/0.2 | TM3DQ8U | 0.110/ 0.243 | | |
| | | | spring 5.08/0.2 | TM3DQ8UG | 0.095/ 0.209 | | |
| | 16 outputs | Relay | 2 A | screw 3.81/0.15 | TM3DQ16R | 0.140/ 0.309 | |
| | | | | spring 3.81/0.15 | TM3DQ16RG | 0.130/ 0.287 | |
| | | | Transistor, source | 0.5 A | screw 3.81/0.15 | TM3DQ16T | 0.105/ 0.231 |
| | | | | | spring 3.81/0.15 | TM3DQ16TG | 0.095/ 0.209 |
| | | 0.1 A | HE 10 connector – | TM3DQ16TK (2) | 0.075/ 0.165 | | |
| | | | – | – | – | – | |
| Transistor, sink | | 0.5 A | screw 3.81/0.15 | TM3DQ16U | 0.105/ 0.231 | | |
| | | | spring 3.81/0.15 | TM3DQ16UG | 0.095/ 0.209 | | |
| 32 outputs | Transistor, source | 0.1 A | HE 10 connector (2) | TM3DQ32TK | 0.115/ 0.254 | | |
| | | | – | – | – | | |
| | Transistor, sink | 0.1 A | HE 10 connector (2) | TM3DQ32UK | 0.115/ 0.254 | | |
| | | | – | – | – | | |

Modicon TM3 digital mixed I/O modules

| No. of logic I/O | Number and type of inputs | Number and type of outputs | Term. block for output conn. (1) Thread (mm/in.) | References | Weight kg/ lb |
|-------------------|--|----------------------------|---|------------|---------------------|
| 8 inputs/outputs | 4 sink/source 24 V $\overline{\text{---}}$ inputs | 4 relay outputs 2 A | screw 5.08/0.2 | TM3DM8R | 0.120/ 0.265 |
| | | | spring 5.08/0.2 | TM3DM8RG | 0.100/ 0.220 |
| 24 inputs/outputs | 16 sink/source 24 V $\overline{\text{---}}$ inputs | 8 relay outputs 2 A | screw 3.81/0.15 | TM3DM24R | 0.165/ 0.364 |
| | | | spring 3.81/0.15 | TM3DM24RG | 0.155/ 0.342 |

Separate parts

| Designation | Description | Reference | Weight kg/ lb |
|--|--|------------|---------------------|
| Mounting kit Sold in lots of 10 | For plate or panel mounting of digital I/O modules | TMAM2 | 0.065/ 0.143 |
| Set of terminal blocks for connecting the I/O | 4 x 10-way and 4 x 11-way removable terminal blocks with screw terminals for TM3DI16, TM3DQ16R, TM3DQ16T and TM3DQ16U modules | TMAT2MSET | 0.127/ 0.280 |
| | 4 x 10-way and 4 x 11-way removable terminal blocks with spring terminals for TM3DI16G, TM3DQ16RG, TM3DQ16TG and TM3DQ16UG modules | TMAT2MSETG | 0.127/ 0.280 |

(1) Removable screw or spring-type terminal blocks, supplied.

(2) Modules compatible with the Telefast Modicon ABE7 pre-wired system (see page 2/21).

Expansion modules

Modicon TM3 analog I/O modules

| Applications | Type of expansion module |
|--------------|--------------------------|
| | Compatibility |

| Analog inputs |
|--|
| <ul style="list-style-type: none"> Modicon M221 and M221 Book logic controllers Modicon M241 logic controllers Modicon M251 logic controllers |

| Analog inputs | Analog outputs | Analog inputs/outputs |
|---------------|----------------|-----------------------|
|---------------|----------------|-----------------------|



| Inputs | Number |
|--------|------------|
| | Type |
| | Range |
| | Resolution |
| | Read time |

| 2 inputs | 4 inputs | 4 inputs | 8 inputs |
|--|--|--|--|
| Voltage/current | Voltage/current | Temperature or voltage/current | Voltage/current |
| - 10...+ 10 VDC, 0...+ 10 VDC / 0...20 mA, 4...20 mA | - 10...+ 10 VDC, 0...+ 10 VDC / 0...20 mA, 4...20 mA | Thermocouples (J, K, R, S, B, T, N, E, C) Temperature probes (RTDs): (Ni100, Ni1000, PT100, PT1000) - 10...+ 10 VDC, 0...+ 10 VDC / 0...20 mA, 4...20 mA | - 10...+ 10 VDC, 0...+ 10 VDC / 0...20 mA, 4...20 mA |
| 16 bits or 15 bits + sign | 12 bits or 11 bits + sign | 16 bits or 15 bits + sign | 12 bits or 11 bits + sign |
| 1 or 10 ms (configurable) | 1 or 10 ms (configurable) | 100 ms per channel for temperature signals. 1 or 10 ms (configurable) for voltage/current signals | 1 or 10 ms (configurable) |

| Outputs | Number |
|---------|---------------|
| | Type |
| | Range |
| | Resolution |
| | Transfer time |

| 2 outputs | 4 outputs | 1 output | 2 outputs |
|--|--|--|--|
| Voltage/current | Voltage/current | Voltage/current | Voltage/current |
| - 10...+ 10 VDC, 0...+ 10 VDC / 0...20 mA, 4...20 mA | - 10...+ 10 VDC, 0...+ 10 VDC / 0...20 mA, 4...20 mA | - 10...+ 10 VDC, 0...+ 10 VDC / 0...20 mA, 4...20 mA | - 10...+ 10 VDC, 0...+ 10 VDC / 0...20 mA, 4...20 mA |
| 12 bits or 11 bits + sign | 12 bits or 11 bits + sign | 12 bits or 11 bits + sign | 12 bits or 11 bits + sign |
| 1 or 10 ms (configurable) | 1 or 10 ms (configurable) | 1 or 10 ms (configurable) | 1 or 10 ms (configurable) |

| Supply voltage | With a 24 V $\overline{\text{DC}}$ external power supply |
|-----------------------------|--|
| Format (w x h x d) mm (in.) | 23.6 x 90 x 70 (0.93 x 3.54 x 2.76) |
| Mounting | Mounting on \perp symmetrical rail or panel with specific mounting kit TMAM2 |

| Supply voltage | With a 24 V $\overline{\text{DC}}$ external power supply |
|-----------------------------|--|
| Format (w x h x d) mm (in.) | 23.6 x 90 x 70 (0.93 x 3.54 x 2.76) |
| Mounting | Mounting on \perp symmetrical rail or panel with specific mounting kit TMAM2 |

| Type of module | Channel connection: via removable screw terminal blocks at intervals of 5.08 (0.2 in.) via removable screw terminal blocks at intervals of 3.81 (0.15 in.) via removable spring terminal blocks at intervals of 5.08 (0.2 in.) via removable spring terminal blocks at intervals of 3.81 (0.15 in.) |
|----------------|---|
|----------------|---|

| | | | |
|----------|---------|---------|---------|
| TM3AI2H | - | - | - |
| - | TM3AI4 | TM3TI4 | TM3AI8 |
| TM3AI2HG | - | - | - |
| - | TM3AI4G | TM3TI4G | TM3AI8G |

| | | | | |
|----------|---------|---------|---------|---------|
| - | TM3AQ2 | TM3AQ4 | TM3TM3 | - |
| TM3TI8T | - | - | - | TM3AM6 |
| - | TM3AQ2G | TM3AQ4G | TM3TM3G | - |
| TM3TI8TG | - | - | - | TM3AM6G |

| Pages | 3/29 |
|-------|------|
|-------|------|

| Pages | 3/29 |
|-------|------|
|-------|------|

Presentation

The Modicon TM3 analog I/O module offer consists of 18 input, output and mixed input/output modules. The input modules acquire various analog values encountered in industrial applications.

These I/O modules complement the embedded I/O in Modicon M221, M221 Book and M241 logic controllers.

- **TM3AI●●** and **TM3TI●●** analog input modules are used to acquire various analog values (voltage, current or temperature) encountered in industrial applications.
- **TM3AQ●●** analog output modules are used to control preactuators in physical units, such as variable speed drives or valves and applications where process control is required.
- **TM3TM●●** and **TM3AM●●** mixed modules combine voltage/current or temperature analog inputs as well as one or two voltage/current outputs in the same case.
- When the controller stops, the outputs of each TM3 analog modules can be configured to fall back (hold the last value or a specified value). This function, when set to "hold", is useful when debugging the application or when a fault occurs, in order not to disturb the process being controlled.

Breakdown of the offer

- Analog I/O modules** Modules with 2 to 8 analog I/O:
- voltage/current or temperature inputs
 - voltage/current outputs

Format

A single format: 23.6 x 90 x 70 (0.93 x 3.54 x 2.76 in.).

Connection

With a wide selection of modules, uniform configurations can be created in terms of connectors:

- Screw-type or spring-type connectors at intervals of 5.08 (0.2 in.) for ease of wiring: identical to the connectors on Modicon M221 (TM221C●●●●) and Modicon M241 (TM241C●●●●) logic controllers.
- Screw-type or spring-type connectors at intervals of 3.81 (0.15 in.) for compact dimensions: identical to the connectors on Modicon M221 Book (TM221M16●● and TM221ME16●●) logic controllers.

Configuration

- Analog I/O modules connect to Modicon M221 and M221 Book, M241 and M251 logic controllers according to the general rules for the Modicon TM3 system: 7 modules max. and 14 modules max. with use of Modicon TM3 bus expansion system (transmitter and receiver).
- An external 24 V $\overline{\text{---}}$ power supply is required for each Modicon TM3 analog module.
- The I/O modules are designed with isolation by an optocoupler between the internal electronics and the I/O channels.

Mounting

- The analog modules are mounted on a \perp symmetrical rail.
- For plate or panel mounting, use the **TMAM2** kit.
- The **TM2XMTGB** grounding plate simplifies connection of the analog sensor and actuator cable shielding (shielding to be connected to the device's functional ground).

Description

Modicon TM3 analog modules

- 1 Locking latch for the adjacent module.
- 2 TM3 bus connectors (one on each side). These are designed to provide continuity of the link between connected modules.
- 3 Clip for locking on \perp symmetrical rail.
- 4 Module "Power on" LED.
- 5 Removable spring or screw terminal blocks (depending on the model) for connecting the analog channels and the 24 V power supply.

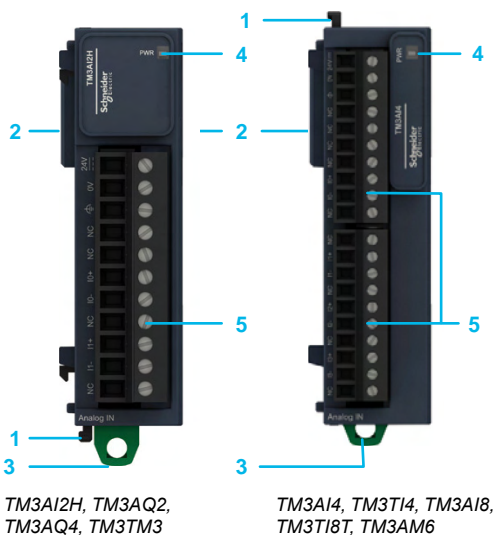



TM3AI2H TM3AI4



TM3TI4 TM3AI8



TM3TI8T



TM3AQ2 TM3AQ4



TM3TM3 TM3AM6



TM200 RSRCEMC



TM2XMTGB

References

Modicon TM3 analog I/O modules

| Number and type of channels | Input range | Output range | Resolution | Conn. block for the inputs (1) Pitch (in.) | Reference | Weight kg/ lb |
|---|--|--------------|------------------------------|---|-----------|---------------------|
| 2 voltage/current inputs | - 10...+ 10 VDC, 0...+ 10 VDC/ 0...20 mA, 4...20 mA | - | 16 bits or 15 bits + sign | Screw 5.08/0.2 | TM3AI2H | 0.115/ 0.254 |
| | | | | Spring 5.08/0.2 | TM3AI2HG | 0.100/ 0.220 |
| 4 voltage/current inputs | - 10...+ 10 VDC, 0...+ 10 VDC/ 0...20 mA, 4...20 mA | - | 12 bits or 11 bits + sign | Screw 3.81/0.15 | TM3AI4 | 0.110/ 0.243 |
| | | | | Spring 3.81/0.15 | TM3AI4G | 0.100/ 0.220 |
| 4 voltage/current or temperature inputs (2) | <input type="checkbox"/> Thermocouples (J, K, R, S, B, T, N, E, C) <input type="checkbox"/> Temperature probes (RTDs) (Ni100, Ni1000, PT100, PT1000) <input type="checkbox"/> - 10...+ 10 VDC, 0...+ 10 VDC) /0...20 mA, 4...20 mA) | - | 16 bits or 15 bits + sign | Screw 3.81/0.15 | TM3TI4 | 0.110/ 0.243 |
| | | | | Spring 3.81/0.15 | TM3TI4G | 0.100/ 0.220 |
| 8 voltage/current inputs | - 10...+ 10 VDC, 0...+ 10 VDC/ 0...20 mA, 4...20 mA | - | 12 bits or 11 bits + sign | Screw 3.81/0.15 | TM3AI8 | 0.110/ 0.243 |
| | | | | Spring 3.81/0.15 | TM3AI8G | 0.100/ 0.220 |
| 8 temperature inputs | <input type="checkbox"/> Thermocouples (J, K, R, S, B, T, N, E, C) <input type="checkbox"/> NTC and PTC thermistors | - | 16 bits or 15 bits + sign | Screw 3.81/0.15 | TM3TI8T | 0.110/ 0.243 |
| | | | | Spring 3.81/0.15 | TM3TI8TG | 0.100/ 0.220 |

Modicon TM3 analog output modules

| | | | | | | |
|---------------------------|---|--|------------------------------|--------------------|---------|-----------------|
| 2 voltage/current outputs | - | - 10...+ 10 VDC, 0...+ 10 VDC/ 0...20 mA, 4...20 mA | 12 bits or 11 bits + sign | Screw 5.08/0.2 | TM3AQ2 | 0.115/ 0.254 |
| | | | | Spring 5.08/0.2 | TM3AQ2G | 0.100/ 0.220 |
| 4 voltage/current outputs | - | - 10...+ 10 VDC, 0...+ 10 VDC/ 0...20 mA, 4...20 mA | 12 bits or 11 bits + sign | Screw 5.08/0.2 | TM3AQ4 | 0.115/ 0.254 |
| | | | | Spring 5.08/0.2 | TM3AQ4G | 0.100/ 0.220 |

Modicon TM3 analog mixed I/O modules

| | | | | | | |
|--|--|--|--|---------------------|---------|-----------------|
| 2 temperature or voltage/current inputs (2) and 1 voltage/current output | <input type="checkbox"/> Thermocouples (J, K, R, S, B, T, N, E, C) <input type="checkbox"/> Temperature probes (RTDs) (Ni100, Ni1000, PT100, PT1000) <input type="checkbox"/> - 10...+ 10 VDC, 0...+ 10 VDC) /0...20 mA, 4...20 mA) | - 10...+ 10 VDC, 0...+ 10 VDC/ 0...20 mA, 4...20 mA | 16 bits or 15 bits + sign (for I) 12 bits or 11 bits + sign (for O) | Screw 5.08/0.2 | TM3TM3 | 0.115/ 0.254 |
| | | | | Spring 5.08/0.2 | TM3TM3G | 0.100/ 0.220 |
| 4 voltage/current inputs and 2 voltage/current outputs | - 10...+ 10 VDC, 0...+ 10 VDC/ 0...20 mA, 4...20 mA | - 10...+ 10 VDC, 0...+ 10 VDC/ 0...20 mA, 4...20 mA | 12 bits or 11 bits + sign (for I and O) | Screw 3.81/0.15 | TM3AM6 | 0.110/ 0.243 |
| | | | | Spring 3.81/0.15 | TM3AM6G | 0.100/ 0.220 |

Separate parts

| Description | Details | Unit reference | Weight kg/ lb |
|---|--|----------------|---------------------|
| Grounding plate | Support equipped with 10 male Faston connectors for connecting the cable shielding (via 6.35 connectors, not supplied) and the functional grounds (FE) | TM2XMTGB | 0.045/ 0.099 |
| Shielding connection clamps Sold in lots of 25 | Assembly and earthing of the cable shielding. Pack of 25 clamps including 20 for Ø 4.8 (0.189 in.) cable and 5 for Ø 7.9 (0.311 in.) cable | TM200RSRCEMC | - |
| Mounting kit Sold in lots of 10 | For mounting the analog I/O modules on a plate or panel | TMAM2 | 0.065/ 0.143 |
| Set of I/O terminal blocks | 4 terminal blocks with 10 pins and 4 terminal blocks with 11 removable screw terminal pins for TM3AI4, TM3TI4, TM3AI8, TM3TI8, TM3AM6 modules | TMAT2MSET | 0.127/ 0.280 |
| | 4 terminal blocks with 10 pins and 4 terminal blocks with 11 removable spring terminal pins for TM3AI4G, TM3TI4G, TM3AI8G, TM3TI8G, TM3AM6G modules | TMAT2MSETG | 0.127/ 0.280 |

(1) Removable screw terminal blocks supplied with each module.

(2) Each input can be configured independently for temperature or voltage/current.

Expansion modules

Modicon TM3 expert module for TeSys motor starter applications

3

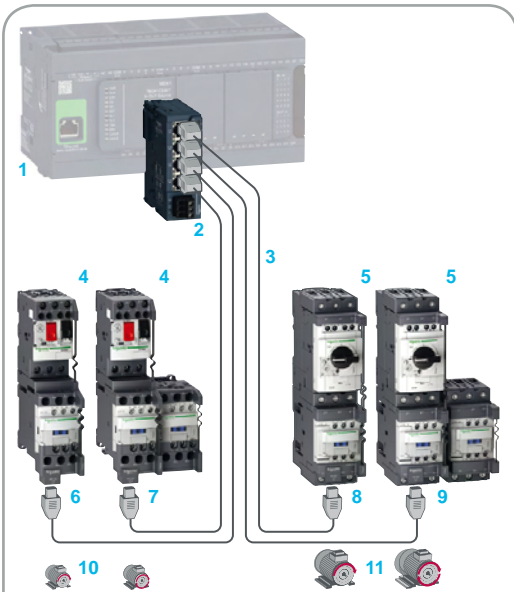

- 1 Modicon M221, M221 book, M241, M251 logic controllers
- 2 Modicon TM3XTYS4 expert Module (provides the 24 V $\overline{\text{---}}$ control voltage to the TeSys motor starter coil)
- 3 RJ45 cables LU9R●●
- 4 D.O.L. or reversing starters GV2ME●● + LC1D●●●●
- 5 D.O.L. or reversing starters GV3P●● + LC1D●●●●
- 6 Adaptor LAD5C11
- 7 Adaptor LAD5C12
- 8 Adaptor LAD5C3
- 9 Adaptor LAD5C32
- 10 Medium power motor up to 15 kW
- 11 Medium power motor up to 30 kW
- Non reversing control
- Reversing

Presentation

The **TM3XTYS4** expert module is a pre-wired interface for use with Modicon M221, M241 and M251 logic controllers, designed to monitor and control up to four motor starters.

The **TM3XTYS4** expert module is a component of TeSys Solink system that allows a simple, fast and error free wiring of the motor starter.

Controlling motor starters with the TM3XTYS4 expert module

Each of the four channels on the **TM3XTYS4** expert module has:

- Two outputs for the command of the motor starter:

- direction 1 command
- direction 2 command, if reversing starter.

- Three inputs for the motor starter status:

- Ready
- Run
- Fault

The inputs are connected in series with the motor starter auxiliary contacts.

Connections

- The **TM3XTYS4** Expert module is equipped with four RJ 45 connectors for connection to the motor starters.
- **LU9R●●●** type cordsets are dedicated to the connection of TeSys motor starter and equipped with an RJ 45 connector at each end.

Configuration

- The expert module is connected directly to the logic controllers on the TM3 bus connector or to the bus expansion system (receiver module).
- One or more expert modules can be connected to M221, M221 Book, M241 and M251 logic controllers according to the general rules for the TM3 system: 7 modules max. and 14 modules max. with the use of Modicon TM3 bus expansion system (transmitter and receiver).

Mounting

- The **TM3XTYS4** expert module is mounted on a \perp symmetrical rail.
- For plate or panel mounting, use the **TMAM2** kit.

Format

A single format: 23.6 x 90 x 70 mm (0.93 x 3.54 x 2.76 in.).

TeSys motor starter applications examples

| | Direct Up to 15 kW / 400 V | From 18.5 to 30 kW / 400 V | Reversing Up to 15 kW / 400 V | From 18.5 to 30 kW / 400 V |
|---|--|-------------------------------|--|-------------------------------|
| TeSys D | | | | |
| 1 Motor circuit breaker | GV2ME●● or GV2P●● | GV3P●● | GV2ME●● or GV2P●● | GV3P●● |
| 2 Contactor 24 V $\overline{\text{---}}$ | LC1D09BL to LC1D32BL LC1D09BD to LC1D32BD | LC1D40ABD to LC1D65ABD | LC2D09BL to LC2D32BL LC2D09BD to LC2D32BD | LC2D40BD to LC2D65BD |
| 3 Combination block | GV2AF3 | – | GV2AF3 | – |
| 4 Auxilliary contact | GVAE20 | GVAE20 | GVAE20 | GVAE20 |
| 5 Connection module | LAD5C11 | LAD5C31 | LAD5C12 | LAD5C32 |
| Connection cable | | | | |
| 6 Length of 0.3 m | LU9R03 | | | |
| 6 Length of 1 m | LU9R10 | | | |
| 6 Length of 3 m | LU9R30 | | | |
| Modicon TM3 module | | | | |
| 7 Modicon TM3 | TM3XTYS4 | | | |
| TeSys U | | | | |
| 8 Power base | LUB120 or LUB320 | | LUB120 or LUB320 | |
| 9 Control unit 24 V $\overline{\text{---}}$ | LUCA/LUCB/LUCC/LUCD●●BL | | LUCA/LUCB/LUCC/LUCD●●BL | |
| 10 Terminal blocks | LU9BN11C | | LU9MRC | |
| 11 Parallel wiring module | LUF00 | | LUF00 | |

For further information about TeSys motor starter applications, please refer to our website www.schneider-electric.com.



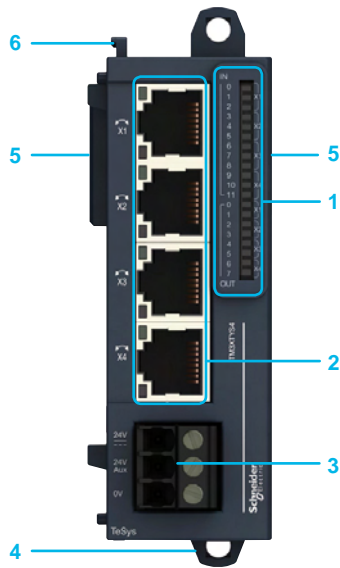

TM3XTYS4

Description

TM3XTYS4 expert module

- 1 Block with 20 LEDs displaying the status of the 12 input channels and 8 output channels.
- 2 Four RJ 45 connectors for cordsets connecting to the motor starters.
- 3 Screw terminal block for connecting the 24 V $\bar{\text{m}}$ power supply for the inputs and starter coils.
- 4 \perp symmetrical rail locking clip.
- 5 TM3 bus connectors (one on each side). These are designed to provide continuity of the link between connected modules.
- 6 Adjacent module locking latch.

References

Expert module (1)

| Designation | Number and type of channels | Reference | Weight kg/ lb |
|--|-----------------------------|-----------------|---------------------|
| Expert modules for control of TeSys motor starters 24 V $\bar{\text{m}}$ power supply (1.2 A) | 4 motor starters | TM3XTYS4 | 0.115/ 0.254 |

Separate parts

| Designation | Description | Reference | Weight kg/ lb |
|---|---|--------------|---------------------|
| Mounting kit Sold in lots of 10 | For plate or panel mounting of expert modules | TMAM2 | 0.065/ 0.143 |

(1) The **TM3XTYS4** module is supplied with a screw removable terminal block for connecting the power supply.

Expansion modules

Modicon TM3 functional safety modules

(Powered by **Preventa** technology)

Safety application



Compatibility

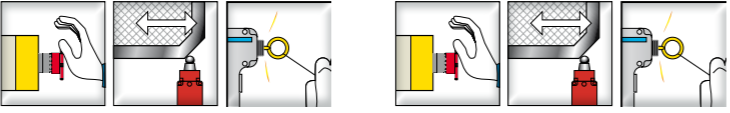

Control of Emergency stop and switches

- Modicon M221 and Modicon M221 Book logic controllers
- Modicon M241 logic controllers
- Modicon M251 logic controllers



| | | |
|--|---|---|
| Maximum achievable safety level | PLd/Category 3 conforming to EN/ISO 13849-1 SILCL2 conforming to EN/IEC 61508 and EN/IEC 62061 | PLe/Category 4 conforming to EN/ISO 13849-1 SILCL3 conforming to EN/IEC 61508 and EN/IEC 62061 |
| Standards (product) | EN/IEC 60947-1 EN/IEC 60947-5-1 | EN/IEC 60947-1 EN/IEC 60947-5-1 |
| Standards (machine assembly) | Emergency stop circuits | Emergency stop circuits |
| | Switches in protective devices | Switches in protective devices |
| | Type 4 light curtains equipped with solid-state safety outputs with test function | Type 4 light curtains equipped with solid-state safety outputs with test function |
| | 4-wire pressure-sensitive mats or edges | 4-wire pressure-sensitive mats or edges |
| Product certifications | UL, CSA, TÜV, CCC | UL, CSA, TÜV, CCC |

| | | | |
|-------------------------------|--------|-----------------------------|-----------------------------|
| Safety circuits | Number | 3 NO | 3 NO |
| | Type | Instantaneous opening relay | Instantaneous opening relay |
| Module fuse protection | | Internal, electronic | Internal, electronic |
| LEDs | | 6 LEDs | 6 LEDs |
| Power supply | | 24 V ~ | 24 V ~ |

| | | |
|--|-----------|-----------|
| Synchronization time between inputs | Unlimited | Unlimited |
| Input channel voltage | 24 V ~ | 24 V ~ |

| | | | |
|---------------------------|---------------------------------------|------------------|------------------|
| Safety module type | Channels and power supply connected: | | |
| | with removable screw terminals | TM3SAC5R | TM3SAF5R |
| | with removable spring terminal blocks | TM3SAC5RG | TM3SAF5RG |

Pages 3/35



Control of Emergency stop, switches or solid-state output safety light curtains

- Modicon M221 and Modicon M221 Book logic controllers
- Modicon M241 logic controllers
- Modicon M251 logic controllers

Control of Emergency stop, switches, pressure-sensitive mats and edges or solid-state output safety light curtains



| | | |
|--|---|---|
| Maximum achievable safety level | PLd / Category 3 conforming to EN/ISO 13849-1 SILCL2 conforming to EN/IEC 61508 and EN/IEC 62061 | PLe/Category 4 conforming to EN/ISO 13849-1 SILCL3 conforming to EN/IEC 61508 and EN/IEC 62061 |
| Standards (product) | EN/IEC 60947-1 EN/IEC 60947-5-1 | EN/IEC 60947-1 EN/IEC 60947-5-1 |
| Standards (machine assembly) | Emergency stop circuits | Emergency stop circuits |
| | Switches in protective devices | Switches in protective devices |
| | Type 4 light curtains equipped with solid-state safety outputs with test function | Type 4 light curtains equipped with solid-state safety outputs with test function |
| | 4-wire pressure-sensitive mats or edges | 4-wire pressure-sensitive mats or edges |
| Product certifications | UL, CSA, TÜV, CCC | UL, CSA, TÜV, CCC |

| | | | |
|-------------------------------|--------|-----------------------------|-----------------------------|
| Safety circuits | Number | 3 NO | 3 NO |
| | Type | Instantaneous opening relay | Instantaneous opening relay |
| Module fuse protection | | Internal, electronic | Internal, electronic |
| LEDs | | 6 LEDs | 6 LEDs |
| Power supply | | 24 V ~ | 24 V ~ |

| | | |
|--|-----------|--|
| Synchronization time between inputs | Unlimited | Unlimited or 2 s, 4 s (depending on wiring), can be configured in the software |
| Input channel voltage | 24 V ~ | 24 V ~ |

| | | | |
|---------------------------|---------------------------------------|-------------------|------------------|
| Safety module type | Channels and power supply connected: | | |
| | with removable screw terminals | TM3SAFL5R | TM3SAK6R |
| | with removable spring terminal blocks | TM3SAFL5RG | TM3SAK6RG |

Pages 3/35

Expansion modules

Modicon TM3 functional safety modules

(Powered by **Preventa** technology)

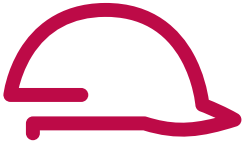

3

Presentation

Modicon TM3 functional safety modules are designed using Preventa technology. They can be used to incorporate machine safety into the overall machine control.

Data acquisition: control of safety products

- Emergency stop button: complementary protection measures
- Monitoring devices used in protective systems to control access to hazardous areas
- Light curtains and safety mats to detect intrusion into hazardous areas

Monitoring and processing

- Modicon TM3 functional safety modules control the input signals from monitoring devices and act as an interface with contactors and variable speed drives, causing the machine to stop.
- Modicon TM3 functional safety modules complement the embedded I/O on M221, M221 Book, M241 and M251 logic controllers.

| Modicon TM3 functional safety modules | Safety system/Performance level reached |
|---------------------------------------|---|
|---------------------------------------|---|

| | |
|--|---------------------------------------|
| For control of emergency stops | Category 3/PLd, SIL2 architecture |
| For control of switches | Category 4/PLe, SIL3 architecture |
| For control of type 4 light curtains | Category 3/PLd, SIL2 architecture |
| For control of pressure-sensitive mats or edges | Category 4/PLe, SIL3 architecture |

- The safety outputs available on the 4 modules are relay type, guided by microprocessor technology.
- Diagnostic utilities use LEDs, found on the module front face. They provide information on the monitoring circuit status.
- The diagnostic information is shared via the TM3 bus.
- The Start button monitoring function is configurable depending on the wiring.

Connections

Equipped, depending on the model, with removable screw or spring-type terminals for connecting the safety channels.

Configuration

Modicon TM3 functional safety modules connect to M221, M221 Book, M241 and M251 logic controllers according to the general rules for the TM3 system: 7 modules max. and 14 modules max. with the use of Modicon TM3 bus expansion system (transmitter and receiver).

Mounting

- Modicon TM3 functional safety modules are mounted on a symmetrical rail.
- For plate or panel mounting, use the **TMAM2** kit.

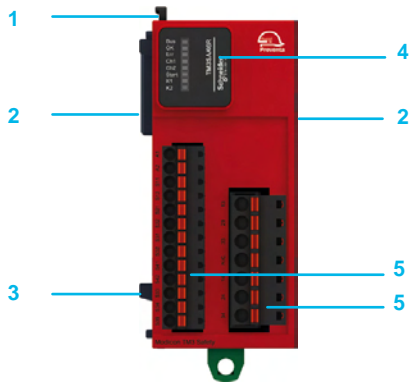

TM3SAC5R



TM3SAC5RG



TM3SAF5R



TM3SAF5RG



TM3SAFL5R



TM3SAFL5RG



TM3SAK6R



TM3SAK6RG

Description

Modicon TM3 functional safety modules

- 1 Adjacent module locking latch.
- 2 TM3 bus connectors (one on each side). These are designed to provide continuity of the link between connected modules.
- 3 symmetrical rail locking clip.
- 4 Display block (6 LEDs - green, red) for the module channels and diagnostics.
- 5 Removable spring or screw-type terminal blocks (depending on the model) for connecting the safety channels and the power supply.

References

| Designation | Maximum achievable safety level | Term. block for input conn. (1) | Reference | Weight kg/lb |
|---|---|---------------------------------|-------------------|-----------------|
| 24 V $\overline{\text{---}}$ power supply | | | | |
| Functional Safety modules for control of <input type="checkbox"/> emergency stops <input type="checkbox"/> switches | PLd/Category 3 conforming to EN/ISO 13849-1 SILCL2 conforming to EN/IEC 61508 and EN/IEC 62061 | screw | TM3SAC5R | 0.190/ 0.420 |
| | | spring | TM3SAC5RG | 0.190/ 0.420 |
| Functional Safety modules for control of <input type="checkbox"/> emergency stops <input type="checkbox"/> switches | PLe/Category 4 conforming to EN/ISO 13849-1 SILCL3 conforming to EN/IEC 61508 and EN/IEC 62061 | screw | TM3SAF5R | 0.190/ 0.420 |
| | | spring | TM3SAF5RG | 0.190/ 0.420 |
| Functional Safety modules for control of <input type="checkbox"/> emergency stops <input type="checkbox"/> switches <input type="checkbox"/> safety light curtains with solid-state outputs | PLd / Category 3 conforming to EN/ISO 13849-1 SILCL2 conforming to EN/IEC 61508 and EN/IEC 62061 | screw | TM3SAFL5R | 0.190/ 0.420 |
| | | spring | TM3SAFL5RG | 0.190/ 0.420 |
| Functional Safety modules for control of <input type="checkbox"/> emergency stops <input type="checkbox"/> switches <input type="checkbox"/> safety light curtains with solid-state outputs <input type="checkbox"/> pressure-sensitive mats or edges | PLe/Category 4 conforming to EN/ISO 13849-1 SILCL3 conforming to EN/IEC 61508 and EN/IEC 62061 | screw | TM3SAK6R | 0.190/ 0.420 |
| | | spring | TM3SAK6RG | 0.190/ 0.420 |
| Separate parts | | | | |
| Designation | Description | Reference | Weight kg/lb | |
| Mounting kit Sold in lots of 10 | For mounting Functional Safety modules on a plate or panel | TMAM2 | 0.065/ 0.143 | |

(1) Removable terminal blocks equipped with screw terminals or spring terminals, supplied with the controller.

3

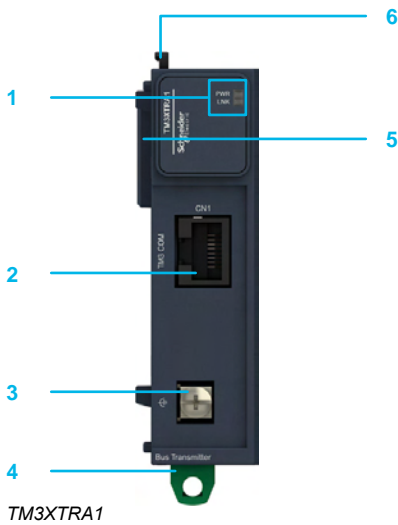

TM3XTRA1

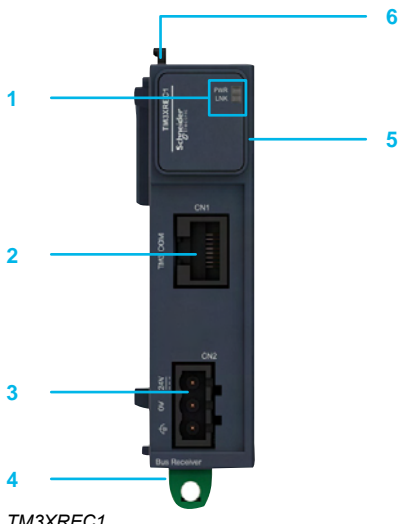

TM3XREC1

Presentation

Modicon TM3 transmitter and receiver modules can be used to:

- increase from 7 to 14 the number of I/O expansion modules that can be connected to an M2●● logic controller
- locate Modicon TM3 expansion modules remotely, up to 5 m (16.404 ft.) away

The transmitter and receiver modules are physically linked by a **VDIP184546●●●** bus expansion cable.

Mounting

- TM3 bus expansion modules are mounted on a \perp symmetrical rail.
- For plate or panel mounting, use the **TMAM2** kit.

Description

TM3XTRA1 transmitter module

- 1 Block with 2 LEDs displaying the communication status and power supply status.
- 2 RJ 45 connector for connecting the **VDIP184546●●●** bus expansion cable.
- 3 Screw terminal for the functional ground (FG) connection.
- 4 \perp symmetrical rail locking clip.
- 5 TM3 bus connector providing continuity of the link with the connected module.
- 6 Adjacent module locking latch.

TM3XREC1 receiver module

- 1 Block with 2 LEDs displaying the communication status and power supply status.
- 2 RJ 45 connector for connecting the **VDIP184546●●●** bus expansion cable.
- 3 Screw terminal block for connecting the power supply.
- 4 \perp symmetrical rail locking clip.
- 5 TM3 bus connector providing continuity of the link with the connected module.
- 6 Adjacent module locking latch.

Expansion modules

Modicon TM3 bus expansion system

Transmitter module and receiver module



TM3XTRA1



TM3XREC1

References

Modicon TM3 bus expansion system

| Designation | Characteristics | Reference | Weight kg/ lb |
|---------------------------|--|------------------------|---------------------|
| Transmitter module | Data transmission module Power supply: using the TM3 bus | TM3XTRA1 | 0.065/ 0.143 |
| Receiver module | Data reception module Power supply: 24 V $\overline{\text{DC}}$ (with external power supply) | TM3XREC1 (1) | 0.075/ 0.165 |

Cordsets

| Designation | Used for | Length m/ ft | Reference | Weight kg/ lb |
|--|--|--------------------|---|---------------------|
| Shielded category 5E TM3 bus expansion cables | TM3 bus expansion by linking transmitter and receiver modules Equipped with an RJ 45 connector at each end | 0.5/ 1.64 | VDIP184546005 | – |
| | | 1/ 3.28 | VDIP184546010 | – |
| | | 2/ 6.56 | VDIP184546020 | – |
| | | 3/ 9.84 | VDIP184546030 | – |
| | | 5/ 16.40 | VDIP184546050 | – |
| Functional ground cable | Functional ground for the TM3XTRA1 transmitter module | 0.12/ 0.39 | Cable supplied with the TM3XTRA1 transmitter module | – |

Spare parts

| Designation | Description | Unit reference | Weight kg/ lb |
|---|---|-------------------|---------------------|
| Mounting kit Sold in lots of 10 | For mounting bus expansion modules on a plate or panel | TMAM2 | 0.065/ 0.143 |
| Set of terminal blocks for connecting the power supply | 8 removable terminal blocks with screw terminals | TMAT2PSET | 0.127/ 0.280 |
| | 8 removable terminal blocks with spring terminals | TMAT2PSETG | 0.127/ 0.280 |

(1) The TM3XREC1 module is supplied with a removable screw terminal block for connecting the power supply.

Expansion modules

Modicon TM5 compact blocks
for Modicon M258 logic controller and Modicon LMC058 motion controller

| | |
|---------------------|--|
| Applications | Modicon TM5 compact block Compatibility |
|---------------------|--|

| | | |
|---|---------------|---------------|
| 20 I/O | 36 I/O | 42 I/O |
| Modicon M258 logic controller Modicon LMC058 motion controller | | |



Channel connection

With removable spring terminal blocks (supplied)

| | |
|-----------------------|---------------------------|
| Digital inputs | Number |
| | Nominal input voltage |
| | IEC/EN 61131-2 conformity |
| | Type of signal (1) |
| | Type of wiring |
| | Limit values |
| | Nominal input current |
| | Input impedance |
| | State 0 |
| | State 1 |

| | | |
|------------------|------------------|------------------|
| 12 | 24 | 24 |
| 24 V ~ | 24 V ~ | 24 V ~ |
| Type 1 | Type 1 | Type 1 |
| Sink | Sink | Sink |
| 3-wire | 1-wire | 1-wire |
| 20.4... 28.8 V ~ | 20.4... 28.8 V ~ | 20.4... 28.8 V ~ |
| 3.75 mA | 3.75 mA | 3.75 mA |
| 6.4 kΩ | 6.4 kΩ | 6.4 kΩ |
| 5 V max. ~ | 5 V max. ~ | 5 V max. ~ |
| 15 V min. ~ | 15 V min. ~ | 15 V min. ~ |

| | |
|------------------------|---------------------------------------|
| Digital outputs | Number |
| | Nominal output voltage |
| | Output current per channel |
| | Output current per group of channels |
| | Type of signal (1) |
| | Type of wiring |
| | Limit values |
| | Short-circuit and overload protection |

| | | |
|----------------------|-----------------------------------|-----------------------|
| 8, transistor | 12, relays with NO contact | 18, transistor |
| 24 V ~ | 24 V ~ | 24 V ~ |
| 0.5 A | 0.5 A | 0.5 A |
| 1 A max. | 5 A max. | 2 A max. |
| Source | Source | Source |
| 3-wire | 1-, 2- or 3-wire | 2-wire |
| 20.4... 28.8 V ~ | 20.4... 28.8 V ~ | 20.4... 28.8 V ~ |
| Yes | Yes | Yes |

| | |
|----------------------|---|
| Analog inputs | Number |
| | Type |
| | Range |
| | Resolution |
| | Sampling period without filtering with filtering |

| | | | |
|---|------------------|-----------------------|---|
| 4 | 8 | 8 | 8 |
| Voltage/current | Voltage | Current | 4 Voltage + 4 current |
| - 10... + 10 Vdc 0... 20 mA/4... 20 mA | - 10... + 10 Vdc | 0... 20 mA/4... 20 mA | Voltage : - 10... + 10 Vdc Current : 0... 20 mA/4... 20 mA |
| 12 bits | 11 bits + sign | 12 bits | Voltage: 11 bits + sign Current: 12 bits |
| 300 μs 1 ms | — 50 ms | — 50 ms | — 50 ms |

| | |
|-----------------------|---------------|
| Analog outputs | Number |
| | Type |
| | Range |
| | Resolution |
| | Response time |

| | | | |
|--------------------------------|--------------------------------|--------------------------------|--|
| 2 | 8 | 8 | 8 |
| Voltage/current | Voltage | Current | 4 Voltage + 4 current |
| - 10... + 10 Vdc 0... 20 mA | - 10... + 10 Vdc | 0... 20 mA | Voltage : - 10... + 10 Vdc Current : 0... 20 mA |
| 12 bits | 11 bits + sign | 12 bits | Voltage: 11 bits + sign Current: 12 bits |
| 1 ms max. | 20 ms max. 5 ms per channel | 20 ms max. 5 ms per channel | 20 ms max. 5 ms per channel |

| | |
|---------------------|------------------------|
| Power supply | Channel-to-channel |
| | Between channel groups |
| | Channel-to-bus |

| | | | |
|--------------|--------------|--------------|--------------|
| Internal | Internal | Internal | Internal |
| Non-isolated | Non-isolated | Non-isolated | Non-isolated |
| — | — | — | — |
| 500 V ~ RMS | 500 V ~ RMS | 500 V ~ RMS | 500 V ~ RMS |

| |
|--|
| Type of Modicon TM5 compact block |
|--|

| | | |
|------------------|-------------------|-------------------|
| TM5C12D8T | TM5C24D12R | TM5C24D18T |
|------------------|-------------------|-------------------|

| |
|-------------|
| Page |
|-------------|

| |
|------|
| 3/41 |
|------|

(1) Source output: PNP output. Sink output: NPN output.

| | |
|---|---------------|
| 24 I/O | 16 I/O |
| Modicon M258 logic controller Modicon LMC058 motion controller | |



With removable spring terminal blocks (supplied)

| |
|------------------|
| 12 |
| 24 V ~ |
| Type 1 |
| Sink |
| 2-wire |
| 20.4... 28.8 V ~ |
| 3.75 mA |
| 6.4 kΩ |
| 5 V max. ~ |
| 15 V min. ~ |

| |
|----------------------|
| 6, transistor |
| 24 V ~ |
| 0.5 A |
| 2 A max. |
| Source |
| 2-wire |
| 20.4... 28.8 V ~ |
| Yes |

| | | | |
|---|------------------|-----------------------|---|
| 4 | 8 | 8 | 8 |
| Voltage/current | Voltage | Current | 4 Voltage + 4 current |
| - 10... + 10 Vdc 0... 20 mA/4... 20 mA | - 10... + 10 Vdc | 0... 20 mA/4... 20 mA | Voltage : - 10... + 10 Vdc Current : 0... 20 mA/4... 20 mA |
| 12 bits | 11 bits + sign | 12 bits | Voltage: 11 bits + sign Current: 12 bits |
| 300 μs 1 ms | — 50 ms | — 50 ms | — 50 ms |

| | | | |
|--------------------------------|--------------------------------|--------------------------------|--|
| 2 | 8 | 8 | 8 |
| Voltage/current | Voltage | Current | 4 Voltage + 4 current |
| - 10... + 10 Vdc 0... 20 mA | - 10... + 10 Vdc | 0... 20 mA | Voltage : - 10... + 10 Vdc Current : 0... 20 mA |
| 12 bits | 11 bits + sign | 12 bits | Voltage: 11 bits + sign Current: 12 bits |
| 1 ms max. | 20 ms max. 5 ms per channel | 20 ms max. 5 ms per channel | 20 ms max. 5 ms per channel |

| | | | |
|--------------|--------------|--------------|--------------|
| Internal | Internal | Internal | Internal |
| Non-isolated | Non-isolated | Non-isolated | Non-isolated |
| — | — | — | — |
| 500 V ~ RMS | 500 V ~ RMS | 500 V ~ RMS | 500 V ~ RMS |

| | | | |
|--------------------|--------------------|--------------------|---------------------|
| TM5C12D6T6L | TM5CAI8O8VL | TM5CAI8O8CL | TM5CAI8O8CVL |
|--------------------|--------------------|--------------------|---------------------|

| |
|------|
| 3/41 |
|------|

Expansion modules

Modicon TM5 compact blocks for Modicon M258 logic controller and Modicon LMC058 motion controller

Presentation

Modicon **TM5C●●●●●●●●** compact blocks offer a low-cost solution for expanding digital and/or analogue I/O control system configurations. They consist of a block containing the circuit boards, the bus bases, and the **TM5ACTB12** removable terminal blocks.

They complement the embedded I/O in the various M258 controllers and LMC058 motion controllers and represent a cost-effective way to create configurations requiring a large number of digital or analogue channels.

The **TM5C●●●●●●●●** I/O compact block offer consists of:

- A 24 V $\overline{\text{V}}$ digital I/O compact block, with 12 sink inputs and 8 transistor outputs
- A 24 V $\overline{\text{V}}$ digital I/O compact block, with 24 sink inputs and 12 relay outputs
- A 24 V $\overline{\text{V}}$ digital I/O compact block, with 24 sink inputs and 18 transistor outputs
- A 24 V $\overline{\text{V}}$ mixed I/O compact block, with 12 sink digital inputs and 4 analogue inputs, and 6 transistor digital outputs and 2 analogue outputs
- 3 x 24 V $\overline{\text{V}}$ analogue I/O compact block:
 - a block with 8 voltage I/O
 - a block with 8 current I/O
 - a block with 4 voltage I/O + 4 current I/O.

Regardless of which compact block is chosen, the format is the same and corresponds to five I/O expansion modules.

TM5 compact blocks are connected to the TM5 expansion bus on M258 controllers and LMC058 motion controllers.

The advantage of these blocks is their compact size, ease of wiring and, depending on the reference, the option of combining different types of channel.

Description

TM5 compact blocks comprise:

- 1 On each side of the base, a bus expansion connection for the link with the previous controller or block
- 2 Two mechanical locking clips for mounting/dismounting on a symmetrical rail
- 3 Five LED display blocks for the channels and compact block diagnostics
- 4 Five slots for the plain text cover holder (label-holder)
- 5 Five removable spring terminal blocks, each with locking clip and slots for coloured identifiers

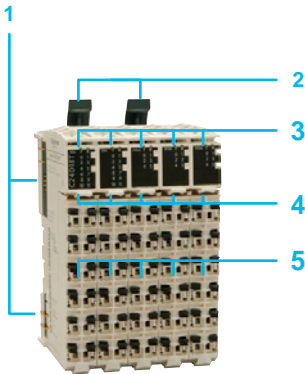

Expansion modules

Modicon TM5 compact blocks
for Modicon M258 logic controller and Modicon LMC058
motion controller

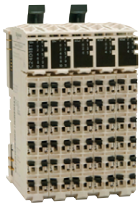

TM5C12D8T

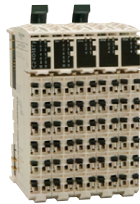

TM5C24D12R



TM5C24D18T

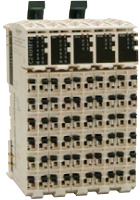

TM5C12D6T6L

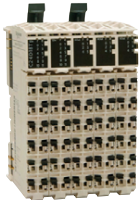

TM5CAI808VL

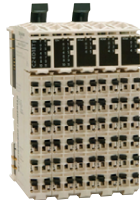

TM5CAI808CL

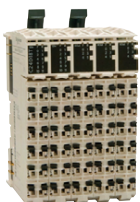

TM5CAI808CVL

References

| Number of I/O | Inputs | Outputs (1) | Reference | Weight kg/ lb |
|---|--|---|----------------|---------------------|
| TM5 I/O digital compact blocks | | | | |
| 20 I/O | 12 digital inputs, 24 V $\overline{\text{---}}$, Sink, 3-wire | 8 transistor digital outputs, 3-wire, 24 V $\overline{\text{---}}$, Source, 0.5 A | TM5C12D8T | 0.037/ 0.082 |
| 36 I/O | 24 digital inputs, 24 V $\overline{\text{---}}$, Sink, 1-wire, 0.5 A max | 12 digital outputs, 5 A relay, with NO contact, 30 V $\overline{\text{---}}$ /230 V \sim | TM5C24D12R | 0.037/ 0.082 |
| 42 I/O | 24 digital inputs, 24 V $\overline{\text{---}}$, Sink, 1-wire | 18 transistor digital outputs, 24 V $\overline{\text{---}}$, Source, 0.5 A, 2-wire | TM5C24D18T | 0.037/ 0.082 |
| TM5 I/O digital/analogue compact blocks | | | | |
| 24 I/O | 12 digital inputs, 24 V $\overline{\text{---}}$, Sink, 2-wire 4 analogue inputs - 10...+ 10 V, 0...20 mA, 4...20 mA, resolution 12 bits | 6 transistor digital outputs, 2-wire, 24 V $\overline{\text{---}}$, Source, 0.5 A 2 analogue outputs, - 10...+ 10 V, 0...20 mA, resolution 12 bits | TM5C12D6T6L | 0.037/ 0.082 |
| TM5 I/O analogue compact blocks | | | | |
| 16 I/O | 8 analogue voltage inputs - 10...+ 10 Vdc Resolution 11 bits + sign | 8 analogue voltage outputs - 10...+ 10 Vdc Resolution 11 bits + sign | TM5CAI808VL | 0.037/ 0.082 |
| | 8 analogue current inputs 0...20 mA/4...20 mA Resolution 12 bits | 8 analogue current outputs 0...20 mA Resolution 12 bits | TM5CAI808CL | 0.037/ 0.082 |
| | 8 analogue inputs: <input type="checkbox"/> 4 voltage inputs - 10...+ 10 Vdc <input type="checkbox"/> 4 current inputs 0...20 mA/4...20 mA Resolution <input type="checkbox"/> voltage: 11 bits + sign <input type="checkbox"/> current : 12 bits | 8 analogue outputs: <input type="checkbox"/> 4 voltage outputs - 10...+ 10 Vdc <input type="checkbox"/> + 4 current outputs 0...20 mA Resolution <input type="checkbox"/> voltage: 11 bits + sign <input type="checkbox"/> current : 12 bits | TM5CAI808CVL | 0.037/ 0.082 |
| Terminal blocks | | | | |
| Use | Description | Sold in lots of | Unit reference | Weight kg/ lb |
| For I/O compact blocks, 24 V $\overline{\text{---}}$ power supply | 12 spring terminals | 1 | TM5ACTB12 | 0.020/ 0.044 |
| | | 10 | TM5ACTB1210 | 0.200/ 0.441 |
| Accessories | | | | |
| See page 3/62 | | | | |

(1) Source output: PNP output, sink output: NPN output.

Expansion modules

Modicon TM5 Digital modules
and Modicon TM5 Digital/Analog module
for Modicon M258 logic controller and Modicon LMC058
motion controller

Applications Type of expansion module

Compatibility

2 to 16 digital input channels

Modicon M258 logic controller, Modicon LMC058 motion controller



With removable spring terminal blocks (to be ordered separately)

| | 2 | 4 | 6 | 12 | 16 | 2 | 4 | 6 |
|---------------------------|------------------|---|-------------|--------|-----------------|------------------|---|------------------|
| Number | 2 | 4 | 6 | 12 | 16 | 2 | 4 | 6 |
| Nominal input voltage | 24 V ~ | | | | | 100/240 V ~ | | |
| IEC/EN 61131-2 conformity | Type 1 | | | | | Type 1 | | |
| Type of signal (1) | Sink | | | | | - | | |
| Type of wiring | 1-, 2- or 3-wire | | 1 or 2-wire | 1-wire | | 1-, 2- or 3-wire | | 1 or 2-wire |
| Limit values | ~ 20.4...28.8 V | | | | | ~ 100...240 V | | |
| Nominal input current | 3.75 mA | | 2.68 mA | | 5 mA at ~ 100 V | 11 mA at ~ 240 V | | 10 mA at ~ 120 V |
| Input impedance | 6.4 kΩ | | 8.9 kΩ | | - | | | - |
| State 0 | ~ 5 V max. | | | | | - | | |
| State 1 | ~ 15 V min. | | | | | - | | |

Channel connection

Digital inputs

Number

Nominal input voltage

IEC/EN 61131-2 conformity

Type of signal (1)

Type of wiring

Limit values

Nominal input current

Input impedance

State 0

State 1

Digital outputs

Number

Nominal output voltage

Output current per channel

Output current per group of channels

Type of signal (1)

Type of wiring

Limit values

Short-circuit and overload protection

Analog inputs

Number

Type

Range

Resolution

Sampling period

without filtering

with filtering

Analog outputs

Number

Type

Range

Resolution

Response time

Type of electronic expansion module

| | | | | | | | |
|-----------|-----------|-----------|------------|------------|-----------|-----------|-----------|
| TM5 SDI2D | TM5 SDI4D | TM5 SDI6D | TM5 SDI12D | TM5 SDI16D | TM5 SDI2A | TM5 SDI4A | TM5 SDI6U |
|-----------|-----------|-----------|------------|------------|-----------|-----------|-----------|

Associated bus base (2)

| | |
|----------------------|-----------|
| TM5ACBM11, TM5ACBM15 | TM5ACBM12 |
|----------------------|-----------|

Associated terminal block (2)

| | | | |
|----------------------|------------|------------|-----------|
| TM5ACTB06, TM5ACTB12 | TM5 ACTB12 | TM5 ACTB16 | TM5ACTB32 |
|----------------------|------------|------------|-----------|

Pages

| | |
|------|------|
| 3/45 | 3/47 |
|------|------|

(1) Source output: PNP output, sink output: NPN output.
(2) to be ordered separately.

4 digital input channels and 1 analog input channel 2 digital output channels and 1 analog output channel

8 digital input channels 4 transistor output channels

2 to 16 transistor output channels

2 transistor output channels

2 to 4 relay output channels

Modicon M258 logic controller, Modicon LMC058 motion controller



With removable spring terminal blocks (to be ordered separately)

| | 4 | 8 |
|-----------------------|-----------------|---------|
| Number | 4 | 8 |
| Nominal input voltage | 24 V ~ | |
| Type 1 | Type 1 | |
| Sink | Sink | |
| 1-wire | 1-wire | |
| Limit values | ~ 20.4...28.8 V | |
| Nominal input current | 3.3 mA | 3.75 mA |
| Input impedance | 7.2 kΩ | 6.4 kΩ |
| State 0 | ~ 5 V max. | |
| State 1 | ~ 15 V min. | |

| | 2 | 4 | 2 | 4 | 4 | 6 | 8 | 12 | 16 | 2 | 2 | 4 |
|---------------------------------------|-----------------|----------|-----------------|----------|------------------|----------|-----------------|----------|-----------------|-------------|-------------------|---------------|
| Number | 2 | 4 | 2 | 4 | 4 | 6 | 8 | 12 | 16 | 2 | 2 | 4 |
| Nominal output voltage | 24 V ~ | | | | | | | | | 100/240 V ~ | ~ 30/~ 230 V | |
| Output current per channel | 0.5 A | 0.5 A | 0.5 A | 0.5 A | 2 A | 0.5 A | 2 A | 0.5 A | 0.5 A | 1 A | 5 A | 10 A max. |
| Output current per group of channels | 1 A max. | 2 A max. | 1 A max. | 2 A max. | 4 A max. | 3 A max. | 8 A max. | 6 A max. | 6 A max. | 1 A | 10 A max. | |
| Type of signal (1) | Source | | Source | | Source | | Source | | Source | | Solid state relay | Relay |
| Type of wiring | 1-wire | | 1-wire | | 1-, 2- or 3-wire | | 1 or 2-wire | | 1-wire | | 3-wire | NO/NC contact |
| Limit values | ~ 20.4...28.8 V | | ~ 20.4...28.8 V | | ~ 20.4...28.8 V | | ~ 20.4...28.8 V | | ~ 20.4...28.8 V | | ~ 80...264 V | ~ 24...36 V |
| Short-circuit and overload protection | Yes | | Yes | | Yes | | Yes | | Yes | | Yes | No |

1

Voltage/current

- 10...+ 10 Vdc

0...20 mA/4...20 mA

12 bits + sign

400 ms

1 ms max.

1

Voltage/current

- 10...+ 10 Vdc

0...20 mA

12 bits

1 ms max.

| | | | | | | | | | | | | |
|-------------|-------------|-----------|-----------|------------|-----------|------------|------------|------------|-----------|-----------|-----------|------------|
| TM5 SMM6D2L | TM5 SDM12DT | TM5 SDO2T | TM5S DO4T | TM5 SDO4TA | TM5 SDO6T | TM5 SDO8TA | TM5 SDO12T | TM5 SDO16T | TM5 SDO2S | TM5 SDO2R | TM5 SDO4R | TM5 SDO4R4 |
|-------------|-------------|-----------|-----------|------------|-----------|------------|------------|------------|-----------|-----------|-----------|------------|

Associated bus base (2)

| | |
|----------------------|-----------|
| TM5ACBM11, TM5ACBM15 | TM5ACBM12 |
|----------------------|-----------|

Associated terminal block (2)

| | | | | |
|-----------|----------------------|-----------|------------|-----------|
| TM5ACTB12 | TM5ACTB06, TM5ACTB12 | TM5ACTB12 | TM5 ACTB16 | TM5ACTB32 |
|-----------|----------------------|-----------|------------|-----------|

Pages

| | |
|------|------|
| 3/45 | 3/47 |
|------|------|

(1) Source output: PNP output, sink output: NPN output.
(2) to be ordered separately.

Expansion modules

Modicon TM5 Digital modules and Modicon TM5 Digital/Analog module for Modicon M258 logic controller and Modicon LMC058 motion controller

3

Presentation

The **TM5S●●●●** digital module offer consists of:

- Thirteen input, mixed I/O and output electronic modules (sensor and preactuator 24 V $\overline{\text{DC}}$ power supply): **TM5SD●●●●**
- One Digital/Analog mixed I/O electronic module: **TM5SMM6D2L**.

They complement the embedded I/O in the various M258 logic controllers and LMC058 motion controllers. They are used to adapt to the application requirements as closely as possible to reduce the installation and wiring costs.

Each digital expansion module consists of three parts to be ordered separately (1):

- An I/O electronic module
- A bus base
- A terminal block

These modules can be mechanically assembled before mounting on a symmetrical rail.

These modules offer the following advantages:

- Removable terminal
- Spring terminals which can be used for quick, tool-free connection of the sensors and preactuators in addition, the quality of the spring terminals avoids the need for periodic retightening
- Hot swapping

The digital modules offer includes:

- Five 24 V $\overline{\text{DC}}$ digital input modules with 2, 4, 6, 12 or 16 sink inputs
- One 24 V $\overline{\text{DC}}$ digital mixed I/O electronic module, with 8 sink inputs and 4 source transistor outputs
- Seven digital output electronic modules with 2, 4, 6, 12 or 16 source transistor outputs

The digital/analog module offer includes:

- one mixed I/O electronic module with four 24 V $\overline{\text{DC}}$ digital inputs and one voltage/current analog input, two 24 V digital outputs and one voltage/current analog output.

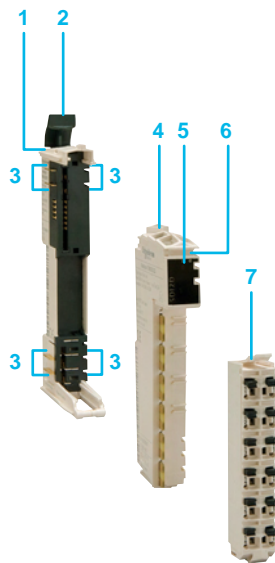

Description

TM5SD●●●● digital modules and digital/analog **TM5SMM6D2L** module comprise:

- 1 A bus base
- 2 A mechanical locking lever for mounting/dismounting on a symmetrical rail
- 3 On each side of the base, a bus expansion connection for the link with the previous controller or module
- 4 A digital input, I/O or output electronic module
- 5 A channel and module diagnostics LED display block
- 6 A slot for labelling (label-holder)
- 7 A removable spring terminal block with locking lever and slots for coloured identifiers

(1) Also sold in kits, see page 3/63

Expansion modules

Modicon TM5 Digital modules
and Modicon TM5 Digital/Analog module
for Modicon M258 logic controller and Modicon LMC058
motion controller



TM5SD●●●



TM5SMM6D2L



TM5ACBM●●



TM5ACTB●●

References

Digital input electronic modules

| Voltage | Number and type of channels (1) | Reference | Weight kg/ lb |
|--|------------------------------------|-----------|---------------------|
| 24 V $\overline{\text{---}}$ inputs | 2 sink inputs | TM5SDI2D | 0.025/ 0.055 |
| | 4 sink inputs | TM5SDI4D | 0.025/ 0.055 |
| | 6 sink inputs | TM5SDI6D | 0.025/ 0.055 |
| | 12 sink inputs | TM5SDI12D | 0.025/ 0.055 |
| | 16 sink inputs | TM5SDI16D | 0.025/ 0.055 |

Digital mixed inputs/outputs electronic module

| | | | |
|--|--|------------|-----------------|
| 24 V $\overline{\text{---}}$ inputs/outputs | 8 sink inputs, 4 source transistor outputs | TM5SDM12DT | 0.025/ 0.055 |
|--|--|------------|-----------------|

Digital output electronic modules

| | | | | |
|---|------------------------------|------------------------------------|-----------------|-----------------|
| 24 V $\overline{\text{---}}$ outputs | 2 source transistor outputs | 0.5 A per channel | TM5SDO2T | 0.025/ 0.055 |
| | 4 source transistor outputs | 0.5 A per channel | TM5SDO4T | 0.025/ 0.055 |
| | 4 source transistor outputs | 2 A per channel, 4 A per module | TM5SDO4TA | 0.025/ 0.055 |
| | 6 source transistor outputs | 0.5 A per channel | TM5SDO6T | 0.025/ 0.055 |
| | 8 source transistor outputs | 2 A per channel | TM5SDO8TA | 0.025/ 0.055 |
| | 12 source transistor outputs | 0.5 A per channel | TM5SDO12T | 0.025/ 0.055 |
| 16 source transistor outputs | 0.5 A per channel | TM5SDO16T | 0.025/ 0.055 | |

Digital/Analog mixed inputs/outputs electronic module

| | | | | |
|--|-----------------------------|--------------------------------------|------------|-----------------|
| 24 V $\overline{\text{---}}$ inputs/outputs | 4 sink digital inputs | – | TM5SMM6D2L | 0.025/ 0.055 |
| | 1 analog input | - 10... + 10Vdc, 0...20 mA/4...20 mA | | |
| | 2 source transistor outputs | 0.5 A per channel | | |
| | 1 analog output | 0...20 mA | | |

Bus bases

| Power supply | Characteristics | Sold in lots of | Unit reference | Weight kg/ lb |
|------------------------------|-----------------|--------------------|-------------------|---------------------|
| 24 V $\overline{\text{---}}$ | – | 1 | TM5ACBM11 | 0.020/ 0.044 |
| | | 10 | TM5ACBM1110 | 0.200/ 0.441 |
| | Address setting | 1 | TM5ACBM15 | 0.020/ 0.044 |
| | | 10 | TM5ACBM1510 | 0.200/ 0.441 |

Terminal blocks

| Use | Description | Sold in lots of | Unit reference | Weight kg/ lb |
|---|-------------|--------------------|-------------------|---------------------|
| For electronic modules, 24 V $\overline{\text{---}}$ power supply | 6 contacts | 1 | TM5ACTB06 | 0.016/ 0.035 |
| | | 10 | TM5ACTB0610 | 0.160/ 0.305 |
| | 12 contacts | 1 | TM5ACTB12 | 0.020/ 0.044 |
| | | 10 | TM5ACTB1210 | 0.200/ 0.441 |
| 16 contacts | 1 | TM5ACTB16 | 0.020/ 0.044 | |

Accessories

See page 3/62

Digital I/O expansion module kits

See page 3/63

(1) Source output: PNP output, sink output: NPN output.

Expansion modules

Modicon TM5 Digital modules

for Modicon M258 logic controller and Modicon LMC058 motion controller

3

Presentation

The **TM5SD●●●** digital module offer consists of six input and output electronic modules (sensor and preactuator 100/240 V ~ power supply). They complement the embedded I/O in the various M258 controllers and LMC058 motion controllers. They are used to adapt to the application requirements as closely as possible to reduce the installation and wiring costs.

Each digital module consists of three parts to be ordered separately (1):

- An I/O electronic module
- A bus base
- A terminal block

These modules can be mechanically assembled before mounting on a symmetrical rail.

These modules offer the following advantages:

- Removable terminal
- Spring terminals which can be used for quick, tool-free connection of the sensors and preactuators in addition, the quality of the spring terminals avoids the need for periodic retightening
- Hot swapping

The digital modules offer includes:

- Two 100/240 V ~ digital input electronic modules, with 2 or 4 inputs
- A 100/120 V ~ digital input electronic module, with 6 inputs
- A 100/240 V ~ digital output electronic modules, with 2 outputs
- Two 30 V ~/230 V ~ digital output electronic modules, with 2 or 4 relay outputs

Description

TM5SD●●● digital modules comprise:

- 1 A bus base
- 2 A mechanical locking lever for mounting/dismounting on a symmetrical rail
- 3 On each side of the base, a bus expansion connection for the link with the previous controller or module
- 4 A digital input or output electronic module
- 5 A channel and module diagnostics LED display block
- 6 A slot for labelling (label-holder)
- 7 A removable spring terminal block with locking lever and slots for coloured identifiers

(1) Also sold in kit, see page 3/63

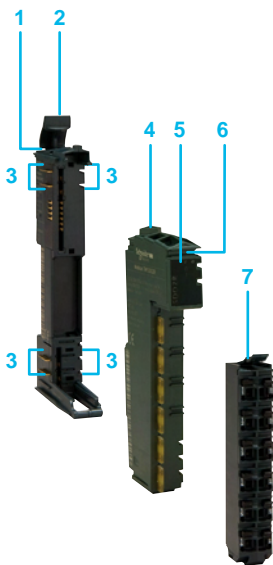

Expansion modules

Modicon TM5 Digital modules

for Modicon M258 logic controller and Modicon LMC058 motion controller



TM5SDI●●



TM5SDO●●



TM5ACBM●●



TM5ACTB●●

References

Multivoltage digital input electronic modules

| Voltage | Number and type of channels (1) | Sold in lots of | Unit reference | Weight kg/lb |
|-----------------------|---------------------------------|-----------------|----------------|-----------------|
| 100/240 V ~ inputs | 2 inputs | 1 | TM5SDI2A | 0.025/ 0.055 |
| | 4 inputs | 1 | TM5SDI4A | 0.025/ 0.055 |
| 100/120 V ~ inputs | 6 inputs | 1 | TM5SDI6U | 0.025/ 0.055 |

Digital output electronic modules

| | | | | |
|-----------------------------|---|---|-----------|-----------------|
| 100/240 V ~ outputs | 2 x 1 A transistor outputs | 1 | TM5SDO2S | 0.025/ 0.055 |
| 30 V ---/230 V ~ outputs | 2 x 5 A relay outputs, NO/NC contact | 1 | TM5SDO2R | 0.025/ 0.055 |
| | 4 x 5 A relay outputs, NO/NC contact | 1 | TM5SDO4R | 0.025/ 0.055 |
| | | 4 | TM5SDO4R4 | 0.100/ 0.220 |

Bus bases

| Power supply | Characteristics | Sold in lots of | Unit reference | Weight kg |
|--------------|-----------------|-----------------|----------------|-----------------|
| ~ 240 V | - | 1 | TM5ACBM12 | 0.020/ 0.044 |
| | | 10 | TM5ACBM1210 | 0.200/ 0.440 |

Terminal blocks

| Use | Description | Sold in lots of | Unit reference | Weight kg |
|--|-------------|-----------------|----------------|-----------------|
| For digital I/O electronic module, 240 V ~ power supply | 12 contacts | 1 | TM5ACTB32 | 0.025/ 0.055 |
| | | 10 | TM5ACTB3210 | 0.250/ 0.550 |

Accessories

See page 3/62

Digital I/O expansion module kit

See page 3/63

(1) Source output: PNP output, sink output: NPN output.

Expansion modules

Modicon TM5 common distribution modules for Modicon M258 logic controller and Modicon LMC058 motion controller

3

Presentation

TM5SP●●● common distribution modules make cabling more flexible by “branching” the various voltages needed to power the I/O expansion modules used.

Each common distribution module consists of three parts to be ordered separately:

- A common distribution electronic module
- A bus base
- A terminal block to be chosen according to the number of terminals

These modules can be mechanically assembled before mounting on a symmetrical rail.

These modules offer the following advantages:

- Removable terminal
- Spring terminals which can be used for quick, tool-free connection of the sensors and preactuators in addition, the quality of the spring terminals avoids the need for periodic retightening
- Hot swapping

The power supply common modules offer includes four common distribution electronic modules which have a removable fuse.

This offer is completed by a non-functioning dummy module **TM5SD000** which can be used to:

- Increase the flexibility in managing the various options for an installation: machine with or without temperature sensors for example.
- Reserve a physical slot and a logical address on the backplane bus, for adding a functioning module at a later date: application-specific I/O expansion for example.

Description

TM5SP●●● common distribution modules comprise:

- 1 A bus base
- 2 A mechanical locking lever for mounting/dismounting on a symmetrical rail
- 3 On each side of the base, a bus expansion connection for the link with the previous controller or module
- 4 A common distribution electronic module
- 5 A channel and module diagnostics LED display block
- 6 A slot for labelling (label-holder)
- 7 A removable spring terminal block with locking lever and slots for coloured identifiers

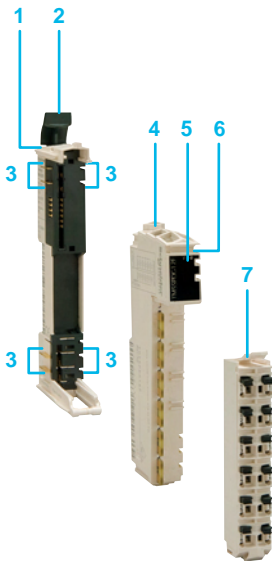

Expansion modules

Modicon TM5 common distribution modules for Modicon M258 logic controller and Modicon LMC058 motion controller



TM5SPDG●●●



TM5ACBM●●



TM5ACTB●●

References

Common distribution electronic modules (1)

| Power supply type | Characteristics | Reference | Weight kg/lb |
|------------------------------|---|-------------|--------------|
| 24 V $\overline{\text{---}}$ | 12 common x 0 Vdc with 1 fuse | TM5SPDG12F | 0.025/0.055 |
| | 12 common x 24 Vdc with 1 fuse | TM5SPDD12F | 0.025/0.055 |
| | 5 common x 0 Vdc 5 common x 24 Vdc with 1 fuse | TM5SPDG5D4F | 0.025/0.055 |
| | 6 common x 0 Vdc 6 common x 24 Vdc with 1 fuse | TM5SPDG6D6F | 0.025/0.055 |

Dummy electronic module

| Characteristics | Used for | Reference | Weight kg/lb |
|-----------------|--|-----------|--------------|
| Non-functioning | Reservation of slots and logical address | TM5SD000 | 0.015/0.033 |

Bus bases

| Power supply | Characteristics | Sold in lots of | Unit reference | Weight kg/lb |
|------------------------------|-----------------|-----------------|----------------|--------------|
| 24 V $\overline{\text{---}}$ | - | 1 | TM5ACBM11 | 0.020/0.044 |
| | | 10 | TM5ACBM1110 | 0.200/0.440 |
| | Address setting | 1 | TM5ACBM15 | 0.020/0.044 |
| | | 10 | TM5ACBM1510 | 0.200/0.440 |

Terminal blocks

| Use | Description | Sold in lots of | Unit reference | Weight kg/lb |
|--|-------------|-----------------|----------------|--------------|
| For common distribution electronic module, 24 V $\overline{\text{---}}$ power supply | 6 contacts | 1 | TM5ACTB06 | 0.016/0.035 |
| | | 10 | TM5ACTB0610 | 0.160/0.350 |
| | 12 contacts | 1 | TM5ACTB12 | 0.020/0.044 |
| | | 10 | TM5ACTB1210 | 0.200/0.440 |

Accessories

See page 3/62

(1) Equipped with 5 x 20 internal fuse, slow-blow 6.3 A



Expansion modules

Modicon TM5 Analog modules
and Modicon TM5 Digital/Analog module
for Modicon M258 logic controller and Modicon LMC058
motion controller

| | |
|---------------------|--------------------------|
| Applications | Type of expansion module |
| Compatibility | |

| | | |
|--|---|--------------------------------------|
| 1 to 6 analog input channels | 1 analog input channel and 4 digital input channels 1 analog input channel and 2 digital output channels | 2 to 4 analog output channels |
| Modicon M258 logic controller, Modicon LMC058 motion controller | | |



With removable spring terminal blocks (to be ordered separately)

| | | | | | |
|--|------------------------------|--|------------------------------|--------------------------------|----------|
| 2 | 2 | 4 | 4 | 2 | 4 |
| Voltage/current | | | | Pt100/Pt1000 temperature probe | |
| - 10...+ 10 Vdc 0...20 mA/ 4...20 mA | - 10...+ 10 Vdc 0...20 mA | - 10...+ 10 Vdc 0...20 mA/ 4...20 mA | - 10...+ 10 Vdc 0...20 mA | - 200...+ 850°C | |
| 12 bits + sign | 15 bits + sign | 12 bits + sign | 15 bits + sign | 16 bits | |
| 300 µs | – | 400 µs | – | – | |
| 1 ms | 50 µs | 1 ms | 50 µs | – | |



With removable spring terminal blocks (to be ordered separately)

| | | | |
|---|----------|---------------------------|--|
| 2 | 6 | 1 | 1 |
| J, K, S, N thermocouple | | Full bridge Strain Gauge | Voltage/current |
| Type J: - 210...+ 1200°C Type K: - 270...+ 1372°C Type S: - 50...+ 1768°C Type N: - 270...+ 1300°C | | Differential: 85...5000 Ω | - 10...+ 10 Vdc 0...20 mA/4...20 mA |
| 16 bits | | 24 bits | 12 bits + sign |
| – | | – | 400 ms |
| – | | – | 1 ms max. |

Channel connection

| | |
|----------------------|-------------------------------------|
| Analog inputs | Number |
| | Type |
| Range | |
| Resolution | |
| Sampling period | without filtering with filtering |

| | |
|-----------------------|------------|
| Analog outputs | Number |
| | Type |
| | Range |
| | Resolution |
| Response time | |

| | |
|-----------------------|---------------------------|
| Digital inputs | Number |
| | Nominal input voltage |
| | IEC/EN 61131-2 conformity |
| | Type of signal (1) |
| | Type of wiring |
| | Limit values |
| | Nominal input current |
| | Input impedance |
| | State 0 |
| | State 1 |

| | |
|------------------------|---------------------------------------|
| Digital outputs | Number |
| | Nominal output voltage |
| | Output current per channel |
| | Output current per group of channels |
| | Type of signal (1) |
| | Type of wiring |
| | Limit values |
| | Short-circuit and overload protection |

Power supply

| | |
|------------------|------------------------|
| Isolation | Channel-to-channel |
| | Between channel groups |
| | Channel-to-bus |

Type of electronic module

Associated bus base (2)

Associated terminal block (2)

Page

| |
|--------------|
| Internal |
| Non-isolated |
| – |
| ~ 500 V RMS |

| | | | | | |
|----------|----------|----------|----------|-----------|-----------|
| TM5SAI2L | TM5SAI2H | TM5SAI4L | TM5SAI4H | TM5SAI2PH | TM5SAI4PH |
|----------|----------|----------|----------|-----------|-----------|

| |
|----------------------|
| TM5ACBM11, TM5ACBM15 |
|----------------------|

| | | | |
|----------------------|-----------|----------------------|-----------|
| TM5ACTB06, TM5ACTB12 | TM5ACTB12 | TM5ACTB06, TM5ACTB12 | TM5ACTB12 |
|----------------------|-----------|----------------------|-----------|

3/53

| | | | | |
|------------------------------|----------|------------------------------|----------------|----------------|
| 1 | 2 | 2 | 4 | 4 |
| Voltage/current | | Voltage/current | | |
| - 10...+ 10 Vdc 0...20 mA | | - 10...+ 10 Vdc 0...20 mA | | |
| 12 bits | | 12 bits + sign | 15 bits + sign | 12 bits + sign |
| 1 ms maxi | | 1 ms max. | | |

| |
|------------------|
| 4 |
| 24 V ∓ |
| Type 1 |
| Sink |
| 1-wire |
| ∓ 20.4... 28.8 V |
| 3.3 mA |
| 7.2 kΩ |
| ∓ 5 V max. |
| ∓ 15 V min. |

| |
|-----------------|
| 2 |
| 24 V ∓ |
| 0.5 A |
| 1 A max. |
| Source |
| 1-wire |
| ∓ 20.4...28.8 V |
| Yes |

| | | | |
|--------------|--------------|--------------|--------------|
| Internal | Internal | Internal | Internal |
| Non-isolated | Non-isolated | Non-isolated | Non-isolated |
| – | – | – | – |
| ~ 500 V RMS | ~ 500 V RMS | ~ 500 V RMS | ~ 500 V RMS |

| | | | | | | | |
|-----------|-----------|-----------|------------|----------|----------|----------|----------|
| TM5SAI2TH | TM5SAI6TH | TM5SEAI5G | TM5SMM6D2L | TM5SAO2L | TM5SAO2H | TM5SAO4L | TM5SAO4H |
|-----------|-----------|-----------|------------|----------|----------|----------|----------|

| |
|----------------------|
| TM5ACBM11, TM5ACBM15 |
|----------------------|

| | | | |
|----------------------|-----------|----------------------|-----------|
| TM5ACTB06, TM5ACTB12 | TM5ACTB12 | TM5ACTB06, TM5ACTB12 | TM5ACTB12 |
|----------------------|-----------|----------------------|-----------|

3/53

(1) Source output: PNP output, sink output: NPN output.
(2) to be ordered separately.

Presentation

TM5SAI●●● and **TM5SEIAISG** analog modules are used to acquire various analog values encountered in industrial applications.

TM5SAO●●● Analog output modules are used to control preactuators in physical units, such as variable speed drives or valves and applications where process control is required. The output current or voltage is proportional to the numerical value defined by the user program.

On a controller "stop", the outputs can be configured with fallback (set to the bottom scale value or held at their value). This function, with holding the value, is used when debugging the application or on a fault so as not to disturb the controlled process.

Each analog module consists of three parts to be ordered separately (1):

- An I/O electronic module
- A bus base
- A terminal block

These modules can be mechanically assembled before mounting on a symmetrical rail.

These modules offer the following advantages:

- Removable terminal
- Spring terminals which can be used for quick, tool-free connection of the sensors and preactuators in addition, the quality of the spring terminals avoids the need for periodic retightening
- Hot swapping

The offer of 13 analog modules:

- Four electronic modules with 2 or 4 voltage/current inputs
- Two electronic modules with 2 or 4 Pt100/Pt1000 temperature probes
- Two electronic modules with 2 or 6 J, K, S and N thermocouple inputs
- One electronic module with 1 Full-bridge strain gauge input
- Four electronic modules with 2 or 4 voltage/current outputs

Depending on the application requirements, these electronic modules are available in 12, 16 or 24 bit-resolution.

It is advisable to use the **TM2XMTGB** earthing plate which simplifies connection of the analog sensor and actuator cable shielding. This shielding must be connected to the device's functional earth.

Description

Analog modules comprise:

- 1 A bus base
- 2 A mechanical locking lever for mounting/dismounting on a symmetrical rail
- 3 On each side of the base, a bus expansion connection for the link with the previous controller or module
- 4 An analog input or output electronic module
- 5 A channel and module diagnostics LED display block
- 6 A slot for labelling (label-holder)
- 7 A removable spring terminal block with locking lever and slots for coloured identifiers

(1) Also sold in kits, see page 3/63

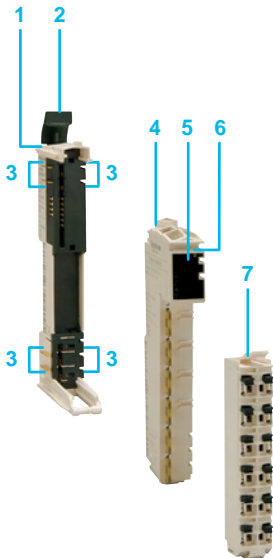

Expansion modules

Modicon TM5 Analog modules

for Modicon M258 logic controller and Modicon LMC058 motion controller



TM5SAI●●



TM5SAO●●



TM5ACBM●●



TM5ACTB●●



TM2XMTGB



TM200RSRCMC

References

Analog input electronic modules

| Number and type of inputs | Input range | Resolution | Reference | Weight kg/ lb |
|---|---------------------------------------|----------------|-----------|---------------------|
| 2 voltage/current inputs | - 10...+ 10 V DC, 0...20 mA/4...20 mA | 12 bits + sign | TM5SAI2L | 0.025/ 0.055 |
| | - 10...+ 10 V DC, 0...20 mA | 15 bits + sign | TM5SAI2H | |
| 4 voltage/current inputs | - 10...+ 10 Vdc, 0...20 mA/ 4...20 mA | 12 bits + sign | TM5SAI4L | |
| | - 10...+ 10 V DC, 0...20 mA | 15 bits + sign | TM5SAI4H | |
| 2 Pt100/Pt1000 temperature probe inputs | - 200...+ 850°C | 16 bits | TM5SAI2PH | |
| 4 Pt100/Pt1000 temperature probe inputs | | 16 bits | TM5SAI4PH | |
| 2 J, K, S, N thermocouple inputs | Type J: - 210...+ 1200°C | 16 bits | TM5SAI2TH | |
| 6 J, K, S, N thermocouple inputs | Type K: - 270...+ 1372°C | 16 bits | TM5SAI6TH | |
| | Type S: - 50...+ 1768°C | | | |
| | Type N: - 270...+ 1300°C | | | |
| 1 Full bridge strain gauge input | Differential: 85...5000 Ω | 24 bits | TM5SEAISG | |

Analog output electronic modules

| Nber and type of O | Output range | Resolution | Reference | Weight kg/ lb |
|---------------------------|-----------------------------|----------------|-----------|---------------------|
| 2 voltage/current outputs | - 10...+ 10 V DC, 0...20 mA | 12 bits + sign | TM5SAO2L | 0.025/ 0.055 |
| | | 15 bits + sign | TM5SAO2H | |
| 4 voltage/current outputs | - 10...+ 10 V DC, 0...20 mA | 12 bits + sign | TM5SAO4L | |
| | | 15 bits + sign | TM5SAO4H | |

Bus bases

| Power supply | Characteristics | Sold in lots of | Unit reference | Weight kg/ lb |
|--------------|-----------------|-----------------|----------------|---------------------|
| 24 V ~ | - | 1 | TM5ACBM11 | 0.020/ 0.044 |
| | | 10 | TM5ACBM1110 | 0.200/ 0.440 |
| | Address setting | 1 | TM5ACBM15 | 0.020/ 0.044 |
| | | 10 | TM5ACBM1510 | 0.200/ 0.440 |

Terminal blocks

| Use | Type | Sold in lots of | Unit reference | Weight kg/ lb |
|--|-------------|-----------------|----------------|---------------------|
| For analog I/O electronic module, 24 V ~ power supply | 6 contacts | 1 | TM5ACTB06 | 0.016/ 0.035 |
| | | 10 | TM5ACTB0610 | 0.160/ 0.350 |
| | 12 contacts | 1 | TM5ACTB12 | 0.020/ 0.044 |
| | | 10 | TM5ACTB1210 | 0.200/ 0.440 |

Accessories

See page 3/62

Separate parts

| Designation | Description | Unit reference | Weight kg/ lb |
|---|--|----------------|---------------------|
| Earthing plate | Support equipped with 10 male Faston connectors for connecting the cable shielding (via 6.35 mm connectors, not supplied) and the functional earths (FE) | TM2XMTGB | 0.045/ 0.099 |
| Shielding connection clamps Sold in lots of 25 | Attachment and earthing of the cable shielding. Pack of 25 clamps including 20 for Ø 4.8 mm cable and 5 for Ø 7.9 mm cable | TM200RSRCMC | - |
| Mounting kit (Sold in lots of 5) | For mounting the analog modules on a plate or panel | TWDXMT5 | 0.065/ 0.143 |

Analog I/O expansion module kits

See page 3/63

Expansion modules

Modicon TM5 Expert modules
for Modicon M258 logic controller
and Modicon LMC058 motion controller

| | |
|---------------|---|
| Applications | Upcounting, downcounting, period measurement, frequency meter, frequency generator, axis following with encoder |
| Compatibility | Modicon M258 logic controller, Modicon LMC058 motion controller |



| | | |
|-------------------------------|--|--|
| Channel connection | With removable spring terminal blocks (to be ordered separately) | |
| Number of counter channels | 2 | 1 |
| IEC/EN 61131-2 conformity | Type 1 | Incremental |
| Type of signal (1) | Sink | Sink |
| Type of input | 1-, 2- or 3-wire | – |
| Nominal input voltage | 24 V $\overline{\text{---}}$ | 24 V $\overline{\text{---}}$ asymmetrical |
| Voltage limit values | 20.4... 28.8 V $\overline{\text{---}}$ | – |
| Frequency per channel | 50 kHz | 100 kHz |
| Resolution | – | 16/32 bits |
| Functions | Event counting Interval measurement | 2 x 24 V $\overline{\text{---}}$ auxiliary inputs 24 V $\overline{\text{---}}$ encoder power supply |
| Types of counter module | TM5SDI2DF | TM5SE1IC01024 |
| Compatible bus base (2) | TM5ACBM11, TM5ACBM15 | |
| Compatible terminal block (2) | TM5ACTB12 | |
| Page | 3/57 | |

(1) Source output: PNP output, sink output: NPN output.
(2) To be ordered separately.

| | | | |
|---------------|---|--|--|
| Applications | Upcounting, downcounting, period measurement, frequency meter, frequency generator, axis following with encoder | | |
| Compatibility | Modicon M258 logic controller, Modicon LMC058 motion controller | | |



| | | | |
|-------------------------------|--|---|---|
| Channel connection | With removable spring terminal blocks (to be ordered separately) | | |
| Number of counter channels | 2 | 1 | 1 |
| IEC/EN 61131-2 conformity | Incremental | Incremental | SSI absolute |
| Type of signal (1) | Sink | RS422, Sink | Sink |
| Type of input | – | – | – |
| Nominal input voltage | 24 V $\overline{\text{---}}$ asymmetrical | 5 V $\overline{\text{---}}$ symmetrical | 5 V $\overline{\text{---}}$ symmetrical |
| Voltage limit values | – | 20.4... 28.8 V $\overline{\text{---}}$ | 20.4... 28.8 V $\overline{\text{---}}$ |
| Frequency per channel | 100 kHz | 250 kHz | 1 MHz |
| Resolution | 16/32 bits | 16/32 bits | 32 bits |
| Functions | 2 x 24 V $\overline{\text{---}}$ auxiliary inputs 24 V $\overline{\text{---}}$ encoder power supply | 2 x 24 V $\overline{\text{---}}$ auxiliary inputs | 2 x 24 V $\overline{\text{---}}$ auxiliary inputs |
| Types of counter module | TM5SE2IC01024 | TM5SE1IC02505 | TM5SE1SC10005 |
| Compatible bus base (2) | TM5ACBM11, TM5ACBM15 | | |
| Compatible terminal block (2) | TM5ACTB12 | | |
| Page | 3/57 | | |

(1) Source output: PNP output, sink output: NPN output.
(2) To be ordered separately.

Expansion modules

Modicon TM5 Expert modules for Modicon M258 logic controller and Modicon LMC058 motion controller

3

Presentation

TM5SDI12DF and **TM5SE●●●●●●●●** Expert modules for Modicon M258 logic controller and LMC058 motion controllers are used to count the pulses generated by a sensor or to process the signals from an incremental encoder, depending on the reference chosen.

The extent of the high-speed counter module offer makes it possible to adapt the configuration to the machine's precise requirements: the five counter modules differ in their frequency and their functions.

| Expert electronic modules | No. of channels | Max. frequency | Integrated functions | Signal |
|---------------------------|-----------------|----------------|---|--------|
| TM5SDI12DF | 2 | 50 kHz | Event counting, interval measurement | Sink |
| TM5SE1IC01024 | 1 | 100 kHz | 2 x 24 V $\overline{\text{---}}$ auxiliary inputs 24 V $\overline{\text{---}}$ encoder power supply | Sink |
| TM5SE2IC01024 | 2 | 100 kHz | 2 x 24 V $\overline{\text{---}}$ auxiliary inputs 24 V $\overline{\text{---}}$ encoder power supply | Sink |
| TM5SE1IC02505 | 1 | 250 kHz | 2 x 24 V $\overline{\text{---}}$ auxiliary inputs $\overline{\text{---}}$ 5 V encoder power supply | Sink |
| TM5SE1SC10005 | 1 | 1 MHz | 2 x 24 V $\overline{\text{---}}$ auxiliary inputs $\overline{\text{---}}$ 5 V SSI encoder power supply | Sink |

The function parameters are set by configuration using SoMachine software.

Each Expert module consists of three parts to be ordered separately:

- An electronic counter module
- A bus base
- A terminal block

These modules can be mechanically assembled before mounting on a symmetrical rail.

These modules offer the following advantages:

- Removable terminal
- Spring terminals which can be used for quick, tool-free connection of the sensors and preactuators in addition, the quality of the spring terminals avoids the need for periodic retightening
- Hot swapping

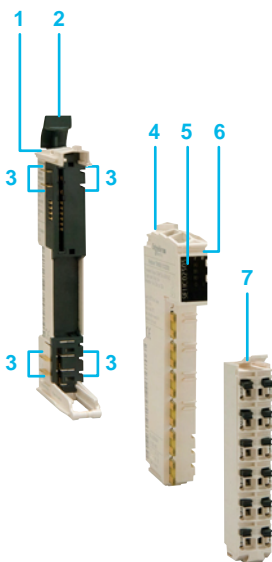

Description

TM5 Expert modules comprise:

- 1 A bus base
- 2 A mechanical locking lever for mounting/dismounting on a symmetrical rail
- 3 On each side of the base, a bus expansion connection for the link with the previous controller or module
- 4 An electronic counter module
- 5 A channel and module diagnostics LED display block
- 6 A slot for labelling (label-holder)
- 7 A removable spring terminal block with locking lever and slots for coloured identifiers

Expansion modules

Modicon TM5 Expert modules
for Modicon M258 logic controller and Modicon LMC058
motion controller



TM5SDI2DF



TM5SE●●●●●●●●



TM5ACBM●●



TM5ACTB●●

References

Expert electronic modules

| Counting frequency | Number of channels | Function | Reference | Weight kg/lb |
|--------------------|--------------------|--|---------------|-----------------|
| 50 kHz | 2 | Event counting, interval measurement | TM5SDI2DF | 0.025/ 0.055 |
| 100 kHz | 1 | 2 x 24 V $\overline{\text{---}}$ auxiliary inputs 24 V $\overline{\text{---}}$ encoder power supply | TM5SE1IC01024 | 0.025/ 0.055 |
| | 2 | 2 x 24 V $\overline{\text{---}}$ auxiliary inputs 24 V $\overline{\text{---}}$ encoder power supply | TM5SE2IC01024 | 0.025/ 0.055 |
| 250 kHz | 1 | 2 x 24 V $\overline{\text{---}}$ auxiliary inputs | TM5SE1IC02505 | 0.025/ 0.055 |
| 1 MHz | 1 | 2 x 24 V $\overline{\text{---}}$ auxiliary inputs | TM5SE1SC10005 | 0.025/ 0.055 |

Bus bases

| Power supply | Characteristics | Sold in lots of | Unit reference | Weight kg/lb |
|------------------------------|-----------------|-----------------|----------------|-----------------|
| 24 V $\overline{\text{---}}$ | – | 1 | TM5ACBM11 | 0.020/ 0.044 |
| | | 10 | TM5ACBM1110 | 0.200/ 0.440 |
| | Address setting | 1 | TM5ACBM15 | 0.020/ 0.044 |
| | | 10 | TM5ACBM1510 | 0.200/ 0.440 |

Terminal blocks

| Use | Description | Sold in lots of | Unit reference | Weight kg/lb |
|---|-------------|-----------------|----------------|-----------------|
| For electronic counter module powered with 24 V $\overline{\text{---}}$ | 12 contacts | 1 | TM5ACTB12 | 0.020/ 0.044 |
| | | 10 | TM5ACTB1210 | 0.200/ 0.440 |

Accessories

See page 3/62

Expansion modules

Modicon TM5 power distribution modules
for Modicon M258 logic controller and Modicon LMC058
motion controller

Presentation

TM5SP●● power distribution modules are intended to supply power to the I/O modules and/or the TM5 bus.

Each power distribution module consists of three parts to be ordered separately:

- A power distribution electronic module
- A bus base
- A terminal block

These modules can be mechanically assembled before mounting on a symmetrical rail.

These modules offer the following advantages:

- Removable terminal
- Spring terminals which can be used for quick, tool-free connection of the sensors and preactuators in addition, the quality of the spring terminals avoids the need for periodic retightening.

Four power distribution modules are available.

3

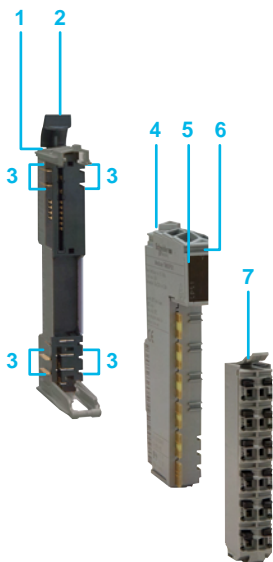

Description

Power distribution modules comprise:

- 1 A bus base
- 2 A mechanical locking lever for mounting/dismounting on a symmetrical rail
- 3 On each side of the base, a bus expansion connection for the link with the previous controller or module
- 4 A power distribution electronic module
- 5 A channel and module diagnostics LED display block
- 6 A slot for labelling (label-holder)
- 7 A removable spring terminal block with locking lever and slots for coloured identifiers

Expansion modules

Modicon TM5 power distribution modules for Modicon M258 logic controller and Modicon LMC058 motion controller



TM5SP●●



TM5ACBM●●



TM5ACTB●●

References

Power distribution electronic modules

| Input power supply | Used for | Fuse | Reference | Weight kg/lb |
|--------------------|--|---------------------|-----------------|-----------------|
| 24 V ⎓ | Supplying power to the I/O modules in 24 V ⎓ Total I max: 10 A | – | TM5SPS1 | 0.030/ 0.066 |
| | | 6.3 A internal fuse | TM5SPS1F | 0.030/ 0.066 |
| 24 V ⎓ | Supplying power □ to the I/O modules in 24 V ⎓ □ and the TM5 bus (Bus power supply: 7 W) | – | TM5SPS2 | 0.030/ 0.066 |
| | | 6.3 A internal fuse | TM5SPS2F | 0.030/ 0.066 |

Bus bases

| Power supply | Characteristics | Sold in lots of | Unit reference | Weight kg/lb |
|--------------|--|-----------------|---------------------|-----------------|
| 24 V ⎓ | Isolated on the left on the power supply to the I/O modules in 24 V ⎓ | 1 | TM5ACBM01R | 0.020/ 0.044 |
| | | 10 | TM5ACBM01R10 | 0.200/ 0.440 |
| 24 V ⎓ | Isolated on the left on the power supply to the I/O modules in 24 V ⎓ Address setting | 1 | TM5ACBM05R | 0.020/ 0.044 |
| | | 10 | TM5ACBM05R10 | 0.200/ 0.440 |

Terminal block

| Use | Characteristics | Reference | Weight kg/lb |
|---|-----------------|--------------------|-----------------|
| For power distribution electronic module 24 V ⎓ | 12 contacts | TM5ACTB12PS | 0.020/ 0.044 |

Accessories

See page 3/62



Expansion modules

Modicon TM5 Transmitter and Receiver modules

for Modicon M258 logic controller and Modicon LMC058 motion controller

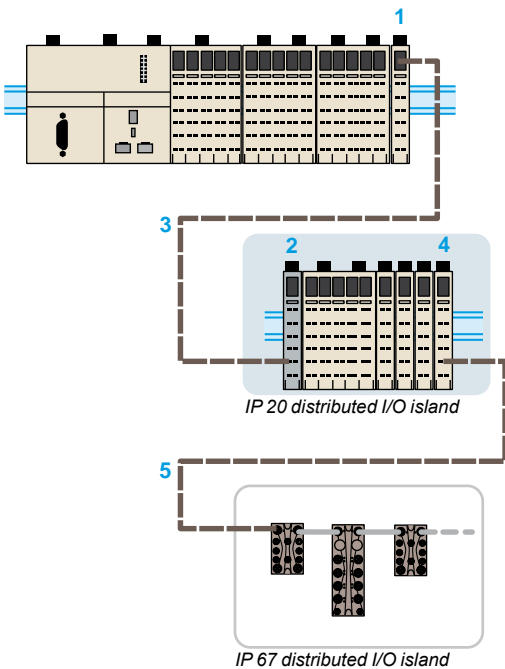

3

Presentation

M258 logic controllers and LMC058 motion controllers offer the possibility of creating IP 20 islands of distributed I/O via the TM5 expansion bus.

This makes it possible to:

- Adapt the architecture as closely as possible to the machine topology
- Reduce the wiring costs by minimizing the distance between the modules and the sensors/preactuators
- Take full advantage of the TM5 expansion bus exchange performance
- Save the cost of a fieldbus connection

In addition, irrespective of the expansion module local or remote slot, the modules remain synchronized due to use of the same expansion bus. Modicon TM5 Remote modules are needed to:

- Increase the number of remote I/O on a M258 logic controller and an LMC058 motion controller beyond 100 m
- Exchange incoming and outgoing data produced by the I/O expansion modules
- Guarantee the performance of data exchanges

Three remote modules are available:

- The **TM5SBET1** electronic module: transmitter (1), for data transmission between IP 20 islands
- The **TM5SBET7** electronic module: transmitter (4), for data transmission from an IP 20 island to an IP 67 island (1) via a TM7 expansion bus (5)
- **TM5SBER2** electronic modules: receiver (2)

The transmitter (1) and receiver (2) modules are physically linked by the remote connection cable (3) **TCSXCNNXN100**.

The maximum distance between islands is 100 m and it is possible to connect up to 25 remote islands.

Each remote module consists of three parts to be ordered separately:

- An electronic module, either transmitter or receiver
- A bus base
- A connection block

These modules can be mechanically assembled before mounting on a symmetrical rail.

These modules offer the following advantages:

- Removable connector
- Spring terminals which can be used for quick, tool-free connection of the sensors and preactuators. In addition, the quality of the spring terminals avoids the need for periodic retightening

Description

Transmitter and receiver modules comprise:

- 1 A bus base
- 2 A mechanical locking lever for mounting/dismounting on a symmetrical rail
- 3 On each side of the base, a bus expansion connection for the link with the previous controller or module
- 4 A remote I/O electronic module, either transmitter or receiver
- 5 A channel and module diagnostics LED display block
- 6 A slot for labelling (label-holder)
- 7 A removable spring terminal block with locking lever and slots for coloured identifiers

(1) IP 67 islands. Composition: TM7 blocks and TM7 expansion bus. See page 3/64.

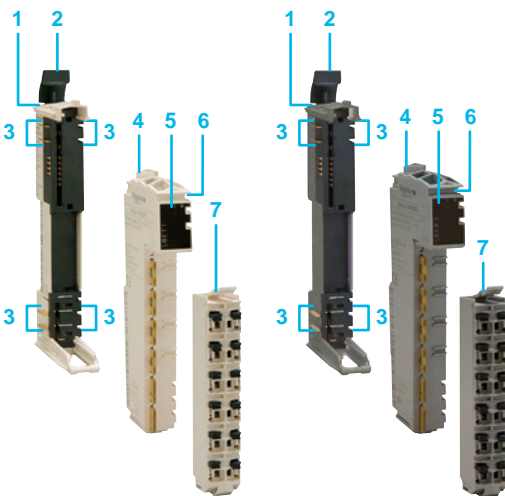

Transmitter module

Receiver module

Expansion modules

Modicon TM5 Transmitter and Receiver modules

for Modicon M258 logic controller and Modicon LMC058 motion controller



TM5SBET1 TM5SBET7



TM5SBER2



TM5ACBM1●



TM5ACBM0●R



TM5ACTB●●



TM5ACTB12PS

References

Remote I/O electronic modules

| Description | Characteristics | Reference | Weight kg/ lb |
|--------------------|--|-----------|---------------------|
| Transmitter module | Electronic module for data transmission between IP 20 I/O islands (1) | TM5SBET1 | 0.025/ 0.055 |
| | Electronic module for data transmission between IP 20 I/O island and IP 67 I/O island (2) Includes the power supply for the TM7 expansion modules (2) | TM5SBET7 | |
| Receiver module | Data reception electronic module Power distribution module for electronic modules and the TM5 bus, 24 V $\bar{\text{v}}$ power supply | TM5SBER2 | |

Expansion bus

| Description | Usage | Length m/ft | Reference | Weight kg/ lb |
|-------------------------|---|----------------|--------------|---------------------|
| Remote connection cable | Bus extension by linking transmitter and receiver modules | 100/ 328.08 | TCSXCNNXN100 | 8.800/ 19.401 |

Bus bases

| Power supply | For use with | Sold in lots of | Unit reference | Weight kg/ lb |
|-----------------------|--|-----------------|----------------|---------------------|
| - | TM5SBET1 and TM5SBET7 transmitter modules | 1 | TM5ACBM11 | 0.020/ 0.044 |
| | | 10 | TM5ACBM1110 | 0.200/ 0.440 |
| | TM5SBET1 and TM5SBET7 transmitter modules with address setting | 1 | TM5ACBM15 | 0.020/ 0.044 |
| | | 10 | TM5ACBM1510 | 0.200/ 0.440 |
| 24 V $\bar{\text{v}}$ | TM5SBER2 receiver module | 1 | TM5ACBM01R | 0.020/ 0.044 |
| | | 10 | TM5ACBM01R10 | 0.200/ 0.440 |
| | TM5SBER2 receiver module, with address setting | 1 | TM5ACBM05R | 0.020/ 0.044 |
| | | 10 | TM5ACBM05R10 | 0.200/ 0.440 |

Terminal blocks

| For use with | Characteristics | Sold in lots of | Unit reference | Weight kg/ lb |
|--|-----------------|-----------------|----------------|---------------------|
| Transmitter module TM5SBET1 | 6 contacts | 1 | TM5ACTB06 | 0.016/ 0.035 |
| | | 10 | TM5ACTB0610 | 0.160/ 0.350 |
| Transmitter modules TM5SBET1 and TM5SBET7 | 12 contacts | 1 | TM5ACTB12 | 0.020/ 0.044 |
| | | 10 | TM5ACTB1210 | 0.200/ 0.440 |
| Receiver module TM5SBER2 | 12 contacts | 1 | TM5ACTB12PS | 0.020/ 0.044 |

Accessories

See page 3/62

(1) IP 20 I/O islands, see page 4/24.

(2) IP 67 I/O islands, see page 4/28.



TM5ACTCH100



TM5ACTLC100



TM5ACLPL10



TM5ACLPR10

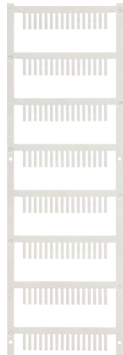

TM5ACLITW1

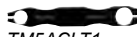

TM5ACLT1



TM5ACADL100

References

Accessories

| Description | Used for | Colour | Sold in lots of | Unit reference | Weight kg/lb |
|--|---|-------------|-----------------|----------------|--------------|
| Plain text cover holder (label-holder) | Marking the terminal blocks on the I/O channels | Transparent | 100 | TM5ACTCH100 | 0.002/0.004 |
| Plain text cover holder locking clip <i>(Order with plain text cover holder TM5ACTCH100)</i> | Locking plain text cover holder TM5ACTCH100 | Transparent | 100 | TM5ACTLC100 | 0.001/0.002 |
| Precut legend strips of paper | Plain text cover holder TM5ACTCH100 | White | 100 | TM5ACTLS100 | 0.001/0.002 |
| Coloured plastic identifiers | Labelling 16 connection channel terminals | White | 1 | TM5ACLITW1 | 0.015/0.033 |
| | | Red | 1 | TM5ACLITR1 | 0.015/0.033 |
| | | Blue | 1 | TM5ACLITB1 | 0.015/0.033 |
| Metal tool | Inserting/removing TM5ACLT1 identifiers | Black | 1 | TM5ACLT1 | 0.030/0.066 |
| Retaining plates for bus bases | Held on the left side | White | 10 | TM5ACLPL10 | 0.004/0.009 |
| | Held on the right side | White | 10 | TM5ACLPR10 | 0.004/0.009 |
| Locking clips | For modules | Black | 100 | TM5ACADL100 | 0.001/0.002 |



TM5SD12DK



TM5SDO4RK

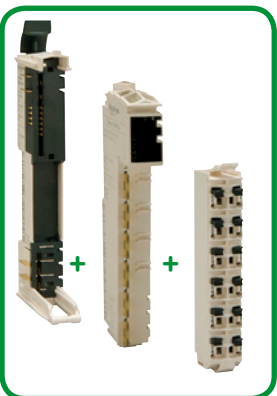

TM5SA4K

References

Digital I/O expansion module kits

24 V $\overline{\text{DC}}$ power supply

| Designation | Composition | Reference | Weight kg/ lb |
|---|---|-------------------|---------------------|
| Kit including: a digital input or output electronic module, a bus base, a terminal block | TM5SDI12D + TM5ACBM11 + TM5ACTB12 | TM5SDI12DK | 0.065/ 0.143 |
| | TM5SDO12T + TM5ACBM11 + TM5ACTB12 | TM5SDO12TK | |

Digital I/O expansion module kit

100/240 V \sim power supply

| Designation | Composition | Reference | Weight kg/ lb |
|--|--|------------------|---------------------|
| Kit including: a digital output electronic module, a bus base, a terminal block | TM5SDO4R + TM5ACBM12 + TM5ACTB32 | TM5SDO4RK | 0.070/ 0.154 |

Analog I/O expansion module kits

| Designation | Composition | Reference | Weight kg/ lb |
|--|--|------------------|---------------------|
| Kits including: an analog input or output electronic module, a bus base, a terminal block | TM5SAI4L + TM5ACBM11 + TM5ACTB12 | TM5SAI4LK | 0.075/ 0.165 |
| | TM5SAI4H + TM5ACBM11 + TM5ACTB12 | TM5SAI4HK | |
| | TM5SAO4L + TM5ACBM11 + TM5ACTB12 | TM5SAO4LK | |

Expansion modules

Modicon TM7 blocks

for Modicon M258 logic controller and Modicon LMC058 motion controller

Presentation

To enhance its "Flexible machine Control" concept, Schneider Electric offers Modicon TM7 IP 67 blocks for mounting outside electrical cabinets, directly on the installation.

The IP 67 protection of these blocks enables them to be used within processes or machines in harsh environments (splashing water, oil, dust, etc.).

They have the following characteristics:

- Dust and damp proof
- Robust and compact
- Rapid wiring, economical to use

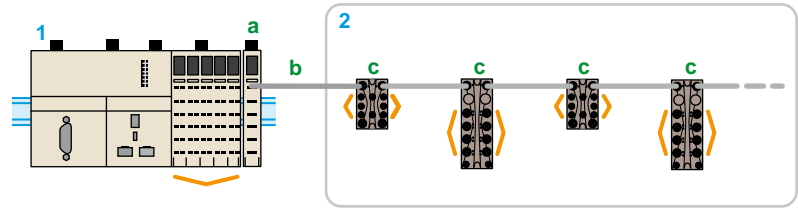

IP 67 distributed I/O island

Inputs/outputs

- 1 Modicon M258 logic controller, Modicon LMC058 motion controller: CANopen bus masters + transmitter module TM5SBET7 (a) (1).
- 2 IP 67 distributed I/O islands. Composition: TM7 expansion bus cable (b) + TM7 digital/analog I/O expansion blocks (c).

Modicon TM7 block offer

Modicon TM7 IP 67 blocks are available in various compositions and for different functions.

Digital blocks

The offer comprises:

- Three input blocks
- Three configurable I/O blocks
- One output block

Analog blocks

The offer comprises:

- Two expansion blocks with 4 inputs for connecting 4 sensors
- Two expansion blocks with 4 outputs for connecting 4 actuators
- Two mixed expansion blocks with 2 inputs and 2 outputs
- Two expansion blocks with 4 resistive temperature probe or thermocouple temperature measurement channels

Power distribution block

A power distribution block is available as an option to supply I/O expansion blocks on the TM7 expansion bus.

This power distribution block is necessary to avoid voltage drops in the following situations:

- With a TM7 NCOM08B CANopen interface block followed by 4 (2) TM7 I/O expansion blocks
- With a TM5SBET7 transmitter module (1) followed by 6 (2) TM7 I/O expansion blocks (mounted vertically)
- With a TM7 NCOM16A/16B CANopen interface block followed by 18 (2) TM7 I/O expansion blocks

Note: These limits must be weighted according to the cable lengths.

Consult the SPIG (System Planning and Installation Guide) for the Modicon TM7 IP 67 block offer on www.schneider-electric.com

Connection accessories

A range of cables and connectors is available for connecting the:

- CAN bus
- TM7 expansion bus
- I/O
- 24 V $\bar{\bar{}}$ power supplies on TM7 expansion blocks

CANopen interface blocks with digital I/O (see page 4/32)

The interface I/O block offer comprises IP 67 blocks that connect to a CANopen bus and have digital channels that can be configured as inputs or outputs, including:

- A CANopen interface block with 8 configurable I/O for connection via M8 connector
- Two CANopen interface blocks with 16 configurable I/O

(1) TM5 transmitter (see page 3/61).

(2) Minimum number.



Digital I/O expansion block



Analog I/O expansion block



Power distribution block

Expansion modules

Modicon TM7 blocks

for Modicon M258 logic controller and Modicon LMC058 motion controller

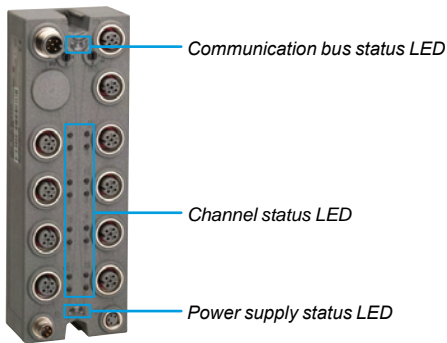

Diagnostics functions

The diagnostic monitoring of faults is indicated by LEDs on CANopen interface I/O blocks, expansion blocks and power distribution blocks and informs the control system (M258 logic controller, or M340 or Premium automation platforms) via the TM7 bus.

Each Modicon TM7 block has LEDs

- To display the status of the TM7 bus, the channel and the power supply
- For quick, precise location of a fault

There are several levels of diagnostics:

- Diagnostics per channel:
 - State of inputs
 - State of outputs
- Diagnostics per expansion block:
 - Sensor/actuator power supply present
 - Undervoltage fault on the I/O power supply
 - Analog input diagnostics
 - Short-circuit or overload on one or more digital outputs
- Communication bus diagnostics:
 - On CAN bus (CANopen interface I/O block)
 - On TM7 expansion bus (CANopen interface I/O block and I/O expansion blocks)
- Diagnostics of the power supply via the TM7 bus (expansion block only)

Specifications

| | | |
|---|---|---|
| Conformity with standards | IEC 61131-2 | |
| Product certifications | CE, cURus, GOST-R and c-Tick, ATEX (II 3g EEx nA II T5, IP 67, Ta = 0...60°C) | |
| Temperature | Operation | - 10...+ 60°C (14...140°F) |
| | Storage | - 25...+ 85°C (- 13...185°F) |
| Relative humidity | 5...95% (without condensation) | |
| Degree of pollution conforming to IEC 60664 | 2 | |
| Degree of protection conforming to IEC 61131-2 | IP 67 | |
| Altitude | Operation | 0...2000 m (0...6560 ft.) (1) |
| | Storage | 0...3000 m (0...9842 ft.) |
| Vibration resistance conforming to IEC 60721-3-5 Class 5M3 | DIN rail mounted | 7.5 mm (0.295 in.) 2...8 Hz fixed amplitude 20 m/s ² (2 gn) 8...200 Hz fixed acceleration 40 m/s ² (4 gn) 200...500 Hz fixed acceleration |
| | | |
| | | |
| Shock resistance conforming to IEC 60721-3-5 Class 5M3 | | 300 m/s ² (30 gn) for 11 ms, 1/2 sine wave, type 1 shock |
| Connectors | Type | M8 and/or M12 |
| | Number of operations | 50 min. |

Electromagnetic compatibility

| | |
|---|---|
| Electrostatic discharges conforming to IEC/EN 61000-4-2 | ± 8 kV, criterion B (air discharge) ± 4 kV, criterion B (direct discharge) |
| Electromagnetic fields conforming to IEC/EN 61000-4-3 | 10 V/m, amplitude modulation 80% at 1 kHz (80 MHz...2 GHz) 1 V/m (2...2.7 GHz) |
| Fast transients conforming to IEC/EN 61000-4-4 | Supply: 2 kV, criterion B I/O: 1 kV, criterion B Shielded cable: 1 kV, criterion B Repetition frequency: 5 and 100 kHz |
| Immunity to overvoltages, 24 V $\overline{\text{---}}$ circuit conforming to IEC/EN 61000-4-5 | Supply: □ 1 kV (12 Ω), criterion B in common mode □ 0.5 kV (2 Ω), criterion B in differential mode Unshielded links: □ 1 kV (42 Ω), criterion B in common mode □ 0.5 kV (42 Ω), criterion B in differential mode Shielded links: □ 1 kV (12 Ω), criterion B in common mode □ 0.5 kV (2 Ω), criterion B in differential mode |
| Induced magnetic fields conforming to IEC/EN 61000-4-6 | Line supply, I/O signal connections > 10 m (32.8 ft.) Functional earth connection: 10 Vrms, criterion A, amplitude modulation 80% at 1 kHz (150...80 MHz) |
| Conducted emissions conforming to EN 55011 (IEC/CISPR11) | 150...500 kHz, peak 79 dB μV 500 kHz...30 MHz, peak 73 dB μV |
| Radiated emissions conforming to EN 55011 (IEC/CISPR11) | 30...230 MHz, 10 m (32.8 ft) at 40 dB (μV/m) 230 MHz...1 GHz, 10 m (32.8 ft) at 47 dB (μV/m) |

(1) Temperature reduction of 0.5°C (32.9°F) for every additional 100 m (328 ft.) altitude above 2000 m (6560 ft.). Refer to the instruction sheet for each product, downloadable from www.schneider-electric.com

Expansion modules

Modicon TM7 blocks
Digital blocks for Modicon M258 logic controller and
Modicon LMC058 motion controller

Applications

Digital I/O expansion blocks



Degree of protection

| | | |
|-------|-------|-------|
| IP 67 | IP 67 | IP 67 |
|-------|-------|-------|

Type of housing

| | | |
|---------|---------|---------|
| Plastic | Plastic | Plastic |
|---------|---------|---------|

| | | | | |
|------------------------------------|---------------------------------|---|----|----|
| Modularity (number of channels) | Max. number of digital channels | 8 | 16 | 16 |
| | Digital inputs | 8 | 16 | 16 |
| | Digital outputs | – | – | – |

| | | |
|---------------------------|---------------------------|---------------------------|
| 24 V $\overline{=}$ /7 mA | 24 V $\overline{=}$ /7 mA | 24 V $\overline{=}$ /7 mA |
| Sink (1) | Sink (1) | Sink (1) |
| Type 1 | Type 1 | Type 1 |

| | | | | |
|----------------|------------------------|---------------------------|---------------------------|---------------------------|
| Digital inputs | Voltage/current | 24 V $\overline{=}$ /7 mA | 24 V $\overline{=}$ /7 mA | 24 V $\overline{=}$ /7 mA |
| | Type | Sink (1) | Sink (1) | Sink (1) |
| | IEC 61131-2 conformity | Type 1 | Type 1 | Type 1 |

| | | |
|---|---|---|
| – | – | – |
| – | – | – |
| – | – | – |

| | | | | |
|-----------------|-----------------------------|---|---|---|
| Digital outputs | Voltage | – | – | – |
| | Type | – | – | – |
| | Current per output | – | – | – |
| | Current per expansion block | – | – | – |

| | | |
|--|--|--|
| 24 V $\overline{=}$ | 24 V $\overline{=}$ | 24 V $\overline{=}$ |
| 500 mA for all channels | 500 mA for all channels | 500 mA for all channels |
| Overloads, short-circuits and reverse polarity | Overloads, short-circuits and reverse polarity | Overloads, short-circuits and reverse polarity |

| | | | | |
|------------------------------|--------------------|--|--|--|
| Sensor/actuator power supply | Voltage | 24 \rightarrow $\overline{=}$ | 24 V $\overline{=}$ | 24 V $\overline{=}$ |
| | Max. current | 500 mA for all channels | 500 mA for all channels | 500 mA for all channels |
| | Protection against | Overloads, short-circuits and reverse polarity | Overloads, short-circuits and reverse polarity | Overloads, short-circuits and reverse polarity |

| | | |
|--------------------------|--------------------------|--------------------------|
| B-coded 4-way male M12 | B-coded 4-way male M12 | B-coded 4-way male M12 |
| B-coded 4-way female M12 | B-coded 4-way female M12 | B-coded 4-way female M12 |

| | | | | | |
|----------------------|-------------------|------------------------------|--|--|--|
| Connection | TM7 expansion bus | Bus input connector | B-coded 4-way male M12 | B-coded 4-way male M12 | B-coded 4-way male M12 |
| | | Bus output connector | B-coded 4-way female M12 | B-coded 4-way female M12 | B-coded 4-way female M12 |
| Digital I/O channels | – | Sensor connector | 3-way female M8, 1 channel per connector | 3-way female M8, 1 channel per connector | A-coded 5-way female M12, 2 channels per connector |
| | | Actuator connector | – | – | – |
| | | Expansion block power supply | Input connector | 4-way male M8 | 4-way male M8 |
| – | – | Output connector | 4-way female M8 | 4-way female M8 | 4-way female M8 |

| | | |
|--|--|--|
| – | – | – |
| 3-way female M8, 1 channel per connector | 3-way female M8, 1 channel per connector | A-coded 5-way female M12, 2 channels per connector |
| – | – | – |
| 4-way male M8 | 4-way male M8 | 4-way male M8 |
| 4-way female M8 | 4-way female M8 | 4-way female M8 |

| | | | | |
|-------------|-----------------------------|-----|-----|-----|
| Diagnostics | By expansion block | Yes | Yes | Yes |
| | By channel | Yes | Yes | Yes |
| | By communication on TM7 bus | Yes | Yes | Yes |

| | | |
|-----|-----|-----|
| Yes | Yes | Yes |
| Yes | Yes | Yes |
| Yes | Yes | Yes |

Type of expansion block

| | | |
|-----------------|------------------|------------------|
| TM7BDI8B | TM7BDI16B | TM7BDI16A |
|-----------------|------------------|------------------|

Pages

| |
|------|
| 3/69 |
|------|

(1) Sink inputs: positive logic
(2) Source outputs: positive logic

| | | | |
|-------|-------|-------|-------|
| IP 67 | IP 67 | IP 67 | IP 67 |
|-------|-------|-------|-------|

| | | | |
|---------|---------|---------|---------|
| Plastic | Plastic | Plastic | Plastic |
|---------|---------|---------|---------|

| | | | |
|---|-----------------------------|------------------------------|------------------------------|
| 8 | 8 | 16 | 16 |
| – | 0...8 software-configurable | 0...16 software-configurable | 0...16 software-configurable |
| 8 | 0...8 software-configurable | 0...16 software-configurable | 0...16 software-configurable |

| | | | |
|---|-----------------------------|-----------------------------|---------------------------------|
| – | 24 V $\overline{=}$ /4.4 mA | 24 V $\overline{=}$ /4.4 mA | 24 V $\overline{=}$ /4.4 A max. |
| – | Sink (1) | Sink (1) | Sink (1) |
| – | Type 1 | Type 1 | Type 1 |

| | | | |
|-----------------------|-----------------------|-----------------------|-----------------------|
| 24 V $\overline{=}$ | 24 V $\overline{=}$ | 24 V $\overline{=}$ | 24 V $\overline{=}$ |
| Transistor/Source (2) | Transistor/Source (2) | Transistor/Source (2) | Transistor/Source (2) |
| 2 A max. | 0.5 A max. | 0.5 A max. | 0.5 A max. |
| 8 A max. | 4 A max. | 8 A max. | 8 A max. |

| | | | |
|--|--|--|--|
| 24 V $\overline{=}$ | 24 V $\overline{=}$ | 24 V $\overline{=}$ | 24 V $\overline{=}$ |
| 500 mA for all channels | 500 mA for all channels | 500 mA for all channels | 500 mA for all channels |
| Overloads, short-circuits and reverse polarity | Overloads, short-circuits and reverse polarity | Overloads, short-circuits and reverse polarity | Overloads, short-circuits and reverse polarity |

| | | | |
|--|--|--|--|
| B-coded 4-way male M12 | B-coded 4-way male M12 | B-coded 4-way male M12 | B-coded 4-way male M12 |
| B-coded 4-way female M12 | B-coded 4-way female M12 | B-coded 4-way female M12 | B-coded 4-way female M12 |
| – | 3-way female M8, 1 channel per connector | A-coded 5-way female M12, 2 channels per connector | 3-way female M8, 1 channel per connector |
| 3-way female M8, 1 channel per connector | 3-way female M8, 1 channel per connector | 5-way female M12, 2 channels per connector | 3-way female M8, 1 channel per connector |
| 4-way male M8 | 4-way male M8 | 4-way male M8 | 4-way male M8 |
| 4-way female M8 | 4-way female M8 | 4-way female M8 | 4-way female M8 |

| | | | |
|-----|-----|-----|-----|
| Yes | Yes | Yes | Yes |
| Yes | Yes | Yes | Yes |
| Yes | Yes | Yes | Yes |

Type of expansion block

| | | | |
|-------------------|-----------------|------------------|------------------|
| TM7BDO8TAB | TM7BDM8B | TM7BDM16A | TM7BDM16B |
|-------------------|-----------------|------------------|------------------|

| |
|------|
| 3/69 |
|------|

Expansion modules

Modicon TM7 blocks

Digital blocks for Modicon M258 logic controller and Modicon LMC058 motion controller

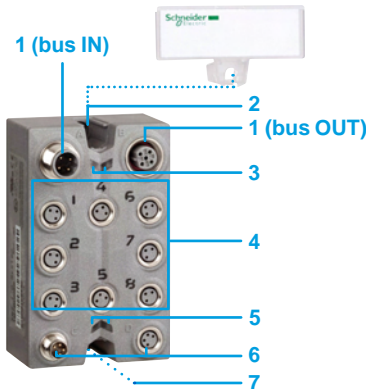

Description

Digital I/O expansion blocks

8-channel digital I/O expansion blocks have the following on the front panel:

- 1 A male M12 connector (bus IN) and a female M12 connector (bus OUT) for connecting the TM7 expansion bus
- 2 A slot for the expansion block label (1)
- 3 Two bus diagnostic LEDs
- 4 Eight female M8 connectors for connecting sensors and actuators with LEDs for indicating channel status
- 5 Two LEDs indicating the status of the sensor and actuator 24 V $\overline{\text{---}}$ power supplies
- 6 Two M8 connectors for connecting the 24 V $\overline{\text{---}}$ sensor and actuator power supplies: male for PWR IN, female for PWR OUT
- 7 Fixing using two \varnothing 4 screws (not supplied) and connection of the functional earth when fixing the block on a metal support

3

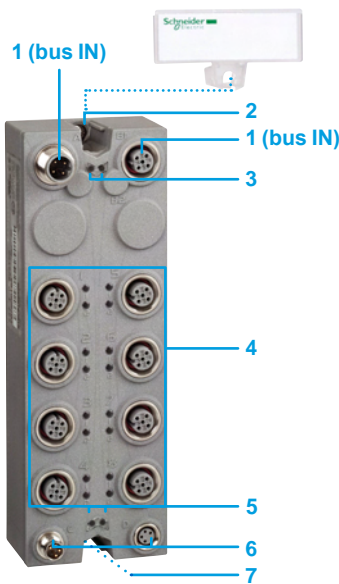

16-channel digital I/O expansion blocks have the following on the front panel:

- 1 A male M12 connector (bus IN) and a female M12 connector (bus OUT) for connecting the TM7 expansion bus
- 2 A slot for the expansion block label (1)
- 3 Two bus diagnostic LEDs
- 4 Eight M12 connectors (2 channels per connector) or sixteen M8 connectors for connecting sensors and actuators with LEDs for indicating channel status
- 5 Two LEDs indicating the status of the sensor and actuator 24 V $\overline{\text{---}}$ power supplies
- 6 Two M8 connectors for connecting the 24 V $\overline{\text{---}}$ sensor and actuator power supplies: male for PWR IN, female for PWR OUT
- 7 Fixing using two \varnothing 4 screws (not supplied) and connection of the functional earth when fixing the block on a metal support

(1) Label-holder supplied with IP 67 block.

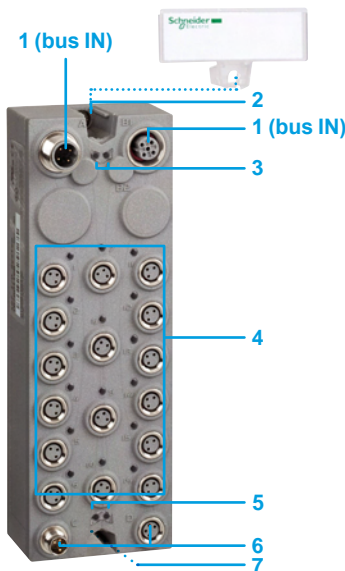

Expansion modules

Modicon TM7 blocks

Digital blocks for Modicon M258 logic controller and Modicon LMC058 motion controller



TM7BDI8B,
TM7BDO8TAB,
TM7BDM8B



TM7BDM16B,
TM7BDI16B



TM7BDI16A,
TM7BDM16A

Digital I/O expansion blocks

| Max. no. of channels | Number, type of inputs (1) | Number, type of outputs (2) | Sensor and actuator connection | Communication bus | Reference | Weight kg/lb |
|----------------------|----------------------------|--|--------------------------------|-------------------|-------------------|-----------------|
| 8 input | 8, sink (3) | – | 8 x female M8 connectors | TM7 bus | TM7BDI8B | 0.180/ 0.397 |
| 16 input | 16, sink (3) | – | 16 x female M8 connectors | TM7 bus | TM7BDM16B | 0.320/ 0.705 |
| | 16, sink (3) | – | 8 x female M12 connectors | TM7 bus | TM7BDI16A | 0.320/ 0.705 |
| 8 output | – | 8, transistor/ source (4), 2 A max. | 8 x female M8 connectors | TM7 bus | TM7BDO8TAB | 0.185/ 0.408 |
| 8 configurable I/O | 0...8, sink (3) | 0...8, transistor/ source (4), 0.5 A max. | 8 x female M8 connectors | TM7 bus | TM7BDM8B | 0.190/ 0.419 |
| 16 configurable I/O | 0...16, sink (3) | 0...16, transistor/ source (4), 0.5 A max. | 8 x female M12 connectors | TM7 bus | TM7BDM16A | 0.320/ 0.705 |
| | | | 16 x female M8 connectors | TM7 bus | TM7BDM16B | 0.320/ 0.705 |

(1) 24 V $\overline{---}$ IEC type 1

(2) 24 V $\overline{---}$

(3) Sink inputs: positive logic

(4) Source outputs: positive logic

Architecture, Connecting cables

See page 4/34

Connection accessories

See page 4/36

Separate parts

See page 4/37

Configuration software

■ SoMachine software, see page 5/2

■ Performance distributed I/O configuration software, please refer to our website www.schneider-electric.com

Expansion modules

Modicon TM7 blocks
Analog blocks for Modicon M258 logic controller and
Modicon LMC058 motion controller

Applications

Analog I/O expansion blocks



| Degree of protection | | IP 67 | IP 67 | IP 67 | |
|---------------------------------|--------------------------------|--|--|--|--------------------------|
| Type of housing | | Plastic | Plastic | Plastic | |
| Modularity (number of channels) | Max. number of analog channels | 4 | 4 | 4 | |
| | Analog inputs | 4 | 4 | – | |
| | Temperature inputs | – | – | 4 | |
| | Analog outputs | – | – | – | |
| Inputs | Type | Voltage - 10...+ 10 V \dots | Current 0...20 mA | Pt 100 temperature probe, Pt 1000 temperature probe, KTY 10 silicon temperature probe, KTY 84 silicon temperature probe, Resistance 0...3276 Ohm | |
| | Resolution | 11 bits + sign | 12 bits | 16 bits | |
| Analog outputs | Type | – | – | – | |
| | Resolution | – | – | – | |
| | Current per expansion block | – | – | – | |
| Sensor/actuator power supply | Voltage | 24 V \dots | 24 V \dots | – | |
| | Max. current | 500 mA for all channels | 500 mA for all channels | – | |
| | Protection against | Overloads, short-circuits and reverse polarity | Overloads, short-circuits and reverse polarity | – | |
| Connection | TM7 expansion bus | Bus input connector | 4-way male M12 B-coded | 4-way male M12 B-coded | 4-way male M12 B-coded |
| | | Bus output connector | 4-way female M12 B-coded | 4-way female M12 B-coded | 4-way female M12 B-coded |
| | Analog I/O channels | Sensor connector | 5-way female M12 A-coded | 5-way female M12 A-coded | 5-way female M12 A-coded |
| | | Actuator connector | – | – | – |
| | Expansion block power supply | Input connector | 4-way male M8 | 4-way male M8 | 4-way male M8 |
| | | Output connector | 4-way female M8 | 4-way female M8 | 4-way female M8 |
| Diagnostics | By expansion block | Yes | Yes | Yes | |
| | By channel | Yes | Yes | Yes | |
| | By communication on TM7 bus | Yes | Yes | Yes | |
| Type of expansion block | | TM7BAI4VLA | TM7BAI4CLA | TM7BAI4TLA | |
| Pages | | 3/72 | | | |

| Degree of protection | | IP 67 | IP 67 | IP 67 | IP 67 | IP 67 | |
|---------------------------------|--------------------------------|--|--|--|--|--|--------------------------|
| Type of housing | | Plastic | Plastic | Plastic | Plastic | Plastic | |
| Modularity (number of channels) | Max. number of analog channels | 4 | 4 | 4 | 4 | 4 | |
| | Analog inputs | – | – | – | 2 | 2 | |
| | Temperature inputs | – | – | – | – | – | |
| | Analog outputs | – | 4 | 4 | 2 | 2 | |
| Inputs | Type | J, K, S thermocouple Voltage 0...65536 μ V | – | – | Voltage - 10...+ 10 V \dots | Current 0...20 mA | |
| | Resolution | 16 bits | – | – | 11 bits + sign | 12 bits | |
| Analog outputs | Type | – | Voltage - 10...+ 10 V \dots | Current 0...20 mA | Voltage - 10...+ 10 V \dots | Current 0...20 mA | |
| | Resolution | – | 11 bits + sign | 12 bits | 11 bits + sign | 12 bits | |
| | Current per expansion block | – | – | – | – | – | |
| Sensor/actuator power supply | Voltage | – | 24 V \dots | 24 V \dots | 24 V \dots | 24 V \dots | |
| | Max. current | – | 500 mA for all channels | 500 mA for all channels | 500 mA for all channels | 500 mA for all channels | |
| | Protection against | – | Overloads, short-circuits and reverse polarity | Overloads, short-circuits and reverse polarity | Overloads, short-circuits and reverse polarity | Overloads, short-circuits and reverse polarity | |
| Connection | TM7 expansion bus | Bus input connector | 4-way male M12 B-coded | 4-way male M12 B-coded | 4-way male M12 B-coded | 4-way male M12 B-coded | |
| | | Bus output connector | 4-way female M12 B-coded | 4-way female M12 B-coded | 4-way female M12 B-coded | 4-way female M12 B-coded | 4-way female M12 B-coded |
| | Analog I/O channels | Sensor connector | A-coded 5-way female M12 | – | – | A-coded 5-way female M12 | A-coded 5-way female M12 |
| | | Actuator connector | – | A-coded 5-way female M12 | A-coded 5-way female M12 | A-coded 5-way female M12 | A-coded 5-way female M12 |
| | Expansion block power supply | Input connector | 4-way male M8 | 4-way male M8 | 4-way male M8 | 4-way male M8 | 4-way male M8 |
| | | Output connector | 4-way female M8 | 4-way female M8 | 4-way female M8 | 4-way female M8 | 4-way female M8 |
| Diagnostics | By expansion block | Yes | Yes | Yes | Yes | Yes | |
| | By channel | Yes | Yes | Yes | Yes | Yes | |
| | By communication on TM7 bus | Yes | Yes | Yes | Yes | Yes | |
| Type of expansion block | | TM7BAI4PLA | TM7BAO4VLA | TM7BAO4CLA | TM7BAM4VLA | TM7BAM4CLA | |
| Pages | | 3/72 | | | | | |

Expansion modules

Modicon TM7 blocks

Analog blocks for Modicon M258 logic controller and Modicon LMC058 motion controller

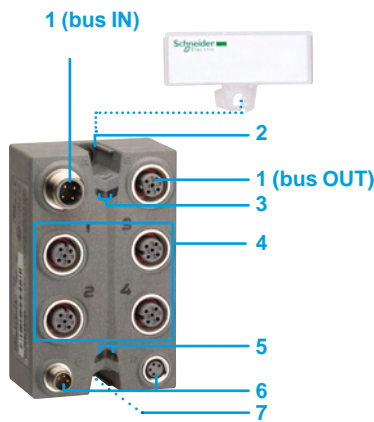

Description

Analog I/O expansion blocks

Analog I/O expansion blocks have the following on the front panel:

- 1 A male M12 connector (bus IN) and a female M12 connector (bus OUT) for connecting the TM7 expansion bus
- 2 A slot for the expansion block label (1)
- 3 Two bus diagnostic LEDs
- 4 Four female M12 connectors for connecting sensors and/or actuators with LEDs for indicating channel status
- 5 Two LEDs indicating the status of the sensor and actuator 24 V $\bar{\text{---}}$ power supplies
- 6 Two M8 connectors for connecting the 24 V $\bar{\text{---}}$ sensor and actuator power supplies: male for PWR IN, female for PWR OUT
- 7 Fixing using two \varnothing 4 screws (not supplied) and connection of the functional earth when fixing the block on a metal support

(1) Label-holder supplied with IP 67 block.

3

Analog I/O expansion blocks

| Max. no. of channels | Input range | Output range | Resolution | Sensor and actuator connection | Communication bus | Reference | Weight kg/lb |
|-----------------------|---|---|----------------|--------------------------------|-------------------|-------------------|-----------------|
| 4 input | Voltage | – | 11 bits + sign | 4 female M12 connectors | TM7 bus | TM7BAI4VLA | 0.200/ 0.441 |
| | Current 0...20 mA | – | 12 bits | 4 female M12 connectors | TM7 bus | TM7BAI4CLA | 0.200/ 0.441 |
| | Pt 100, Pt 1000 temperature probe KTY 10, KTY 84 silicon temperature probe Resistance 0...3276 Ω | – | 16 bits | 4 female M12 connectors | TM7 bus | TM7BAI4TLA | 0.200/ 0.441 |
| | J, K, S thermocouple Voltage 0...65536 μ V | – | 16 bits | 4 female M12 connectors | TM7 bus | TM7BAI4PLA | 0.200/ 0.441 |
| 4 output | – | Voltage - 10...+ 10 V $\bar{\text{---}}$ | 11 bits + sign | 4 female M12 connectors | TM7 bus | TM7BAO4VLA | 0.200/ 0.441 |
| | – | Current 0...20 mA | 12 bits | 4 female M12 connectors | TM7 bus | TM7BAO4CLA | 0.200/ 0.441 |
| 2 input + 2 output | Voltage - 10...+ 10 V $\bar{\text{---}}$ | Voltage - 10...+ 10 V $\bar{\text{---}}$ | 11 bits + sign | 4 female M12 connectors | TM7 bus | TM7BAM4VLA | 0.200/ 0.441 |
| | Current 0...20 mA | Current 0...20 mA | 12 bits | 4 female M12 connectors | TM7 bus | TM7BAM4CLA | 0.200/ 0.441 |



TM7BAI4●LA,
TM7BAO4●LA,
TM7BAM4●LA

Architecture, Connecting cables

See page 4/38

Connection accessories

See page 4/40

Separate parts

See page 4/41

Configuration software

- SoMachine software, see page 5/2
- Performance distributed I/O configuration software, please refer to our website www.schneider-electric.com

Expansion modules

Modicon TM7 blocks

Power distribution block for Modicon M258 logic controller and Modicon LMC058 motion controller

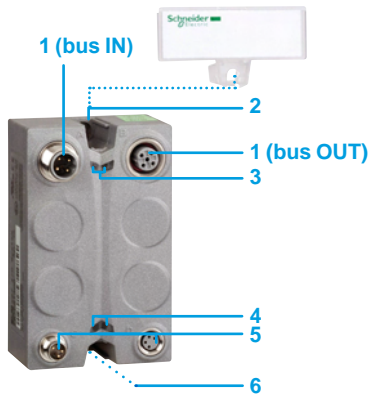

TM7SPS1A

Description

Power distribution block

The power distribution block has the following on the front panel:

- 1 A male M12 connector (bus IN) and a female M12 connector (bus OUT) for connecting the TM7 expansion bus
- 2 A slot for the power distribution block label (1)
- 3 Two TM7 bus diagnostic LEDs
- 4 Two LEDs indicating the status of the sensor and actuator 24 V $\overline{\text{---}}$ power supplies
- 5 Two M8 connectors for connecting the 24 V $\overline{\text{---}}$ sensor and actuator power supplies: male for PWR IN, female for PWR OUT
- 6 Fixing using two $\varnothing 4$ screws (not supplied) and connection of the functional earth when fixing the block on a metal support

(1) Label-holder supplied with IP 67 block.

Power distribution block

| Function | Connection | Communication bus | Reference | Weight kg/ lb |
|---|--|-------------------|-----------|---------------------|
| 24 V $\overline{\text{---}}$ /15 W power supply for I/O expansion blocks on the TM7 expansion bus | Supply: 2xM8 connectors, 1 male and 1 female TM7 bus: 2xM12 connectors, 1 male and 1 female | TM7 bus | TM7SPS1A | 0.190/ 0.419 |

Architecture, Connecting cables

See page 4/38

Connection accessories

See page 4/40

Separate parts

See page 4/41

Configuration software

- SoMachine software, see page 5/2
- Performance distributed I/O configuration software, please refer to our website www.schneider-electric.com

chapter 4

Communication



All technical information about products listed in this chapter are available on www.schneider-electric.com

- **Profibus**
 - Modicon TM5 Profibus module 4/2
 - Modicon TM4 Profibus module 4/40

- **Serial links (Modbus protocols, character mode)**
 - Modicon M221 and M221 Book logic controllers 4/4
 - Modicon M241 and M251 logic controllers 4/6
 - Modicon M258 logic controller and Modicon LMC058 motion controller 4/8
 - Modicon TM5 communication modules 4/10

- **CANopen**
 - Modicon M241 and Modicon M251 logic controllers 4/12
 - **CANopen Optimized architecture with Modicon OTB**
 - > Presentation 4/14
 - > Altivar IMC drive controller 4/15
 - > Magelis XBTGC HMI controllers and XBTGT/GK with control function 4/16
 - > Modicon OTB (IP 20) 4/18
 - > Architecture 4/20
 - **CANopen Performance architecture with Modicon TM5 / TM7**
 - > Presentation 4/22
 - > Modicon M258 logic controller and Modicon LMC058 motion controller 4/23
 - > Distributed I/O on CANopen bus with Modicon TM5 interface module (IP 20) 4/24
 - > Distributed I/O on CANopen bus with Modicon TM7 interface blocks (IP 67) 4/28
 - > CANopen Performance architecture 4/38

- **Ethernet Modbus/TCP network**
 - Modicon TM4 Ethernet module 4/40
 - Modicon M221, M241 and M251 logic controllers and TM4ES4 Ethernet switch module 4/42
 - Modicon M258 logic controller, Modicon LMC058 motion controller, XBTGT/GK with control function, Altivar IMC drive controller 4/48

Communication

Modicon TM5 communication module
for connection to the Profibus DP fieldbus
for Modicon M258 logic controllers and Modicon LMC058 motion
controllers

Presentation

Profibus DP (Decentralized Peripherals)

Profibus (Process Field Bus) is a fieldbus for controlling decentralized sensors, actuators or PLCs via a central master controller.

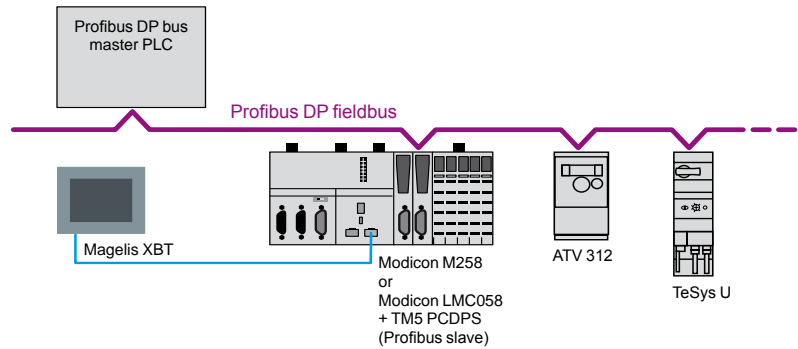

Connectable devices

The following Schneider Electric devices can be connected to this bus:

- Modicon TM258LD42DT4L, TM258LF42DT4L, TM258LF42DR and TM258LF66DT4L logic controllers equipped with the **TM5PCDPS** communication module
 - Modicon LMC 058LF42 and LMC 058LF424 motion controllers equipped with the **TM5PCDPS** communication module
 - TeSys U and TeSys T starter-controllers
 - Momentum and Modicon STB distributed I/O
 - Altivar 312/61/71 variable speed drives for asynchronous motors
 - Lexium 05 and 15 servo drives for brushless motors
 - Altistart ATS 48 soft start-soft stop units
- And any third-party device compatible with Profibus DP standard profiles.

Profibus communication module

The **TM5PCDPS** communication module is designed for **TM258LD42DT4L**, **TM258LF42DT4L**, **TM258LF42DR** and **TM258LF66DT4L** logic controllers and **LMC058LF424** motion controllers and is installed in one of the two free PCI slots.

The **TM5PCDPS** communication module is used to configure the connection as a slave on the Profibus DP fieldbus.

Note: The maximum number of communication modules is two (see page 4/10) with a single **TM5PCDPS** Profibus DP slave communication module.

Description

The **TM5PCDPS** communication module features:

- 1 A locking clip for mounting/removing the module onto/from the logic controller or motion controller
- 2 A LED display block for the module channels and diagnostics
- 3 A connector for linking the logic controller or motion controller
- 4 A SUB-D connector (male 9-way) for connection to the Profibus fieldbus

4

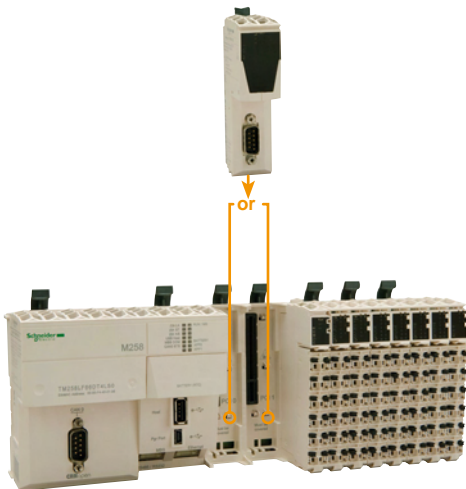

TM5PCDPS communication module: For mounting on one of the two free PCI slots on an M258 controller or LMC058 motion controller

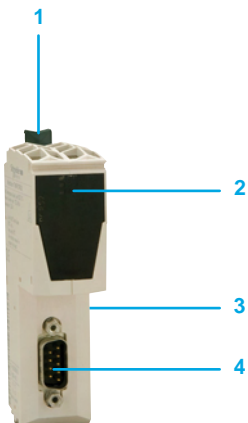

Communication

Modicon TM5 communication module for connection to the Profibus DP fieldbus

for Modicon M258 logic controllers and Modicon LMC058 motion controllers



TM5PCDPS



490NAD91103

References

Modicon TM5 communication module

| Description | For use with | Profile | Built-in port | Reference | Weight kg/ lb |
|--|--|----------|---------------------------------|-----------------|---------------------|
| Communication module for Profibus DP (244 I/O data bits) | Logic controllers: | V1 slave | SUB-D connector (male 9-way) | TM5PCDPS | 0.064/ 0.141 |
| | <input type="checkbox"/> TM258LD42DT4L <input type="checkbox"/> TM258LF42DT4L <input type="checkbox"/> TM258LF42DR <input type="checkbox"/> TM258LF66DT4L | | | | |
| | Motion controllers: | | | | |
| | <input type="checkbox"/> LMC058LF42 <input type="checkbox"/> LMC058LF424 | | | | |

Profibus DP fieldbus connection components

| Description | Length m/ ft | Item no. | Reference | Weight kg/ lb |
|--------------------------------------|--------------------|----------|--------------------|---------------------|
| Profibus DP connection cables | 100/ 328.08 | 1 | TSXPBSCA100 | – |
| | 400/ 1312.33 | 1 | TSXPBSCA400 | – |

| Description | Type | Item no. | Reference | Weight kg/ lb |
|---|--------------------------------------|----------|--------------------|---------------------|
| Remote I/O on Profibus DP fieldbus | Modicon STB network interface module | – | STBNDP2212 | 0.140/ 0.309 |
| Connectors for remote I/O communication module | Line terminator | – | 490NAD91103 | – |
| | In-line connector | – | 490NAD91104 | – |
| | In-line connector and terminal port | – | 490NAD91105 | – |

Presentation

RS 232/RS 485 serial links offer a simple solution to the communication needs of compact machines.

Modbus and ASCII standard communication protocols are used to connect numerous equipment items such as: HMIs, printers, energy meters, variable speed drives, motor starters, remote I/O (RIO), etc.

Description

Modicon M221 logic controllers with 16, 24 or 40 I/O have the following on the front panel:

- 1 A serial link port with an RJ45 connector delivering a voltage of 5 V (200 mA) to supply an HMI or Bluetooth® adaptor with power.
- 2 A slot for a 2nd serial link port (with connection on screw terminals) by inserting the **TMC2SL1** communication cartridge or the **TMC2CONV01** application cartridge (1).

Modicon M221 Book logic controllers with 16 or 32 I/O have the following on the front panel:

- 3 A serial link port with an RJ45 connector delivering a voltage of 5 V (200 mA) to supply an HMI or Bluetooth® adaptor with power.
- 4 A 2nd serial port also equipped with an RJ45 connector for **TM221M16●●** and **TM221M32●●** controllers (controllers without embedded Ethernet).



TM221C●●●●



TM221M16●●
TM221M32●●



TM221ME●●●●

| Controller Type | Embedded Ports | | Optional Port (1 max. per controller) |
|-----------------|---|------------------------------------|--|
| | "Serial" or "Serial 1" port, RJ45 connector | "Serial 2" port, RJ45 connector | |
| TM221C●●●● | RS 232/RS 485 with 5 V (200 mA) power supply for HMI or Bluetooth communication adaptor (items 1/3) | – | RS 232/RS 485 (item 2) |
| TM221M●●●● | RS 485 (item 4) | RS 485 (item 4) | – |
| TM221ME●●●● | | – | – |

(1) TM221C40●●●● controllers have 2 slots for a cartridge; only one cartridge, TMC2SL1 or TMC2CONV01, can be used per controller. The other slot remains available for an analog I/O cartridge or an application cartridge.

Modbus serial link wiring system

Non-isolated bus

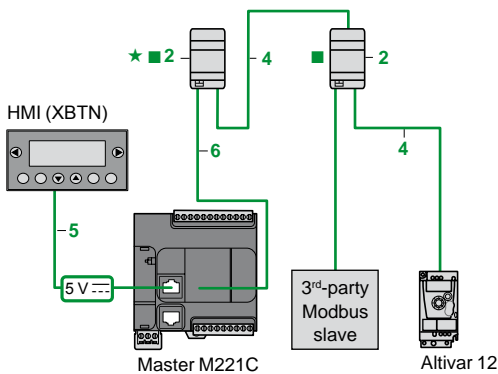

Isolated bus (recommended for bus > 10 m/32.808 ft)

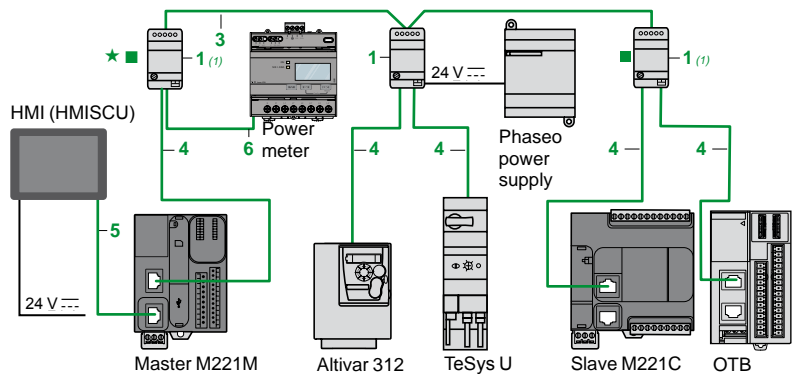

- Total length of cables between M221 and ATV 12: ≤ 30 m (98.425 ft)

- Length of cable 4: ≤ 10 m (32.808 ft)

★ Line polarization active. ■ Line termination





- Total length of cables between isolation boxes 1: ≤ 1000 m (3280.840 ft)

- Length of drop cables 4 or 5: ≤ 10 m (32.808 ft)

★ Line polarization active. ■ Line termination

(1) Box powered by the logic controller.

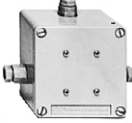
References

| Tap-off and adaptor components for RS 485 serial link | | | | | | | |
|---|--|---|--------------------|-----------------|---------------------|-------------------|--|
| Designation | Description | Item | Length m/ ft | Unit reference | Weight kg/ lb | | |
|  TWDXCAISO | T-junction and isolation box Screw terminals for trunk cable 2 x RJ45 for tap-off | <input type="checkbox"/> Isolation of the RS 485 link (1) <input type="checkbox"/> Line termination (RC 120 Ω, 1nF) <input type="checkbox"/> Line pre-polarization (2 R 620 Ω) <input type="checkbox"/> 24 V $\overline{\text{---}}$ power supply (screw terminals) or 5 V $\overline{\text{---}}$ power supply (via RJ45) <input type="checkbox"/> Mounting on 35 mm (1.378 in.) \perp | 1 | – | TWDXCAISO | 0.100/ 0.220 | |
| | T-junction box 1 x RJ45 for trunk cable 2 x RJ45 for tap-off | <input type="checkbox"/> Line termination (RC 120 Ω, 1nF) <input type="checkbox"/> Line pre-polarization (2 R 620 Ω) <input type="checkbox"/> Mounting on 35 mm (1.378 in.) \perp | 2 | – | TWDXCAT3RJ | 0.080/ 0.176 | |
|  TWDXCAT3RJ | Modbus splitter box Screw terminals for trunk cable 10 x RJ45 for tap-off | <input type="checkbox"/> Mounting on 35 mm (1.378 in.) \perp , on plate or panel | – | – | LU9GC3 | 0.500/ 1.102 | |
| | T-junctions 2 x RJ45 for trunk cable | 1 integrated cable with RJ45 connector for tap-off dedicated to Altivar variable speed drive | – | 0.3/ 0.98 | VW3A8306TF03 | – | |
| | | | 1/ 3.28 | VW3A8306TF10 | – | | |
| | Passive T-junction box | <input type="checkbox"/> 1-channel line extension and tap-off on screw terminals <input type="checkbox"/> Line termination | – | – | TSXSCA50 | 0.520/ 1.146 | |
|  XGSZ24 | RS 232C/RS 485 line converter | <input type="checkbox"/> Max. data rate 19.2 Kbps, No modem signals <input type="checkbox"/> 24 V $\overline{\text{---}}$ /20 mA power supply <input type="checkbox"/> Mounting on 35 mm (1.378 in.) \perp | – | – | XGSZ24 | 0.100/ 0.220 | |
| | Cables and cordsets for RS 232 serial link | | | | | | |
|  LU9GC3 | RS 485 double shielded twisted pair trunk cables | Modbus serial link, supplied without connector | 3 | 100/ 328.06 | TSXCSA100 | 5.680/ 12.522 | |
| | | | | 200/ 656.16 | TSXCSA200 | 10.920/ 24.074 | |
| | | | | 500/ 1640.42 | TSXCSA500 | 30.000/ 66.139 | |
| | | | | | | | |
|  TSXSCA50 | Modbus RS 485 cordsets | 2 x RJ45 connectors | 4 | 0.3/ 0.98 | VW3A8306R03 | 0.030/ 0.066 | |
| | | | | 1/ 3.28 | VW3A8306R10 | 0.050/ 0.110 | |
| | | | | 3/ 9.84 | VW3A8306R30 | 0.150/ 0.331 | |
| | | 1 x RJ45 connector and 1 end with flying leads | 6 | 1/ 3.28 | TWDXCAFJ010 | 0.060/ 0.132 | |
| | | | | 3/ 9.843 | VW3A8306D30 | 0.150/ 0.331 | |
| | | | | | | | |
|  XGSZ24 | Controller to Magelis HMI cordsets | 2 x RJ45 connectors | 5 | 2.5/ 8.20 | XBTZ9980 | 0.230/ 0.507 | |
| | | Compatible with: | 5 | 10/ 32.81 | XBTZ9982 | – | |
| | | <input type="checkbox"/> Com Port 1 on XBTN200/N400/R400/RT500 (2) <input type="checkbox"/> Com Port 1 on XBTRT511/HMISTO/STU/SCU <input type="checkbox"/> Com Port 2 on XBTGT2●●0...7●●0 and HMIGTO | | | | | |
| | | 1 x RJ45 connector and 1 x 25-way SUB-D connector | – | 2.5/ 8.20 | XBTZ938 | 0.210/ 0.463 | |
| | | Compatible with: | | | | | |
| | | <input type="checkbox"/> Com Port 1 on XBTN410/N410 and XBTR410/R411 | | | | | |
| | 1 x RJ45 connector and 1 x 9-way SUB-D connector | – | 2.5/ 8.20 | XBTZ9008 | – | | |
| | Compatible with: | | | | | | |
| | <input type="checkbox"/> Com Port 1 on XBTGT2●●0...7●●0 | | | | | | |
| | TMC2SL1 cartridge to Magelis HMI cordsets | 1 x RJ45 connector and stripped wires | – | 3/ 9.84 | VW3A8306D30 | 0.150/ 0.331 | |
| | Compatible with: | | | | | | |
| | <input type="checkbox"/> Com Port 1 on XBTRT511/HMISTO/STU/SCU <input type="checkbox"/> Com Port 2 on XBTGT2●●0...7●●0 and HMIGTO | | | | | | |
| | Line end adaptor Sold in packs of 2 | For RJ45 connector R = 120 Ω, C = 1 nf | – | – | VW3A8306RC | 0.200/ 0.441 | |
| Cordsets for RS 232 serial link | | | | | | | |
| | Cordset for DTE terminal (printer) (3) | Serial link for Data Terminal Equipment (DTE) 1 x RJ45 connector and 1 x 9-way female SUB-D connector | | 3/ 9.84 | TCSCMCN3M4F3C2 | 0.150/ 0.331 | |
| | Cordset for DCE terminal (modem, converter) | Serial link for point to point device (DCE) 1 x RJ45 connector and 1 x 9-way male SUB-D connector | | 3/ 9.84 | TCSCMCN3M4M3S2 | 0.150/ 0.331 | |

(1) Line isolation recommended for line distances > 10 m (32.808 ft).

(2) Can only be connected to the controller SL or SL1 ports in order to supply the Magelis terminal with power.

(3) If the terminal is equipped with a 25-way SUB-D connector, you will also need to order the TSXCTC07 25-way female/9-way male SUB-D adaptor.

Presentation

RS 232/RS 485 serial links offer a simple solution to the communication needs of machines.
Modbus and ASCII standard communication protocols are used to connect numerous equipment items such as: HMIs, printers, energy meters, variable speed drives, motor starters, remote I/O (RIO), etc.

Description



Modicon **M241** logic controllers have the following on their upper surface:

- 1 A "Serial 1" serial link port with an RJ45 connector delivering a 5 V/200 mA power supply which allows the use of a Magelis HMI, the Bluetooth® communication adapter or other devices.
- 2 A 2nd "Serial 2" serial link port (with connection on screw terminals).

| Controller Type | Embedded Ports | |
|-------------------|---|--|
| | "Serial 1" port, RJ45 connector | "Serial 2" port, connection on screw terminals |
| TM241 ●●●● | RS 232/RS 485 with 5V (200 mA) power supply for HMI or Bluetooth communication adaptor (item 1) | RS 485 (item 2) |



Modicon **M251** logic controllers have on their front a serial link port with an RJ45 connector delivering a 5 V/200 mA power supply which allows the use of a Magelis HMI, the Bluetooth® communication adaptor or other devices.

- 3 A serial link port (RJ 45 connector (RS 232 or RS 485)).

Modbus serial link wiring system

Non-isolated bus

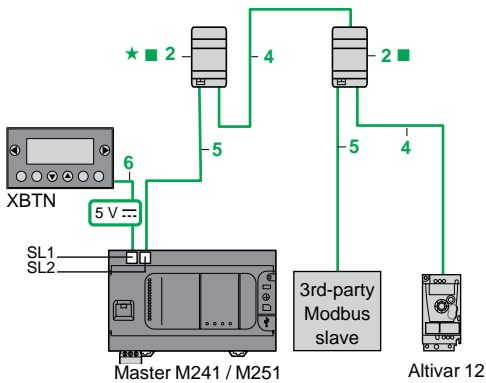

Isolated bus (recommended for bus > 10 m (32.808 ft))

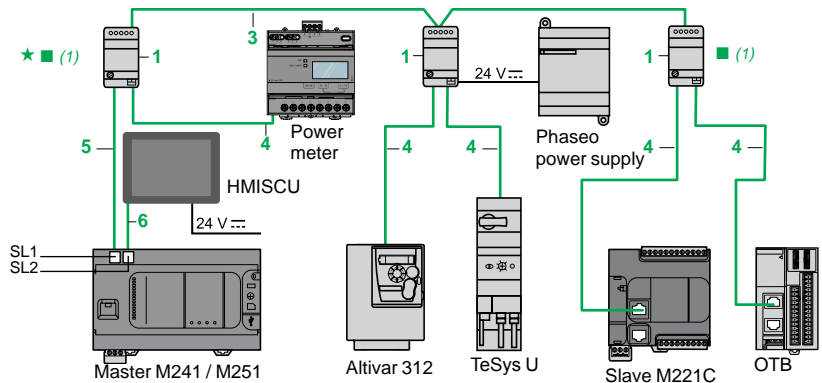

- Total length of cables between M241/M251 and ATV12: ≤ 30 m (98.425 ft)
- Length of cable 4: ≤ 10 m (32.808 ft)
- ★ Line polarization active. ■ Line termination

- Total length of cables between isolation boxes 1: ≤ 1000 m (3280.840 ft)
- Length of drop cables 4 or 5: ≤ 10 m (32.808 ft)
- ★ Line polarization active. ■ Line termination
- (1) Box powered by the logic controller.

References



TWDXCAISO TWDXCAT3RJ

Tap-off and adaptor components for RS 485 serial link

| Designation | Description | Item | Length m/ft | Unit reference | Weight kg/lb |
|--|---|------|-------------|----------------|-----------------|
| T-junction and isolation box Screw terminals for trunk cable 2 x RJ45 for tap-off | <input type="checkbox"/> Isolation of the RS 485 link (1) <input type="checkbox"/> Line termination (RC 120 Ω, 1nF) <input type="checkbox"/> Line pre-polarization (2 R 620 Ω) <input type="checkbox"/> 24 V power supply (screw terminals) or 5 V power supply (via RJ45) <input type="checkbox"/> Mounting on 35 mm (1.378 in.) | 1 | – | TWDXCAISO | 0.100/ 0.220 |
| T-junction box 1 x RJ45 for trunk cable 2 x RJ45 for tap-off | <input type="checkbox"/> Line termination (RC 120 Ω, 1nF) <input type="checkbox"/> Line pre-polarization (2 R 620 Ω) <input type="checkbox"/> Mounting on 35 mm (1.378 in.) | 2 | – | TWDXCAT3RJ | 0.080/ 0.176 |

(1) Line isolation recommended for line distances > 10 m (32.808 ft).

Communication

Modicon M241 and Modicon M251 logic controllers

Serial links (Modbus protocols, character mode)



LU9GC3



TSXSCA50



XGSZ24

References (continued)

| Designation | Description | Item | Length m/ft | Reference | Weight kg/ lb |
|--|--|----------|-----------------|----------------------|---------------------|
| Tap-off and adaptor components for RS 485 serial link | | | | | |
| Modbus splitter box | <input type="checkbox"/> Mounting on 35 mm (1.378 in.) \perp , on plate or panel <input type="checkbox"/> Screw terminals for trunk cable <input type="checkbox"/> 10 x RJ45 for tap-off | – | – | LU9GC3 | 0.500/ 1.102 |
| T-junctions | 1 integrated cable with RJ45 connector for tap-off | – | 0.3/ 0.98 | VW3A8306TF03 | – |
| | 2 x RJ45 for trunk cable | – | 1/ 3.28 | VW3A8306TF10 | – |
| Passive T-junction box | <input type="checkbox"/> 1-channel line extension and tap-off on screw terminals <input type="checkbox"/> Line termination | – | – | TSXSCA50 | 0.520/ 1.146 |
| RS 232C/RS 485 line converter | <input type="checkbox"/> Max. data rate 19.2 Kbps, No modem signals <input type="checkbox"/> 24 V $\overline{\text{---}}$ /20 mA power supply <input type="checkbox"/> Mounting on 35 mm (1.378 in.) | – | – | XGSZ24 | 0.100/ 0.220 |
| Cables and cordsets for RS 232 serial link | | | | | |
| RS 485 double shielded twisted pair trunk cables | Modbus serial link, supplied without connector | 3 | 100/ 328.08 | TSXCSA100 | 5.680/ 11.023 |
| | | | 200/ 656.16 | TSXCSA200 | 10.920/ 24.074 |
| | | | 500/ 1640.42 | TSXCSA500 | 30.000/ 66.139 |
| Modbus RS 485 cordsets | 2 x RJ45 connectors | 4 | 0.3/ 0.98 | VW3A8306R03 | 0.030/ 0.066 |
| | | | 1/ 3.28 | VW3A8306R10 | 0.050/ 0.110 |
| | | | 3/ 9.84 | VW3A8306R30 | 0.150/ 0.331 |
| | 1 x RJ 45 connector and 1 end with flying leads | 5 | 1/ 3.28 | TWDXCAFJ010 | 0.060/ 0.132 |
| | | | 3/ 9.84 | VW3A8306D30 | 0.150/ 0.331 |
| Cordsets: used from M241 (SL1), M251 controllers to Magelis HMI | 2 x RJ45 connectors | 6 | 2/ 8.20 | XBZT9980 | 0.230/ 0.507 |
| | Compatible with: | | | | |
| | <input type="checkbox"/> Com Port 1 on XBTN200/N400/R400/RT500 (1) | 6 | 10/ 32.81 | XBZT9982 | – |
| | <input type="checkbox"/> Com Port 1 on XBTRT511 and HMISTO/STU/SCU | | | | |
| | <input type="checkbox"/> Com Port 2 on XBTGT2●●0...7●●0 and HMIGTO | | | | |
| | 1 x RJ45 connector and 1 x 25-way SUB-D connector | – | 2.5/ 8.20 | XBZT9938 | 0.210/ 0.463 |
| | Compatible with: | | | | |
| | <input type="checkbox"/> Com Port 1 on XBTN410/N410 and XBTR410/R411 | | | | |
| | 1 x RJ45 connector and 1 x 9-way SUB-D connector | – | 2.5/ 8.20 | XBZT9008 | – |
| | Compatible with: | | | | |
| | <input type="checkbox"/> Com Port 1 on XBTGT2●●0...7●●0 | | | | |
| Cordsets: used from M241 (SL2) controllers to Magelis HMI | 1 x RJ45 connector and stripped wires | – | 3/ 9.84 | VW3A8306D30 | 0.150/ 0.331 |
| | Compatible with: | | | | |
| | <input type="checkbox"/> Com Port 1 on XBTRT511 and HMISTO/STU/SCU | | | | |
| | <input type="checkbox"/> Com Port 2 on XBTGT2●●0...7●●0 and HMIGTO | | | | |
| Line end adaptor | For RJ45 connector | – | – | VW3A8306RC | 0.200/ 0.441 |
| | Sold in packs of 2 R = 120 Ω , C = 1 nf | | | | |
| Cordsets for RS 232 serial link | | | | | |
| Cordset for DTE terminal (printer) (2) | Serial link for Data Terminal Equipment (DTE) 1 x RJ45 connector and 1 x 9-way female SUB-D connector | | 3/ 9.84 | TCSMCN3M4F3C2 | 0.150/ 0.331 |
| Cordset for DCE terminal (modem, converter) | Serial link for point to point device (DCE) 1 x RJ45 connector and 1 x 9-way male SUB-D connector | | 3/ 9.84 | TCSMCN3M4M3S2 | 0.150/ 0.331 |

(1) If the terminal is equipped with a 25-way SUB-D connector, you will also need to order the **TSXCTC07** 25-way female / 9-way male SUB-D adaptor.

(2) Can only be connected to the controller SL or SL1 ports in order to supply the Magelis terminal with power.

Modbus cabling system

Non-isolated link

(Modicon M258, LMC058 master)

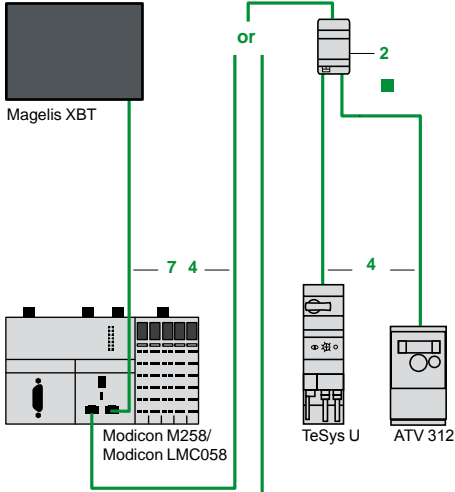

Isolated link

(Modicon M258, LMC058 master)

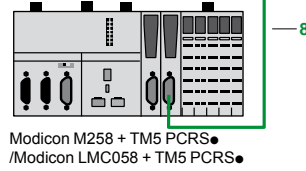
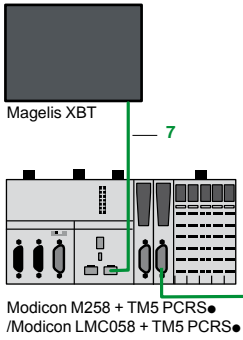
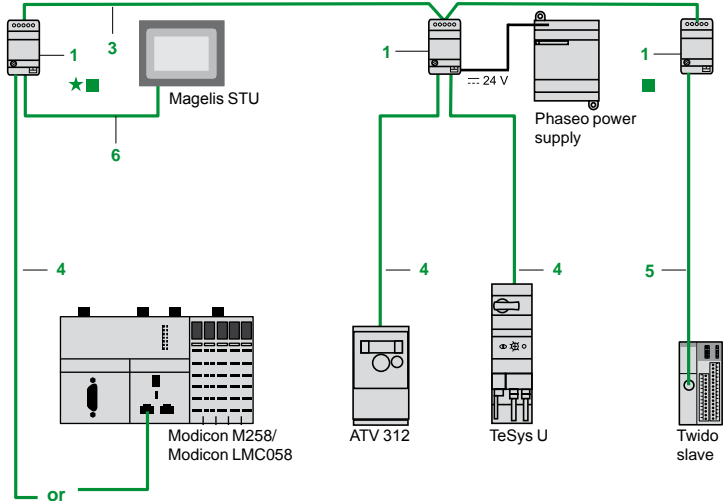

- Length of cables between Modicon M258 and Altivar:
 ≤ 30 m max.

- Total length of cables between isolation boxes 1: ≤ 1000 m
 - Length of tap cables 4, 5 or 6: ≤ 10 m

- ★ Line polarization active
- Line termination

4

References

Extension and adaptation elements, cables and cordsets for RS 485 serial link

| Designation | Description | No. | Length m/ft | Unit reference | Weight kg/lb |
|---|--|------|---|--|--|
| Isolation box Screw terminal block for trunk cable 2 x RJ45 connectors for tap-off | - Isolation of the RS485 link (1) - Line termination (RC 120 Ω, 1 nF) - Line pre-polarization (2 R 620 Ω), Power supply 24 V [DC symbol] (screw terminal block) or 5 V [DC symbol] (via RJ45), Mounting on 35 mm 1 | 1 | – | TWDXCAISO | 0.100/0.220 |
| Junction box 1 RJ45 for trunk cable 2 x RJ45 for tap-off | - Line termination (RC 120 Ω, 1 nF) - Line pre-polarization (2 R 620 Ω), Mounting on 35 mm 5 | 2 | – | TWDXCAT3RJ | 0.080/0.176 |
| Modbus splitter box Screw terminal block for trunk cable 10 x RJ45 for tap-off | Mounting on 35 mm 1 on plate or panel (2 x Ø 4 – mm screws) | – | – | LU9GC3 | 0.500/1.102 |
| T-junction boxes 2 x RJ45 for trunk cable | 1 integrated cable with RJ45 connector for tap-off – dedicated to Altivar variable speed drive | – | 0.3/0.98 1/3.28 | VW3A8306TF03 VW3A8306TF10 | – |
| Passive T-junction box | - 1-channel line extension and tap-off on screw terminal block - Line termination | – | – | TSXSACA50 | 0.520/1.146 |
| RS 232C/RS 485 line converter | - Max. data rate 19.2 Kbps - No modem signals 24 V 200 mA power supply, Mounting on 35 mm 1 | – | – | XGSZ24 | 0.100/0.220 |
| RS 485 double shielded twisted pair trunk cables | Modbus serial link, supplied without connector | 3 | 100/328.08 200/656.16 500/1640.41 | TSXCASA100 TSXCASA200 TSXCASA500 | 5.680/ 12.522 10.920/ 24.074 30.000/ 66.138 |
| Modbus RS 485 cordsets | 2 x RJ45 connectors | 4 | 0.3/0.98 1/3.28 3/9.84 | VW3A8306R03 VW3A8306R10 VW3A8306R30 | 0.030/0.066 0.050/0.110 0.150/0.331 |
| | 1 x RJ45 connector and 1 end with flying leads | – | 1/3.28 3/9.84 | TWDXCAFJ010 VW3A8306D30 | 0.060/0.132 0.150/0.331 |
| | 1 x mini-DIN connector for Twido controller and 1 x RJ45 connector | – | 0.3/0.98 1/3.28 3/9.84 | TWDXCARJ003 TWDXCARJ010 TWDXCARJ030 | 0.040/0.088 0.090/0.198 0.160/0.353 |
| | 1 x mini-DIN connector for Twido controller and 1 x RJ45 connector (2) (3) | 5 | 0.3/0.98 | TWDXCARJP03 | 0.027/0.060 |
| | 1 x mini-DIN connector for Twido controller and 1 x RJ45 connector Dedicated to Programming protocol (3) (4) | – | 0.3/0.98 | TWDXCARJP03P | 0.027/0.060 |
| | 1 mini-DIN connector for Twido controller and 1 end with flying leads | – | 1/3.28 10/32.81 | TWDXCAF010 TSXCX100 | 0.062/0.137 0.517/1.140 |
| Cordsets Modicon M258 (SL1, SL2) to Magelis display unit and terminal | 2 x RJ45 connectors | 7 | 2.5/8.20 | XBTN200/R400 XBTRT500/511 XBTGT11●●/1335 | 0.150/0.331 |
| | 1 x RJ45 connector and 1 x 25-way SUB-D connector | 6, 7 | 2.5/8.20 | XBTN401/410 XBTR410/411 | 0.210/0.463 |
| | 1 x RJ45 connector and 1 x 9-way SUB-D connector | 7 | 2.5/8.20 | Advanced Panel XBTGT2●●0...7340 XBTGK●●●0 | 0.150/0.331 |
| Cordset for Magelis Small Panel display unit and terminal | 2 x RJ45 connectors | 6 | 3/9.84 | Small Panel XBT N200/R400 XBTRT500/511 | 0.150/0.331 |
| Line terminator | For RJ45 connector R = 120 Ω, C = 1 nf Sold in lots of 2 | – | – | VW3A8306RC | 0.200/0.441 |

Cordsets for RS 232 serial link

| Designation | Description | No. | Length m/ft | Reference | Weight kg/lb |
|--|--|-----|----------------|---------------|-----------------|
| Cordset for DTE terminal (printer) (5) | Serial link for DTE equipment (2) 1 x RJ45 connector and 1 x 9-way female SUB-D connector | 8 | 3/9.84 | TCSMCN3M4F3C2 | 0.150/ 0.331 |
| Cordset for DCE terminal (modem, converter) | Serial link for DCE 1 x RJ45 connector and 1 x 9-way male SUB-D connector | 8 | 3/9.84 | TCSMCN3M4M3S2 | 0.150/ 0.331 |

(1) Line isolation recommended for line distances > 10 m.

(2) Forces configuration of the Twido controller built-in RS 485 port with the TwidoSuite programming protocol parameters.

(3) Carries the 5 V 200 mA voltage (supplied by the Twido controller built-in RS 485 port) required by the TWDXCAISO isolation box, thus avoiding the need for a 24 V 200 mA external power supply.

(4) Allows the Twido controller built-in RS 485 port to be used with the parameters described in the configuration.

(5) If the terminal is equipped with a 25-way SUB-D connector, you will also need to order the 25-way female/9-way male SUB-D adaptor TSXCTC07.



TWDXCAISO



TWDXCAT3RJ



LU9GC3

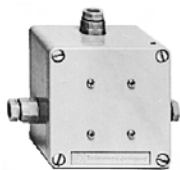

TSXSACA50



XGSZ24

Communication

Modicon TM5 communication modules for Modbus serial link

for Modicon M258 logic controller and Modicon LMC058 motion controller

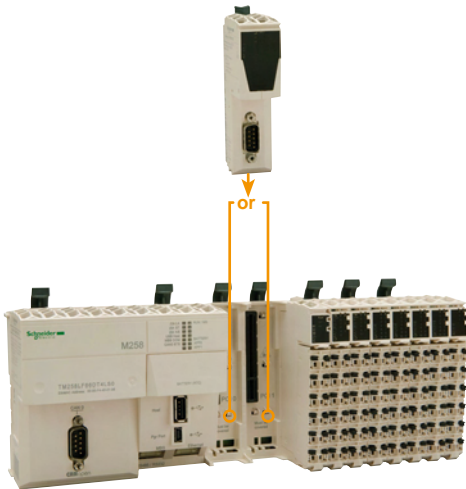

TM5 PCRS communication module: for mounting the two free PCI slots in the M258 logic controller or LMC058 motion controller

Presentation

TM5PCRS communication modules are designed for **TM258LD42DT4L**, **TM258LF42DT4L**, **TM258LF42DR**, **TM258LF66DT4L** logic controllers, **LMC058LF42** and **LMC058LF424** motion controllers and are installed in one of the two free PCI slots in.

TM5PC communication modules can be used to configure one or two additional Modbus or ASCII serial links as RS232 or RS485.

Nota: the maximum number of communication modules is 2.

Modbus and Character mode serial links

Cabling system: see page 4/8.

Description

TM5PCRS communication modules comprise:

- 1 A locking clip for mounting/dismounting on the controller
- 2 A channel and module diagnostics LED display block
- 3 A connector for linking to the controller
- 4 A SUB-D connector (male 9-way) for connection to the serial link

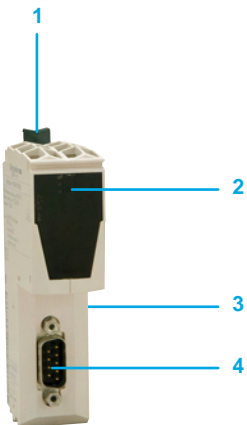

Serial link

| LED | Colour | Status: on |
|--------|--------|--|
| Status | Green | Operation in progress |
| | Red | Controller starting |
| RXD | Yellow | Reception on interface: <input type="checkbox"/> RS232 with TM258PCRS2 <input type="checkbox"/> RS485 with TM258PCRS4 |
| TXD | Yellow | Transmission on interface: <input type="checkbox"/> RS232 with TM258PCRS2 <input type="checkbox"/> RS485 with TM258PCRS4 |

Communication

Modicon TM5 communication modules for Modbus serial link

for Modicon M258 logic controller and Modicon LMC058 motion controller



TM5PCRS●

| References | | | | | |
|--|---|---------------------------------------|---------------------------------|-----------------|-----------------|
| Description | Used for | Physical layer/ protocols | Built-in port | Reference | Weight kg/lb |
| Modbus serial link communication modules | Logic controllers: <input type="checkbox"/> TM258 LD42DT4L, <input type="checkbox"/> TM258 LF42DT4L, <input type="checkbox"/> TM258 LF42DR, <input type="checkbox"/> TM258 LF66DT4L | RS232/ Modbus/ASCII, SoMachine | SUB-D connector (male 9-way) | TM5PCRS2 | 0.064/ 0.141 |
| | Motion controllers: <input type="checkbox"/> LMC 058LF42, <input type="checkbox"/> LMC 058LF424 | RS485 / Modbus/ASCII, SoMachine | SUB-D connector (male 9-way) | TM5PCRS4 | 0.064/ 0.141 |

Communication

CANopen architecture

for Modicon M241 and Modicon M251 logic controllers

4

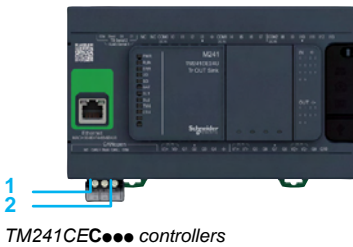

TM241CEC... controllers

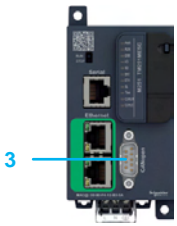

TM251MES controller

Presentation

Schneider Electric has selected CANopen for its machines and installations because of its wealth of functions and its resulting benefits in the automation world. This decision was based on the general acceptance of CANopen, and the fact that CANopen architectures are increasingly used in control system architectures. CANopen is an open network supported by more than 400 companies worldwide, and promoted by CAN in Automation (CiA).

CANopen conforms to standards EN 50325-4 and ISO 15745-2.

Schneider Electric is heavily involved in working groups, which are important for machine and installation architectures, systems and products.

- The bus uses a double shielded twisted pair on which, with Modicon M241 and Modicon M251 logic controllers, a maximum of 63 devices are connected by daisy-chaining or by tap junctions.
- Each end of the bus must be fitted with a line terminator. On M241 controllers, this line terminator is already integrated on the master side and can be disconnected using a switch located next to the CAN connector.

CANopen port on M241 and M251 controllers

| | | | | | | | | |
|-----------------------|---|---------------|----------------|----------------|-----------------|------------------|-----------------|------------------|
| Type | M241: screw terminals M251: 9-way SUB-D | | | | | | | |
| Standards | DS 301 V4.02, DR 303-1 | | | | | | | |
| Class | M10 | | | | | | | |
| Data rate | | | | | | | | |
| Max. length (m / ft.) | 20/ 65.62 | 40/ 131.23 | 100/ 328.08 | 250/ 820.21 | 500/ 1640.42 | 1000/ 3280.84 | 2500/ 8202.1 | 5000/ 16404.2 |
| Data rate (Kbps) | 1000 | 800 | 500 | 250 | 125 | 50 | 20 | 10 |
| Number of slaves | 63 slaves max. with limit of: 252 RPDOs and 252 TPDOs | | | | | | | |

Description

CANopen port on M241 and M251 controllers

The underside of Modicon **TM241CEC**... logic controllers has:

- 1 a connector for linking to the CANopen bus (screw terminals).
- 2 a CANopen line termination switch.

The front of the Modicon **TM251MES** logic controller has:

- 3 a connector for linking to the CANopen bus (9-way SUB-D).

CANopen connection architecture

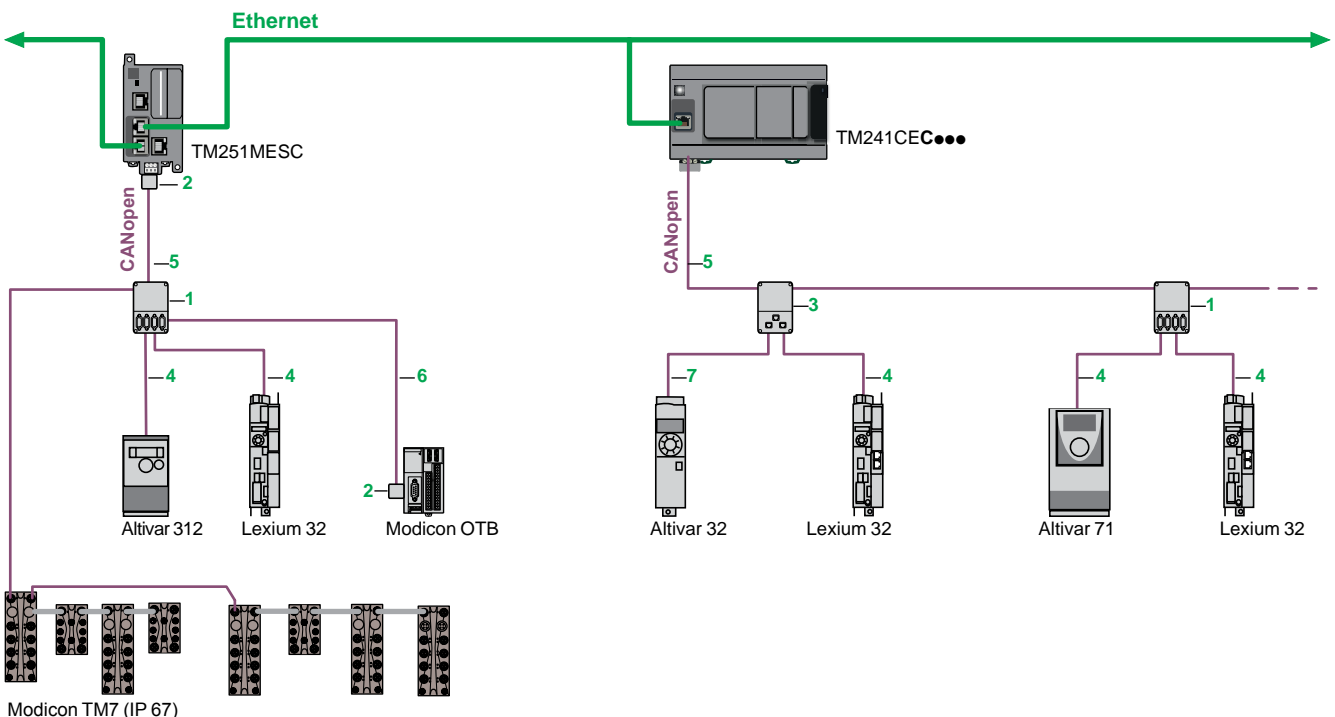

References

CANopen standard taps and connectors

| Designation | Description | Item | Lgth. mm / ft | Unit reference | Weight kg/lb |
|---|---|------|------------------|------------------------|-----------------|
| IP20 CANopen tap junction | Line termination : 4 SUB-D ports. Screw terminals for connecting the trunk cables | 1 | – | TSXCANTDM4 | 0.196/0.432 |
| IP 20 CANopen connectors 9-way female SUB-D Line end adapter switch | Right-angle | 2 | – | TSXCANKCDF90T | 0.046/0.101 |
| | Straight (for connection to the Altivar IMC integrated controller card) | 2 | – | TSXCANKCDF180T | 0.049/0.108 |
| | Right-angle with 9-way SUB-D for connecting a PC or diagnostic tool | 2 | – | TSXCANKCDF90TP | 0.051/0.112 |
| IP 20 CANopen tap junction for Altivar and Lexium 32 | 2 RJ45 ports | 3 | – | VW3CANTAP2 | 0.250/0.551 |
| Daisy chain taps | Equipped with: <input type="checkbox"/> 2 sets of spring terminals for daisy chain connection of the CANopen bus <input type="checkbox"/> 1 preassembled cordset with RJ45 connector for connecting the drive | – | 0.6 / 1.97 | TCSCNT026M16M | – |
| | Equipped with: <input type="checkbox"/> 2 RJ45 connectors for daisy chain connection of the CANopen bus <input type="checkbox"/> 1 preassembled cordset with RJ45 connector for connecting the drive | – | 0.3 / 0.98 | TCSCNT023F13M03 | – |
| CANopen line terminators | For RJ45 connector <i>Sold in lots of 2</i> | – | – | TCSCAR013M120 | – |
| | For screw terminal connector <i>Sold in lots of 2</i> | – | – | TCSCAR01NM120 | – |



TSXCANTDM4



VW3CANTAP2



TSXCANKCDF90T



TSXCANKCDF180T



TSXCANKCDF90TP



TCSCAR013M120



VW3CANA71

IP 20 standard cables and preassembled cordsets

| Designation | Description | Item | Lgth. mm/ft | Unit reference | Weight kg/lb | |
|---|---|--|----------------|---------------------|-------------------------|-------------|
| CANopen cables (2 x AWG 22 2 x AWG 24) | For standard environment (1), CE marking: Low smoke. Zero halogen. Non flame propagating (IEC 60332-1) | 5 | 50 / 164.042 | TSXCANCA50 | 4.930/10.869 | |
| | | | 100 / 328.08 | TSXCANCA100 | 8.800/19.401 | |
| | | | 300 / 984.25 | TSXCANCA300 | 24.560/54.146 | |
| | For standard environment (1), UL certification, CE marking: Flame-retardant (IEC 60332-2) | 5 | 50 / 164.04 | TSXCANCB50 | 3.580/7.893 | |
| | | | 100 / 328.08 | TSXCANCB100 | 7.840/17.284 | |
| | | | 300 / 984.25 | TSXCANCB300 | 21.870/48.215 | |
| | For harsh environment (1) or mobile installation, CE marking: Low smoke. Zero halogen. Non flame propagating (IEC 60332-1). Oil-resistant | 5 | 50 / 164.04 | TSXCANCD50 | 3.510/7.738 | |
| | | | 100 / 328.08 | TSXCANCD100 | 7.770/17.130 | |
| | | | 300 / 984.25 | TSXCANCD300 | 21.700/47.840 | |
| CANopen preassembled cordsets | Cordsets with one 9-way female SUB-D connector at each end | For standard environment (1), CE marking: Low smoke. Zero halogen. Non flame propagating (IEC 60332-1) | 6 | 0.3 / 0.98 | TSXCANCADD03 | 0.091/0.201 |
| | | | | 1 / 3.28 | TSXCANCADD1 | 0.143/0.315 |
| | | | | 3 / 9.84 | TSXCANCADD3 | 0.295/0.650 |
| | | | | 5 / 16.40 | TSXCANCADD5 | 0.440/0.970 |
| | | For standard environment (1), UL certification, CE marking: Flame-retardant (IEC 60332-2) | 6 | 0.3 / 0.98 | TSXCANCBDD03 | 0.086/0.190 |
| | | | | 1 / 3.28 | TSXCANCBDD1 | 0.131/0.289 |
| | | | | 3 / 9.84 | TSXCANCBDD3 | 0.268/0.591 |
| | | | | 5 / 16.40 | TSXCANCBDD5 | 0.400/0.882 |
| | Cordsets with one 9-way female SUB-D connector and one RJ45 connector | | 4 | 0.5 / 1.64 | TCSCCN4F3M05T | 0.100/0.220 |
| | | | | 1 / 3.28 | TCSCCN4F3M1T | 0.100/0.220 |
| | | | | 3 / 9.843 | VW3M3805R010 (2) | 0.100/0.220 |
| | | | | 1 / 3.281 | VW3M3805R030 (2) | 0.300/0.661 |
| | | | 3 / 9.84 | TCSCCN4F3M3T | 0.160/0.353 | |
| | | | 0.5 / 1.64 | TLACDCBA005 | 0.100/0.220 | |
| | | | 1.5 / 4.92 | TLACDCBA015 | 0.120/0.265 | |
| | | | 3 / 9.84 | TLACDCBA030 | 0.190/0.419 | |
| Cordsets with two 9-way SUB-D connectors, one male and one female | | | 5 / 16.40 | TLACDCBA050 | 0.350/0.772 | |
| | | 7 | 0.3 / 0.984 | VW3CANCARR03 | 0.100/0.220 | |
| | | | 1 / 3.281 | VW3CANCARR1 | 0.100/0.220 | |
| Adapter for Altivar 71 drive | One RJ45 connector at each end | – | – | VW3CANA71 | 0.100/0.220 | |

Taps and IP 67 accessories

Please consult the **Modicon TM7** offer: interface blocks (IP 67) for distributed I/O on the CANopen bus [See page 4/32](#)

(1) Standard environment: no particular environmental constraints, operating temperature between + 5°C and + 60°C (+ 41°F and + 140°F), and in fixed installations.

Harsh environment: resistance to hydrocarbons, industrial oils, detergents, solder splashes, relative humidity up to 100%, saline atmosphere, significant temperature variations, operating temperature between - 10°C and + 70°C (+ 14°F and + 158°F), or in mobile installations.

(2) Cordset equipped with a line terminator.

Communication

CANopen Optimized Architecture with Modicon OTB

for Magelis XBTGC HMI controllers, XBTGT/GK with control function, Altivar IMC drive controller



Presentation

Schneider Electric has selected the CANopen bus for its machines and installations because of its wealth of functions and its resulting benefits in the automation world. This decision was based on the general acceptance of CANopen by the automation engineer community due to its openness and universality, and the fact that CANopen products are increasingly used in control system architectures.

CANopen is an open communication bus supported by more than 400 companies worldwide, and promoted by CAN in Automation (CIA) <http://www.can-cia.org/>. CANopen conforms to standards EN 50325-4 and ISO 15745-2.

CANopen brings transparency to Ethernet

The CANopen bus is a multi-master bus affording reliable, deterministic access to real-time data in control system equipment. The CSMA/CA protocol is based on broadcast exchanges, sent cyclically or on an event, to ensure optimum use of the bandwidth. A message handling channel can also be used to define slave parameters.

The bus uses a double shielded twisted pair on which, with the Magelis XBTGC HMI controllers, XBTGT/GK with control function and Altivar IMC drive controller, a maximum of 16 slave devices are connected by daisy-chaining or by tap junctions. The variable data rate between 20 kbps and 1 Mbps depends on the length of the bus: between 20 m and 1000 m (between 65.617 ft and 3280.840 ft). Recommendation: equip each end of the bus with a line terminator.

The CANopen bus is a set of profiles on CAN systems, possessing the following characteristics:

- Open bus system
- Data exchanges in real time without overloading the protocol
- Modular design allowing modification of size
- Interconnection and interchangeability of devices
- Standardized network configuration
- Access to device parameters
- Synchronization and circulation of data from cyclic and/or event-controlled processes (short system response time)

Connectable Schneider Electric devices

The following Schneider Electric devices can be connected to the CANopen bus:

- Ø 58 mm (2.283 in.) OsiSense XCC multi-turn absolute encoders: **XCC3510P/3515CS84CB**.
- TeSys U starter-controllers with communication module **LULC08**.
- TeSys T motor management system with controller **LTMR●●C●●**.
- Modicon OTB IP 20 distributed I/O with I/O expansion modules with interface module **OTB1C0DM9LP**.
- Preventa configurable safety controllers **XPSMC16ZC/MC32ZC**.
- Altivar 61/71 variable speed drives for asynchronous motors (0,75...630 kW/1...844.5 hp) **ATV61/71H●●●●**.
- Altivar 32 variable speed drives for asynchronous motors (0.18...15 kW/0,241...20.1 hp) **ATV32H●●●●**.
- Lexium 32 servo drives (0.15...7 kW/ 0.201...9.38 hp) for BSH/BSM servo motors **LXM32A●D●●●●**.
- Lexium integrated drives **ILA1B, ILE1B and ILS1B**.

4



TeSys U with communication module LULC08



Modicon OTB



Preventa XPS MC



Altivar 71



Altivar 32



LEX32A



Lexium ILA1B

Communication

CANopen bus

Integrated CANopen bus port

Altivar IMC drive controller for ATV61/71 variable speed drives

Tested Validated and Documented Architecture

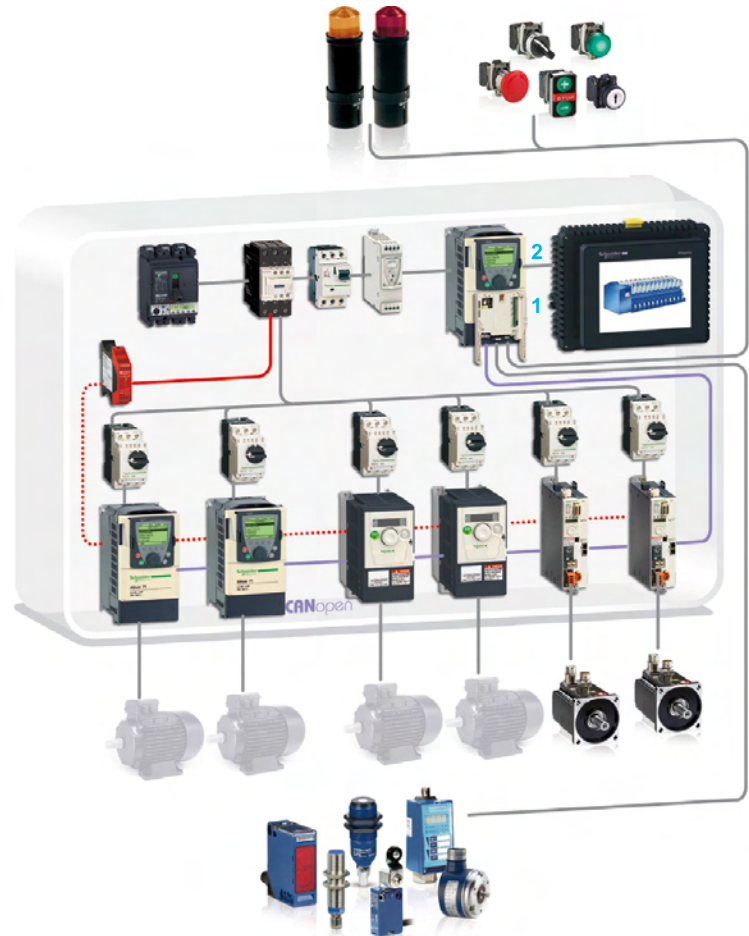

- 1 Altivar IMC card
- 2 Altivar 61/71 variable speed drive

Altivar IMC integrated controller card CANopen port

The Altivar IMC integrated controller card has a built-in 9-way male SUB-D CANopen port and acts as the CANopen master.

The bus consists of a master station, the Altivar IMC card, and slave stations. The master is in charge of configuration, exchanges and diagnostics to the slaves.

The CANopen bus is used to manage a variety of slaves such as:

- Discrete slaves
- Analog slaves
- Variable speed drives
- Motor starters
- Etc.

| CANopen port | | | | | | | |
|------------------|------------------|---|-----|-----|-----|------|------|
| Standards | | DS 301 V4.02, DR 303-1 | | | | | |
| Class | | Conformity class M20, limited to 16 slaves | | | | | |
| Data rate | Max. length (m) | 20 | 100 | 250 | 500 | 1000 | 2500 |
| | Data rate (kbps) | 1000 | 500 | 250 | 125 | 50 | 20 |
| Number of slaves | | 16 max. with max. limit of: 32 RPDOs and 32 TPDOs | | | | | |
| Connection | | On 9-way male SUB-D port | | | | | |

CANopen Optimized architecture

Wiring system, see page 4/24.

Communication

CANopen bus

CANopen bus master module

Magelis XBTGC HMI controllers, XBTGT/GK with control function

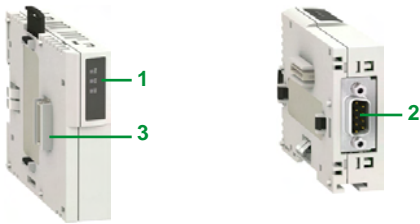

XBTZGCCAN

Description

The **XBTZGCCAN** CANopen bus master module consists of:

- 1 3 LEDs (PWR, RUN, ERR) providing details of the power supply status and module operation
- 2 A 9-way male SUB-D connector for connecting to the CANopen bus
- 3 A connector for connecting to the XBTGC HMI Controller

Reference

| Description | Reference | Weight kg/ lb |
|--|------------------|---------------------|
| CANopen bus master module for Magelis XBTGC HMI Controller. Conformity class M10 | XBTZGCCAN | 0.100/ 0.220 |

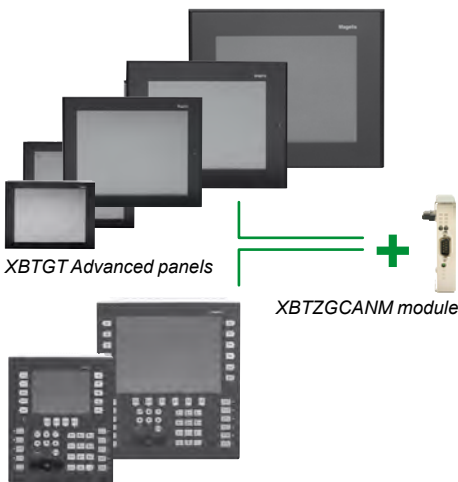

Advanced panels XBTGK

HMI function: Magelis XBTGT/GK Advanced Panels

+
Control function: XBTZGCANM CANopen master module

Description

The **XBTZGCANM** CANopen bus master module consists of:

- 1 3 LEDs (PWR, RUN, ERR) providing details of the power supply status and module operation
- 2 A 9-way male SUB-D connector for connecting to the CANopen bus
- 3 A connector for connecting to the rear of the Magelis XBTGT/GK Advanced Panels
- 4 Positions for fixing screws

Reference

| Description | Reference | Weight kg/ lb |
|---|------------------|---------------------|
| CANopen bus master module for Magelis XBTGT/GK Advanced Panels Conformity class M10 | XBTZGCANM | 0.100/ 0.220 |

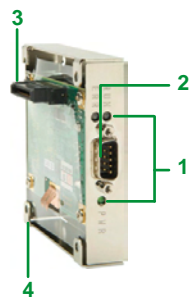

XBTZGCANM

Communication

Distributed I/O on CANopen bus with Modicon OTB (IP 20)

For Magelis XBTGC HMI controllers, XBTGT/GK with control function, Altivar IMC drive controller



OTB1C0DM9LP
CANopen bus interface module

Presentation

The Modicon OTB offer proposes fewer references relating to spare parts and accessories that are required for creating an island.

The Modicon OTB offer has also been designed to be as simple as possible. This offer, compatible with Magelis XBTGC HMI controllers, XBTGT/GK with control function and Altivar IMC drive controller, includes 2 communication bases (interface modules) for the various types of fieldbus:

- CANopen bus,
- Modbus RS 485 Serial Line.

Inputs and outputs are directly integrated in the interface modules. Each base incorporates 20 I/O:

- 12 \pm 24 V inputs,
- 6 relay outputs,
- 2 \pm 24 V solid-state outputs.

With its range of I/O expansions, the Modicon OTB offer provides a wide modularity: a base can be fitted with up to 7 digital I/O modules **TM2 D●●** or analogue I/O modules **TM2 A●●**. The expansion modules, like the interface modules, simply clip-on to 35 mm (1.378 in.) symmetrical rail and enable configurations of up to 244 digital I/O and up to 42 analogue I/O channels, or a mixture of both types (within the limit of 7 expansion modules), to be obtained.

Sensors and actuators are connected to the interface modules and I/O expansion modules using removable screw terminal blocks.

The Modicon OTB module range provide an IP 20 degree of protection.

To simplify sensor and actuator connections, as well as linking commons, the Modicon OTB offer also includes a commoning module **OTB9ZZ61JP**. This module, as the other modules of the Modicon OTB range, allows the through connection of the internal bus or network (passively in this case) and enables connection of the commons in two isolated groups for each commoning module.

Configuration of interface modules

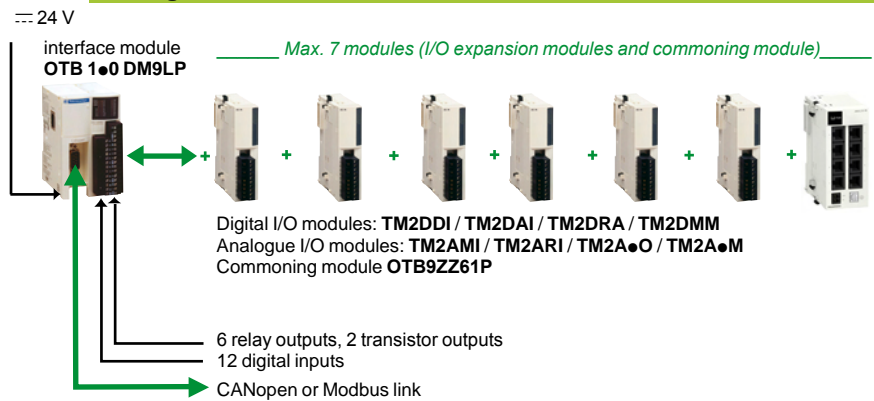

4

Communication

Distributed I/O on CANopen bus with Modicon OTB (IP 20)

For Magelis XBTGC HMI controllers, XBTGT/GK with control function, Altivar IMC drive controller

Description

The Modicon **OTB1●0 DM9LP** (1) interface modules comprise:

- 1 An access door.
- 2 Indicator lights:
 - module and communication status (PWR, RUN, ERR, COM, STAT)
 - I/O states (IN● and OUT●)
- 3 A connector for expansion modules (right-hand side).
- 4 Two removable screw terminal connectors for connection of inputs/outputs.
- 5 or 6 Depends on model:
 - 5 A SUB-D 15-way connector for connection CANopen bus with **OTB1C0DM9LP** model.
 - 6 Two RJ45 connectors for connection Modbus serial link with **OTB1S0DM9LP** model.
- 7 Terminal for connection of \pm 24 V supply.
- 8 One RJ45 connector for operating system update of interface.

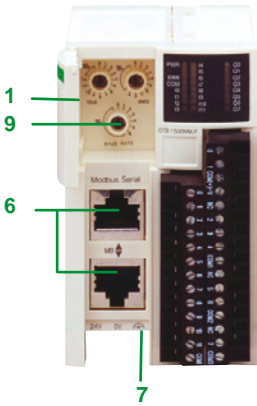
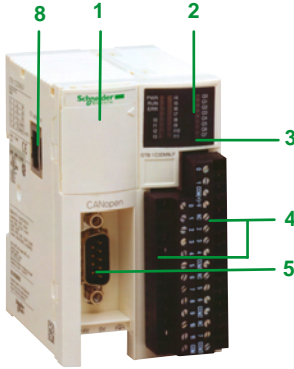

Via access door 1

- 9 Two or three coding wheels (depending on model) for OTB island address and communication data rate adjustment.

Mounting: the interface modules is mounted on 35 mm (1.378 in.) symmetrical \perp rail. Mounting kit **TWDXMT5** (supplied in lots of 5) allows plate or panel mounting.



OTB1C0DM9LP



OTB1S0DM9LP



OTB9ZZ61JP

Interface modules with integrated digital I/O

| Supply voltage | Number and type of integrated I/O | | | Connection by Link | Reference | Weight kg/ lb |
|----------------|---------------------------------------|---------------------------|---|--------------------------------|--|------------------------------------|
| | Inputs | Solid-state outputs | Relay outputs | | | |
| \pm 24 V | 12 I \pm 24 V IEC type 1 (1 common) | 2 O \pm 24 V (1 common) | 6 O \pm 30 V / \sim 240 V 2 A (3 commons) | Removable screw terminal block | CANopen bus Modbus RS 485 serial link | 0.195/ 0.430 0.190/ 0.430 |

Separate parts

| Description | Application | Number of commons | Connection by | Number of wires | Reference | Weight kg/ lb |
|---|--|-------------------|--------------------------------|-----------------|-------------------|---------------------|
| Commoning modules | For grouping input or output commons, 8 A maximum; inter-module | 2 isolated groups | Removable screw terminal block | 2 x 10 | OTB9ZZ61JP | 0.100/ 0.220 |
| Mounting kit Sold in lot of 5 | Plate or panel mounting of modules | – | – | – | TWDXMT5 | – |
| Software and documentation | Configuration software "Modicon Configuration Tool-Lite" and hardware user guide | – | – | – | FTXES01 | 0.050/ 1.102 |

Connection accessories

| Description | Application | Reference |
|---------------------------|---|--|
| CANopen bus | Cabling system: junction boxes, cables, cordsets, IP 20 and IP 67 accessories | See page 4/20 |
| Modbus serial link | Cabling system: tap-off, hub, cables, cordsets, line end adapter | please refer to our website www.schneider-electric.com |

(1) Only the communication part 5, 6 and 9 is dedicated to each model and can differ, the general description remains the same.

CANopen Optimized architecture

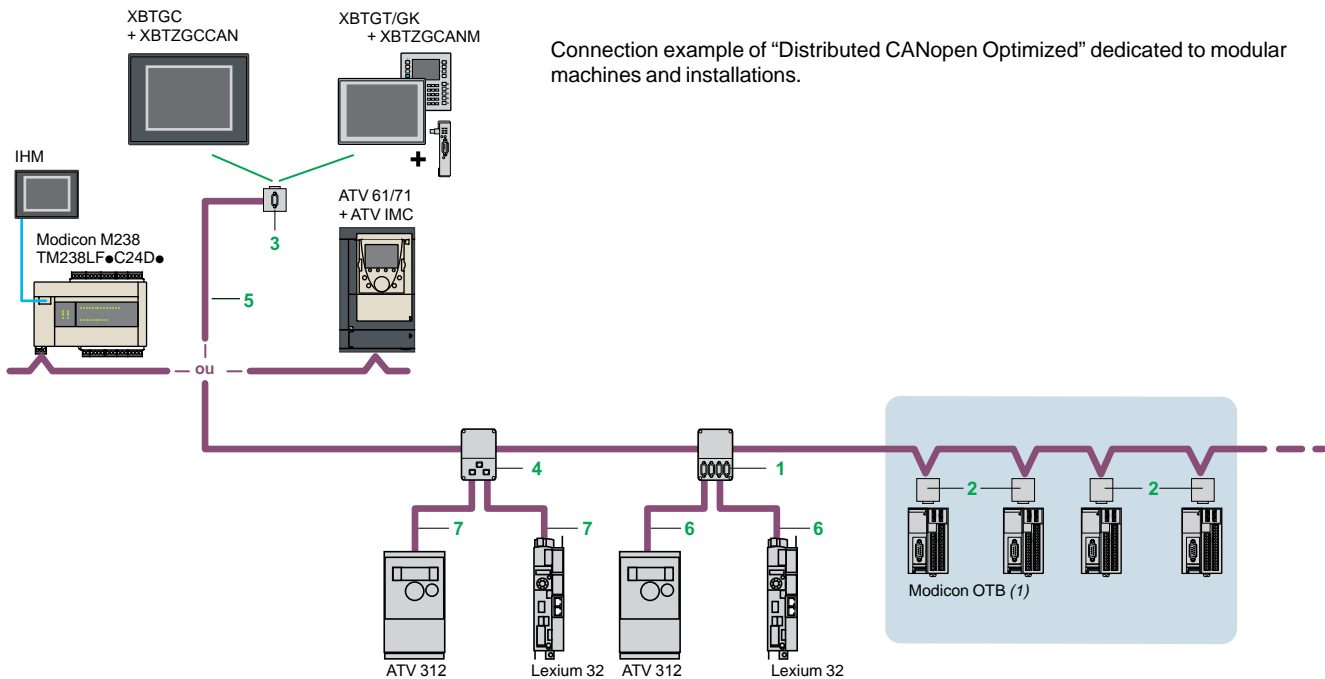

4

Références



TSXCANTDM4



VW3CANTAP2



TSXCANKCD F90T



TSXCANKCD F180T



TSXCANKCD F90TP



TCSCAR013M120

Standard junction boxes and connectors

| Description | Composition | Item | Length m/ft | Unit reference | Weight kg/lb |
|---|--|------|-------------|-----------------|-----------------|
| CANopen IP 20 tap junction box | 4 SUB-D ports. Screw terminal blocks for connection of main cables Line end adapter | 1 | – | TSXCANTDM4 | 0.196/ 0.432 |
| IP 20 connectors CANopen 9-way SUB-D female. Line end adapter switch | Elbowed (90°) | 2 | – | TSXCANKCDF90T | 0.046/ 0.101 |
| | Straight (2) | – | – | TSXCANKCDF180T | 0.049/ 0.108 |
| | Elbowed (90°) with 9-way SUB-D connector for connection to PC or diagnostic tool | 3 | – | TSXCANKCDF90TP | 0.051/ 0.112 |
| M12 connectors IP 67 | Male | – | – | FTXCN12M5 | 0.050/ 0.110 |
| | Female | – | – | FTXCN12F5 | 0.050/ 0.110 |
| CANopen IP 20 tap junction box for Altivar and Lexium 05 | 2 x RJ45 ports | 4 | – | VW3CANTAP2 | 0.250/ 0.551 |
| Daisy chain taps | Equipped with: - 2 spring terminal blocks for connecting the CANopen bus in a daisy chain - 1 preassembled cordset with an RJ45 connector for connecting the drive | – | 0.6/1.97 | TCSCTN026M16M | – |
| | Equipped with: - 2 RJ45 connectors for connecting the CANopen bus in a daisy chain - 1 preassembled cordset with an RJ45 connector for connecting the drive | – | 0.3/0.98 | TCSCTN023F13M03 | – |
| CANopen line terminators | For RJ45 connector <i>Sold in packs of 2</i> | – | – | TCSCAR013M120 | – |
| | For screw terminal connector <i>Sold in packs of 2</i> | – | – | TCSCAR01NM120 | – |

(1) Modicon OTB product range. See page 4/18.

(2) For connection to an integrated controller card Altivar IMC.

References (continued)

| Standard IP 20 formed cables | | | | | |
|---|---|--------------------|--|--|----------------------|
| Description | Application | Item | Length m/ft | Unit reference | Weight kg/ lb |
| CANopen cables (2 x AWG 22 2 x AWG 24) | For standard environments (2), CE marking: low fume emission. Halogen-free. Non flame propagating (IEC 60332-1) | 5 | 50/ 164.04 | TSXCANCA50 | 4.930/ 10.869 |
| | | | 100/ 328.08 | TSXCANCA100 | 8.800/ 19.401 |
| | | | 300/ 984.25 | TSXCANCA300 | 24.560/ 54.146 |
| | For standard environments (2), UL certified, CE marking: non flame propagating (IEC 60332-2) | 5 | 50/ 164.04 | TSXCANCB50 | 3.580/ 7.893 |
| | | | 100/ 328.08 | TSXCANCB100 | 7.840/ 17.284 |
| | | | 300/ 984.25 | TSXCANCB300 | 21.870/ 48.215 |
| | For standard environments (2) or mobile installation, CE marking: low fume emission. Halogen-free. Non flame propagating (IEC 60332-1). Oil resistant | 5 | 50/ 164.04 | TSXCANCD50 | 3.510/ 7.738 |
| | | | 100/ 328.08 | TSXCANCD100 | 7.770/ 17.130 |
| | | | 300/ 984.25 | TSXCANCD300 | 21.700/ 47.840 |
| CANopen formed cables 1 x 9-way SUB-D female connector at each end. | For standard environments (2), CE marking: low fume emission. Halogen-free. Non flame propagating (IEC 60332-1) | - | 0.3/ 0.98 | TSXCANCADD03 | 0.091/ 0.201 |
| | | | 1/ 3.28 | TSXCANCADD1 | 0.143/ 0.315 |
| | | | 3/ 9.84 | TSXCANCADD3 | 0.295/ 0.650 |
| | | | 5/ 16.40 | TSXCANCADD5 | 0.440/ 0.970 |
| | | | For standard environments (2), UL certified, CE marking: non flame propagating (IEC 60332-2) | - | 0.3/ 0.98 |
| | 1/ 3.28 | TSXCANCBDD1 | 0.131/ 0.289 | | |
| | 3/ 9.84 | TSXCANCBDD3 | 0.268/ 0.591 | | |
| | 5/ 16.40 | TSXCANCBDD5 | 0.400/ 0.882 | | |
| | CANopen formed cables Formed cables with 1 x 9-way SUB-D female connector and 1 x RJ45 connector | 6 | 0.5/ 1.64 | | TCSCCN4F3M05T |
| | | | 1/ 3.28 | TCSCCN4F3M1T | 0.100/ 0.220 |
| | | | 3/ 9.84 | VW3M3805R010(2) | 0.100/ 0.220 |
| | | | 1/ 3.28 | VW3M3805R030(2) | 0.300/ 0.661 |
| | | | 3/ 9.84 | TCSCCN4F3M3T | 0.160/ 0.353 |
| | Formed cables with 2 x 9-way SUB-D connectors, 1 female and 1 male | - | 0.5/ 1.64 | TLACDCBA005 | 0.100/ 0.220 |
| | | | 1.5/ 4.92 | TLACDCBA015 | 0.120/ 0.265 |
| 3/ 9.84 | | | TLACDCBA030 | 0.190/ 0.419 | |
| 5/ 16.40 | | | TLACDCBA050 | 0.350/ 0.772 | |
| IP 20 connection accessories | | | | | |
| CANopen connector for Altivar 71 (3) | 9-way SUB-D female. Line end adapter switch. 180° cable entry | - | - | VW3CANKCDF180T | 0.100/ 0.220 |
| Adapter for Altivar 71 variable speed controller | CANopen SUB-D to RJ45 adapter | - | - | VW3CANA71 | 0.100/ 0.220 |
| Formed CANopen cables | 1 RJ45 connector at each end. | 7 | 0.3/ 0.98 | VW3CANCARR03 | 0.100/ 0.220 |
| | | | 1/ 3.28 | VW3CANCARR1 | 0.100/ 0.220 |
| | | | CANopen bus adapter for Lexium 17D | Hardware interface for link conforming to the CANopen standard + 1 connector for connection of PC terminal | - |
| Y connector | CANopen/Modbus | - | - | TCSCTN011M11F | 0.100/ 0.220 |



VW3CANA71



AM02CA001V000



FTXDP21●●

(1) Standard environment: without any particular environmental restrictions, operating temperature between + 5 °C and + 60 °C, (+ 41 °F and + 140 °F) and for fixed installation. Harsh environments: resistant to hydrocarbons, industrial oils, detergents, solder splashes, hygrometry up to 100%, saline environment, wide temperature variations, operating temperature between - 10 °C and + 70 °C (+ 14 °F and + 158 °F), or mobile installation.

(2) Cable equipped with line end adapter.

(3) For variable speed controllers **ATV71H●●●M3**, **ATV71HD11M3X**, **HD15M3X**, **ATV71H075N4... HD18N4**, this connector can be replaced by connector **TSXCANKCDF180T**.



Presentation

Schneider Electric has selected CANopen for its machines and installations because of its wealth of functions and its resulting benefits in the automation world. This decision was based on the general acceptance of CANopen, and the fact that CANopen products are increasingly used in control system architectures. CANopen is an open network supported by more than 400 companies worldwide, and promoted by CAN in Automation (CiA). CANopen conforms to standards EN 50325-4 and ISO 15745-2.

CANmotion and CANopen characteristics

CANmotion and CANopen buses are multi-master buses ensuring reliable, deterministic access to real-time data in control system equipment. The CSMA/CA protocol is based on broadcast exchanges, sent cyclically or on an event, to ensure optimum use of the bandwidth.

A message handling channel can also be used to define slave parameters.

CANmotion and CANopen buses are a set of profiles on CAN systems with the following characteristics:

- Open bus system
- Data exchanges in real time without overloading the protocol
- Modular design allowing modification of size
- Interconnection and interchangeability of devices
- Standardized network configuration
- Access to all device parameters
- Synchronization and circulation of cyclical and/or event-controlled process data (short system response time)

Connectable Schneider Electric devices

The following Schneider Electric devices can be connected to the CANopen bus:

- Ø 58 mm OsiSense XCC multi-turn absolute encoders: **XCC3510P**, **XCC3515CS84CB**
- TeSys U starter-controllers with communication module: **LULC08**
- TeSys T motor management system with controller: **LTMR●●C●●**
- Modicon **TM5** Transmitter/Receiver modules (IP 20)
- Modicon **TM7** I/CANopen interface blocks (IP 67)
- Preventa safety configurable controllers **XPSMC16ZC**, **XPSMC32ZC**.
- Altivar 61/71 variable speed drives for asynchronous motors (0.75...630 kW): **ATV61H/71H ●●●●●**
- Altivar 32 variable speed drives for asynchronous motors (0,18...15Kw): **ATV32H●●●●**
- Lexium 32 servo drives (0.15...7 kW) for BSH/BSM servo motors: **LXM32A●D●●●●**
- Lexium **SD3** stepper drives
- Lexium integrated drives: **ILA1B**, **ILE1B** and **ILS1B**

CANopen Performance architecture

Wiring system, see page 4/38.

4



TeSys U + communication module LUL C08



Modicon TM5 Transmitter/Receiver module



Modicon TM7 CANopen interface Blocks



Preventa XPSMC



Altivar 71



Altivar 32



LEX32A



Lexium ILA1B

Communication

CANopen bus

Integrated CANopen bus

for Modicon M258 logic controller, Modicon LMC058 motion controller

Tested Validated Documented Architectures

Modicon M258 logic controller

Modicon LMC058 motion controller

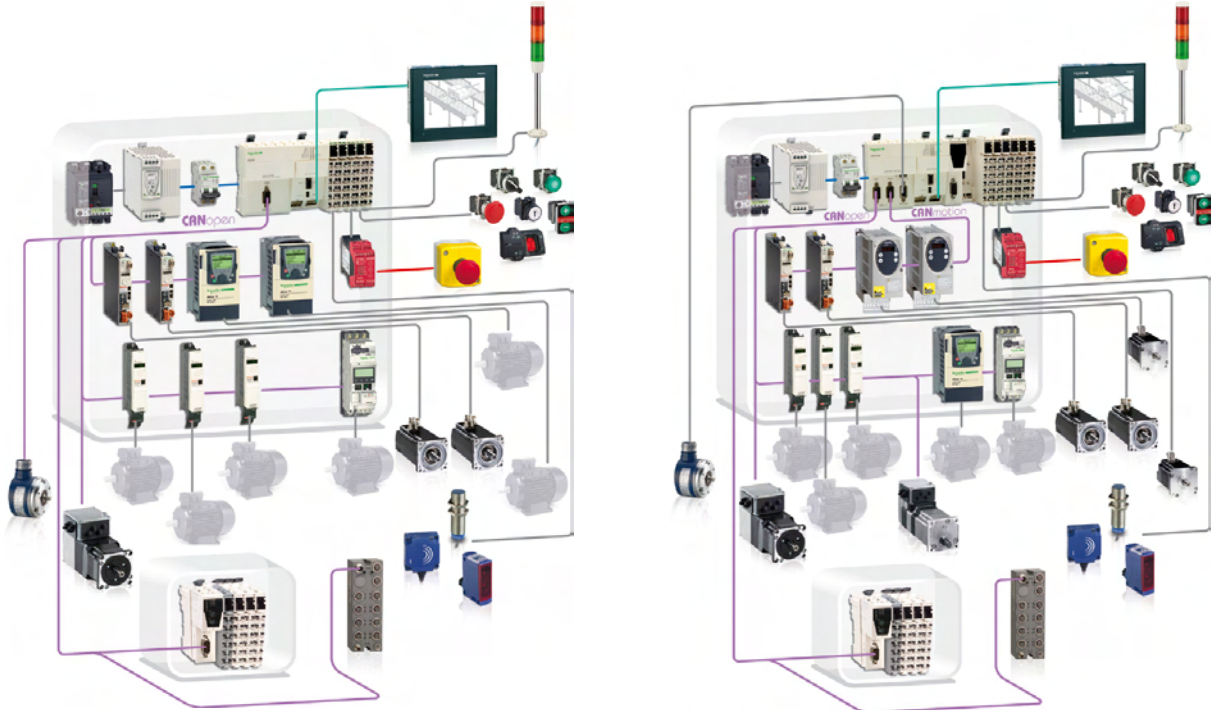

4

CANopen port on M258 logic controller and LMC058 motion controller

Modicon M258 logic controllers (referenced **TM258LF●●●●**) and all LMC058 motion controllers include a 9-way male SUB-D CANopen port and act as the CANopen master.

The bus consists of a master station, M258 logic controller or LMC058 motion controller and slave stations. The master is in charge of configuration, exchanges and diagnostics to the slaves.

The CANopen bus is a communication bus and is used to manage a variety of slaves, such as:

- Digital slaves
- Analog slaves
- Variable speed drives
- Motor starters
- Etc.

CANopen port

| | | | | | | | | | |
|------------------|---|------|-----|-----|-----|-----|------|------|------|
| Standards | DS 301 V4.02, DR 303-1 | | | | | | | | |
| Class | Conformity class M10, limited to 63 slaves | | | | | | | | |
| Data rate | Max. length (m) | 20 | 40 | 100 | 250 | 500 | 1000 | 2500 | 5000 |
| | Data rate (kbps) | 1000 | 800 | 500 | 250 | 125 | 50 | 20 | 10 |
| Number of slaves | 63 max. with max. limit of: 64 TDPOs/64 RPDOs | | | | | | | | |
| Connection | On 9-way male SUB-D port | | | | | | | | |

CANmotion port on LMC058 motion controllers

LMC058 motion controllers include a 9-way male SUB-D CANmotion port and act as the CANmotion master.

This CANmotion connection offers the option of configuring and controlling up to 8 Lexium 32 drives and/or Lexium SD3 stepper drives.

The CANmotion bus cycle time ensures that the axis positions will be refreshed.

Communication

Modicon TM5 (IP 20) interface module for distributed I/O on CANopen bus for Modicon M258 logic controller, Modicon LMC058 and Modicon LMC078 motion controllers

Presentation

To enhance its "Flexible machine Control" concept, a key component of MachineStruxure™, the Modicon M258 logic controller, Modicon LMC058 and Modicon LMC078 motion controller offers, Schneider Electric offers a Modicon TM5 CANopen interface module providing CANopen access to distributed I/O.

- M258 logic controller, Modicon LMC058 and Modicon LMC078 motion controllers offer the possibility of creating distributed I/O islands via the TM5 expansion bus, which enables the architecture to be adapted to match the topology of the machine as closely as possible and reduces wiring costs.
- The Modicon TM5 CANopen interface module allows the connection of distributed I/O islands (sensors and actuators) that are distributed over machines via the CANopen fieldbus. These islands communicate on the CANopen bus.

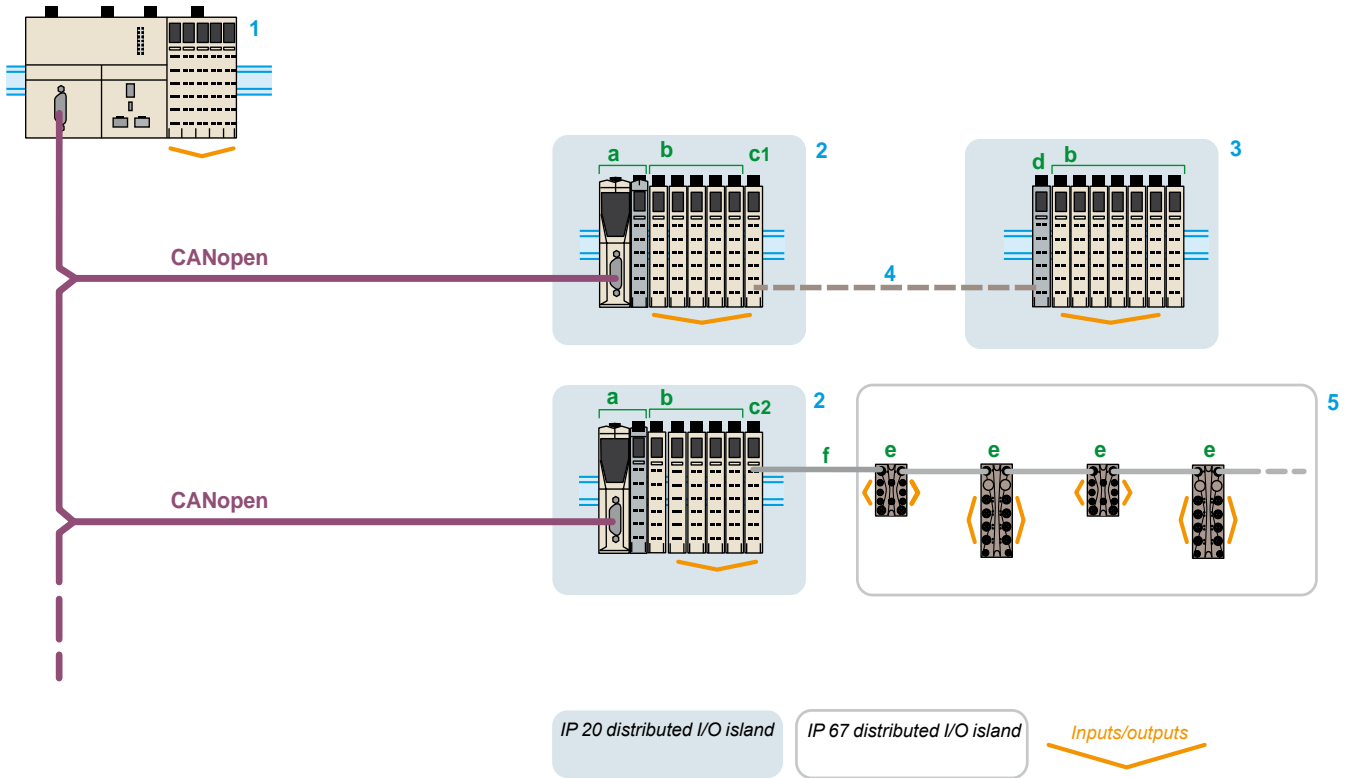

- 1 Modicon M258 logic controller, Modicon LMC058 or Modicon LMC078 motion controllers: CANopen bus masters.
- 2 IP 20 distributed I/O islands (1). Composition: TM5 CANopen interface module (slave) (a) + TM5 compact block or I/O modules (b) + transmitter modules TM5SBET1 (c1)/TM5SBET7 (c2).
- 3 IP 20 distributed I/O island (1). Composition: receiver module TM5SBER2 (d) + TM5 compact block or TM5 I/O modules (b).
- 4 TM5 expansion bus (1). Composition: remote I/O connection cable TCSXCNNXN100.
- 5 IP 67 distributed I/O island (2). Composition: TM7 IP67 I/O blocks (digital or analog) (e) + expansion bus cable TM7TCSXCN●●●E (f).

(1) Modicon TM5 extension modules: see page 3/38.

(2) Modicon TM7 I/O blocks and TM7 expansion bus cables: see page 3/64.

Communication

Modicon TM5 (IP 20) interface module for distributed I/O on CANopen bus for Modicon M258 logic controller, Modicon LMC058 and Modicon LMC078 motion controllers



Presentation

The TM5 CANopen interface module offer consists of 4 parts to be ordered separately (1):

- A bus base, TM5ACBN1 (2)
- A CANopen electronic interface module, TM5NCO1
- A power distribution electronic module, TM5SPS3
- A removable terminal block, TM5ACTB12PS

The modules can be mechanically assembled on the bus base before mounting on a symmetrical rail.

These modules offer the following advantages:

- Removable terminal block
- Spring terminals for connecting the power supply of the interface module and the I/O expansion modules quickly, with no tools required. In addition, the quality of the spring terminals avoids the need for periodic retightening

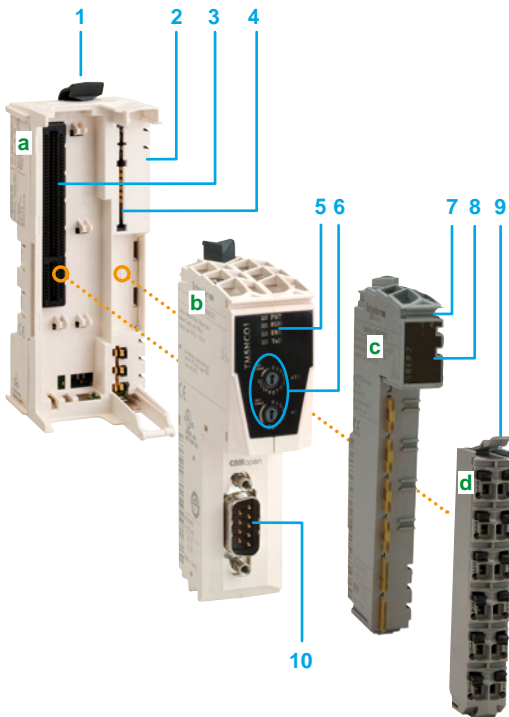

Description

The CANopen interface module is a combination of 4 products: A TM5ACBN1 bus base (a) + a TM5NCO1 CANopen electronic interface module (b) + a TM5SPS3 power distribution electronic module (c) (1) + a TM5ACTB12PS removable terminal block (d).

This assembly comprises:

- 1 A mechanical locking lever for mounting/dismounting on a symmetrical rail
- 2 On the side of the base, an expansion bus connection for the link with the next module
- 3 A slot for the CANopen interface module with connector
- 4 A slot for the power distribution module with connector
- 5 A channel and interface module diagnostics LED display block
- 6 Two rotary selector switches for addresses on the bus
- 7 A slot for labelling (label-holder)
- 8 A channel and power distribution module diagnostics LED display block
- 9 A removable spring terminal block with locking clip and slots for coloured identifiers
- 10 A 9-way male SUB-D connector for connecting to the CANopen bus

(1) Also sold in kit, see page 4/27.

(2) Supplied with 2 protective plates, TM5ACPL10 and TM5ACPR10.

Communication

Modicon TM5 (IP 20) interface module for distributed I/O on CANopen bus for Modicon M258 logic controller, Modicon LMC058 and Modicon LMC078 motion controllers

Specifications

| | | |
|--|----------------------|---|
| Conformity with standards | | IEC 61131-2 |
| Product certifications | | CE, UL, CSA, GOST-R and c-Tick |
| Temperature | Operation | Horizontal mounting: - 10...+ 60°C (1) Vertical mounting: - 10...+ 50°C |
| | Storage | - 40...+ 70°C |
| Relative humidity | | 95% max. without condensation |
| Degree of protection | | IP 20 conforming to IEC 61131-2 |
| Degree of pollution | | ≤ 2 conforming to IEC 60664 |
| Altitude | Operation | 0...2000 m |
| | Storage | 0...3000 m |
| Vibration resistance (mounting on rail) | | 5...8.4 Hz (3.5 mm fixed amplitude) 8.4...150 Hz (9.8 m/s ² fixed acceleration) |
| Shock resistance | | 147 m/s ² (15 gn) for 11 ms |
| Connector | Type | Removable spring terminals |
| | Number of operations | 50 min. |

Electromagnetic compatibility

| | | |
|--|--|---|
| Electrostatic discharges conforming to EN/IEC 61000-4-2 | | 8 kV: air discharge 4 kV: direct contact |
| Electromagnetic fields conforming to EN/IEC 61000-4-3 | | 10 V/m (80 MHz...2 GHz) 1 V/m (2...2.7 GHz) |
| Fast transients conforming to EN/IEC 61000-4-4 | | Supply: 2 kV I/O: 1 kV Shielded cable: 1 kV (repetition frequency 5 and 100 kHz) |
| Immunity to overvoltages, 24 V$\overline{---}$ circuit conforming to EN/IEC 61000-4-5 | | 1 kV in common mode |
| | | 0.5 kV in differential mode |
| Induced magnetic fields conforming to EN/IEC 61000-4-6 | | 10 Vrms (0.15...80 MHz) |
| Conducted emissions conforming to EN/IEC 55011/CISPR11 | | 150...500 kHz, quasi-peak at 79 dB μ V |
| | | 500 kHz...30 MHz, quasi-peak at 73 dB μ V |
| Radiated emissions conforming to EN/IEC 55011/CISPR11 | | 30...230 MHz, 10 m @ 40 dB μ V/m |
| | | 230 MHz...1 GHz, 10 m @ 47 dB μ V/m |

(1) Some devices have an operating temperature which requires a weighting factor between 55° and 60°C and may be subject to other restrictions. Refer to the user guide, which can be downloaded from www.schneider-electric.com

Communication

Modicon TM5 (IP 20) interface module for distributed I/O on CANopen bus for Modicon M258 logic controller, Modicon LMC058 and Modicon LMC078 motion controllers



TM5NCO1



TM5SPS3



TM5ACBN1



TM5ACTB12PS



TM5ACTLC100



TM5ACTCH100



TM5ACLPL10



TM5ACLPR10



TM5NCO1K

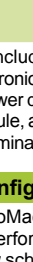
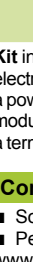

References

CANopen electronic interface module

| Description | Characteristics | Reference | Weight kg/lb |
|-------------------------------------|--|-----------|-----------------|
| CANopen electronic interface module | CAN bus communication module with CANopen protocol Module colour: white | TM5NCO1 | 0.025/ 0.055 |

Power distribution electronic module

| Input power supply | Characteristics | Reference | Weight kg/lb |
|--------------------|---|-----------|-----------------|
| 24 V ~ | Power supply for the CANopen bus interface and I/O expansion modules Module colour: grey | TM5SPS3 | 0.025/ 0.055 |

Bus base

| Power supply | Characteristics | Unit reference | Weight kg/lb |
|--------------|--|----------------|-----------------|
| 24 V ~ | Use for TM5NCO1 and TM5SPS3 electronic modules Supplied with 2 protective plates TM5ACPL10 and TM5ACPR10 Colour of the base: white | TM5ACBN1 | 0.020/ 0.044 |

Terminal block

| Used for | Characteristics | Unit reference | Weight kg/lb |
|--|--|----------------|-----------------|
| Power distribution electronic module TM5SPS3 | 12 spring terminals Terminal block colour: grey | TM5ACTB12PS | 0.016/ 0.035 |

Accessories

| Description | Use for | Colour | Sold in lots of | Unit reference | Weight kg/lb |
|--|---|-------------|-----------------|----------------|-----------------|
| Plain text cover holder (label-holder) | Labelling the I/O channel terminal blocks | Transparent | 100 | TM5ACTCH100 | 0.200/ 0.441 |
| Terminal block shield locking clip (Order with plain text cover holder TM5ACTCH100) | Locking plain text cover holder TM5ACTCH100 | Transparent | 100 | TM5ACTLC100 | 0.100/ 0.220 |
| Precut sheet of paper labels | Plain text cover holder TM5ACTCH100 | White | 100 | TM5ACTLS100 | |
| Coloured plastic identifiers | Labelling 16 connection channel terminals | White | 1 | TM5ACLITW1 | 0.015/ 0.033 |
| | | Red | 1 | TM5ACLITR1 | |
| | | Blue | 1 | TM5ACLITB1 | |
| Metal tool | Inserting/removing TM5ACLIT●1 identifiers | Black | 1 | TM5ACLT1 | 0.030/ 0.066 |
| | | | | | |
| Retaining plates for bus bases | Held on the left side | White | 10 | TM5ACLPL10 | 0.004/ 0.009 |
| | Held on the right side | White | 10 | TM5ACLPR10 | |
| Locking clips | For electronic modules | Black | 100 | TM5ACADL100 | 0.001/ 0.002 |

Interface module kit

| Description | Composition | Reference | Weight kg/lb |
|--|--|-----------|-----------------|
| Kit including a CANopen electronic interface module, a power distribution electronic module, a bus base and a terminal block | TM5NCO1 + TM5SPS3 + TM5ACBN1 + TM5ACTB12PS | TM5NCO1K | 0.076/ 0.168 |

Configuration software

- SoMachine software, see page 5/2
- Performance distributed I/O configuration software, please consult our site www.schneider-electric.com

(1) Modicon TM5 Transmitter/Receiver modules (see page 3/38)

Communication

Distributed I/O on CANopen bus with Modicon TM7 interface blocks IP 67 for Modicon M258 logic controller and Modicon LMC058 motion controller

Applications

CANopen bus interface with digital I/O



Degree of protection

| | |
|-------|-------|
| IP 67 | IP 67 |
|-------|-------|

Type of housing

| | |
|---------|---------|
| Plastic | Plastic |
|---------|---------|

Modularity (number of channels)

| | | |
|---------------------------------|--|---|
| Max. number of digital channels | 8 channels configurable as inputs or outputs | 16 channels configurable as inputs or outputs |
| Digital inputs | 0...8 according to software configuration | 0...16 according to software configuration |
| Digital outputs | 0...8 according to software configuration | 0...16 according to software configuration |

Digital inputs

| | | |
|------------------------|-------------------|-------------------|
| Voltage/current | 24 V \pm 4.4 mA | 24 V \pm 4.4 mA |
| Type | Sink (1) | Sink (1) |
| IEC 61131-2 conformity | Type 1 | Type 1 |

Digital outputs

| | | |
|---------------------------------|-----------------------|-----------------------|
| Voltage | 24 V \pm | 24 V \pm |
| Type | Transistor/Source (2) | Transistor/Source (2) |
| Current per output | 0.5 A max. | 0.5 A max. |
| Current per interface I/O block | 4 A max. | 4 A max. |

Sensor/actuator power supply

| | | |
|--------------------|--|--|
| Voltage | 24 V \pm | 24 V \pm |
| Max. current | 500 mA for all channels | 500 mA for all channels |
| Protection against | Overloads, short-circuits and reverse polarity | Overloads, short-circuits and reverse polarity |

Connection

| | | | |
|----------------------------------|----------------------|--|--|
| CANopen bus | Bus input connector | A-coded 5-way male M12 | A-coded 5-way male M12 |
| | Bus output connector | - | A-coded 5-way female M12 |
| TM7 expansion bus | Bus input connector | - | - |
| | Bus output connector | B-coded 4-way female M12 | B-coded 4-way female M12 |
| Digital I/O channels | Sensor connector | 3-way female M8, 1 channel per connector | 3-way female M8, 1 channel per connector |
| | Actuator connector | 3-way female M8, 1 channel per connector | 3-way female M8, 1 channel per connector |
| Interface I/O block power supply | Input connector | 4-way male M8 | 4-way male M8 |
| | Output connector | 4-way female M8 | 4-way female M8 |

Diagnostics

| | | |
|------------------------|----------------|-----|
| By interface I/O block | Yes | Yes |
| By channel | Yes | Yes |
| By communication | On CANopen bus | Yes |
| | On TM7 bus | Yes |

Type of CANopen interface I/O block

| | |
|-------------------|-------------------|
| TM7NCOM08B | TM7NCOM16B |
|-------------------|-------------------|

Pages

| | |
|------|--|
| 4/33 | |
|------|--|

(1) Sink inputs: positive logic
(2) Source outputs: positive logic

Degree of protection

| |
|-------|
| IP 67 |
|-------|

Type of housing

| |
|---------|
| Plastic |
|---------|

Modularity (number of channels)

| |
|---|
| 16 channels configurable as inputs or outputs |
| 0...16 according to software configuration |
| 0...16 according to software configuration |

Digital inputs

| |
|-------------------|
| 24 V \pm 4.4 mA |
| Sink (1) |
| Type 1 |

Digital outputs

| |
|-----------------------|
| 24 V \pm |
| Transistor/Source (2) |
| 0.5 A max. |
| 4 A max. |

Sensor/actuator power supply

| |
|--|
| 24 V \pm |
| 500 mA for all channels |
| Overloads, short-circuits and reverse polarity |

Connection

| | | |
|----------------------------------|----------------------|--|
| CANopen bus | Bus input connector | A-coded 5-way male M12 |
| | Bus output connector | A-coded 5-way female M12 |
| TM7 expansion bus | Bus input connector | - |
| | Bus output connector | B-coded 4-way female M12 |
| Digital I/O channels | Sensor connector | A-coded 5-way female M12, 2 channels per connector |
| | Actuator connector | A-coded 5-way female M12, 2 channels per connector |
| Interface I/O block power supply | Input connector | 4-way male M8 |
| | Output connector | 4-way female M8 |

Diagnostics

| |
|-----|
| Yes |
| Yes |
| Yes |
| Yes |

Type of CANopen interface I/O block

| |
|-------------------|
| TM7NCOM16A |
|-------------------|

Pages

| |
|------|
| 4/33 |
|------|

Communication

Distributed I/O on CANopen bus with Modicon TM7 interface blocks IP 67 for Modicon M258 logic controller and Modicon LMC058 motion controller

Presentation

To enhance its "Flexible machine Control" concept, a key component of MachineStruxure™, Schneider Electric offers Modicon TM7 IP 67 blocks for mounting outside electrical cabinets, directly on the installation. The IP 67 protection of these blocks enables them to be used within processes or machines in harsh environments (splashing water, oil, dust, etc.).

They have the following characteristics:

- Dust and damp proof
- Robust and compact
- Rapid wiring, economical to use

The CANopen interface I/O blocks enable sensors and actuators distributed over machines to be connected via the CANopen fieldbus. These interface I/O blocks communicate on the bus. They have one part for connecting sensors and actuators using M8 or M12 connectors and one part for connection to the CANopen fieldbus.

The interface I/O block offer comprises IP 67 blocks that connect to a CANopen bus and have digital channels that can be configured as inputs or outputs, including:

- A CANopen interface block with 8 configurable I/O for connection via M8 connector
- Two CANopen interface blocks with 16 configurable I/O

This offer is completed with :

- Digital I/O expansion blocks, see page 3/64
- Analog input expansion blocks, see page 3/64
- Power distribution block, see page 3/64
- Connection accessories, see page 4/34

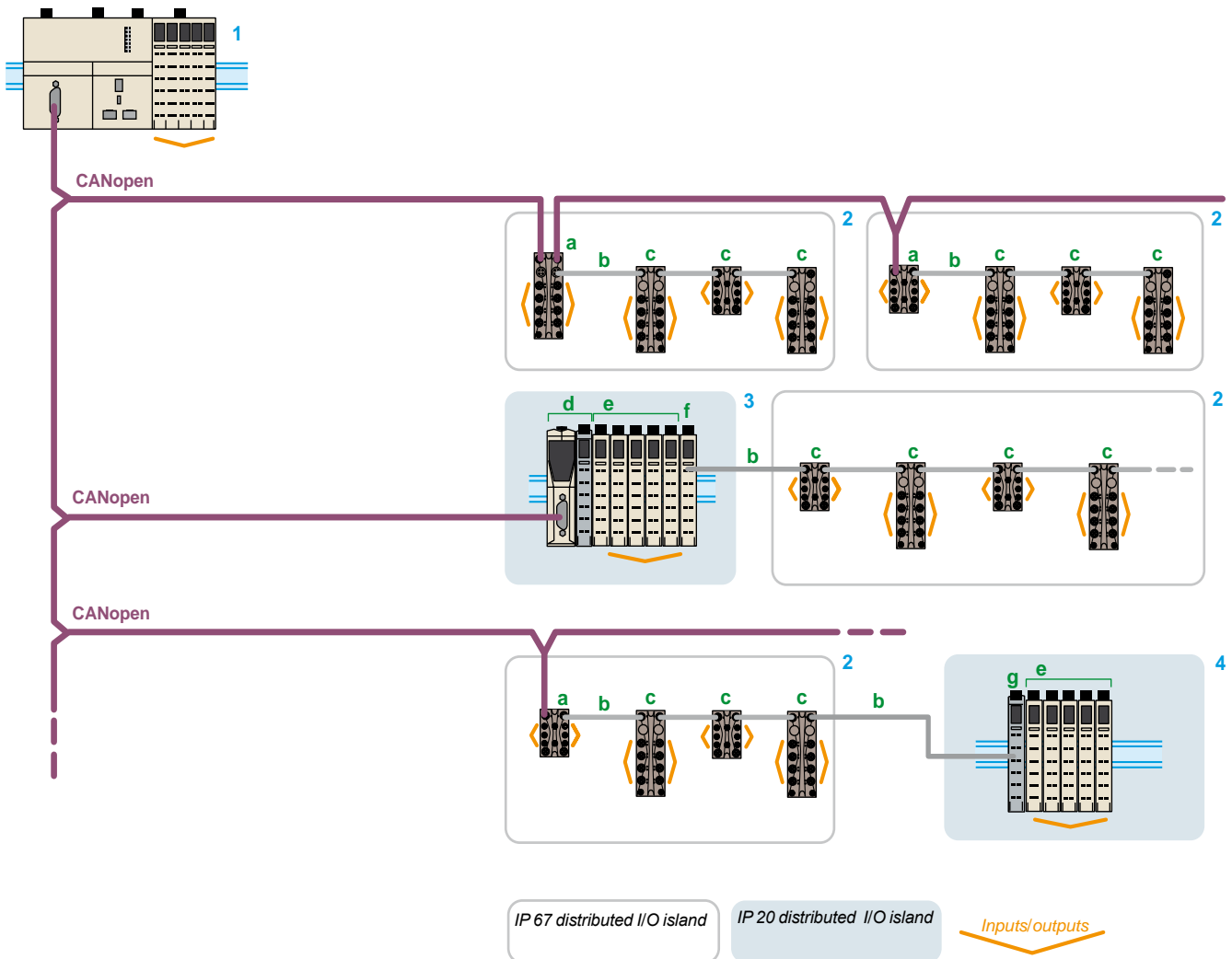

- 1 Modicon M258 logic controller or Modicon LMC058 motion controller: CANopen bus masters.
- 2 IP 67 distributed I/O islands. Composition: TM7 CANopen interface block (slave) with digital I/O (a) + TM7 expansion bus cable (b) + TM7 digital/analog blocks (c) (1).
- 3 IP 20 distributed I/O island. Composition: TM5 CANopen interface module (slave) (d) + TM5 compact (2) or TM5 modules (e) (3) + transmitter module TM5SBET7 (f) (4).
- 4 IP 20 distributed I/O island. Composition: receiver module TM5SBER2 (g) (4) + TM5 modules (e) (3).

(1) Modicon TM7 Digital or analog block, see page 3/64
 (2) Modicon TM5 compact blocks, see page 3/38
 (3) Modicon TM5 digital modules, see page 3/42. Modicon TM5 analog modules, see page 3/50
 (4) Modicon TM5 transmitter and receiver modules, see page 3/62



CANopen interface block with digital I/O



Communication bus status LED
Channel status LED
Power supply status LED

Diagnostics functions

The diagnostic monitoring of faults is indicated by LEDs on CANopen interface I/O blocks, expansion blocks and power distribution blocks and informs the control system (M258 logic controller or LMC058 motion controller) via the TM7 bus.

Each Modicon TM7 block has LEDs

- To display the status of the TM7 bus, the channel and the power supply
- For quick, precise location of a fault

There are several levels of diagnostics:

- Diagnostics per channel:
 - State of inputs
 - State of outputs
- Communication bus diagnostics:
 - On CAN bus (CANopen interface I/O block)
 - On TM7 expansion bus (CANopen interface I/O block and I/O expansion blocks).

Specifications

| | |
|---|---|
| Conformity with standards | IEC 61131-2 |
| Product certifications | CE, cURus, GOST-R and c-Tick, ATEX (II 3g EEx nA II T5, IP 67, Ta = 0...60°C) |
| Temperature | Operation: -10...+60°C (14...140°F) Storage: -25...+85°C (-13...185°F) |
| Relative humidity | 5...95% (without condensation) |
| Degree of pollution conforming to IEC 60664 | 2 |
| Degree of protection conforming to IEC 61131-2 | IP 67 |
| Altitude | Operation: 0...2000 m (0...6560 ft.) (1) Storage: 0...3000 m (0...9842 ft.) |
| Vibration resistance conforming to IEC 60721-3-5 Class 5M3 | DIN rail mounted 7.5 mm (0.295 in.) 2...8 Hz fixed amplitude 20 m/s ² (2 gn) 8...200 Hz fixed acceleration 40 m/s ² (4 gn) 200...500 Hz fixed acceleration |
| Shock resistance conforming to IEC 60721-3-5 Class 5M3 | 300 m/s ² (30 gn) for 11 ms, 1/2 sine wave, type 1 shock |
| Connectors | Type: M8 and/or M12 Number of operations: 50 min. |

Electromagnetic compatibility

| | |
|---|---|
| Electrostatic discharges conforming to IEC/EN 61000-4-2 | ± 8 kV, criterion B (air discharge) ± 4 kV, criterion B (direct discharge) |
| Electromagnetic fields conforming to IEC/EN 61000-4-3 | 10 V/m, amplitude modulation 80% at 1 kHz (80 MHz...2 GHz) 1 V/m (2...2.7 GHz) |
| Fast transients conforming to IEC/EN 61000-4-4 | Supply: 2 kV, criterion B I/O: 1 kV, criterion B Shielded cable: 1 kV, criterion B Repetition frequency: 5 and 100 kHz |
| Immunity to overvoltages, 24 V $\overline{\text{---}}$ circuit conforming to IEC/EN 61000-4-5 | Supply: □ 1 kV (12 Ω), criterion B in common mode □ 0.5 kV (2 Ω), criterion B in differential mode Unshielded links: □ 1 kV (42 Ω), criterion B in common mode □ 0.5 kV (42 Ω), criterion B in differential mode Shielded links: □ 1 kV (12 Ω), criterion B in common mode □ 0.5 kV (2 Ω), criterion B in differential mode |
| Induced magnetic fields conforming to IEC/EN 61000-4-6 | Line supply, I/O signal connections > 10 m (32.8 ft.) Functional earth connection: 10 Vrms, criterion A, amplitude modulation 80% at 1 kHz (150...80 MHz) |
| Conducted emissions conforming to EN 55011 (IEC/CISPR11) | 150...500 kHz, peak 79 dB μ V 500 kHz...30 MHz, peak 73 dB μ V |
| Radiated emissions conforming to EN 55011 (IEC/CISPR11) | 30...230 MHz, 10 m (32.8 ft) at 40 dB (μ V/m) 230 MHz...1 GHz, 10 m (32.8 ft) at 47 dB (μ V/m) |

(1) Temperature reduction of 0.5°C (32.9°F) for every additional 100 m (328 ft.) altitude above 2000 m (6560 ft.). Refer to the instruction sheet for each product, downloadable from www.schneider-electric.com

Communication

Distributed I/O on CANOpen bus with Modicon TM7 interface blocks IP 67

for Modicon M258 logic controller and Modicon LMC058 motion controller

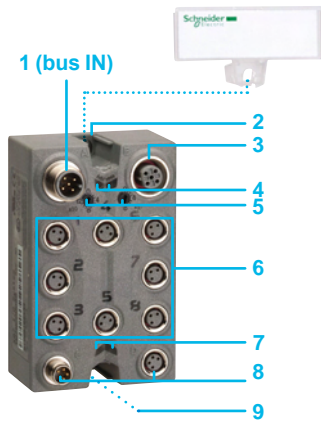

Description

CANOpen interface I/O blocks

CANOpen **8-channel** interface I/O blocks have the following on the front panel:

- 1 A male M12 connector (bus IN) for connecting the CANOpen bus
- 2 A slot for the interface I/O block label (1)
- 3 A female M12 connector for connecting the TM7 expansion bus
- 4 Two bus diagnostic LEDs
- 5 CANOpen address settings rotary switches
- 6 Eight female M8 connectors for connecting sensors and actuators with eight LEDs for indicating channel status
- 7 Two LEDs indicating the status of the sensor and actuator 24 V $\overline{\text{DC}}$ power supplies
- 8 Two M8 connectors for connecting the 24 V $\overline{\text{DC}}$ sensor and actuator power supplies: male for PWR IN, female for PWR OUT
- 9 Fixing using two \varnothing 4 screws (not supplied) and connection of the functional earth when fixing the block on a metal support

4

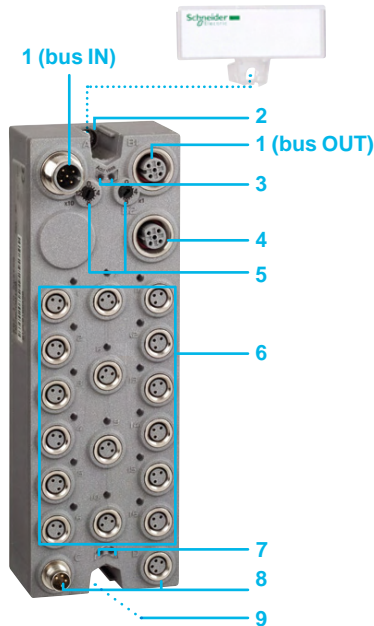

CANOpen **16-channel** interface I/O blocks have the following on the front panel:

- 1 A male M12 connector (bus IN) and a female M12 connector (bus OUT) for connecting the CANOpen bus
- 2 A slot for the interface I/O block label (1)
- 3 Two bus diagnostic LEDs
- 4 A female M12 connector for connecting the TM7 expansion bus
- 5 CANOpen address settings rotary switches
- 6 Eight M12 connectors (2 channels per connector) or sixteen M8 connectors for connecting sensors and actuators with LEDs for indicating channel status
- 7 Two LEDs indicating the status of the sensor and actuator 24 V $\overline{\text{DC}}$ power supplies
- 8 Two M8 connectors for connecting the 24 V $\overline{\text{DC}}$ sensor and actuator power supplies: male for PWR IN, female for PWR OUT
- 9 Fixing using two \varnothing 4 screws (not supplied) and connection of the functional earth when fixing the block on a metal support

(1) Label-holder supplied with IP 67 block

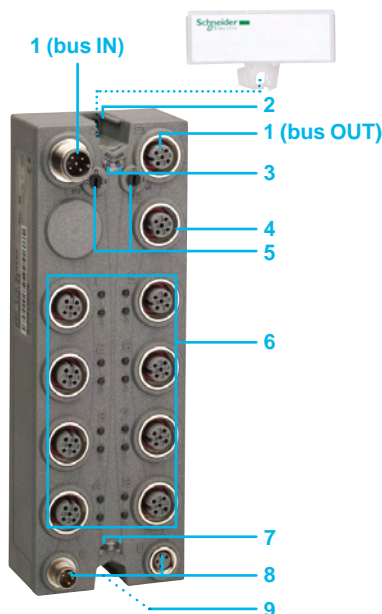

Communication

Distributed I/O on CANOpen bus with Modicon TM7 interface blocks IP 67
for Modicon M258 logic controller and Modicon LMC058 motion controller



TM7NCOM08B



TM7NCOM16B



TM7NCOM16A

Modicon TM7 CANOpen interface blocks with digital I/O

| Max. no. of channels | Number, type of inputs | Number, type of outputs | Sensor/actuator connection | Communication bus | Reference | Weight kg/lb |
|----------------------|------------------------|---------------------------|----------------------------|-------------------|-------------------|--------------|
| 8 I/O | 8, sink (1) | 8, transistor/source (2) | 8 female M8 connectors | CANopen, TM7 bus | TM7NCOM08B | 0.195/0.430 |
| 16 I/O | 16, sink (1) | 16, transistor/source (2) | 16 female M8 connectors | CANopen, TM7 bus | TM7NCOM16B | 0.320/0.705 |
| | 16, sink (1) | 16, transistor/source (2) | 8 female M12 connectors | CANopen, TM7 bus | TM7NCOM16A | 0.320/0.705 |

(1) Sink inputs: positive logic

(2) Source outputs: positive logic

Architecture, connecting cables

See page 4/38

Modicon TM7 I/O expansion blocks

See page 3/64

Connection accessories

See page 4/34

Separate parts

See page 4/37

Configuration software

- SoMachine software, see page 5/2
- Performance distributed I/O configuration software, please refer to our website www.schneider-electric.com

Communication

Distributed I/O on CANopen bus with Modicon
TM7 interface blocks IP 67
for Modicon M258 logic controller and Modicon LMC058
motion controller

CANopen architecture

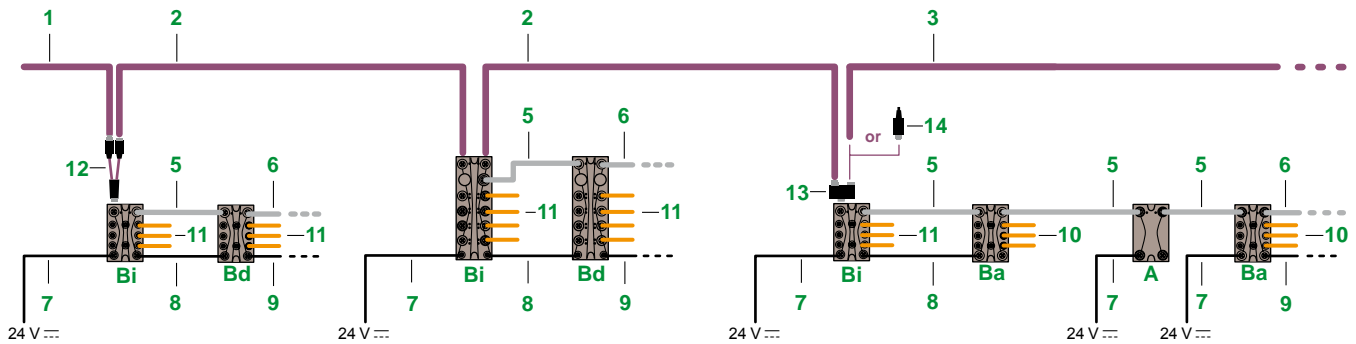

TM7 expansion bus architecture

TM5 NCO1 + TM5 SBET7

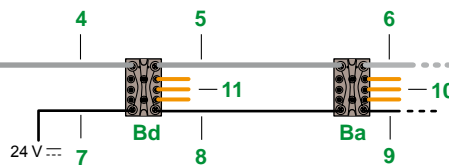
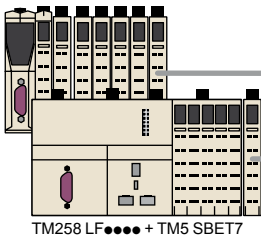

- A** Power distribution block
- Ba** Analog I/O expansion block
- Bd** Digital I/O expansion block
- Bi** CANopen interface I/O block

4

References

Cables for connection to the CANopen bus

| Designation | Description | Item no. | Length m/ft | Reference | Weight kg/lb |
|--|---|----------|-------------|----------------|--------------|
| CANopen bus connection cables (bus IN) | Equipped with one A-coded 5-way angled female M12 connector and 1 flying lead | 1 | 1/3.28 | TCSCCN2FNX1SA | 0.089/0.196 |
| | | | 3/9.843 | TCSCCN2FNX3SA | 0.195/0.430 |
| | | | 10/32.81 | TCSCCN2FNX10SA | 0.563/1.241 |
| | Equipped with one A-coded 5-way straight female M12 connector and 1 flying lead | 1 | 1/3.28 | TCSCCN1FNX1SA | 0.089/0.196 |
| | | | 3/9.843 | TCSCCN1FNX3SA | 0.195/0.430 |
| | | | 10/32.81 | TCSCCN1FNX10SA | 0.563/1.241 |
| CANopen bus daisy chain cables | Equipped with two A-coded 5-way angled M12 connectors, 1 male and 1 female, at each end | 2 | 0.3/0.98 | TCSCCN2M2F03 | 0.090/0.198 |
| | | | 1/3.28 | TCSCCN2M2F1 | 0.127/0.280 |
| | | | 2/6.56 | TCSCCN2M2F2 | 0.179/0.395 |
| | | | 5/16.40 | TCSCCN2M2F5 | 0.337/0.743 |
| | | | 10/32.81 | TCSCCN2M2F10 | 0.600/1.323 |
| | | | 15/49.21 | TCSCCN2M2F15 | 0.863/1.903 |
| | Equipped with two A-coded 5-way straight M12 connectors, 1 male and 1 female, at each end | 2 | 0.3/0.98 | TCSCCN1M1F03 | 0.090/0.198 |
| | | | 1/3.28 | TCSCCN1M1F1 | 0.127/0.280 |
| | | | 2/6.56 | TCSCCN1M1F2 | 0.179/0.395 |
| | | | 5/16.40 | TCSCCN1M1F5 | 0.337/0.743 |
| | | | 10/32.81 | TCSCCN1M1F10 | 0.600/1.323 |
| | | | 15/49.21 | TCSCCN1M1F15 | 0.863/1.903 |
| CANopen bus connection cables (bus OUT) | Equipped with one A-coded 5-way angled male M12 connector and 1 flying lead | 3 | 1/3.28 | TCSCCN2MNX1SA | 0.089/0.196 |
| | | | 3/9.843 | TCSCCN2MNX3SA | 0.195/0.430 |
| | | | 10/32.81 | TCSCCN2MNX10SA | 0.563/1.241 |
| | Equipped with one A-coded 5-way straight male M12 connector and 1 flying lead | 3 | 1/3.28 | TCSCCN1MNX1SA | 0.089/0.196 |
| | | | 3/9.843 | TCSCCN1MNX3SA | 0.195/0.430 |
| | | | 10/32.81 | TCSCCN1MNX10SA | 0.563/1.241 |

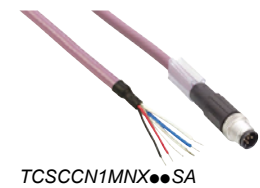
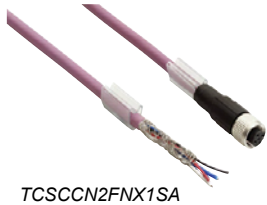

TM7 expansion bus cables

| | | | | | |
|--|---|---|----------|---------------|-------------|
| TM7 expansion bus cables (bus IN) | Equipped with one B-coded 4-way angled female M12 connector and 1 flying lead | 4 | 1/3.28 | TCSXCN2FNX1E | 0.089/0.196 |
| | | | 3/9.843 | TCSXCN2FNX3E | 0.195/0.430 |
| | | | 10/32.81 | TCSXCN2FNX10E | 0.563/1.241 |
| | | | 25/82.02 | TCSXCN2FNX25E | 1.352/2.981 |
| | Equipped with one B-coded 4-way straight female M12 connector and 1 flying lead | 4 | 1/3.28 | TCSXCN1FNX1E | 0.089/0.196 |
| | | | 3/9.843 | TCSXCN1FNX3E | 0.195/0.430 |
| | | | 10/32.81 | TCSXCN1FNX10E | 0.563/1.241 |
| | | | 25/82.02 | TCSXCN1FNX25E | 1.352/2.981 |

Communication

Distributed I/O on CANopen bus with Modicon
TM7 interface blocks IP 67
for Modicon M258 logic controller and Modicon LMC058
motion controller

Connection accessories (continued)

| Designation | Description | Item no. | Length m/ft | Reference | Weight kg/lb | | | |
|--|---|---|--|--|--------------|----------|---------------|-------------|
| TM7 expansion bus cables (continued) | | | | | | | | |
| TM7 bus daisy chain cables | Equipped with two B-coded 4-way angled M12 connectors, 1 male and 1 female, at each end | 5 | 0.3/0.98 | TCSXC2M2F03E | 0.090/0.198 | | | |
| | | | 1/3.28 | TCSXC2M2F1E | 0.127/0.280 | | | |
| | | | 2/6.56 | TCSXC2M2F2E | 0.179/0.395 | | | |
| | | | 5/16.40 | TCSXC2M2F5E | 0.337/0.743 | | | |
| | | | 10/32.81 | TCSXC2M2F10E | 0.600/1.323 | | | |
| | Equipped with two B-coded 4-way straight M12 connectors, 1 male and 1 female, at each end | 5 | 0.3/0.98 | TCSXC1M1F03E | 0.090/0.198 | | | |
| | | | 1/3.28 | TCSXC1M1F1E | 0.127/0.280 | | | |
| | | | 2/6.56 | TCSXC1M1F2E | 0.179/0.395 | | | |
| | | | 5/16.40 | TCSXC1M1F5E | 0.337/0.743 | | | |
| | | | 10/32.81 | TCSXC1M1F10E | 0.600/1.323 | | | |
| | | | 15/49.21 | TCSXC1M1F15E | 0.863/1.903 | | | |
| | | | 1/3.28 | TCSXC2MNX1E | 0.089/0.196 | | | |
| | | | 3/9.843 | TCSXC2MNX3E | 0.195/0.430 | | | |
| | | | 10/32.81 | TCSXC2MNX10E | 0.563/1.241 | | | |
| | | | 25/82.02 | TCSXC2MNX25E | 1.352/2.981 | | | |
| TM7 expansion bus cables (bus OUT) | Equipped with one B-coded 4-way angled male M12 connector and 1 flying lead | 6 | 1/3.28 | TCSXC2MNX1E | 0.089/0.196 | | | |
| | | | 3/9.843 | TCSXC2MNX3E | 0.195/0.430 | | | |
| | | | 10/32.81 | TCSXC2MNX10E | 0.563/1.241 | | | |
| | | | 25/82.02 | TCSXC2MNX25E | 1.352/2.981 | | | |
| | | | 1/3.28 | TCSXC1MNX1E | 0.089/0.196 | | | |
| | Equipped with one B-coded 4-way straight male M12 connector and 1 flying lead | 6 | 1/3.28 | TCSXC1MNX1E | 0.089/0.196 | | | |
| | | | 3/9.843 | TCSXC1MNX3E | 0.195/0.430 | | | |
| | | | 10/32.81 | TCSXC1MNX10E | 0.563/1.241 | | | |
| | | | 25/82.02 | TCSXC1MNX25E | 1.352/2.981 | | | |
| | | | Power distribution cables | | | | | |
| | | | Power IN power distribution cables | Equipped with one 4-way angled female M8 connector and 1 flying lead | 7 | 1/3.28 | TCSXCNEFNX1V | 0.041/0.090 |
| | | | | | | 3/9.843 | TCSXCNEFNX3V | 0.105/0.231 |
| | | | | | | 10/32.81 | TCSXCNEFNX10V | 0.329/0.725 |
| | | | | | | 25/82.02 | TCSXCNEFNX25V | 0.809/1.784 |
| | | | | | | 1/3.28 | TCSXCNDFNX1V | 0.041/0.090 |
| Equipped with one 4-way straight female M8 connector and 1 flying lead | 7 | 1/3.28 | | TCSXCNDFNX1V | 0.041/0.090 | | | |
| | | 3/9.843 | | TCSXCNDFNX3V | 0.105/0.231 | | | |
| | | 10/32.81 | | TCSXCNDFNX10V | 0.329/0.725 | | | |
| | | 25/82.02 | | TCSXCNDFNX25V | 0.809/1.784 | | | |
| | | Power daisy chain cables | | | | | | |
| | | Power IN power distribution cables | | Equipped with two 4-way angled M8 connectors, 1 male and 1 female, at each end | 8 | 0.3/0.98 | TCSXCNEMEF03V | 0.028/0.062 |
| | | | | | | 1/3.28 | TCSXCNEMEF1V | 0.050/0.110 |
| | | | | | | 2/6.56 | TCSXCNEMEF2V | 0.082/0.181 |
| | | | | | | 5/16.40 | TCSXCNEMEF5V | 0.178/0.392 |
| | | | | | | 10/32.81 | TCSXCNEMEF10V | 0.338/0.745 |
| Equipped with two 4-way straight M8 connectors, 1 male and 1 female, at each end | 8 | | 0.3/0.98 | TCSXCNDMDF03V | 0.105/0.231 | | | |
| | | | 1/3.28 | TCSXCNDMDF1V | 0.329/0.725 | | | |
| | | | 2/6.56 | TCSXCNDMDF2V | 0.809/1.784 | | | |
| | | | 5/16.40 | TCSXCNDMDF5V | 0.105/0.231 | | | |
| | | | 10/32.81 | TCSXCNDMDF10V | 0.329/0.725 | | | |
| | | | 15/49.21 | TCSXCNDMDF15V | 0.809/1.784 | | | |
| | | | Power OUT power distribution cables | | | | | |
| | | | Power OUT power distribution cables | Equipped with one 4-way angled male M8 connector and 1 flying lead | 9 | 1/3.28 | TCSXCNEYNX1V | 0.041/0.090 |
| | | | | | | 3/9.843 | TCSXCNEYNX3V | 0.105/0.231 |
| | | | | | | 10/32.81 | TCSXCNEYNX10V | 0.329/0.725 |
| 25/82.02 | TCSXCNEYNX25V | 0.809/1.784 | | | | | | |
| 1/3.28 | TCSXCNDMNX1V | 0.041/0.090 | | | | | | |
| Equipped with one 4-way straight male M8 connector and 1 flying lead | 9 | 1/3.28 | | TCSXCNDMNX1V | 0.041/0.090 | | | |
| | | 3/9.843 | | TCSXCNDMNX3V | 0.105/0.231 | | | |
| | | 10/32.81 | | TCSXCNDMNX10V | 0.329/0.725 | | | |
| | | 25/82.02 | | TCSXCNDMNX25V | 0.809/1.784 | | | |
| | | Cables for connecting analog sensors and actuators | | | | | | |
| | | Cables for connecting sensors and actuators | | Equipped with one A-coded 5-way angled male M12 connector and 1 flying lead | 10 | 2/6.56 | TCSXC2M2SA | 0.143/0.315 |
| | | | | | | 5/16.40 | TCSXC2M5SA | 0.258/0.569 |
| | | | | | | 15/49.21 | TCSXC2M15SA | 0.546/1.204 |
| | | | | Equipped with one A-coded 5-way straight male M12 connector and 1 flying lead | 10 | 2/6.56 | TCSXC1M2SA | 0.143/0.315 |
| | | | | | | 5/16.40 | TCSXC1M5SA | 0.258/0.569 |
| 15/49.21 | TCSXC1M15SA | | 0.546/1.204 | | | | | |
| Cables for connecting digital sensors and actuators | | | | | | | | |
| Please consult our "Detection for OsiSense automation solutions" catalogue | | 11 | | | | | | |
| Accessories | | | | | | | | |
| See next page | | 12 | | | | | | |
| | | 13 | | | | | | |
| | | 14 | | | | | | |



TCSXC1M1F●●E



TCSXC1MNX●●E



TCSXCNDFNX●●V



TCSXCNDMDF●●V



TCSXCNEYNX●●V



TCSXC1M2SA

Communication

Distributed I/O on CANOpen bus with Modicon TM7 interface blocks IP 67 for Modicon M258 logic controller and Modicon LMC058 motion controller



TM7ACYCJ



TM7ACYC



TM7ACTHA

Connection accessories

| Description | Composition | Item no. | Reference | Weight kg/lb |
|---|---|----------|-----------|--------------|
| CAN bus Y cable | Equipped with 2x5-way M12 connectors, 1 male and 1 female, and at the other end: 1x5-way male M12 connector | 12 | TM7ACYCJ | 0.031/0.068 |
| CAN Y connector | For connecting 2xM12 connectors, 1 male and 1 female, to male M12 connector on the expansion block | 13 | TM7ACYC | 0.100/0.220 |
| Line terminator (for end of bus) | Equipped with 1x5-way male M12 connector | 14 | TM7ACTLA | 0.023/0.051 |
| Connector with temperature probe for measurement by thermocouple (1) | Equipped with 1x5-way male M12 connector | – | TM7ACTHA | 0.100/0.220 |

(1) For use with the **TM7BAI4PLA** expansion block for measurement with compensation of the temperature of the connector.

Communication

Distributed I/O on CANopen bus with Modicon TM7 interface blocks IP 67
for Modicon M258 logic controller and Modicon LMC058 motion controller



TM7ACMP

Separate parts

| Description | Composition | Unit reference | Weight kg/lb |
|--|---|------------------|--------------|
| Sealing plugs (1) | For M8 connector for Modicon TM7 IP 67 blocks Lot of 50 | TM7ACCB | 0.100/0.220 |
| | For M12 connector for Modicon TM7 IP 67 blocks Lot of 50 | TM7ACCA | 0.100/0.220 |
| Mounting plate on  symmetrical DIN rail | For Modicon TM7 IP 67 blocks | TM7ACMP | 0.020/0.044 |
| | For Modicon TM7 IP 67 blocks Lot of 10 | TM7ACMP10 | 0.200/0.441 |
| Set of two screwdrivers | For tightening the rings on M8 and M12 connectors to the correct torque | TM7ACTW | 0.198/0.437 |

(1) The use of sealing plugs ensures that unused connectors on Modicon TM7 IP 67 blocks have IP 67 protection.

CANopen Performance architecture

Example of connection of a CANopen Performance architecture dedicated to machines and modular installations.

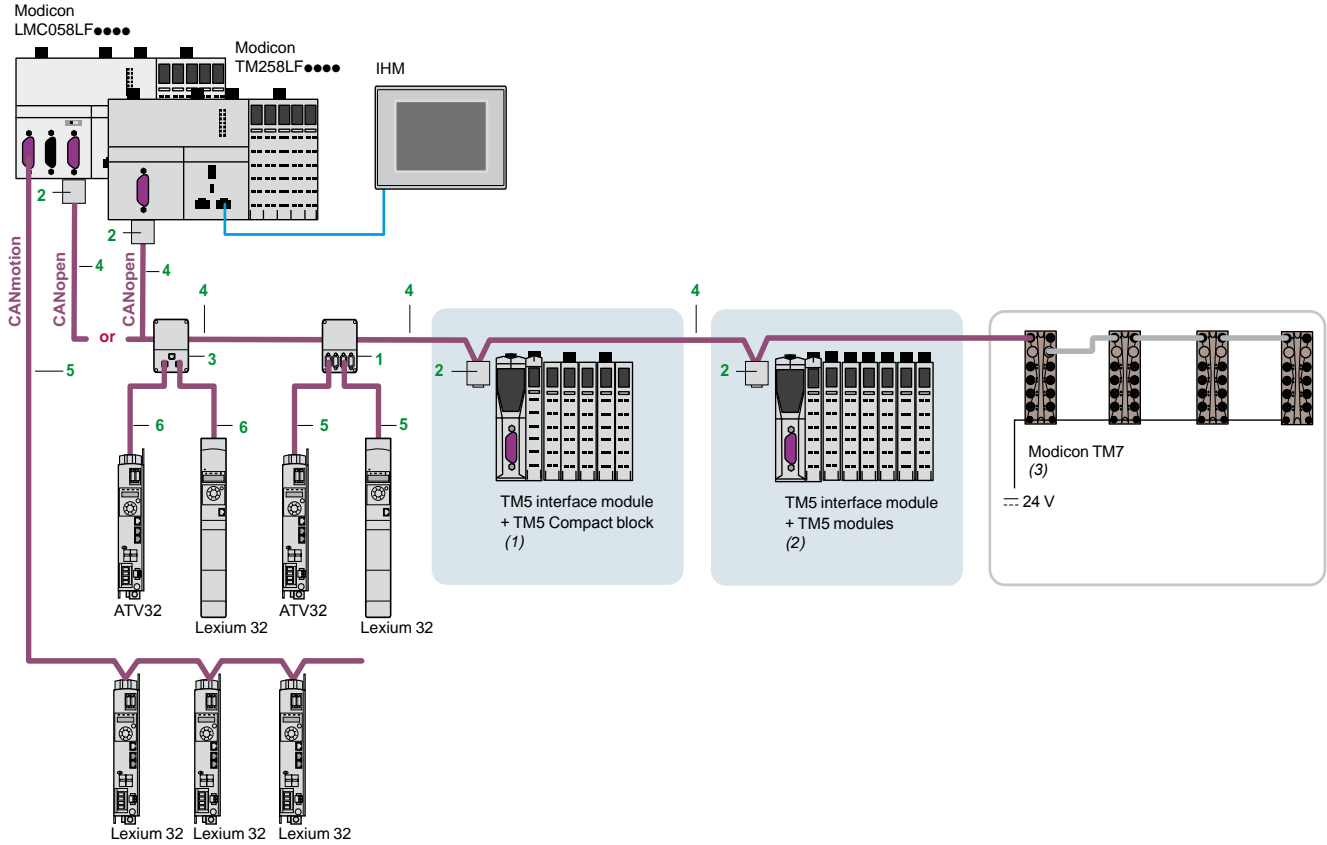

4

References

Standard tap junctions and connectors

| Designation | Description | Item no. | Length m/ft | Reference | Weight kg/lb | |
|--|---|----------|-------------|---------------|-----------------|-----------------|
| IP 20 CANopen tap junction | 4 SUB-D ports. Screw terminal block for connecting the trunk cables | 1 | – | TSXCANTDM4 | 0.196/ 0.432 | |
| | Line termination | | | | | |
| IP 20 connectors CANopen 9-way female SUB-D. Switch for line termination | 90° angled | 2 | – | TSXCANKCDF90T | 0.046/ 0.101 | |
| | Straight (4) | – | – | | TSXCANKCDF180T | 0.049/ 0.108 |
| | 90° angled with 9-way SUB-D for connecting a PC or diagnostic tool | – | – | | | TSXCANKCDF90TP |
| IP 20 CANopen tap junction for Altivar and Lexium | 2 RJ45 ports | 3 | – | VW3CANTAP2 | 0.250/ 0.551 | |



TSXCANTDM4



VW3CANTAP2



TSXCANKCDF90T



TSXCANKCDF180T



TSXCANKCDF90TP

(1) Modicon TM5 interface module (see page 4/24) + Modicon TM5 Compacts blocks (see page 3/38).

(2) Modicon TM5 interface module (see page 4/24) + Modicon TM5 modules: Digital modules (see page 3/42) ; Analog modules (see page 3/50) ; Expert module (see page 3/54).

(3) Modicon TM7 offer: TM7 IP 67 I/O blocks, expansion cable, and accessories (see page 3/64).

(4) For connection to Altivar IMC integrated controller card.

References (continued)

IP 20 standard cables and preassembled cordsets

| Designation | Description | Item no. | Length m/ft | Reference | Weight kg/lb | |
|--|--|--|-------------|---------------------|----------------------|-------------|
| CANopen cables (2 x AWG 22 2 x AWG 24) | For standard environment (1), CE marking: low smoke. Zero halogen. Flame-retardant (IEC 60332-1) | 4 | 50/164.04 | TSXCANCA50 | 4.930/ 16.174 | |
| | | | 100/328.08 | TSXCANCA100 | 8.800/ 28.871 | |
| | | | 300/984.24 | TSXCANCA300 | 24.560/80.577 | |
| | For standard environment (1), UL certification, CE marking: flame- retardant (IEC 60332-2) | 4 | 50/164.04 | TSXCANCB50 | 3.580/11.745 | |
| | | | 100/328.08 | TSXCANCB100 | 7.840/ 25.721 | |
| | | | 300/984.24 | TSXCANCB300 | 21.870/71.751 | |
| | For harsh environments (1) or mobile installations, CE marking: low smoke. Zero halogen. Flame-retardant (IEC 60332-1). Oil-resistant | 4 | 50/164.04 | TSXCANCD50 | 3.510/ 11.515 | |
| | | | 100/328.08 | TSXCANCD100 | 7.770/ 25.492 | |
| | | | 300/984.24 | TSXCANCD300 | 21.700/71.194 | |
| CANopen preassembled cordsets One 9-way female SUB-D connector at each end. | For standard environment (1), CE marking: low smoke. Zero halogen. Flame-retardant (IEC 60332-1) | - | 0.3/0.98 | TSXCANCADD03 | 0.091/0.201 | |
| | | | 1/3.28 | TSXCANCADD1 | 0.143/0.315 | |
| | | | 3/9.84 | TSXCANCADD3 | 0.295/0.650 | |
| | For standard environment (1), UL certification, CE marking: flame- retardant (IEC 60332-2) | - | 0.3/0.98 | TSXCANCBDD03 | 0.086/0.190 | |
| | | | 1/3.28 | TSXCANCBDD1 | 0.131/0.289 | |
| | | | 3/9.84 | TSXCANCBDD3 | 0.268/0.591 | |
| | CANopen preassembled cordsets | Cordsets with one 9-way female SUB-D connector and one RJ45 connector | 5 | 0.5/0.98 | TCSCCN4F3M05T | 0.100/0.220 |
| | | | | 1/3.28 | TCSCCN4F3M1T | 0.100/0.220 |
| | | | | 3/9.84 | TCSCCN4F3M3T | 0.160/0.353 |
| Cordsets with two 9-way SUB-D connectors, one female and one male | | - | 0.5/0.98 | TLACDCBA005 | 0.100/0.220 | |
| | | | 1.5/4.92 | TLACDCBA015 | 0.120/0.265 | |
| | | | 3/9.84 | TLACDCBA030 | 0.190/0.419 | |
| 5/16.40 | TLACDCBA050 | 0.350/0.772 | | | | |

IP 20 connection accessories

| | | | | | |
|---|--|---|----------|-----------------------|-------------|
| CANopen connector for Altivar 71 (3) | 9-way female SUB-D Switch for line termination. Cables exit at 180° | - | - | VW3CANKCDF180T | 0.100/0.220 |
| Adaptor for Altivar 71 drive | SUB-D to RJ45 CANopen adaptor | - | - | VW3CANA71 | 0.100/0.220 |
| CANopen preassembled cordsets | 1 RJ45 connector at each end | 6 | 0.3/0.98 | VW3CANCARR03 | 0.100/0.220 |
| | | | 1/3.28 | VW3CANCARR1 | 0.100/0.220 |
| CANopen bus adaptor for Lexium 17D | Hardware interface for CANopen- compliant link + 1 connector for a PC terminal | - | - | AM02CA001V000 | 0.110/0.243 |
| Y-connector | CANopen/Modbus | - | - | TCSCTN011M11F | 0.100/0.220 |

IP 67 cables and preassembled cordsets, IP 67 connection accessories for Modicon TM7 blocks

(see page 4/34)

(1) Standard environment: no particular environmental constraints, operating temperature between +5°C and +60°C, and in fixed installations

Harsh environment: resistance to hydrocarbons, industrial oils, detergents, solder splashes, relative humidity up to 100%, saline atmosphere, significant temperature variations, operating temperature between -10°C and +70°C, or in mobile installations.

(2) Cordset equipped with a line terminator.

(3) For ATV71H●●●M3, ATV71HD11M3X, HD15M3X, ATV71H075N4... HD18N4 drives, this connector can be replaced by the TSXCANKCDF180T connector.



VW3CANA71



AM02CA001V000

Compatibility of offers

Modicon TM4 communication modules

- > Modicon M241 logic controllers
- > Modicon M251 logic controllers

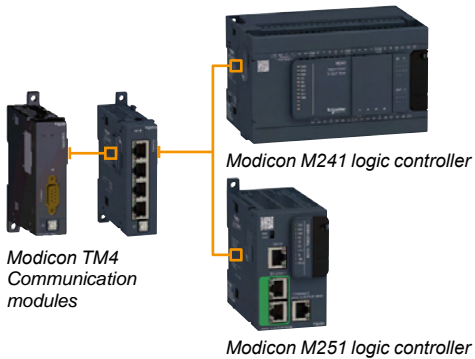

4

Presentation

Applications

The Modicon TM4 offer enhances the connectivity for Modicon M241 and M251 logic controllers.

Two communication module models are available:

- The **TM4ES4** Ethernet switch module (offering, only on controllers without embedded Ethernet, an Ethernet connection with 4 ports).
- The **TM4PDPS1** Profibus DP slave module.

■ Ethernet switch module

The **TM4ES4** module is a 4-port Ethernet interface (10/100 Mbps, MDI/MDIX) with the following protocols: Modbus TCP (Client/Server), Ethernet IP (adapter), UDP, TCP, SNMP and SoMachine.

- The **TM4ES4** module is ready for use as soon as it is connected to the communication bus of M241 controllers.
- This module is used to add the Ethernet function to TM241C24● and TM241C40● controllers without embedded Ethernet port while offering the additional functionality of an Ethernet switch.
- When connected to logic controllers with embedded Ethernet port type TM241CE24●●●, TM241CE40●●●, or on a TM251MES● controller it is a 4 port stand-alone switch: the communication between the TM4ES4 module and the Modicon M241 and M251 controllers is not done automatically by the bus connector.

■ Profibus DP slave module

The **TM4PDPS1** communication module can be used to configure a slave connection on the Profibus DP bus.

Association rules

Up to 3 communication modules (total) can be added on the left of M241 and M251 logic controllers, in order to increase their possibilities of connection to the Ethernet and Profibus networks.

- On controllers without embedded Ethernet port (TM241C24●●● and TM241C40●●●): it is possible to add one **TM4ES4** module with the Ethernet port function and two **TM4ES4** modules with the switch function while respecting the maximum number of 3 **TM4** modules .
- On controllers with embedded Ethernet port (TM241CE●● and TM251●●●): it is possible to add 3 modules **TM4ES4** with switch function while respecting the number of 3 **TM4** modules.
- **TM4** communication modules are assembled by simple interlocking on the left-hand side of the controllers and a bus expansion connector is used to distribute data and the power supply.

Description

■ TM4ES4 Ethernet switch module

- 1 Power on LED indicator.
- 2 Bus connector (one on each side).
- 3 4 RJ 45 connectors for Ethernet network, with exchange rate and activity LED.
- 4 Screw terminal for the functional earth (FE) connection.
- 5 Locking clip on \perp symmetrical rail.

■ TM4PDPS1 Profibus DP slave module

- 1 Power on LED indicator.
- 2 Bus connector (one on each side).
- 3 9-way SUB-D connector for connection to the Profibus DP bus.
- 4 Screw terminal for the functional earth (FE) connection.
- 5 Locking clip on \perp symmetrical rail.

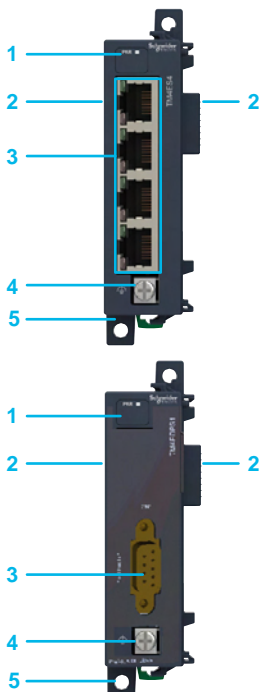

Communication

Modicon TM4 communication modules

For Modicon M241 and Modicon M251 logic controllers



TM4ES4



TM4PDPS1

References

Options for Modicon M241 and M251 logic controllers

| Designation | Description | Reference | Weight kg/ lb |
|-----------------------|---|----------------------|---------------------|
| Communication modules | Multi-port Ethernet interface equipped with four RJ 45 connectors (10/100 Mbps, MDI/MDIX) | TM4ES4 (1) | 0.110/ 0.243 |
| | Slave connection on the Profibus DP bus, equipped with a 9-way SUB-D connector | TM4PDPS1 ▲ | 0.110/ 0.243 |

(1) Can be used as an Ethernet port or as a standalone switch according to controller model and configuration.

Communication

Ethernet Modbus/TCP network

For Modicon M221, M241 and M251 logic controllers and TM4ES4 Ethernet switch module

Presentation

The embedded Ethernet communication ports in each Modicon M221, M241 and M251 logic controller and in the Modicon TM4ES4 communication module optimise integration in factory network architectures.

Modicon M221, M241 and M251 controllers can easily be integrated in typical architectures:

- **machine to devices** (variable speed drives, remote I/O modules, operator dialogue terminals) with the I/O Scanner function
- **machine to machine** with the NGVL function
- **machine to supervision** with the Modbus Client/Server function

Ethernet also brings transparency to the factory, in particular - thanks to the firewall functions - making it possible from any point on the network to safely:

- program, monitor a controller or download an application
- access device parameters (variable speed drives for example)

A simple web browser can be used to access machines anytime anywhere, using a tablet or smartphone, for example, using the web servers embedded in Modicon M241 and M251 controllers.

Safety can be enhanced by the use of VPN modems (see our partner programme).

The Modbus TCP/IP protocol

Modbus has been the industry communication standard since 1979.

During the internet revolution, Modbus was combined with Ethernet Modbus/TCP to form Modbus/TCP, a completely open Ethernet protocol. The development of a connection to Modbus/TCP does not require any proprietary component, nor purchase of a licence.

This protocol can easily be combined with any product supporting a standard TCP/IP communication stack.

The specifications can be downloaded free of charge from the following address: www.modbus.org.

Modbus/TCP, simple and open

- The Modbus application layer is simple and universally familiar with its 9 million installed connections.
- Thousands of manufacturers have already implemented this protocol. Many have already developed a Modbus/TCP connection and numerous products are presently available.
- The simplicity of Modbus/TCP enables any fieldbus device, such as an I/O module, to communicate on Ethernet without the need for a powerful microprocessor or a lot of internal memory.

Modbus/TCP, high performance

Thanks to the simplicity of its protocol and the fast speed of 100 Mbps, the performance of Modbus/TCP is excellent. This type of network can therefore be used in realtime applications such as I/O digitisation.

Modbus/TCP, a standard

- The application protocol is identical on Modbus serial link and Modbus/TCP: messages can be routed from one network to the other without converting the protocol.
- Since Modbus operates on the TCP higher layer, users benefit from IP routing, thus enabling devices located anywhere in the world to communicate without worrying about the distance between them.

Modbus and Modbus/TCP are recognised as a fieldbus by the international standard IEC/EN 61158. They also comply with the "national Chinese standard" managed by ITEI.

Communication

Ethernet Modbus/TCP network

For Modicon M221, M241 and M251 logic controllers and TM4ES4 Ethernet switch module



Preconfigured Web server

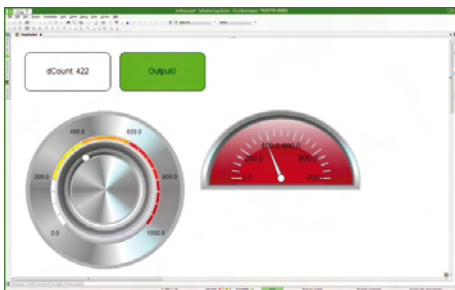

Viewer Web server

Web servers

Preconfigured Web server

Using a simple Internet browser available on PC, smartphone or tablet, this server authorizes the following “ready-to-use” functions:

- With no prior programming
 - Display of the I/O states
 - Controller diagnostics, and of its expansion and communication modules
 - Communication port diagnostics
 - I/O Scanner function diagnostics
 - Maintenance and configuration functions (Ethernet IP, firewall, etc.)
- After configuration
 - Viewing data values
 - Viewing the evolution of those data values over time (oscilloscope function)

Viewer Web server

The SoMachine programming software is used to create customised pages for viewing and monitoring devices. These pages can also be accessed on any mobile device such as a tablet or smartphone with any operating system (iOS, Android, Windows).

Description of Ethernet services

Network Global Variable List (NGVL)

The NGVL protocol allows a controller to share data with other controllers on a local Ethernet network (LAN) or subscribe to data published by other controllers which support the NGVL protocol and thus allowing, for example, synchronisation between control platforms.

I/O Scanner

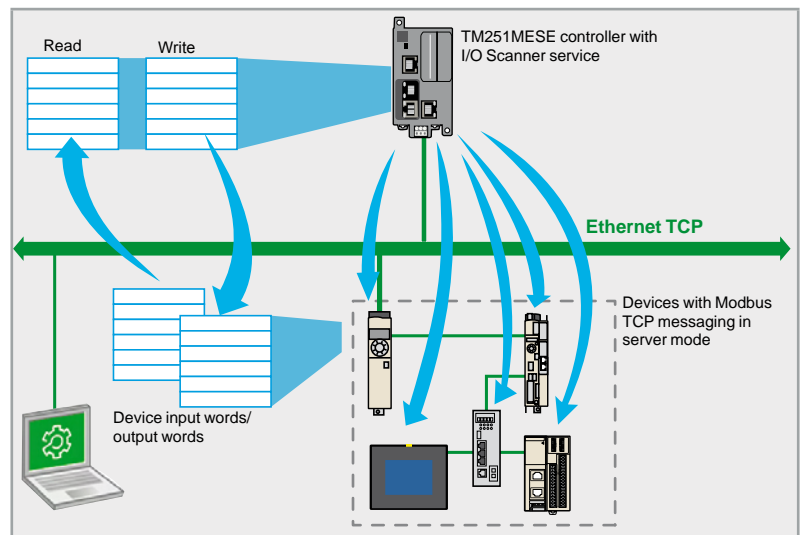

The Modbus TCP I/O Scanner service is used to manage the exchange of remote I/O states on the Ethernet network after a simple configuration operation, with no need for special programming.

I/O Scanner is performed transparently by means of read/write requests in accordance with the Modbus client/server protocol on the TCP profile.

This principle of Scanner via a standard protocol enables a device with the I/O Scanner service to communicate with any device supporting Modbus TCP messaging in server mode (slave Modbus TCP). The M251MESE I/O Scanner system supports up to 64 devices (one Modbus request per device).

Communication

Ethernet Modbus/TCP network

For Modicon M221, M241 and M251 logic controllers and TM4ES4 Ethernet switch module

Description of Ethernet services (continued)

Slave Modbus TCP

This function can be used to create a dedicated I/O table in the controller, which can be accessed via the Modbus TCP protocol and by a controller with the Modbus TCP I/O Scanner function.

Fast Device Replacement (FDR)

This service uses standard address management technologies (BOOTP, DHCP) and the TFTP (Trivial File Transfer Protocol) file management service, in order to simplify maintenance of Ethernet products.

The FDR service is used to replace a device with a new device; the faulty device is detected, reconfigured and automatically rebooted by the system.

Access to files via FTP (File Transfer Protocol)

This service provides access to the controller files from, for example, a PC (FTP client) and is used to exchange files such as application programs, data, etc.

This service can be accessed even if the controller has no application program in its memory.

Dynamic Host Configuration Protocol (DHCP)

This protocol can be used to assign an address to a controller (client DHCP/BOOTP) automatically. This address can be:

- Fixed and determined either in the SoMachine software or included in a post-configuration file
- Assigned by a controller with the DHCP server or BOOTP server function (such as the TM251MESE controller).

SNMP (Simple Network Management Protocol)

From a network management station, the SNMP protocol is used to monitor and control the Ethernet architecture components, meaning problems are diagnosed quickly.

The SNMP protocol is used to access configuration and management objects that are contained in the device MIBs (Management Information Bases).

Modicon M241 and M251 controllers support the "MIB 2 Standard" SNMP network management interface. This interface accesses a first level of network management; it enables the manager to identify the devices making up the architecture and retrieve general information about configuration and operation of the Ethernet Modbus/TCP interfaces.

IP address filter (Whitelisting)

IP addresses that are authorised to access the controller can be loaded in the controller from either an SD card or an FTP client.

Locking communication protocols

Not only SoMachine, NetManage (1), SNMP communication protocols but also Modbus, WEB and FTP servers can be locked individually in the SoMachine software.

(1) The NetManage function can automatically detect which controllers are present on the network. It also offers the option of straightforward connection to any controller present on the network in order to identify it physically by means of a visual or audible message and modify its parameters or manage the resident application.

Transparent Ready class and Functions

| | Logic controllers | | | |
|--|--|----------------------------------|------------|-----------|
| | TM221ME●●● TM221CE●●● | TM241CE●●● TM241C●●● + TM4ES4 | TM251MESCC | TM251MESE |
| Transparent Ready class | A10 | B20 | | |
| Internet protocol version | IP V4 | | | |
| Ethernet services | | | | |
| Programming, downloading, monitoring | | | | |
| Firmware update | – | | | |
| Client and server Modbus TCP | | | | |
| Slave Modbus TCP | | | | |
| Ethernet IP (adapter) | – | | | |
| Data exchange: NVGL and IEC VAR ACCESS | – | | | |
| WEB server | – | | | |
| MIB2 SNMP network management | – | | | |
| Modbus TCP I/O Scanner | – | – | – | |
| FTP file transfer | – | | | |
| Client DHCP dynamic configuration | | | | |
| Server DHCP dynamic configuration | – | – | – | |
| FDR faulty device replacement | – | – | – | |
| SMS, emails | Availability : 4 th quarter 2014 | – | – | – |
| Safety functions | | | | |
| IP address filter (Whitelisting) | – | | | |
| Locking communication protocols | | | | |
| Locking IP address routing | – | – | – | |

function created

Ethernet ports on logic controllers and the communication module

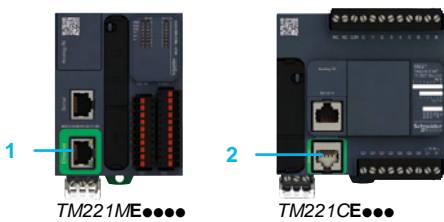

TM221ME●●●●

TM221CE●●●

M221 logic controllers

- 1 On **TM221ME●●●●** controllers: RJ 45 connector for Ethernet network, with exchange rate and activity LED.
- 2 On **TM221CE●●●** controllers: RJ 45 connector for Ethernet network, with exchange rate and activity LED.



TM241CE●●●

M241 logic controllers

- 3 On **TM241CE●●●** controllers: RJ 45 connector for Ethernet network, with exchange rate and activity LED.

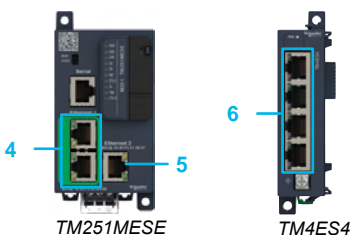

TM251MESE

TM4ES4

M251 logic controllers

- 4 On **TM251MESE** and **TM251MESCC** controllers: 2 connectors connected by an RJ 45 internal switch for “Machine or Factory” Ethernet network, with exchange rate and activity LED.
- 5 On **TM251MESE** controller: RJ 45 connector for “fieldbus” Ethernet 2 network, with exchange rate and activity LED. The Ethernet 2 network can be used with the Modbus TCP I/O Scanner function.

TM4ES4 Ethernet switch communication module

- 6 4 RJ 45 connectors for Ethernet 2 network, with exchange rate and activity LED.

Communication architecture on Ethernet network

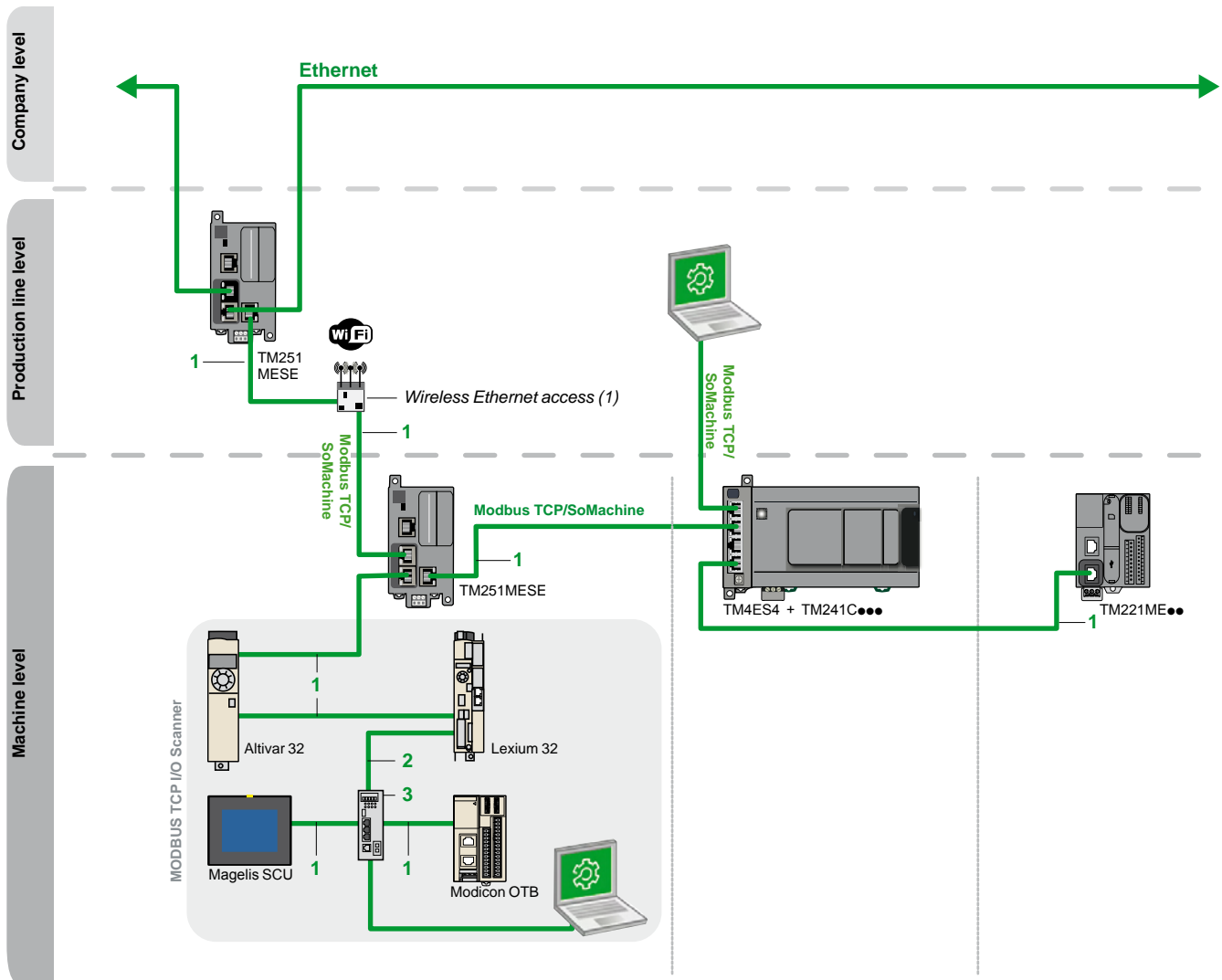

4

NB: The ports on M251 controllers and the TM4ES4 communication module cannot be used to create redundant architectures.

(1) Wireless Ethernet access, see our partner programme.

Items 1, 2 and 3: see references on next page.

Shielded copper connection cables

ConneXium shielded connection cables are available in two versions to meet the requirements of the various current standards and approvals:

■ **EIA/TIA 568 shielded twisted pair cables for CE market**

These cables conform to:

- EIA/TIA-568 standard, category CAT 5E
- IEC 11801/EN 50173-1 standard, class D

Their fire resistance conforms to:

- NF C32-070 standard, class C2
- IEC 322/1 standards
- Low Smoke Zero Halogen (LSZH)

■ **EIA/TIA 568 shielded twisted pair cables for UL market**

These cables are:

- CEC type FT-1
- NEC type CM

A new range of **ConneXium** fully shielded preassembled cables has been specially designed for use in harsh industrial environments. These cables combine a category 5E shielded cable and RJ 45 connectors reinforced with a metal profile.

References

EIA/TIA 568 shielded twisted pair cables for C€ market

| Description | End fittings | Item | Type | Length m/ft | Reference | Weight kg/lb |
|---|--|------|------------|----------------|----------------|-----------------|
| Straight-through copper cables C€ compatible | 2 RJ 45 connectors For connection to terminal devices (DTE) | 1 | standard | 2/6.56 | 490NTW00002 | – |
| | | | | 5/16.40 | 490NTW00005 | – |
| | | | | 12/39.37 | 490NTW00012 | – |
| | | | | 40/131.23 | 490NTW00040 | – |
| | | | | 80/262.47 | 490NTW00080 | – |
| | | 1 | ruggedised | 1/3.28 | TCSECE3M3M1S4 | – |
| | | | | 2/6.56 | TCSECE3M3M2S4 | – |
| | | | | 3/9.84 | TCSECE3M3M3S4 | – |
| | | | | 5/16.40 | TCSECE3M3M5S4 | – |
| | | | | 10/32.81 | TCSECE3M3M10S4 | – |



TCSEC●3M3M●●S4

Shielded twisted pair cables for UL market

| Description | End fittings | Item | Type | Length m/ft | Reference | Weight kg/lb |
|---|--|------|------------|----------------|----------------|-----------------|
| Straight-through copper cables UL compatible | 2 RJ 45 connectors For connection to terminal devices (DTE) | 1 | standard | 2/6.56 | 490NTW00002U | – |
| | | | | 5/16.40 | 490NTW00005U | – |
| | | | | 12/39.37 | 490NTW00012U | – |
| | | | | 40/131.23 | 490NTW00040U | – |
| | | | | 80/262.47 | 490NTW00080U | – |
| | | 1 | ruggedised | 1/3.28 | TCSECU3M3M1S4 | – |
| | | | | 2/6.56 | TCSECU3M3M2S4 | – |
| | | | | 3/9.84 | TCSECU3M3M3S4 | – |
| | | | | 5/16.40 | TCSECU3M3M5S4 | – |
| | | | | 10/32.81 | TCSECU3M3M10S4 | – |

Do it Yourself copper cable and connectors

The **ConneXium** “Do it Yourself” offer consists of 2 connector references (M12 and RJ 45) and 1 cable reference - 300 m (984.252 ft) reel - enabling Ethernet 10/100 Mbps network cables to be made up in situ. The maximum length of cables made up in this way is 80 m (262.467 ft.). They are assembled using only a knife and wire cutters (no special tool is required).

| Description | Characteristics | Item | Length m/ft | Reference | Weight kg/lb |
|---|---|------|----------------|-------------|-----------------|
| Ethernet copper cable 2 shielded twisted pairs 24 AWG | Conforms to the standards and approval listed above | 2 | 300/984.25 | TCSECN300R2 | – |
| RJ 45 connector | Conforms to EIA/TIA-568-D | 2 | – | TCSEK3MDS | – |

ConneXium unmanaged switches, 3, 4 and 5 ports, twisted pair and optical fibre

| Description | Interfaces | Item | Reference | Weight kg/ lb |
|------------------------------|---|------|---------------|---------------------|
| ConneXium unmanaged switches | 3 x 10BASE-T/100BASE-TX ports (copper cable), RJ 45 shielded connectors | 3 | TCSESU033FN0 | 0.113/ 0.249 |
| | ■ 4 x 10BASE-T/100BASE-TX ports (copper cable), RJ 45 shielded connectors ■ 1 x 100BASE-FX port (multimode optical fibre), duplex SC connector | 3 | TCSESU043F1N0 | 0.120/ 0.265 |
| | 5 x 10BASE-T/100BASE-TX ports (copper cable), RJ 45 shielded connectors | 3 | TCSESU053FN0 | 0.113/ 0.249 |

Other wiring components are available, please consult the **ConneXium** offer on our website www.schneider-electric.com.



TCSESU053FN0

Communication

Ethernet Modbus/TCP network
for Modicon M258 logic controller and Modicon LMC058
motion controller, XBTGT/GK with control function,
Altivar IMC drive controller

Ethernet

Ethernet Modbus/TCP or Ethernet IP network architecture

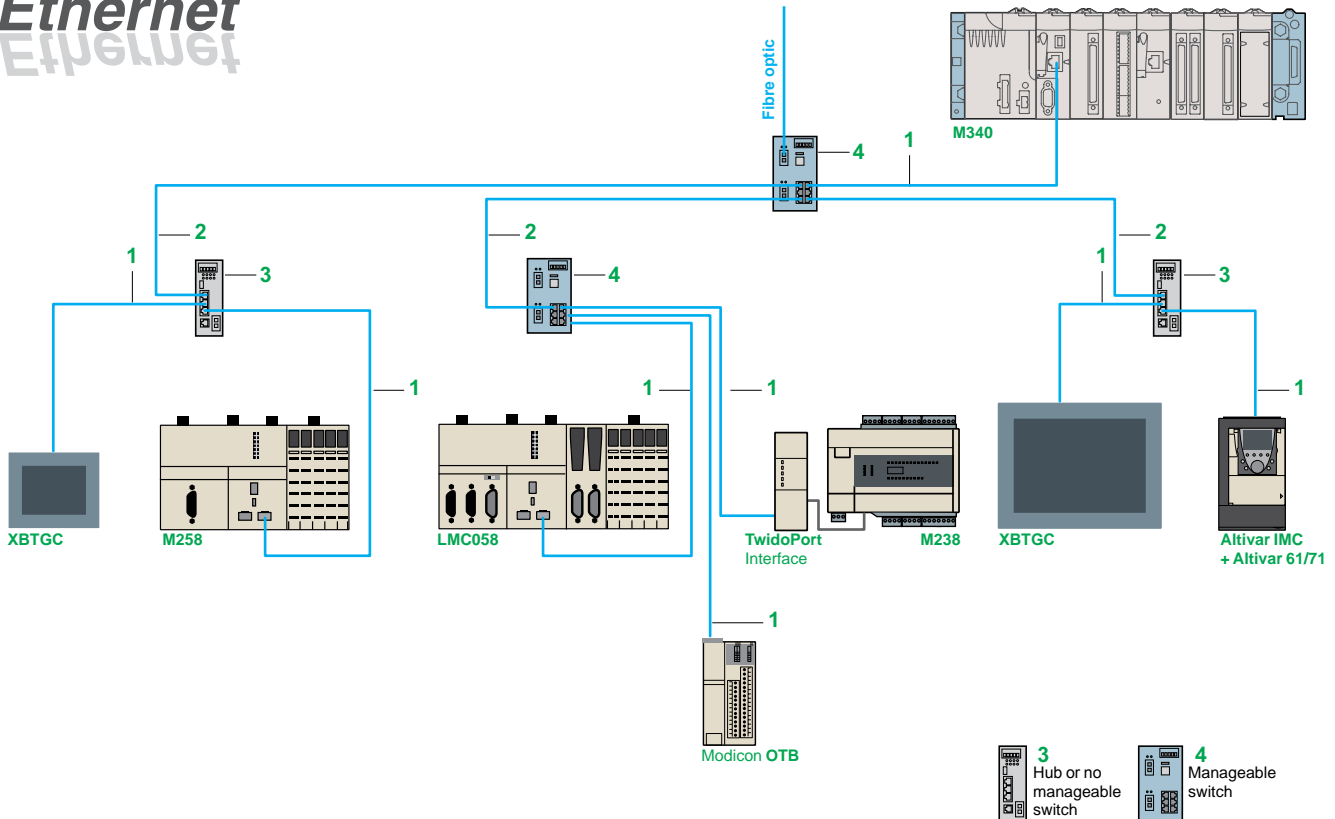

4

References (1)

Shielded copper connection cables

ConneXium shielded copper connection cables are available in two versions to comply with the different standards and approvals in force:

■ Shielded twisted pair copper cables to standard EIA/TIA 568

These cables conform to:

- standard EIA/TIA 568, category CAT 5E,
- standard IEC 11801/EN 50173, class D.

Their flame resistance conforms to:

- NFC 32070# classification C2
- standards IEC 322/1,
- Low Smoke Zero Halogen (LSZH).

■ Shielded twisted pair copper cables, UL and CSA 22.1 approved

These cables conform to:

- standards UL and CSA 22.1.

Their flame resistance conforms to NFPA 70.

“Do It Yourself” cable and connectors

The ConneXium “Do It Yourself” range allows the user to make up Ethernet copper cables on site and to the required length. They are designed for cabling Ethernet 10/100 Mbit/s networks. The maximum length of cables made up in this way is 80 m. They can be assembled quickly using a knife and cutting pliers (no special tools are required).

| Description | Characteristics | Length m/ft | Reference | Weight kg |
|--|---|----------------|--------------------|-----------|
| Ethernet copper cable 2 shielded twisted pairs 24 AWG | Conforming to the above-mentioned standards and approvals | 300/ 984.25 | TCSECN300R2 | – |
| RJ 45 connector | Conforming to EIA/TIA-568-D | – | TCSEK3MDS | – |
| M12 connector | Conforming to IEC 60176-2-101 | – | TCSEK1MDRS | – |

(1) Other versions (fibre optic, switches, ...): please consult our site www.schneider-electric.com

Communication

Ethernet Modbus/TCP network

for Modicon M258 logic controller and Modicon LMC058 motion controller, XBTGT/GK with control function, Altivar IMC drive controller



490 NT●000●●



TCSESU043F1N0



TCSESM043F2C●0



499NMS/NSS25102



TCSESM083F2C●0



TCSESU051F0

References (continued)

Shielded twisted pair cables to standard EIA/TIA568

| Description | Pre-formed at both ends | Item | Length m/ft | Reference | Weight kg/lb |
|------------------|---|------|-------------|-------------|--------------|
| Straight cables | 2 x RJ45 connectors For connection to terminal equipment (DTE) | 1 | 2/6.56 | 490NTW00002 | — |
| | | — | 5/16.40 | 490NTW00005 | — |
| | | — | 12/39.37 | 490NTW00012 | — |
| | | — | 40/131.23 | 490NTW00040 | — |
| | | — | 80/262.47 | 490NTW00080 | — |
| Crossover cables | 2 x RJ45 connectors For connection between hubs, switches and transceivers | 2 | 5/16.40 | 490NTC00005 | — |
| | | — | 12/39.37 | 490NTC00015 | — |
| | | — | 40/131.23 | 490NTC00040 | — |
| | | — | 80/262.47 | 490NTC00080 | — |

Shielded twisted pair cables, UL and CSA 22.1 approved

| Description | Pre-formed at both ends | Item | Length m/ft | Reference | Weight kg/lb |
|------------------|---|------|-------------|--------------|--------------|
| Straight cables | 2 x RJ45 connectors For connection to terminal equipment (DTE) | 1 | 2/6.56 | 490NTW00002U | — |
| | | — | 5/16.40 | 490NTW00005U | — |
| | | — | 12/39.37 | 490NTW00012U | — |
| | | — | 40/131.23 | 490NTW00040U | — |
| | | — | 80/262.47 | 490NTW00080U | — |
| Crossover cables | 2 x RJ45 connectors For connection between hubs, switches and transceivers | 2 | 5/16.40 | 490NTC00005U | — |
| | | — | 40/131.23 | 490NTC00040U | — |
| | | — | 80/262.46 | 490NTC00080U | — |

Shielded twisted pair cable for IP 67 switch

| Description | Pre-formed at both ends | Item | Length m/ft | Reference | Weight kg/lb |
|-----------------|--|------|-------------|----------------|--------------|
| Straight cables | 1 x IP 67 4-way M12 connector and 1 x RJ45 connector | — | 1/3.28 | TCSECL1M3M1S2 | — |
| | | — | 3/9.84 | TCSECL1M3M3S2 | — |
| | | — | 5/16.40 | TCSECL1M3M5S2 | — |
| | | — | 10/32.81 | TCSECL1M3M10S2 | — |
| | | — | 25/82.02 | TCSECL1M3M25S2 | — |
| | | — | 40/131.23 | TCSECL1M3M40S2 | — |

ConneXium hub

| Description | Number of ports | | Item | Reference | Weight kg/lb |
|---|-----------------|-------------|------|-------------|-----------------|
| | Copper cable | Fibre optic | | | |
| Twisted pair hub 10BASE-T copper ports, RJ45 shielded connectors | 4 | — | 3 | 499NEH10410 | 0.530/ 1.168 |

ConneXium switches

| Description | Number of ports | | Item | Manag-eable | Reference | Weight kg/lb |
|--|-----------------|----------------|------|-------------|----------------|-----------------|
| | Copper cable | Fibre optic | | | | |
| Optimized twisted pair switch 10BASE-T/100BASE-TX copper ports, RJ45 shielded connectors 100BASE-FX optic port, SC connectors | 3 | — | 3 | No | TCSESU033FN0 | 0.113/ 0.249 |
| | 4 | 1 | 3 | No | TCSESU043F1N0 | 0.120/ 0.265 |
| | 5 | — | 3 | No | TCSESU053FN0 | 0.113/ 0.249 |
| Twisted pair switches 10BASE-T/100BASE-TX copper ports, RJ45 shielded connectors | 8 | — | 3 | No | 499NES18100 | 0.230/ 0.507 |
| | 8 | — | 4 | Yes | TCSESM083F23F0 | 0.410/ 0.904 |
| Twisted pair and fibre optic switches 10BASE-T/100BASE-TX copper ports, RJ45 shielded connectors. 100BASE-FX optic ports, SC connectors | 3 | 1, multimode | 4 | Yes | TCSESM043F1CU0 | 0.400/ 0.882 |
| | 2 | 2, multimode | 4 | Yes | TCSESM043F2CU0 | 0.400/ 0.882 |
| | 3 | 1, single-mode | 4 | Yes | TCSESM043F1CS0 | 0.400/ 0.882 |
| | 2 | 2, single-mode | 4 | Yes | TCSESM043F2CS0 | 0.400/ 0.882 |
| | 4 | 1, multimode | 3 | No | 499NMS25101 | 0.330/ 0.728 |
| | 3 | 2, multimode | 3 | No | 499NMS25102 | 0.335/ 0.739 |
| | 4 | 1, single-mode | 3 | No | 499NSS25101 | 0.330/ 0.728 |
| | 3 | 2, single-mode | 3 | No | 499NSS25102 | 0.335/ 0.739 |
| | 7 | 1, multimode | 4 | Yes | TCSESM083F1CU0 | 0.410/ 0.904 |
| | 6 | 2, multimode | 4 | Yes | TCSESM083F2CU0 | 0.410/ 0.904 |
| IP 67 twisted pair switch (1) 10BASE-T/100BASE-TX copper ports, shielded M12 connectors (type D) | 5 | — | — | No | TCSESU051F0 | 0.210/ 0.463 |

(1) Require special cables with M12 connectors for their --- 24 V supply: XZCP1●64L●

chapter 5

SoMachine software



All technical information about products listed in this chapter
are available on www.schneider-electric.com

■ **SoMachine software**

- Presentation 5/2
- Characteristics 5/4
- References 5/5

■ **SoMachine Basic software**

- Presentation 5/6
- Function 5/7
- References 5/11

SoMachine software

Simplify machine programming and commissioning



SoMachine software platform

Presentation

SoMachine is the machine builders solution software for developing, configuring, and commissioning the entire machine in a single software environment, including logic, motion control, HMI, and related network automation functions.

SoMachine allows you to program and commission all the elements in Schneider Electric's Flexible and Scalable Control Platform, the comprehensive solution-oriented offer for machine builders, which helps you achieve the optimum control solution for each machine's requirements.

The Flexible and Scalable Control Platforms offer includes:

- Controllers:
 - Modicon logic controllers: M238, M241, M251, and M258
 - Modicon motion controllers: LMC058, LMC078 ▲
 - HMI controllers: Magelis SCU, XBTGC, XBTGT/GK
 - Drive controller: Altivar IMC
- I/O:
 - Modicon modules: TM2, TM3, TM5, and TM7 offers
- HMI:
 - Magelis™ STO/STU Small Panels
 - Magelis™ GH/GK/GT Advanced Panels
 - Magelis™ GTO Optimum Advanced Panels

Scalability

- SoMachine allows a flexible and scalable usage of controllers in the SoMachine context: it is easy to integrate the M221 logic controllers from SoMachine Basic into a SoMachine project.
- The Flexible Control feature allows you to replace a controller with another one, while retaining the logic and the configuration. Several versions of SoMachine can run in parallel in a system to help ensure compatibility.

SoMachine is a professional, intuitive, and open software solution integrating Vijeo-Designer. It also integrates the configuring and commissioning tool for motion control devices. It features the IEC 61131-3 languages, integrated fieldbus configurators, expert diagnostics and debugging, as well as multiple capabilities for maintenance and visualization including web-visualization.

SoMachine integrates tested, validated, documented, and supported expert application libraries dedicated to applications in pumping, packaging, hoisting, and conveying.

SoMachine is a single software environment with:

- One software package
- One project file
- One connection
- One download operation

Visual graphic user interface

Navigation within SoMachine is intuitive and highly visual. Presentation is optimized in such a way that selecting the development stage of the desired project makes the appropriate tools available. The user interface suggests the tasks to be performed throughout the project development cycle so that nothing is overlooked.

The workspace has been streamlined, so that only that which is necessary and relevant to the current task is featured, without any superfluous information.

Learning center

From the home menu, the learning center provides several tools to help you get started with SoMachine. An animated file explains the SoMachine interface and concept in brief. An e-learning section gives you the opportunity to teach yourself about SoMachine and its new features. A third section provides links to several documented examples of simple coding with SoMachine.

An intuitive and efficient online help is also available to answer your questions.

▲ Available Q2 2014.

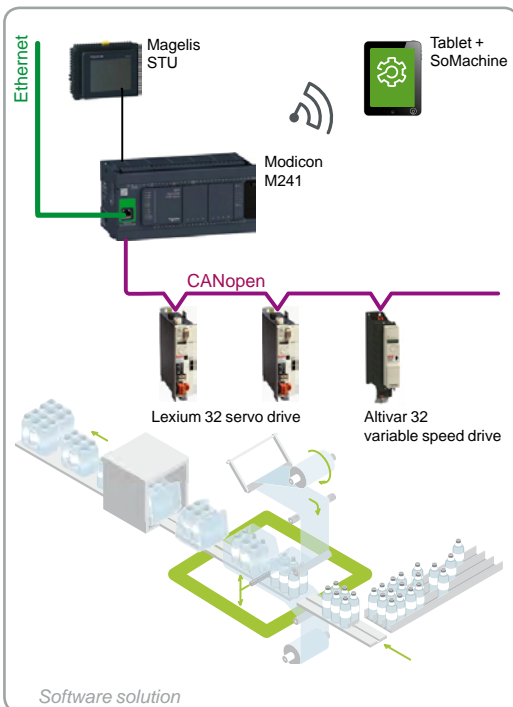

Software solution

SoMachine software

Simplify machine programming and commissioning

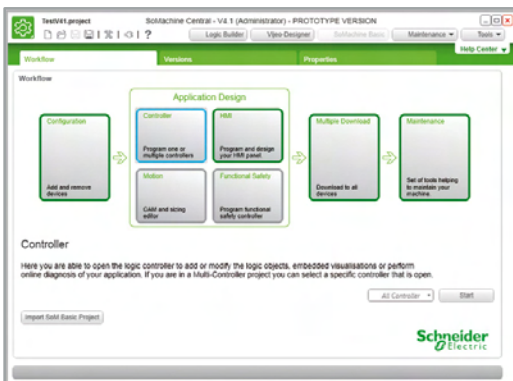

Project management

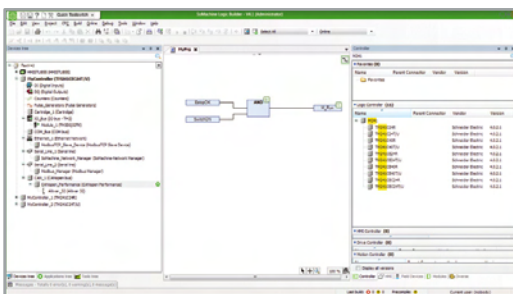

"Catalog"

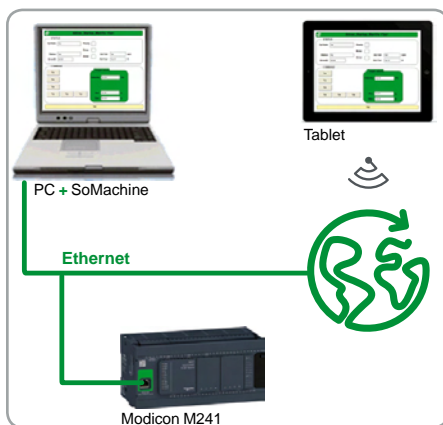

Web visualization

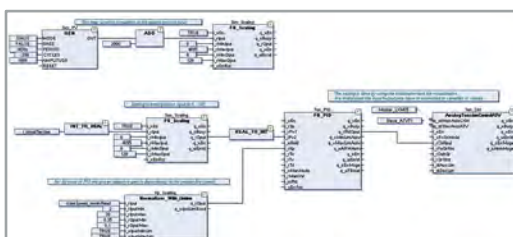

Application Function Blocks

Project management

The software's project management functionality lets you browse through existing projects quickly to gather the relevant information without needing to open each project individually.

There are several ways of creating a new project: using tested, validated, documented architectures, using the examples provided, using an existing project, or starting with an empty project. There is quick access to the most recently used projects.

You can also create a project from a standard project taking advantage of a preconfigured program (task, library, etc.).

Project properties

You can define additional information for each project using simple forms. It is also possible to attach documents and custom or configuration pictures. The software also supports automatic versioning.

Configuration

The user interface allows you to configure devices and architectures in a hierarchical order.

The various elements of the configuration can be easily assembled by selecting from a device "catalog" (controllers, expansion modules, etc.) with a simple drag & drop. The catalog can be searched and filtered as required.

Device templates are available to easily add preconfigured equipment.

Programming and debugging

Programming is an essential step, and the user has to carefully design it to be as efficient as possible. Advanced control and HMI functions cover all the needs of Machine builders in terms of creating the control and visualization systems. Powerful tools allow debugging and functional tests such as simulation, step-by-step execution, breakpoints, and traces.

Documentation

SoMachine allows you to customize and generate a project report for printing:

- Select the items to be included in the report
- Organize the sections
- Define the page layout
- Print the report

Transparency

SoMachine is an FDT (Field Device Tool) container and supports DTM (Device Type Manager) files.

SoMachine manages remote devices via DTM files, providing direct communication with each device. Communication is transparent via SoMachine, the controller, and the fieldbus (Modbus Serial Line, Modbus TCP, CANopen, and CANmotion).

SoMachine also supports FDT/DTM connections directly from the PC to the devices via Modbus Serial Line or Modbus TCP.

Application Function Block (AFB) libraries for dedicated solutions

SoMachine includes application function block libraries for selected machines. Their simple configuration speeds up design, commissioning, installation, and troubleshooting.

These libraries cover the following applications:

- Packaging
- Hoisting
- Conveying
- Pumping

Tested Validated Documented Architectures (TVDA)

SoMachine provides a variety of preset projects with ready-to-use architectures you can adapt to individual requirements. Some of them are generic TVDA based on controller configurations. Others can be dedicated to specific solutions by application-oriented TVDAs.

SoMachine characteristics

| | |
|--|--|
| <p>IEC 61131-3 programming languages</p> | <ul style="list-style-type: none"> ■ IL (Instruction List) ■ LD (Ladder Diagram) ■ SFC (Sequential Function Chart) ■ ST (Structured Text) ■ FBD (Function Block Diagram) + CFC (Continuous Function Chart) |
| <p>Controller programming services</p> | <ul style="list-style-type: none"> ■ Multi-tasking: Mast, Fast, Event ■ Functions (Func) and function blocks (FBs) ■ Data Unit Type (DUTs) ■ Online changes ■ Watch windows ■ Graphical monitoring of variables (trace) ■ Breakpoints, step-by-step execution ■ Simulation ■ Visualization for application and machine setup |
| <p>HMI-based services</p> | <ul style="list-style-type: none"> ■ Graphics libraries containing more than 4,000 2D and 3D objects ■ Simple drawing objects (points, lines, rectangles, ellipses, etc.) ■ Preconfigured objects (button, switch, bar graph, etc.) ■ Recipes (32 groups of 256 recipes with max. 1024 ingredients) ■ Action tables ■ Alarms ■ Printing ■ Java scripts ■ Multimedia file support: wav, png, jpg, emf, bmp ■ Variable trending |
| <p>Motion services</p> | <ul style="list-style-type: none"> ■ Configuration and commissioning of embedded devices ■ CAM profile editor ■ Sample application trace ■ Motion and drive function block libraries for variable speed drives, servo drives, and stepper drives ■ Visualization screens ■ Logical encoder |
| <p>Global services</p> | <ul style="list-style-type: none"> ■ User access and profile ■ Project documentation printing ■ Project comparison (control) ■ Variable sharing based on publish/subscribe mechanism ■ Library version management ■ Machine energy efficiency monitoring |
| <p>Integrated fieldbus configurators</p> | <ul style="list-style-type: none"> ■ Control network: <ul style="list-style-type: none"> □ Modbus Serial Line □ Modbus TCP □ Modbus TCP I/O Scanner ■ Fieldbus: <ul style="list-style-type: none"> □ CANopen □ CANmotion □ sercos III ■ Connectivity: <ul style="list-style-type: none"> □ Profibus-DP □ Ethernet IP ■ Web Visualization: Display the SoMachine controller visualization screens in a web browser |
| <p>Expert and solutions libraries</p> | <ul style="list-style-type: none"> ■ PLCopen function blocks for motion control <ul style="list-style-type: none"> □ Example: MC_MoveAbsolute, MC_CamIn, ServoDrive, etc. ■ Packaging function blocks <ul style="list-style-type: none"> □ Example: Analog film tension control, rotary knife, lateral film position control, etc. ■ Conveying function blocks <ul style="list-style-type: none"> □ Example: tracking, turntable, conveyor, etc. ■ Hoisting functions <ul style="list-style-type: none"> □ Hoisting function blocks: anti-sway, anti-crab, hoisting position synchronization, etc. □ Application template for industrial crane ■ Pumping application <ul style="list-style-type: none"> □ Pumping function blocks: cavitation protection, friction loss, PID, stage/destage functions, etc. □ Application template for booster ■ Material processing application <ul style="list-style-type: none"> □ Application templates ■ Energy efficiency library |
| <p>Tools</p> | <ul style="list-style-type: none"> ■ Controller assistant <ul style="list-style-type: none"> □ Manage the firmware and application without opening SoMachine □ Create images and backup of the controller ■ Software configuration manager <ul style="list-style-type: none"> □ Manage the installed versions and components of SoMachine ■ License manager <ul style="list-style-type: none"> □ Activate and manage licenses for all Schneider Electric licensed products □ Support registration and license transfer ■ Schneider Electric Software Update (SESU) <ul style="list-style-type: none"> □ Online notification of all available updates and news about the installed Schneider Electric software products □ Download and install updates, patches, and extensions from the web |

SoMachine software

Simplify machine programming and commissioning

Product offer

SoMachine software is delivered on a DVD whose features are available for a 21 day trial. Afterwards a license is required to continue to benefit from SoMachine.

- SoMachine is available in 8 languages: English, French, German, Italian, Portuguese, Simplified Chinese, Spanish, and Turkish
- Operating systems for engineering PC: Windows XP Professional, Windows 7 Professional 32-bit/64-bit
- Documentation is supplied in electronic format: complete online help with complementary documentation in pdf version

References

SoMachine software

| Supported controllers | Reference | |
|---|---|--------------------------------------|
| | DVD (1) | License (2) / number & type |
| Modicon M238, Modicon M241, Modicon M251, Modicon M258, Modicon LMC058, Modicon LMC078 ▲, Magelis SCU, XBTGC, XBTGT/GK, Altivar IMC | SOMNACS41 + Trial V4.1 license (21 days) | SOMNACCZXSPAZZ / 1 (Single) |
| | | SOMNACCZXTPAZZ / 10 (Team) |
| | | SOMNACCZXEPAZZ / 100 (Entity) |

Specific application libraries for SoMachine software

| Supported controllers | Application Expert libraries | License | Reference |
|---|------------------------------|---------|-----------------------|
| Modicon M238, Modicon M241, Modicon M251, Modicon M258, Modicon LMC058, Modicon LMC078 ▲, Magelis SCU, XBTGC, XBTGT/GK, Altivar IMC | Hoisting | Single | SOMAAECZXSPAZZ |
| | | Team | SOMAAECZXTPAZZ |

License updating from V3.0 and V3.1 to V4.1

| Supported controllers | SoMachine reference (V3.0/V3.1) | Reference update to SoMachine V4.1 | |
|---|---------------------------------|------------------------------------|----------------|
| Modicon M238, Modicon M258, Modicon LMC058, Magelis SCU, XBTGC, XBTGT/GK, Altivar IMC | MSDCHNLMUA (Single) | SOMNADCZXSPAZZ | Single license |
| | MSDCHNLMTA (Team) | SOMNADCZXTPAZZ | Team license |
| | MSDCHNLMFA (Facility) | SOMNADCZXEPAZZ | Entity license |
| Each controller for Solution (controller Type S) | MSDCHLLMUV3●S0/ MSDCHLLMTV3●S0 | SOMNSDCZXTPAZZ | – |

SoMachine software compatibility with hardware control platforms

| Controller type | SoMachine software version |
|--|------------------------------------|
| Modicon M238, XBTGC | ≥ V1.0 |
| Modicon M258 | ≥ V2.0 |
| Modicon LMC058, Modicon TM5 CANopen Interface, Modicon TM7 CANopen Interface, Drive controller Altivar IMC | ≥ V3.0 |
| Magelis SCU | ≥ V3.1 (+ Vijeo Designer V6.1 SP3) |
| Modicon M241, Modicon M251 | ≥ V4.1 |

(1) The DVD is mandatory and delivered with a trial license.

(2) One of the 3 types of license is mandatory.

▲ Available Q2 2014.

SoMachine Basic programming software

For Modicon M221 and M221 Book logic controllers

Compatibility of offers

SoMachine Basic programming software

- > Modicon M221 logic controllers
- > Modicon M221 Book logic controllers
- > Modicon TM3 expansion modules
- > Modicon TM2 expansion modules

Presentation

SoMachine Basic programming software is a user-friendly tool designed to develop projects on Modicon M221 or Modicon M221 Book logic controllers. It can convert applications created on TwidoSuite and TwidoSoft.

- SoMachine Basic is organized according to the project development cycle: navigation of the software is easy and intuitive.
- SoMachine Basic offers a modern interface, so that getting started is:
 - User-friendly and fast: The simplified interface helps you find the information you need in two or three clicks maximum
 - Efficient, due to functions available



SoMachine Basic software

Connecting a PC to the controller

There are several ways of connecting a PC to controllers during the programming, debugging and maintenance phases.

■ Link via connection cables

The PC is connected to the M221 controllers via the USB-B port, using cable **TCSXCNAMUM3P** (mini-USB to USB).

■ Link via modem ▲

Modems can reduce the frequency of on-site visits for certain maintenance operations.

- Modem **SR2MOD03** connected to the M221 controller must be declared in the hardware configuration. It will be initialized by the controller automatically (Hayes initialization string).
- At the PC end, the SoMachine Basic software will associate a special modem connection that will be memorized in the project (including the telephone number to use).

■ Ethernet network link

With their integral Ethernet port, logic controllers **TM221●●E●●** can be connected to a PC using the Ethernet network and the Modbus TCP/IP protocol.

■ Bluetooth® wireless link

The Bluetooth® wireless link enables complete freedom of movement within a radius of 10 m around the controller.

Schneider Electric offers Bluetooth® wireless adaptors both for the controller side and PC side.

SoMachine Basic programming software

For Modicon M221 and M221 Book logic controllers
Navigation, management, properties, configuration

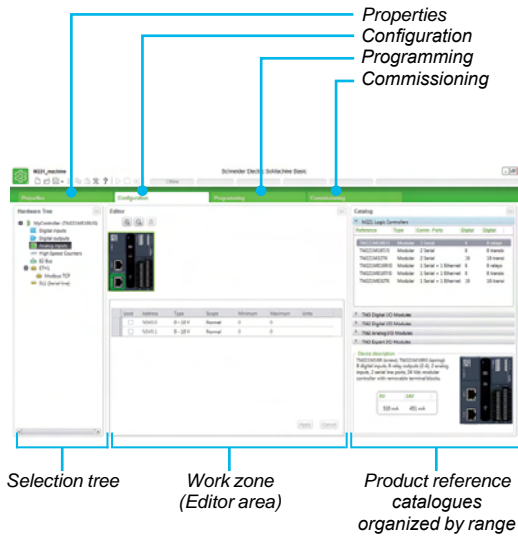

Functions

Navigation

SoMachine Basic offers intuitive and visual navigation.

- The presentation is optimized for selecting the development cycle stage of the project (configuration, programming, commissioning, etc.).
- Each screen is divided into two zones:
 - A selection tree
 - A streamlined workspace to carry out what is necessary and relevant to the current task, without any superfluous information.

Project management

The Project management function is used to:

- Create a new project
- Open a project from the PC (hard disk, CD-ROM, USB key, etc.)
- Retrieve a project from an M221 logic controller
- Open a Twido project, with automatic conversion
- Create a new project based on an existing project template

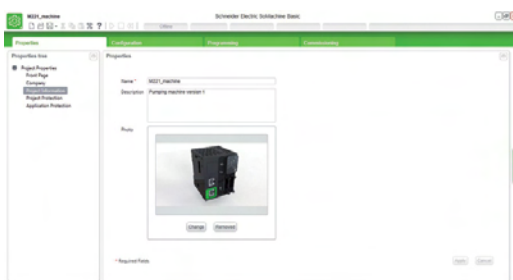

Properties

Properties

Screens enabling entry of identification data for a new project, such as:

- Details of the project creator
- Details of their company
- Information relating to the project
- Project protection information
- Application protection information

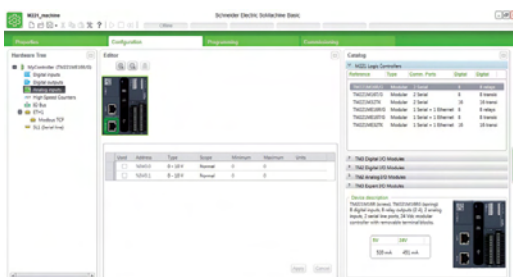

Configuration

Configuration

Configuration allows:

- Creating the hardware configuration corresponding to the application using "catalog" selection:
 - The logic controller (Modicon M221)
 - The I/O expansion modules (Modicon TM2, Modicon TM3)
 - The standard and application cartridges.

A graphic editor enables easy assembly of the various elements using simple drag & drop.

- And configuring all the hardware functions selected for the application:
 - Discrete, analog I/O
 - High Speed Counters inputs
 - Pulse Generator outputs:
 - Pulse Width Modulation (PWM)
 - Pulse generator (PLS)
 - Pulse Train Output (PTO) ▲
 - And the communication ports (Ethernet, serial link)

SoMachine Basic programming software

For Modicon M221 and M221 Book logic controllers
Programming, commissioning, documentation

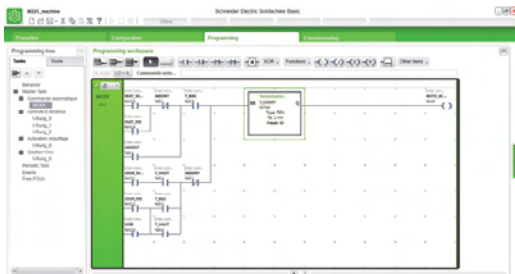

Programming

Functions

Programming

- The program is organized in POU (Program Organization Units) or sections. These sections consist of RUNG (networks) to simplify both reading and navigation within the program.
- The POU are associated with various tasks of the application: master, periodic, events. They can be programmed in:
 - Instruction List (IL) language
 - LADDER (LD) language
- The Rungs define all the connectable elements in the application.
- The LADDER editor provides intuitive and high performance programming:
 - Drag & drop operation
 - Choice of keyboard shortcuts and toolbar according to the user profile
 - List of Rung templates available to assist with the programming of high-level functions
 - Assistance for connection of LADDER elements when creating networks
 - Easy linking of variables to the LADDER elements
 - Context-sensitive online help ▲
 - Project backup, even if the LADDER networks are not complete
 - Automatic analysis and compilation
- Modification online and in Run mode: This mode allows the program of the connected controller to be modified.
- Animation tables.
- Search and replace function.

Commissioning

Tasks that are available and can be carried out during commissioning.

- Connection:
 - Automatic discovery of the controller connected to the PC, according to the type of connection port: USB, Ethernet, Bluetooth®
 - Transfer of application between PC and controller
- Firmware update of the controllers.
- Backup and restoration of all the controller data:
 - Application ▲
 - Firmware ▲
 - Memory area
 - SD memory card management ▲
- Controller information.
- Real-time clock management.

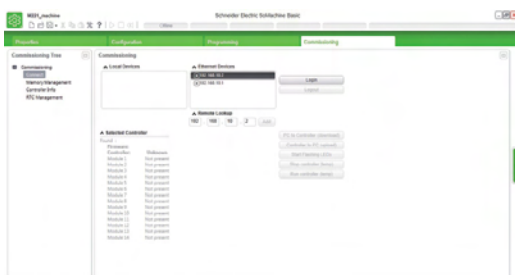

Commissioning

▲ Availability: 2nd quarter 2014.

SoMachine Basic programming software

For Modicon M221 and M221 Book logic controllers
Counting

Functions

Counter function

SoMachine Basic provides two counting software functions for M221 logic controllers.

■ High Speed Counting HSC

The counter is accessed via the 32-bit %HSCi function block. It is programmed for execution of one of the following functions:

- Up/Down counter
- Bi-phase Up/Down counter
- Frequency meter

The pulses to be counted can come from an incremental encoder or proximity sensors (upcounting/downcounting) connected to fast inputs of the M221 logic controller.

■ Fast Counting FC

The 16-bit %FCi fast counter enables upcounting or downcounting of pulses (rising edge) on the fast inputs of the M221 logic controller.

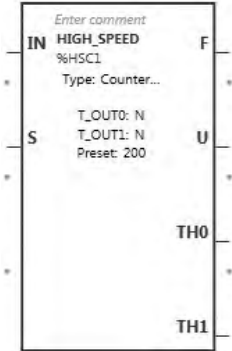

High speed counting HSC



Fast counting FC

SoMachine Basic programming software

For Modicon M221 and M221 Book logic controllers
Position control, event processing, process control (PID)

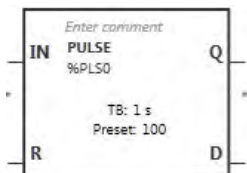

PLS function

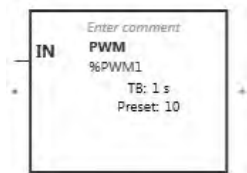

PWM function

Functions

Position control

SoMachine Basic provides three positioning software functions for the M221 logic controllers. For example, they can be used for stepper motors.

■ PLS function

The PLS function block generates fixed ratio pulses. In some cases, the frequency can be fixed and in others it is variable (as in control of slopes when driving a stepper motor). The %PLS function block can be programmed to generate a specific number of pulses.

The %PLS function blocks are assigned to the %Q0.0 or %Q0.1 outputs of the M221 controllers.

The pulse generator signal has a variable period, but with a constant duty cycle which establishes an ON to OFF ratio of 50% of the period.

■ PWM function

The PWM function block generates pulses of fixed frequency, with a variable ON to OFF ratio for the output signal. The ON to OFF duration ratio is a dynamic variable called %PWM.R, with a range from 1% to 100%.

The PWM function blocks are assigned to the %Q0.0 or %Q0.1 outputs on a controller.

The %PWM function block, defined by the user, generates a signal on output %Q0.0 or %Q0.1 of the M221 controller.

■ PTO function ▲

The PTO function enables position control by pulse train - pulse/direction (P/D) or CW/CCW signals, depending on the type of servo drive.

These pulses are generated on outputs %Q0.0 and %Q0.1 of the Modicon M221 logic controller.

Event processing

Event management by the application.

- Source types:
 - Events on embedded inputs
 - Threshold events on the high speed counter (HSC)
 - Periodic event (Timer)
- Each event executes a single subroutine of the program.

Process control (PID)

- 14 PID programming loops.
- Auto-tuning algorithm.
- Analog/PWM output.
- Linear conversion of measurement input.
- 2 alarm levels (high and low) on the measurement.
- Control output limits.
- Direct and Inverse action.

SoMachine Basic programming software

For Modicon M221 and M221 Book logic controllers



SoMachine Basic software

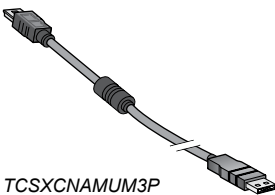

TCSXCNAMUM3P

References

SoMachine Basic software

- SoMachine Basic software runs on the following configurations:
 - Microsoft Windows® XP 32 and 64-bit (Service Pack 3), Microsoft Windows® 7 32 and 64-bit and Microsoft Windows® 8
 - 1 GHz Premium type processor, 1 GB hard disk and 1 GB RAM minimum
 - Minimum screen resolution of 1280 x 800 pixels recommended
- The software product is available on :
 - Our website www.schneider-electric.com
 - CD (see below).

| Description | <input type="checkbox"/> Programming languages <input type="checkbox"/> User languages | Version/ support | Reference | Weight kg/ lb |
|------------------------|--|---------------------|-------------------|---------------------|
| SoMachine Basic | <input type="checkbox"/> Instruction List (IL) language, LADDER (LD) language <input type="checkbox"/> Languages available: English, French, German, Italian, Brazilian Portuguese, Simplified Chinese, Spanish and Turkish | V1.0/ CD | SOMBASAP10 | — |

Cable for connecting a PC to the M221 and M221 Book logic controllers

| Description | For use | | Length m/ft | Reference | Weight kg/ lb |
|--------------------------|---|---|----------------|---------------------|---------------------|
| | From | To | | | |
| Programming cable | Type A USB port of programming and firmware update PC | Mini-B USB port of M221 and M221 Book controllers | 3/9.84 | TCSXCNAMUM3P | 0.065/ 0.143 |

Link via modem

please refer to our website www.schneider-electric.com

Bluetooth® wireless link

please refer to our website www.schneider-electric.com

chapter 6

Machine safety



Why safety?

Human life is the most important value in a company!

Schneider Electric helps protect people and improve your productivity



Functional safety

Simplifying your work to reach your required performance level and SIL

Due to directives and standards as guidelines and our certified safety chain solutions



All technical information about products listed in this chapter are available on www.schneider-electric.com

■ **General presentation**

- How can you improve productivity while simplifying machine safety? 6/4 to 6/7
- Save cost and time with our offer powered by Preventa technology. 6/6 and 6/7

■ **Preventa safety modules**

Selection guide6/8 to 6/13

■ **Preventa safety controllers**

Selection guide6/14 and 6/15

■ **Preventa safety PLCs**

Selection guide6/16 and 6/17

Machine safety

How can you improve productivity while simplifying machine safety?

How can you improve productivity while simplifying machine safety?



Approved

- > Safety chain solutions to achieve the safety level required



Machine Safety Expertise and Co-design

- > Worldwide support and assistance with a local engineers to help you implement machine safety solutions that meet or exceed the latest legislation and compliance with new functional machine safety standards

6



Be confident by using certified safety chain solutions provided by an automation leader

- > Save cost by avoiding external safety experts engineering
- > Reduce design time by our examples of calculation of the safety level for each safety function

Using our certified “Safety chain solutions”. They can help you reduce your machine design time and simplify the determination of safety integrity (SIL) and performance (PL) levels

The concept:

- > Provides you certified safety solutions based upon the most common safety functions required on and around a machine. The safety chain solutions enable you to save time and costs when designing and manufacturing your machine in accordance with the European Machinery Directive

Each solution comes with:

- > Bill of materials and the system description file
- > Safety conceptual principle diagram
- > Layout of solution indicating performance level (PL) and safety integrity level (SIL)
- > Example description of the PL and SIL calculation for the safety function
- > Sistema Library file with corresponding solution
- > TÜV certification

Safety chain solutions



Emergency Stop with Embedded Safety Module

- > Emergency Stop Pushbutton / Contactor
- > Cat.3 PL d, SIL 2 / Stop Category 0

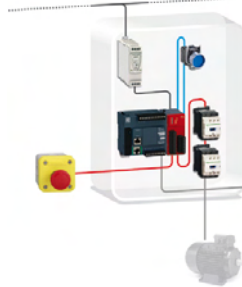

Emergency Stop with Embedded Safety Module

- > Emergency Stop Pushbutton / Contactor
- > Cat.4 PL e, SIL 3 / Stop Category 0

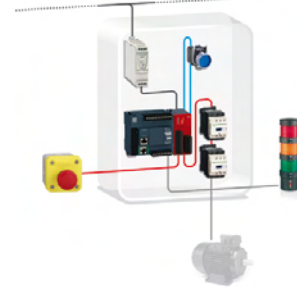

Emergency Stop with Embedded Safety PLC

- > Emergency Stop Push Button / PacDrive 3 Drive
- > Cat.4 PL e, SIL 3 / Stop Category 0

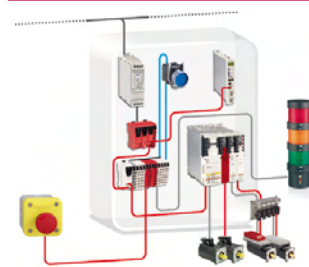

Guard Monitoring with Safety Module

- > Limit switch / Contactor
- > Cat.3 PL d, SIL 2 / Stop Category 0

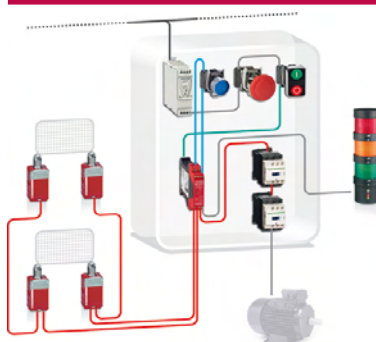

Guard Monitoring with Safety Module

- > Coded Magnetic Switch / Variable Speed Drive
- > Cat.4 PL e, SIL 3 / Stop Category 1

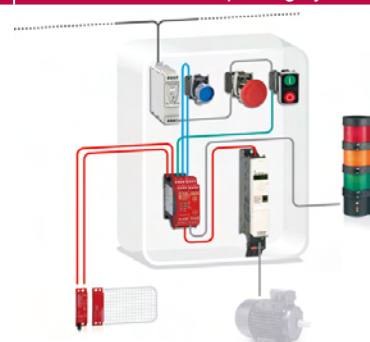

Machine safety

How can you improve productivity while simplifying machine safety?

Safety chain solutions



Guard Monitoring with Safety Module
 > Guard switch with lock / Variable Speed Drive
 > Cat.3 PL d, SIL 2 / Stop Category 1

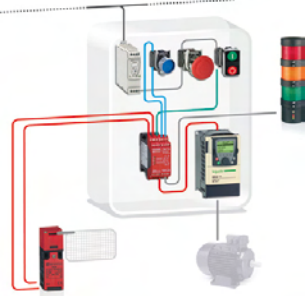

Guard Monitoring with Safety Module
 > Coded Magnetic Switch / Servo Drive
 > Cat.3 PL e, SIL 3 / Stop Category 1

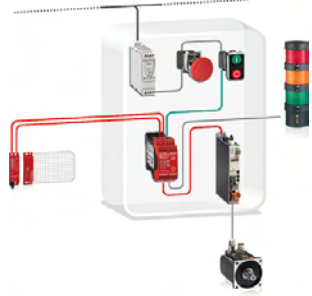

Guard Monitoring with Safety Module
 > Guard switch with lock / Contactor
 > Cat.4 PL e, SIL 3 / Stop Category 0

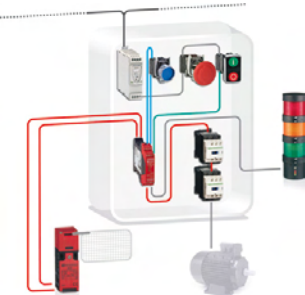

Guard Monitoring with Safety Module
 > Coded Magnetic Switch / Contactor
 > Cat.4 PL e, SIL 3 / Stop Category 0

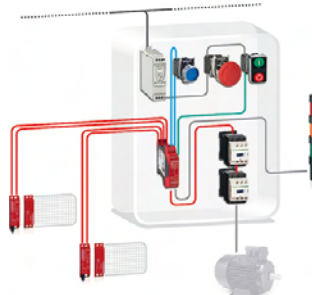

Guard Monitoring with Embedded Safety Module
 > Guard switch with lock / Contactor
 > Cat.4 PL e, SIL 3 / Stop Category 0

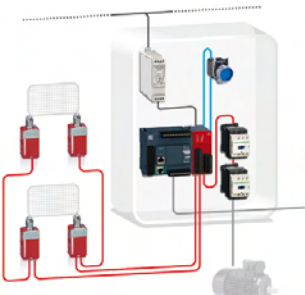

Guard Monitoring with Safety Controller
 > Limit Switch / Contactor
 > Cat.4 PL e, SIL 3 / Stop Category 0

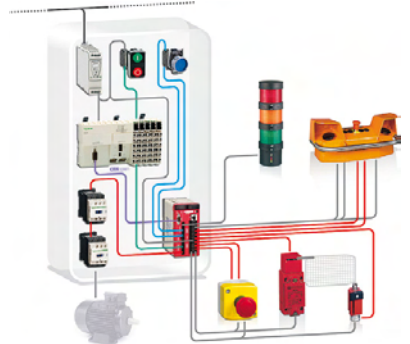

Guard Monitoring with Embedded Safety PLC
 > Guard Switch with lock/ PacDrive 3 Drive
 > Cat.4 PL e, SIL 3 / Stop Category 1

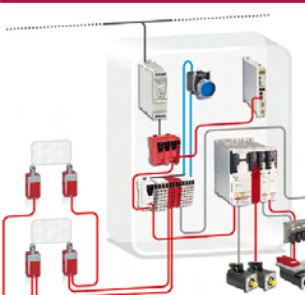

6

Machine safety

How can you improve productivity while simplifying machine safety?

How can you improve productivity while simplifying machine safety?

Safety chain solutions



Guard monitoring with Embedded Safety Servo Drive

- > Coded Magnetic Switch / Embedded Safety Servo Drive
- > Cat.4 PL e, SIL 3 / Stop Category 2

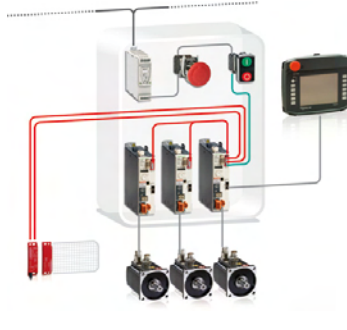

Guard monitoring with Well Tried Components

- > Limit Switch / Motor Starter
- > Cat.3 PL c, SIL 1 / Stop Category 0

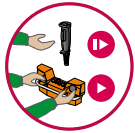
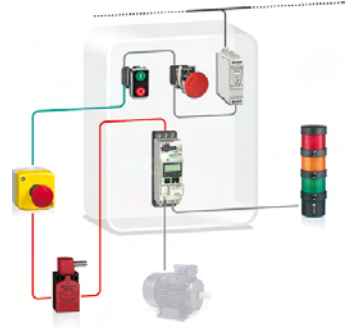

Enabling movement with Safety Controller

- > Two Hand Control Station / Contactor
- > Cat.4 PL e, SIL 3 / Stop Category 0

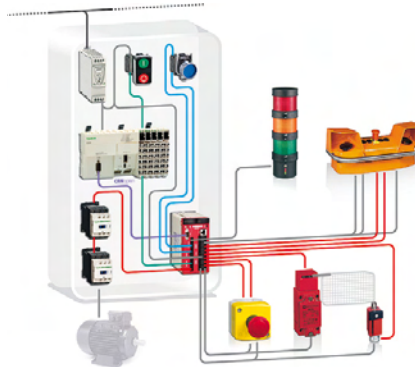

Speed Monitoring with Safety Module

- > Remanent Voltage detection and limit switch and Guard switch with lock / Contactor
- > Cat.4 PL e, SIL 3 / Stop Category 0

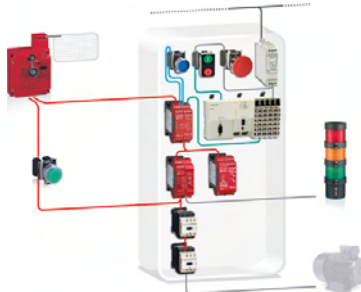

Speed Monitoring with Embedded Safety PLC

- > Selector Switch / PacDrive 3 Drive
- > Cat.4 PL e, SIL 3 / Safe Limited Speed

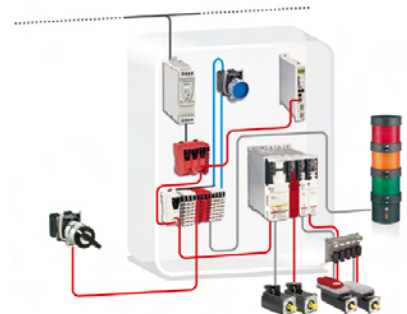

Machine safety

How can you improve productivity while simplifying machine safety?

Safety chain solutions

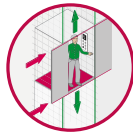

Position Monitoring with Embedded Safety PLC

- > Limit Switch / PacDrive 3 Drive
- > Cat.4 PL e, SIL 3 / Stop Category 2

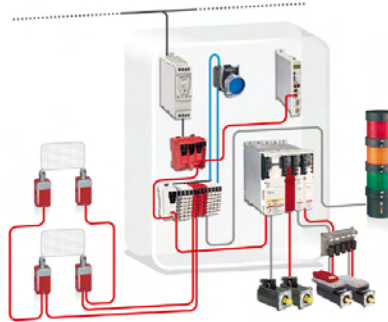

Perimeter Guarding with Safety Module

- > Safety Mat / Contactor
- > Cat.3 PL d, SIL 2 / Stop Category 0

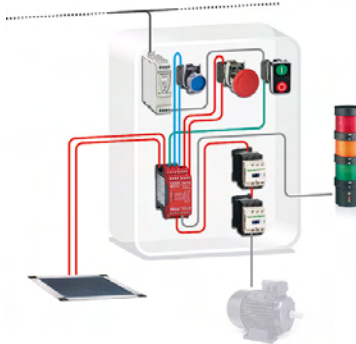

Perimeter Guarding with Safety Module

- > Single Beam Light curtains / Contactor
- > Cat.3 PL c, SIL 1 / Stop Category 0

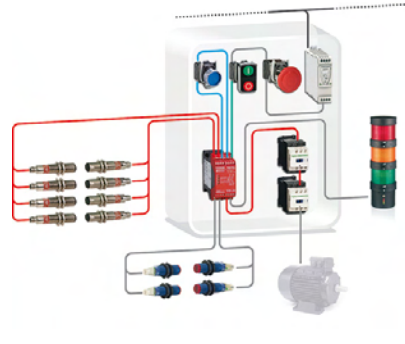

Perimeter Guarding with Embedded Safety Module

- > Light curtain / Contactor
- > Cat.4 PL e, SIL 3 / Stop Category 0

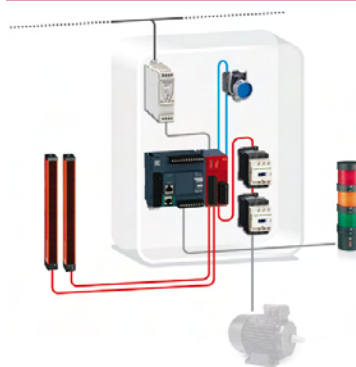

Perimeter Guarding with Embedded Safety Module

- > Light curtain / Variable Speed Drive
- > Cat.3 PL d, SIL 2 / Stop Category 1

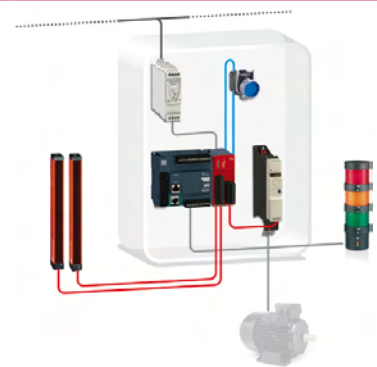

6

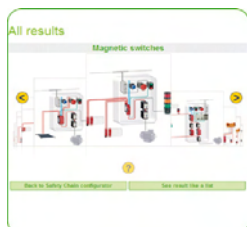

Don't wait more to implement easily the new functional standards, we guide you step by step on <http://www.schneider-electric.com>

- > download our Machine Safety guide
- > select the right safety chain with our online selection tools
- > evaluate the safety of your machine with Software-Assistent SISTEMA & download the Schneider Electric Preventa SISTEMA library

Machine safety

How can you improve productivity while simplifying machine safety?

Save cost and time with our offer powered by Preventa technology

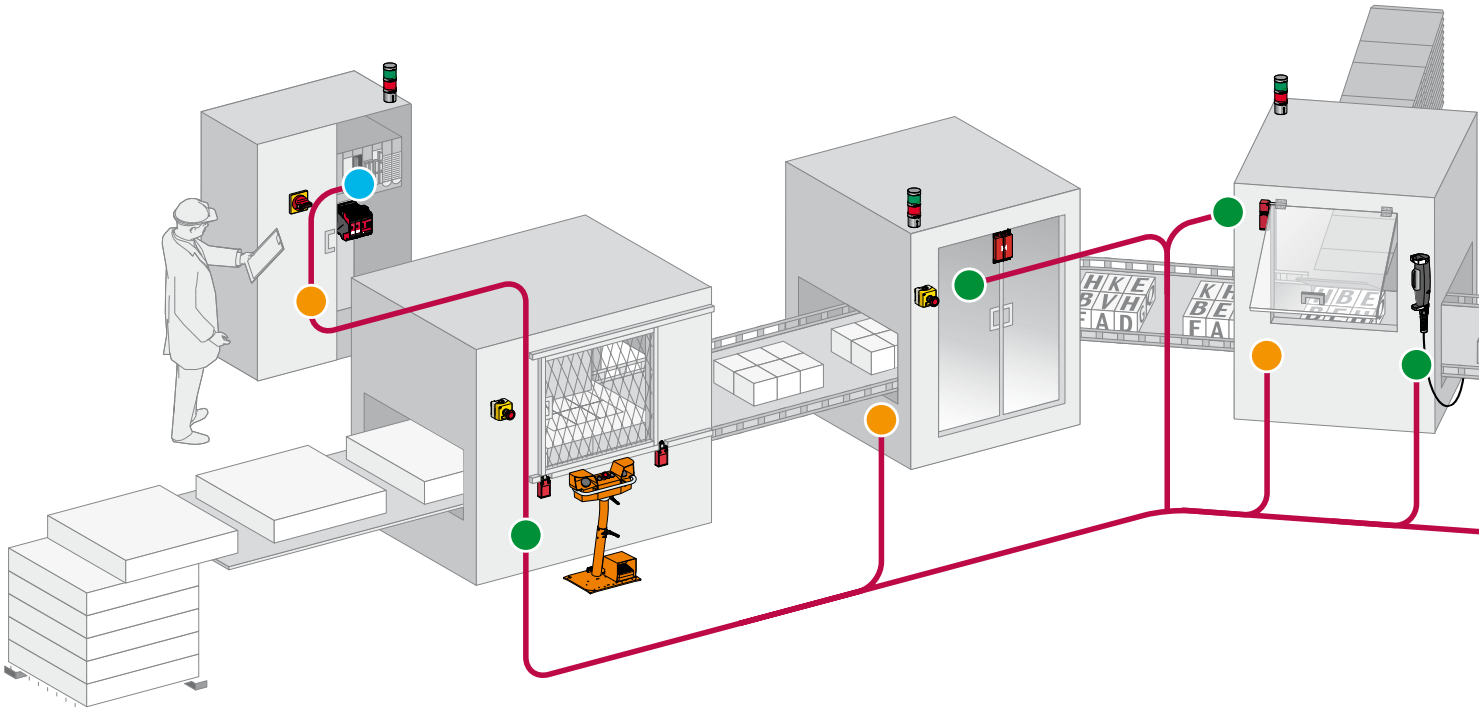

6

Safe signal transmission

Acquire the information:

- > Protective guard devices used as part of safeguarding systems to control the access under specific conditions of reduced risk
- > Light curtains to detect approach to dangerous and limited areas
- > Two hand control stations and enabling switches starting and enabling of dangerous movements
- > Generic protective measures - Emergency stop

Monitor and processing:

- > Safety modules: manage one safety function, monitoring inputs from safety devices and manages the outputs to contactors and drives
- > Safety configurable controllers: stand alone or modular safety controller capable of managing multiple safety functions simultaneously
- > Safety PLCs: programmable electronic systems to carry out safety or non-safety related tasks for machinery and equipment



Protective guard devices



Light curtains



Two hand control stations and enabling switches



Tripwire switch Emergency stop



Safety modules



Safety Controller



Safety PLCs

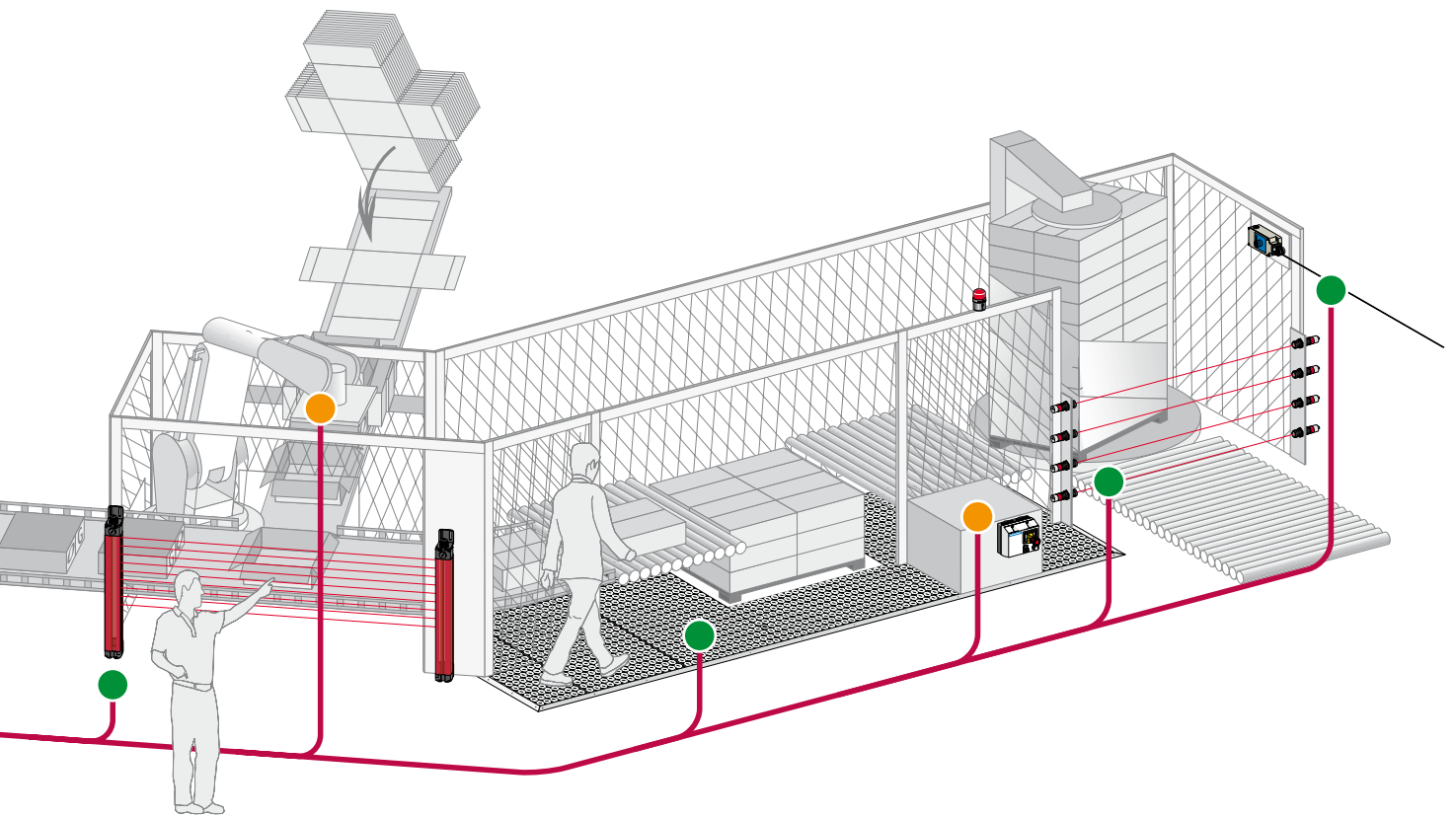

Stop the machine:

- > Contactors to cut-off the electrical power supply to the motors with mechanically linked mirror auxiliary contacts integrated for the feedback loop diagnosis used by the Safety modules, Controllers and PLCs
- > Variable speed drives and Servo drives provide controlled stopping of the machine by using embedded safety functions
- > Rotary switch disconnectors: for equipment isolation from the electrical supply and for emergency stop by direct interruption of the power supply



Variable speed drives



Servo drives



Contactors



Rotary switch disconnectors

Machine safety

Preventa safety modules

Applications

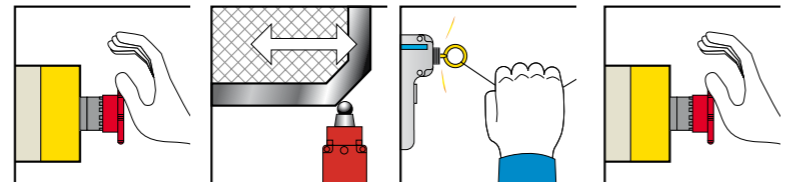

Modules

For Emergency stop and switch monitoring

For Emergency stop and protective guard applications



| | | | | |
|--|---|--|--|--|
| Maximum achievable safety level | PLe/Category 4 conforming to EN/ISO 13849-1, SILCL3 conforming to EN/IEC 61508 and EN/IEC 62061 | | | |
| Conformity to standards | EN/IEC 60204-1, EN 1088/ISO 14119, EN/ISO 13850, EN/IEC 60947-1, EN/IEC 60947-5-1 | | | |
| Product certifications | UL, CSA, TÜV | | | |

| | | | | |
|---------------------------|---|--|--|--|
| Number of circuits | Safety | 3 NO | | |
| | Additional | 1 solid-state output for signalling to PLC | | |
| Display | 2 LEDs | | | |
| Supply voltage | ~ and 24 V $\overline{\text{---}}$ 48 V \sim 115 V \sim 230 V \sim | | | |

| | | | | | |
|--|--|--|---|-------------------------|------------------------------|
| Synchronisation time between inputs | Unlimited | | | 75 ms (automatic start) | 1 |
| Input channel voltage | 24 V/48 V version | | ~ and 24 V $\overline{\text{---}}$ /48 V \sim | | 24 V $\overline{\text{---}}$ |
| | 24 V/48 V or 110 V/120 V/230 V version | | 115 V \sim /230 V \sim | | 48 V \sim /48 V \sim |

Module type

XPSAC XPSAXE XPSATE XPSATR

Pages

Please refer to our website www.schneider-electric.com

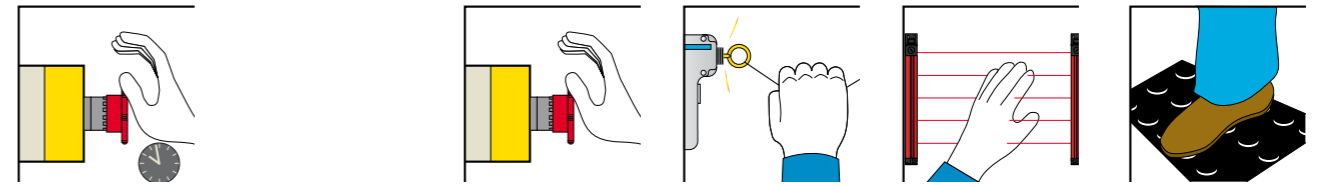

For Emergency stop and switch monitoring

For Emergency stop, switch or solid-state output safety light curtain monitoring

For Emergency stop, switch, sensing mat/edges or solid-state output safety light curtain monitoring



| | | | | | | |
|--|---|--|--|--|--|--|
| Maximum achievable safety level | PLe/Category 4 conforming to EN/ISO 13849-1, SILCL3 conforming to EN/IEC 61508 and EN/IEC 62061 | | | | | |
| Conformity to standards | EN/IEC 60204-1, EN 1088/ISO 14119, EN/ISO 13850, EN/IEC 60947-1, EN/IEC 60947-5-1 | | | | | |
| Product certifications | UL, CSA, TÜV | | | | | |

| | | | | | | | | | | | |
|---------------------------|------------------------------|---|------------------------------------|--------------------------------------|------------------------------------|------|--|--|--|--|--|
| Number of circuits | Safety | 3 NO instantaneous + 3 NO time delay | | 2 NO instantaneous + 1 NO time delay | | 3 NO | | 7 NO | | 3 NO instantaneous | |
| | Additional | 3 solid-state outputs for signalling to PLC | | - | | - | | 2 NC + 4 solid-state outputs for signalling to PLC | | 1 NC + 4 solid-state outputs for signalling to PLC | |
| Display | 11 LEDs | | 3 LEDs | | 3 LEDs | | 4 LEDs | | 4 LEDs | | |
| Supply voltage | 24 V $\overline{\text{---}}$ | | ~ and 24 V $\overline{\text{---}}$ | | ~ and 24 V $\overline{\text{---}}$ | | ~ and 24 V $\overline{\text{---}}$ 115 V \sim and 24 V $\overline{\text{---}}$ 230 V \sim and 24 V $\overline{\text{---}}$ | | ~ and 24 V $\overline{\text{---}}$ 48 V \sim 110 V \sim and 24 V $\overline{\text{---}}$ 120 V \sim and 24 V $\overline{\text{---}}$ 230 V \sim and 24 V $\overline{\text{---}}$ | | |

| | | | | | | | | |
|--|--|--|------------------------------|--|------------------------------------|--|---|--|
| Synchronisation time between inputs | Unlimited or 1.5 s (depending on wiring) | | Unlimited | | Unlimited | | Unlimited or 2 s, 4 s (depending on wiring) | |
| Input channel voltage | 24 V $\overline{\text{---}}$ | | 24 V $\overline{\text{---}}$ | | ~ and 24 V $\overline{\text{---}}$ | | 24 V $\overline{\text{---}}$ | |
| | - | | - | | - | | 24 V \sim /24 V $\overline{\text{---}}$ | |

Module type

XPSAV XPSABV XPSAF XPSAFL XPSAR XPSAK

Please refer to our website www.schneider-electric.com

Applications

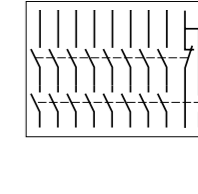
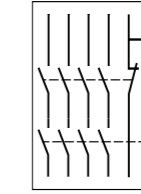
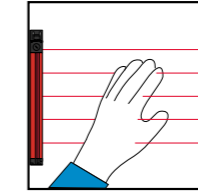
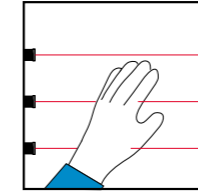
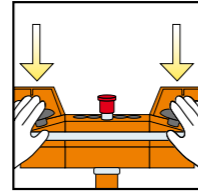
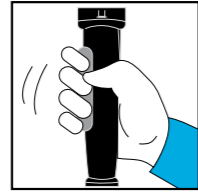

| Modules | For enabling switch monitoring | For electrical monitoring of two-hand control stations | | | For control of 1 to 4 single-beam photo-electric sensors XU2 S (transmitter-receiver pair) | For monitoring type 2 and type 4 light curtains Compact and slim ranges | For extending the number of safety contacts | | |
|---------|--------------------------------|--|--|--|--|---|---|--|--|
|---------|--------------------------------|--|--|--|--|---|---|--|--|



| Maximum achievable safety level | PLe/Category 4 conforming to EN/ISO 13849-1, SILCL3 conforming to EN/IEC 61508 and EN/IEC 62061 | PLc/Category 1 conforming to EN/ISO 13849-1, SILCL1 conforming to EN/IEC 62061 | PLe/Category 4 conforming to EN/ISO 13849-1, SILCL3 conforming to EN/IEC 61508 and EN/IEC 62061 | PLe/Category 4 conforming to EN/ISO 13849-1, SILCL3 conforming to EN/IEC 61508 and EN/IEC 62061 | PLc/Category 2 conforming to EN/ISO 13849-1, SILCL1 conforming to EN/IEC 61508 and EN/IEC 62061 | PLe/Category 4 conforming to EN/ISO 13849-1, SILCL3 conforming to EN/IEC 61508 and EN/IEC 62061 | PLe/Category 4 conforming to EN/ISO 13849-1, SILCL3 conforming to EN/IEC 61508 and EN/IEC 62061 (when connected to the appropriate module) | PLe/Category 4 conforming to EN/ISO 13849-1, SILCL3 conforming to EN/IEC 61508 and EN/IEC 62061 (when connected to the appropriate module) |
|---------------------------------|---|--|---|---|---|---|--|--|
| Conformity to standards | EN/IEC 60204-1, EN 61326, EN/IEC 60947-1, EN/IEC 60947-5-1 | EN 574 type III A, EN/IEC 60204-1, EN/IEC 60947-1, EN 62061 | EN/IEC 60204-1, EN/IEC 60947-1, EN/IEC 60947-5-1, EN 574 type III C/ISO 13851 | EN/IEC 60204-1, EN/IEC 60947-1, EN 574 type III C/ISO 13851 | EN/IEC 61496-1, EN/IEC 61496-2, EN/IEC 60204-1, EN/IEC 60947-1, EN/IEC 60947-5-1 | EN/IEC 61496-1, EN/IEC 61496-2, EN/IEC 60204-1, EN/IEC 60947-1, EN/IEC 60947-5-1 | EN/IEC 60204-1, EN/IEC 60947-1, EN/IEC 60947-5-1 | EN/IEC 60204-1, EN/IEC 60947-1, EN/IEC 60947-5-1 |
| Product certifications | UL, CSA, TÜV | UL, CSA, TÜV | UL, CSA, BG | UL, CSA, TÜV | UL, CSA, IFA | UL, CSA, TÜV | UL, CSA, BG | UL, CSA, TÜV |

| Number of circuits | Safety | 2 NO | 1 NO | 2 NO | 2 NO | 2 NO | 2 solid-state | 4 NO | 8 NO |
|-------------------------------------|------------------------------|---|---|------------------------------|---|--|--|---|------|
| | Additional | 2 solid-state outputs for signalling to PLC | 1 NC | 1 NC | 2 solid-state outputs for signalling to PLC | 4 solid-state PNP NO outputs for signalling to PLC | 1 PNP + 1 NPN output for signalling to PLC | 2 NC | 1 NC |
| Display | 3 LEDs | 2 LEDs | 3 LEDs | 3 LEDs | 4 LEDs | 14 LEDs + 2-digit display | 2 LEDs | 3 LEDs | |
| Supply voltage | 24 V $\overline{\text{---}}$ | \sim and 24 V $\overline{\text{---}}$ 115/230 V \sim | \sim and 24 V $\overline{\text{---}}$ 115/120 V \sim 230 V \sim | 24 V $\overline{\text{---}}$ | 24 V $\overline{\text{---}}$ | 24 V $\overline{\text{---}}$ | \sim and 24 V $\overline{\text{---}}$ | \sim and 24 V $\overline{\text{---}}$ 115 V \sim 230 V \sim | |
| Synchronisation time between inputs | – | 500 ms | 500 ms | 500 ms | – | 3 s or infinite | – | – | |
| Input channel voltage | 24 V/48 V version | 24 V $\overline{\text{---}}$ | 24 V $\overline{\text{---}}$ | 24 V $\overline{\text{---}}$ | – | – | – | – | |
| | 115 V/230 V version | – | 24 V \sim /24 V | – | – | – | – | – | |

| Module type | XPSVC | XPSBAE | XPSBCE | XPSBF | XPSCM | XPSLCM | XPSECME | XPSECE |
|-------------|-------|--------|--------|-------|-------|--------|---------|--------|
|-------------|-------|--------|--------|-------|-------|--------|---------|--------|

Pages Please refer to our website www.schneider-electric.com

Applications

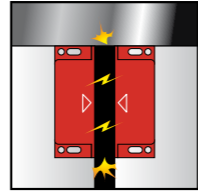
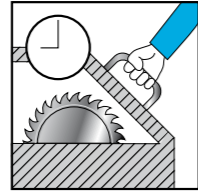

Modules

For the monitoring of applications requiring safety time delays

For coded magnetic switch monitoring

For 2 max.

For 6 max.



| | | | | |
|--|--|--|---|---|
| Maximum achievable safety level | PL d/Category 3 conforming to EN/ISO 13849-1, SILCL 2 conforming to EN/IEC 62061 | PL d/Category 3 conforming to EN/ISO 13849-1, SILCL 2 conforming to EN/IEC 62061 | PL e/Category 4 conforming to EN/ISO 13849-1, SILCL 3 conforming to EN/IEC 62061 | PL e/Category 4 conforming to EN/ISO 13849-1, SILCL 3 conforming to EN/IEC 62061 |
| Conformity to standards | EN/IEC 60204-1, EN/IEC 60947-1, EN/IEC 60947-5-1 | EN/IEC 60204-1, EN/IEC 60947-1, EN/IEC 60947-5-1 | EN/IEC 60204-1, EN 1088/ISO 14119, EN/IEC 60947-1, EN/IEC 60947-5-1, EN/IEC 60947-5-3 | EN/IEC 60204-1, EN 1088/ISO 14119, EN/IEC 60947-1, EN/IEC 60947-5-1, EN/IEC 60947-5-3 |
| Product certifications | UL, CSA, TÜV | UL, CSA, TÜV | UL, CSA, TÜV | UL, CSA, TÜV |

| | | | | |
|---------------------------|---|--|-----------------------------|---|
| Number of circuits | Safety | 1 NO time delayed | 1 NO pulse type | 2 NO |
| | Additional | 2 NC + 2 solid-state outputs for signalling to PLC | | 2 solid-state outputs for signalling to PLC |
| Display | 4 LEDs | | 3 LEDs | 15 LEDs |
| Supply voltage | ~ and 24 V $\overline{\text{DC}}$ 115 V \sim 230 V \sim | | $\overline{\text{DC}}$ 24 V | |

Synchronisation time between inputs

| | | |
|---|---|--------|
| - | - | 500 ms |
|---|---|--------|

Module type

| | | | |
|---------------|---------------|---------------|---------------|
| XPSTSA | XPSTSW | XPSDMB | XPSDME |
|---------------|---------------|---------------|---------------|

Pages

Please refer to our website www.schneider-electric.com

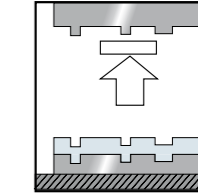
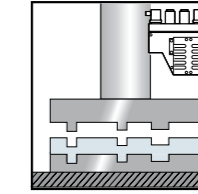
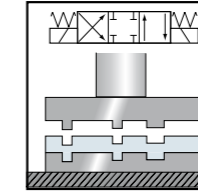
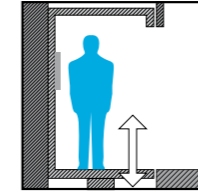
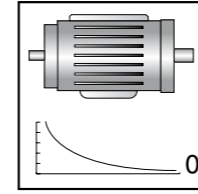

For zero speed detection of AC or DC motors which produce a remanent voltage in their windings due to residual magnetism

For lift control

For dynamic monitoring of hydraulic valves on linear presses

For dynamic monitoring of double-bodied solenoid valves

For safety stop at top dead centre with automatic overtravel monitoring and control



| | | | | |
|---|--|--|--|--|
| PL d/Category 3 conforming to EN/ISO 13849-1, SILCL 2 conforming to EN/IEC 62061, | PL e/Category 4 conforming to EN/ISO 13849-1, SILCL 3 conforming to EN/IEC 62061 | PL e/Category 4 conforming to EN/ISO 13849-1, SILCL 3 conforming to EN/IEC 62061 | PL e/Category 4 conforming to EN/ISO 13849-1, SILCL 3 conforming to EN/IEC 62061 | PL e/Category 4 conforming to EN/ISO 13849-1, SILCL 3 conforming to EN/IEC 62061 |
| EN/IEC 60204-1, EN/IEC 60947-1, EN/IEC 60947-5-1 | EN 81-1, EN 81-2, EN/IEC 60947-5-1, EN 12015, EN 12016 | EN 693, EN/IEC 60204-1, EN/IEC 60947-1, EN/IEC 60947-5-1 | EN 692, EN/IEC 60204-1, EN/IEC 60947-1, EN/IEC 60947-5-1 | EN 692, EN/IEC 60204-1, EN/IEC 60947-1, EN/IEC 60947-5-1 |
| UL, CSA, TÜV | TÜV | UL, CSA, TÜV | UL, CSA, TÜV | UL, CSA, TÜV |

| | | | | |
|---|--|-----------------------------|---|-----------------------------------|
| 1 NO + 1 NC | 2 NO | 2 NO + 1 NC | 1 NO + 1 NC | 3 NO |
| 2 solid-state outputs for signalling to PLC | | - | 4 solid-state outputs for signalling to PLC | |
| 4 LEDs | 4 LEDs | 8 LEDs | | |
| 24 V $\overline{\text{DC}}$ 115 V \sim 230 V \sim | \sim and 24 V $\overline{\text{DC}}$ | 24 V $\overline{\text{DC}}$ | 24 V $\overline{\text{DC}}$ 115 V \sim 230 V \sim | - 115 V \sim 230 V \sim |

Synchronisation time between inputs

| | | | | |
|---|----------|---|---|---|
| - | Infinite | - | - | - |
|---|----------|---|---|---|

Module type

| | | | | |
|---------------|---------------|---------------|---------------|--------------|
| XPSVNE | XPSEDA | XPSPVT | XPSPVK | XPSOT |
|---------------|---------------|---------------|---------------|--------------|

Please refer to our website www.schneider-electric.com

Applications

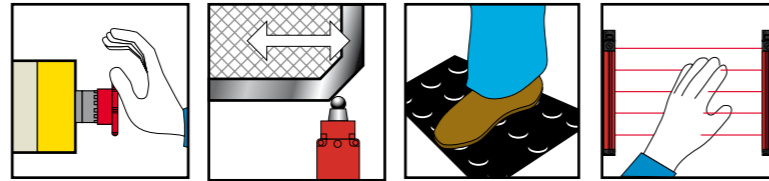

Modules

Controllers for monitoring 2 independent safety functions simultaneously. User selection of 2 functions from a choice of 15, programmable from front face of controller.



Functions

- Emergency stop monitoring
- Switch monitoring
- Enabling switch monitoring
- Sensing mat or edges monitoring
- Light curtain monitoring, relay output type
- etc.

Maximum achievable safety level

PL e/Category 4 conforming EN ISO 13849-1, SILCL 3 conforming to EN/IEC 61508 and EN/IEC 62061

Conformity to standards

EN/IEC 60204-1,
EN/IEC 60947-1,
EN/IEC 60947-5-1

Product certifications

UL, CSA, TÜV

Number of circuits

Safety
Additional

6 NO (3 NO per function)
3 solid-state outputs for signalling to PLC

Display

12 LEDs

Supply voltage

24 V ---

Communication

CANopen bus
Profibus bus
Modbus bus

–
–
–

Module type

XPSMP

Pages

Please refer to our website www.schneider-electric.com

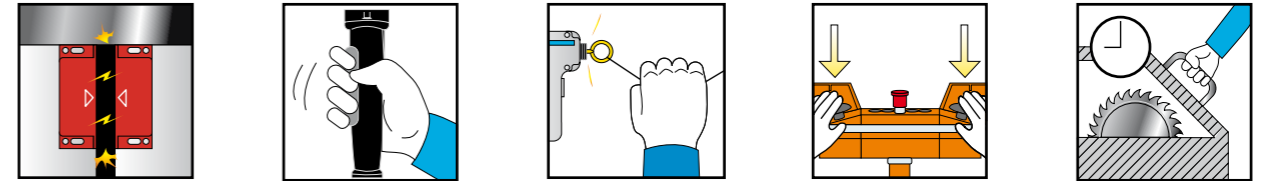

Configurable controllers using software, for several independent safety functions: selection of safety functions using configuration software running on Windows (16 or 32 inputs and 8 independent safety outputs)



- Emergency stop monitoring
- Limit switch monitoring
- Two-hand control monitoring
- Safety light curtain monitoring, with or without "muting" function
- Enabling switch monitoring, coded magnetic switch monitoring
- Safety mat monitoring
- Hydraulic press solenoid valve monitoring
- Eccentric press safety stop at top dead centre monitoring. Zero speed detection
- Hydraulic press monitoring
- Eccentric press monitoring
- Foot switch monitoring
- Chain shaft breakage monitoring
- Safe tool
- Position selector

PL e/Category 4 conforming to EN ISO 13849-1, SILCL 3 conforming to EN/IEC 61508 and EN/IEC 62061

EN/IEC 60204-1,
EN 1760-1/ISO 13856-1,
EN/IEC 61496-1,
EN 574/ISO 13851,
EN/IEC 60947-1,
EN/IEC 60947-5-1

UL, CSA, TÜV

4 NO (2 NO per function) + 6 solid-state

1 "muting" signalling output

LED display on front face

24 V ---

Via SUB-D 9-pin male connector, only on XPS MC16ZC and XPS MC32ZC

Via SUB-D 9-pin female connector, only on XPS MC16ZP and XPS MC32ZP

Via RJ45 connector, on all controllers XPS MC●●Z●

XPSMC

Please refer to our website www.schneider-electric.com

Machine safety

Compact Preventa safety PLCs

Presentation

Compact PLCs:

- Designed for use with numerous machine safety functions and for the protection of personnel.
- Designed for use in safety related parts of control systems up to category 4, performance level "e" EN/ISO 13849-1 and up to SIL 3 EN/IEC 61508.



| | | | |
|--|--|---|-----|
| User memory | Application | 250 kB | |
| | Data | 250 kB | |
| Response time | | Depending on size of application | |
| Maximum consumption | | 8 A | |
| Supply | | External $\bar{\text{---}}$ 24 V supply (with separate protection conforming to EN/IEC 60950, SELV (Safety Extra Low Voltage) or PELV (Protection Extra Low Voltage) rated) | |
| Inputs Digital | Number of channels | 24, configurable, not electrically isolated | |
| | Current at state 0 | 1.5 mA max. at $\bar{\text{---}}$ 24 V | |
| | Current at state 1 | 3.5 mA at $\bar{\text{---}}$ 24 V 4.5 mA at $\bar{\text{---}}$ 30 V | |
| Outputs Digital | Number of channels | 24, configurable, not electrically isolated | |
| | Output current | Channels 1 to 3, 5 to 7, 9 to 11, 13 to 15, 17 to 19, 21 to 23: 0.5 A at 60°C Channels 4, 8, 12, 16, 20 and 24: 1 A at 60 °C, 2 A at 50°C | |
| | Line control | 2 x 4 | |
| Input/output connections | | Removable screw terminals are provided with all Safety compact PLCs. Reference XPSMF40●● is also provided with cage clamp terminal. | |
| Communication on Ethernet network | By integrated RJ45 switched Ethernet communication ports | | |
| | ■ Safe communication using SafeEthernet protocol | Yes | Yes |
| | ■ Non safe communication using Modbus TCP/IP protocol, server (slave) | No | Yes |
| | Communication on fieldbus | | |
| Non safety using Modbus RTU protocol, slave (RS 485) | No | No | |
| Non safety using PROFIBUS DP protocol (V0 slave) | No | No | |
| Safety PLC type | | XPSMF4000 XPSMF4002 | |
| Pages | | Please refer to our website www.schneider-electric.com | |

Compact PLCs:

- Designed for use with numerous machine safety functions and for the protection of personnel.
- Designed for use in safety related parts of control systems up to category 4, performance level "e" EN/ISO 13849-1 and up to SIL 3 EN/IEC 61508.



| | | | |
|--|---|---|-----|
| | | 250 kB | |
| | | 250 kB | |
| | | Depending on size of application | |
| | | 8 A | |
| | | External $\bar{\text{---}}$ 24 V supply (with separate protection conforming to EN/IEC 60950, SELV (Safety Extra Low Voltage) or PELV (Protection Extra Low Voltage) rated) | |
| Inputs Digital | Number of channels | 24, configurable, not electrically isolated | |
| | Current at state 0 | 1.5 mA max. at $\bar{\text{---}}$ 24 V | |
| | Current at state 1 | 3.5 mA at $\bar{\text{---}}$ 24 V 4.5 mA at $\bar{\text{---}}$ 30 V | |
| Outputs Digital | Number of channels | 24, configurable, not electrically isolated | |
| | Output current | Channels 1 to 3, 5 to 7, 9 to 11, 13 to 15, 17 to 19, 21 to 23: 0.5 A at 60°C Channels 4, 8, 12, 16, 20 and 24: 1 A at 60 °C, 2 A at 50°C | |
| | Line control | 2 x 4 | |
| Input/output connections | | Removable screw terminals are provided with all Safety compact PLCs. Reference XPSMF40●● is also provided with cage clamp terminal. | |
| Communication on Ethernet network | By integrated RJ45 switched Ethernet communication ports | | |
| | Yes | Yes | Yes |
| | No | Yes | No |
| | Yes | Yes | No |
| No | No | Yes | Yes |
| Safety PLC type | | XPSMF4020 XPSMF4022 XPSMF4040 XPSMF4042 | |
| Pages | | Please refer to our website www.schneider-electric.com | |

chapter 7

General Motion control



All technical information about products listed in this chapter
are available on www.schneider-electric.com

- **General presentation**
 - Maximum productivity for your machines 7/2
 - Whatever your performance needs are,
our high-performance drives and motors offer a range of choices..... 7/3
- **Servo Drives and Motors**
 - Lexium 23 Plus Servo Drives 7/4
 - Servo motors for Lexium 23 Plus 7/5
 - Lexium 32 Servo Drives..... 7/6
 - Motors for Lexium 32 7/7
- **Integrated drives**
 - Lexium 32i, ILA, ILE, ILS 7/8 and 7/9
- **Lexium Linear Motion**
 - Linear axes 7/10
 - Multi-axis systems..... 7/12



- > A complete product range
- > solution competency
- > the power of motion
- > connectivity
- > global availability

make Schneider Electric your partner of choice for cost-effective and energy-efficient machine automation

Schneider Electric, you can rely on us!

Maximum productivity for your machines

Complete Motion offer

- > Complete and scalable motion range with outstanding servo control loops for virtually all kinds of machines
- > Wide range of linear motion and robotic products and capacity for customization and 3rd party motors

Simplicity

- > Our motion products are designed for maximum simplicity over the entire machine lifecycle to reduce costs and make your machine processes even more productive
- > Our motion products are easy to integrate into your machine environments through standard software tools, motion libraries and application function blocks

Openness

- > Our products support standardized motion interfaces: Sercos, CANopen, CANmotion, Profibus, DeviceNet, Ethernet IP, EtherCAT, Ethernet Powerlink, Modbus TCP and Pulse Train
- > This allows you to efficiently design machines which can easily be integrated into your customers' automation architectures

Safety

- > Safe Torque Off (STO) embedded in the drives
- > Advanced safety functions: Safe Stop (SS1, SS2), Safety Limited Speed (SLS), Safe Operating Stop (SOS) as option available

With superior performance in the market and embedded safety, our wide range of motion products supports standardized motion interfaces to assist integration.

If you need even more performance, our PacDrive offer is your product of choice. With its centralized system architecture, PacDrive is the ideal solution for controlling a broad range of servo-driven production and packaging machines, as well as material handling equipment.



Whatever your performance needs are, our high-performance drives and motors offer a range of choices

If you need coordinated or synchronized motion control, Schneider Electric offers a wide range of servo drives and integrated drives for machine automation. With a power range up to 25 kW there is the right drive for your application.

Lexium 52/62

- > High-Performance servo drive
- > Single (LXM52) and multi axis (LXM62)
- > Safety on Sercos
- > 0.4 kW to 25 kW

Lexium 32

- > Flexible servo drive
- > Powerful control loop
- > Embedded safety
- > 0.15 kW to 7 kW

Lexium 23 Plus

- > Optimized servo drive
- > Small form factor
- > 0.1 kW to 7.5 kW

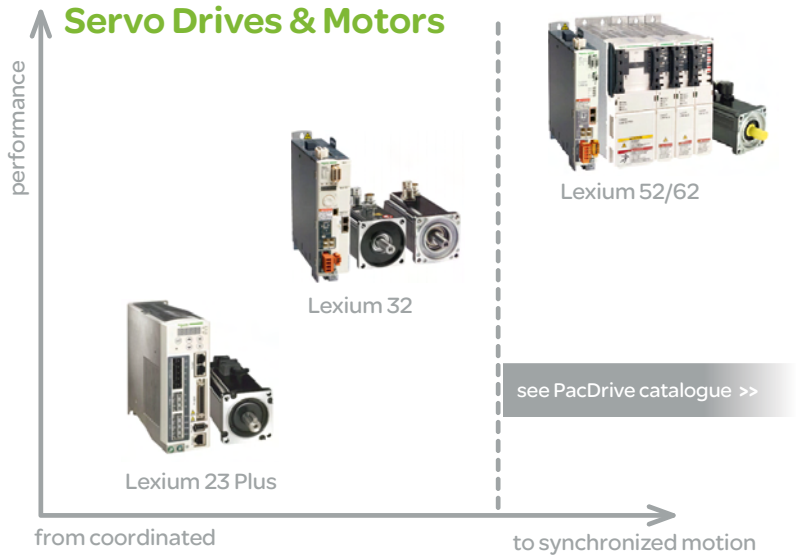

Lexium ILM62

- > Single cable solution
- > Sercos interface
- > Safety on Sercos
- > 0.3 kW to 2 kW

Lexium 32i

- > Modular servo drive
- > CANmotion interfaces
- > Embedded safety
- > 0.6 kW to 2.2 kW



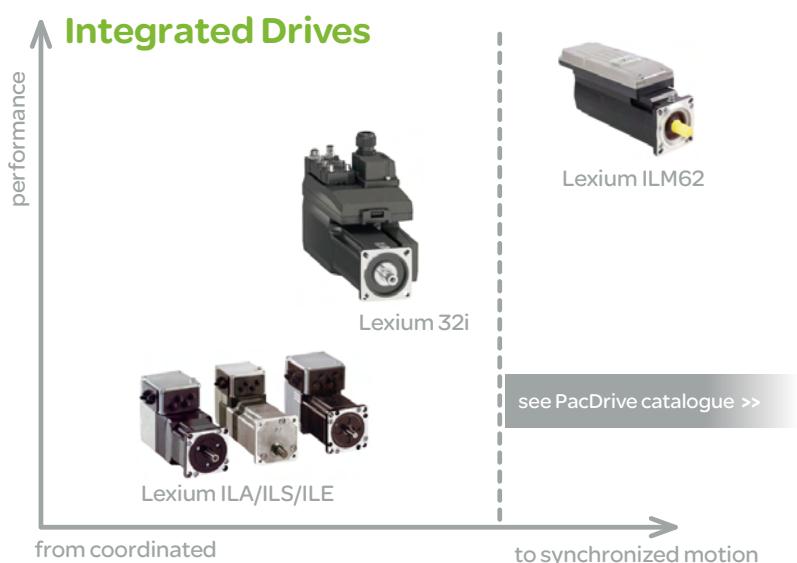

Lexium ILA/ILS/ILE

- > Extremely compact drive
- > Servo, stepper and brushless
- > Large choice of interfaces
- > 0.1 kW to 0.4 kW





| Servo drive | Lexium23A-CAN version | Lexium23D-Pulse Train version |
|----------------------------|--|--|
| |  |  |
| Communication | CANopen CANmotion Pulse Train RS232 | Pulse Train RS232 |
| Operating modes | Jog mode Profile Position mode Profile Velocity mode Profile Torque mode Homing mode | Electronic gearbox Positioning mode Speed mode Torque mode |
| Functions | Auto-tuning 2-notch filters Position capture | Auto-tuning 2-notch filters Position capture |
| 24V logic inputs | 8 reassignable | 8 reassignable |
| 24V logic outputs | 5 reassignable | 5 reassignable |
| Analog inputs | 2 | 2 |
| Pulse control input | RS422 500 kHz (standard)/4 MHz (high-speed) 200 kHz open collector | |
| ESIM PTO output | 1 RS422 | 1 RS422 |
| Encoder | High-speed pulse train | |
| Architecture | Control via: CANopen CANmotion Pulse Train Analog input | Control via: Pulse Train Analog input |
| Type of servo drive | LXM23A | LXM23D |

| Servo motor | |
|--------------------------------|--|
| |  |
| Application type | From ultra-low inertia to high inertia, suitable for highly dynamic and high-load applications |
| Flange size | 40, 60, 80, 100, 130 and 180 mm |
| Continuous stall torque | 0.32 to 47.74 Nm |
| Encoder type | 20-bit incremental |
| Degree of protection | Casing Shaft end |
| | IP65 IP40 (standard)/IP65 (option) |
| Type of servo motor | BCH |

| Servo Drives | | Lexium 32 Compact | Lexium 32 Advanced | Lexium 32 Modular | Lexium 32 Sercos |
|----------------------|---|--|---|--|---|
| | |  |  |  |  |
| Communication | Integrated | Modbus serial link Pulse train | Modbus serial link CANopen, CANmotion machine bus | Modbus serial link Pulse train | Modbus serial link Sercos III |
| | As an option | – | – | CANopen, CANmotion machine bus, DeviceNet, EtherNet/IP, PROFIBUS DP, EtherCAT, I/O module | – |
| | Operating modes | Manual mode (JOG), Electronic gearbox, Speed control, Current control | Homing, Manual mode (JOG), Speed control, Current control, Position control | Homing, Manual mode (JOG), Motion sequence, Electronic gearbox, Speed control, Current control, Position control | Homing, Manual mode (JOG), Speed control, Current control, Position control |
| | Functions | Auto-tuning, monitoring, stopping, conversion | | | |
| | | – | Stop window, Rapid entry of position values | Stop window, Rapid entry of position values, Rotary axes, Position register | Stop window Rapid entry of position values |
| | 24 V \bar{c} logic inputs | 6, reassignable | 3, reassignable | 4, reassignable | 4, reassignable |
| | 24 V \bar{c} capture inputs (1) (2) | – | 2 | 3 | 3 |
| | 24 V \bar{c} logic outputs (1) | 5, reassignable | 2, reassignable | 3, reassignable | 3, reassignable |
| | Analog inputs | 2 | – | – | – |
| | Pulse control input | 1, configurable as: <input type="checkbox"/> RS 422 link <input type="checkbox"/> 5 V or 24 V push-pull <input type="checkbox"/> 5 V or 24 V open collector | | | |
| | ESIM PTO output | RS 422 link | – | RS 422 link | – |
| | Safety functions | "Safe Torque Off" STO | | | |
| | Integrated | – | | | |
| | As an option | Safe Stop 1 (SS1) and Safe Stop 2 (SS2) Safe Operating Stop (SOS) Safe Limited Speed (SLS) | | | |
| | Sensor | SinCos Hiperface® sensor | | | |
| | Integrated | – | | | |
| | As an option | Resolver encoder Analog encoder Digital encoder | | | |
| | Architecture | Control via | | | |
| | | Logic or analog I/O | Motion controller via CANopen and CANmotion machine bus | Schneider Electric or third-party PLCs via communication buses and networks | Modicon LMC078 Sercos III network |
| | Type of Servo Drive | LXM32C | LXM32A | LXM32M | LXM32S |

(1) Unless otherwise stated, the logic I/O can be used in positive logic (Sink inputs, Source outputs) or negative logic (Source inputs, Sink outputs).
(2) The capture inputs can be used as standard logic inputs.

| Servo motors | | |
|---|--|--|
|  | | |
|  | | |
| Application type | High load, With robust adjustment of the movement | High dynamic range, Power density |
| Flange size | 70, 100, 140, 190, and 205 mm (2.76, 3.94, 5.51, 7.48, and 8.07 in.) | 55, 70, 100, and 140 mm (2.17, 2.76, 3.94, and 5.51 in.) |
| Continuous stall torque | 1.2 to 84 Nm | 0.5 to 33.4 Nm |
| Encoder type | <input type="checkbox"/> Single turn SinCos: 32,768 points/turn and 131,072 points/turn <input type="checkbox"/> Multiturn SinCos: 32,768 points/turn x 4,096 turns and 131,072 points/turn x 4,096 turns | <input type="checkbox"/> Single turn SinCos: 131,072 points/turn <input type="checkbox"/> Multiturn SinCos: 131,072 points/turn x 4,096 turns |
| Degree of protection | Casing Shaft end | IP 65 (IP 67 conformity kit as an option) IP 50 or IP 65 (IP 67 conformity kit as an option) |
| Type of servo motor | BMH | BSH |

| | | |
|---------------------|--|--|
| Type of application | Machine auxiliary axes or low-power applications | Machines with high power applications |
| Type of solution | Integrated drive system in order to optimize the size of the enclosure | Integrated drive system in order to optimize the size of the enclosure |



| | | |
|------------------------------------|--|---|
| Type of process | Requiring high dynamic performance and precise positioning | Automatic format adjustment |
| Technology type | Integrated drive with servo motor | Integrated drive with DC brushless motor |
| Main characteristics | Compact Optional integrated holding brake | High holding torque with power off Optional integrated planetary gearbox |
| Dynamic response | ★★★★ | ★★ |
| Precision and stability | ★★★★ | ★★ |
| Economy mode | ★★★★★ | ★★★★★ |
| Motor inertia | Medium | |
| Control interfaces | I/O | |
| Control signals | CANopen, PROFIBUS DP, RS 485 serial link, DeviceNet, EtherCAT, Ethernet/IP, Modbus TCP, Ethernet Powerlink | |
| Buses and networks | - | |
| Motion bus | - | |
| Motor-drive combination | Nominal power | |
| | 150...370 W | 100...350 W |
| | Nominal speed | |
| | 500...9000 rpm | 1500...7000 rpm |
| | Nominal torque | |
| | 0.26...0.78 Nm | 0.18...0.5 Nm |
| Drive characteristics | Safety function | |
| | Safe Torque Off | |
| Power section line supply | 24...48 V ~ | |
| Power supply Input voltage control | Power supply shared with the power section line supply | |
| Input current | Power supply shared with the power section line supply | |
| Motor characteristics | Type of sensor (resolution) (1) | |
| | <input type="checkbox"/> Single-turn SinCos encoder (16,384 pulses/rev) <input type="checkbox"/> Multi-turn SinCos encoder (16,384 pulses/rev x 4096 revolutions) | Absolute encoder (12...1380 pulses/rev) |
| Flange size | 57 mm | 66 mm |
| Type of integrated drive | ILA | ILE |

(1) Sensor resolution given for the drive-motor combination.

| | |
|--|--|
| Short distances and precise positioning | High power, dynamic and precise positioning |
| Integrated drive with 3-phase stepper motor | Integrated drive with servo motor |
| High torque at low speed | High power and flexibility |
| ★★★ | ★★★★ |
| ★★★★ | ★★★★ |
| ★★ | ★★★★★ |
| Medium | Medium |
| Pulse/direction (P/D) I/O | I/O |
| CANopen, PROFIBUS DP, RS 485 serial link, DeviceNet, EtherCAT, Ethernet/IP, Modbus TCP, Ethernet Powerlink | CANopen, EtherCAT |
| - | CANmotion |
| 100...350 W | 400...2100 W |
| 0...1000 rpm | 1500...4700 rpm |
| 0.45...6 Nm | 1.7...7.2 Nm |
| Safe Torque Off | Safe Torque Off |
| 24-36-48 V ~ | 1 ~ 115...240 V ~, 3 ~ 400...480 V ~ |
| Power supply shared with the power section line supply | Power supply shared with the power section line supply |
| Power supply shared with the power section line supply | Power supply shared with the power section line supply |
| Reference impulse sensor | <input type="checkbox"/> Single-turn SinCos encoder (32,768 points/turn and 131,072 points/turn) <input type="checkbox"/> Multiturn SinCos encoder (32,768 points/turn x 4,096 turns and 131,072 points/turn x 4,096 turns) |
| 57 and 85 mm | 70 and 100 mm |
| ILS | LXM32i + BMI |

General Motion Control

Lexium Linear Motion

Linear axes

| Axis type | | Portal axes | |
|---------------|----------------------|----------------------|-----------|
| Movement | Number of directions | 1 | |
| | Movement type | Generally horizontal | |
| | Position of the load | On carriage | |
| Drive | | Toothed belt | Ballscrew |
| Type of guide | | Ball or roller | Ball |

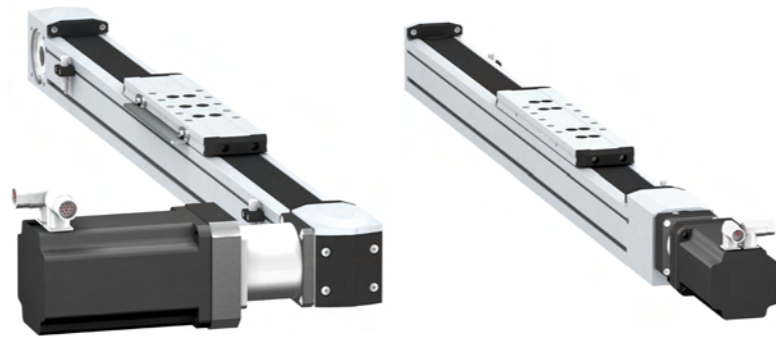

| | | |
|--|---|---|
| Main characteristics | <ul style="list-style-type: none"> High dynamic response Long stroke length High positioning speed | <ul style="list-style-type: none"> High precision movement (positioning, repeatability, guiding) High feed forces High rigidity |
| Dynamic response | ★★★★★ | ★★★ |
| Precision | ★★★ | ★★★★★ |
| Maximum payload | 100 kg | 100 kg |
| Maximum driving force | 2600 N | 4520 N |
| Maximum speed of movement of the load | 8 m/s | 1.25 m/s |
| Maximum working stroke | 5500 mm | 3000 mm |
| Repeatability | ± 0.05 mm | ± 0.02 mm |
| Options | <ul style="list-style-type: none"> Choice of guide type: Ball (for applications requiring high forces and torques) or roller (simple, cost-effective solution) Wide range of sensors for the limit switch function Choice of carriage type for adapting to the load Option to add carriages Anti-corrosion version Anti-static belt | <ul style="list-style-type: none"> Choice of pitch Protective metal strip Wide range of sensors for the limit switch function Choice of carriage type for adapting to the load Option to add carriages Option to add ballscrew supports for longer axes |
| Type of Linear axes | PAS4●B | PAS4●S |

| Linear tables | Cantilever axes with mobile structure on profile | Cantilever axes with mobile structure on parallel rods | Telescopic axes |
|----------------------|---|--|----------------------|
| 1 | | | |
| Generally horizontal | Generally vertical | | Generally horizontal |
| On carriage | On the side of the profile or on the 2 end blocks | On the 2 end blocks | On carriage |
| Ballscrew | Toothed belt | Toothed belt or rack | Toothed belt |
| Double, ball | Ball or roller | Ball | Ball or roller |

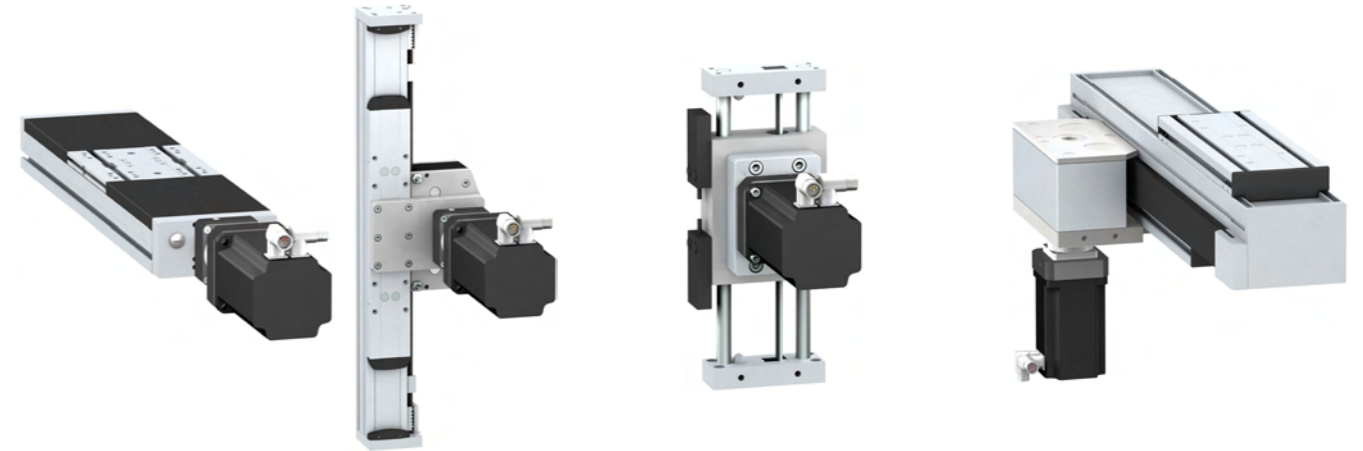

| | | | |
|---|--|--|---|
| <ul style="list-style-type: none"> High precision movement (positioning, repeatability, guiding) High feed forces High rigidity Feed movement without mechanical backlash | <ul style="list-style-type: none"> Long stroke length High feed forces Option to mount the load on the side of the profile or on the end blocks High rigidity | <ul style="list-style-type: none"> Compact Mobile structure with light travel weight | <ul style="list-style-type: none"> Long stroke length from a compact unit High rigidity High dynamic response |
| ★★ | ★★★★ | ★★★★ | ★★★★ |
| ★★★★★ | ★★★ | ★★★ | ★★ |
| 150 kg | 50 kg | 18 kg | 35 kg |
| 2580 N | 2150 N | 705 N | 1500 N |
| 1 m/s | 3 m/s | 3 m/s | 3 m/s |
| 1500 mm | 1200 mm | 500 mm | 2400 mm |
| ± 0.02 mm | ± 0.05 mm | ± 0.05 mm | ± 0.1 mm |
| <ul style="list-style-type: none"> Choice of pitch Several different motor mounting options | <ul style="list-style-type: none"> Choice of guide type: Ball (for applications requiring high forces and torques) or roller (simple, cost-effective solution) Protective metal strip Anti-corrosion version Wide range of sensors for the limit switch function Anti-static belt | <ul style="list-style-type: none"> Anti-corrosion version Anti-static belt | <ul style="list-style-type: none"> Choice of guide type: Ball (for applications requiring high forces and torques) or roller (simple, cost-effective solution) Choice of carriage type for adapting to the load |
| TAS4 | CAS4 | CAS3 | CAS2 |

General Motion Control

Lexium Linear Motion

Multi-axis systems

| | | |
|-------------------------------|--|--|
| Axis type | Double portal axes | |
| Movement | 1 | |
| Number of directions | Horizontal: Combination of two parallel axes X and Y | |
| Movement type | On two parallel carriages | |
| | PAS 4●B axes + PAS 4●H support axis (driven by the load) | |
| | PAS 4●B + PAS 4●B axes (shaft-driven) | |
| Multi-axis system type | Toothed belt on one axis | |
| Drive | Toothed belt on both axes | |
| Type of guide | Ball or roller | |



| | | |
|-----------------------------------|---|--|
| Main characteristics | <ul style="list-style-type: none"> <input type="checkbox"/> Long stroke length <input type="checkbox"/> High dynamic response <input type="checkbox"/> High precision movement (positioning, guiding) | <ul style="list-style-type: none"> <input type="checkbox"/> High precision movement (positioning, guiding) <input type="checkbox"/> High feed forces |
| Maximum payload | 250 kg | 300 kg |
| Maximum working stroke | On the X axis | 5500 mm |
| | On the Y axis | – |
| | On the Z axis | – |
| Options | <ul style="list-style-type: none"> <input type="checkbox"/> Choice of guide type: Ball (for applications requiring high forces and torques) or roller (simple, cost-effective solution) <input type="checkbox"/> Protective metal strip <input type="checkbox"/> Anti-corrosion version <input type="checkbox"/> Anti-static belt <input type="checkbox"/> Wide range of sensors for the limit switch function <input type="checkbox"/> Several different motor mounting options <input type="checkbox"/> Variable distance between the two axes | |
| Type of Multi-axis systems | MAXH | MAXS |

| | | |
|--|--|--|
| Linear positioners | Portal robots | |
| 2 | 3 | |
| Horizontal and vertical: Combination of one X axis and one Z axis | Horizontal: Combination of two perpendicular axes X and Y | Horizontal and vertical: Combination of two perpendicular axes X and Y and one Z axis |
| On the side or on the end blocks of the Z axis profile | On the Y axis carriage | On the side or on the end blocks of the Z axis profile |
| <ul style="list-style-type: none"> <input type="checkbox"/> MAX S + CAS 4 axes <input type="checkbox"/> MAX S + CAS 3 axes | <ul style="list-style-type: none"> <input type="checkbox"/> MAX S + MAX H axes <input type="checkbox"/> MAX S + PAS 4●B axes | <ul style="list-style-type: none"> <input type="checkbox"/> MAX S + MAX H + CAS 4 axes <input type="checkbox"/> MAX S + MAX H + CAS 3 axes |
| Toothed belt on each axis | | |
| Ball or roller | | |

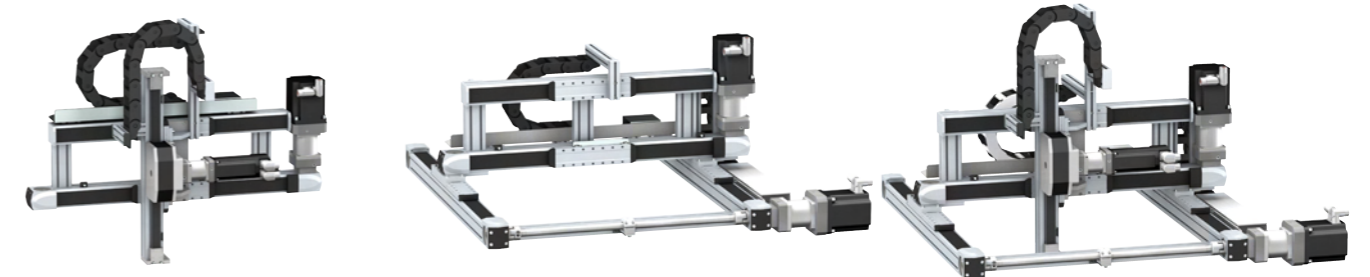

| | | |
|--|--|---|
| <input type="checkbox"/> Dynamic load positioning | <input type="checkbox"/> Long stroke length on both axes | <input type="checkbox"/> Long stroke length on three axes |
| 50 kg | 130 kg | 50 kg |
| 5500 mm | 5500 mm | 5500 mm |
| – | 1500 mm | 1500 mm |
| 1200 mm | – | 1200 mm |
| <ul style="list-style-type: none"> <input type="checkbox"/> Choice of guide type: Ball (for applications requiring high forces and torques) or roller (simple, cost-effective solution) <input type="checkbox"/> Wide range of sensors for the limit switch function Supplied as standard: <ul style="list-style-type: none"> <input type="checkbox"/> Protective metal strip <input type="checkbox"/> Anti-corrosion version <input type="checkbox"/> Anti-static belt | | |
| MAXP | MAXR●2 | MAXR●3 |

chapter 8

Related products



All technical information about products listed in this chapter are available on www.schneider-electric.com

- **Soft starters for synchronous and asynchronous motors**
 - Selection guide 8/2
- **Variable speed drives**
 - Selection guide 8/4
- **Operator dialogue terminals**
 - **Magelis™ Small panels**
 - Selection guide 8/6
 - **Magelis™ Advanced Panels**
 - Selection guide8/8 and 8/10
 - **Magelis™ Optimum Advanced terminals**
 - Selection guide 8/12
- **Control and signaling components**
 - **Control and signaling units**
 - Selection guide 8/14
 - **Control stations and enclosures**
 - Selection guide 8/16
- **Control and protection components**
 - **TeSys T Motor Management System**
 - Selection guide 8/18
 - **Motor starter solutions with 1, 2 or 3 products**
 - Panorama 8/20
 - **Short-circuit and overload protection**
 - Panorama 8/22
 - **Incoming protection and switching**
 - Panorama 8/24
- **Phaseo Power supplies**
 - Selection guide 8/26
- **Indication and metering**
 - Panorama 8/28
- **Power distribution and connection systems**
 - Panorama 8/30
- **Spacial enclosures**
 - Panorama 8/32

Related products

Soft starters for synchronous and asynchronous motors

| Application | Soft starter | Soft start/soft stop unit |
|-------------|--|---------------------------|
| | For conveyors, conveyor belts, pumps, fans, compressors, automatic doors, small gantries, belt-driven machines, etc. | |

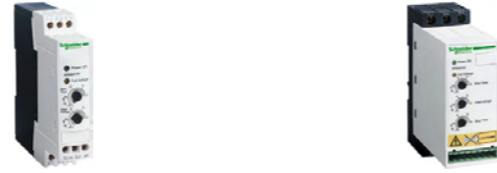

| Power range for 50...60 Hz (kW) line supply | 0.37...11 | 0.75...15 |
|---|------------|------------|
| Single-phase 110...230 V (kW) | 0.37...2.2 | – |
| Three-phase 200...240 V (kW) | – | 0.75...7.5 |
| Three-phase 200...480 V (kW) | 0.37...11 | – |
| Three-phase 208...600 V (kW) | – | – |
| Three-phase 208...690 V (kW) | – | – |
| Three-phase 230...415 V (kW) | – | – |
| Three-phase 230...440 V (kW) | – | – |
| Three-phase 380...415 V (kW) | – | 1.5...15 |

| Degree of protection | IP 20 | | |
|----------------------|-----------------------------|---|---|
| Drive system | Number of controlled phases | 1 | 2 |
| Type of control | – | – | |
| Operating cycle | – | – | |

| Functions (number) | 1 Bypass |
|-------------------------|---|
| Safety functions | Integrated |
| Available as an option | – |
| Number of preset speeds | – |
| Number of I/O | Analog inputs Logic inputs Analog outputs Logic outputs Relay outputs |
| Communication | Integrated |
| Available as an option | – |

| Dialogue tools | – |
|----------------|----------------|
| Configuration | Setup software |

| Standards and certifications | IEC/EN 60947-4-2 |
|------------------------------|--------------------------|
| | CE, UL, CSA, C-Tick, CCC |

| References | ATS01N1 ●●●● | ATS01N2 ●●●● |
|------------|---------------------|---------------------|
|------------|---------------------|---------------------|

| Soft start/soft stop unit |
|--|
| For centrifugal pumps, piston pumps, fans, screw compressors, conveyors, agitators, mixers, centrifugal machines, etc. |



| Power range for 50...60 Hz (kW) line supply | 4...400 |
|---|---------|
| Single-phase 110...230 V (kW) | – |
| Three-phase 200...240 V (kW) | – |
| Three-phase 200...480 V (kW) | – |
| Three-phase 208...600 V (kW) | 4...400 |
| Three-phase 208...690 V (kW) | – |
| Three-phase 230...415 V (kW) | – |
| Three-phase 230...440 V (kW) | 4...355 |
| Three-phase 380...415 V (kW) | – |

| Degree of protection | IP 20 | |
|----------------------|-----------------------------|---|
| Drive system | Number of controlled phases | 3 |
| Type of control | Configurable voltage ramp | |
| Operating cycle | Standard | |

| Functions (number) | 1 Bypass |
|-------------------------|--|
| Safety functions | Integrated |
| Available as an option | – |
| Number of preset speeds | – |
| Number of I/O | 1 PTC probe 3 – – 2 ("N/C"/"N/O") Modbus – |
| Communication | Integrated |
| Available as an option | – |

| Dialogue tools | – |
|----------------|----------------|
| Configuration | Setup software |

| Standards and certifications | IEC/EN 60947-4-2, EMC class A |
|------------------------------|--------------------------------|
| | CE, UL, CSA, C-Tick, GOST, CCC |

| References | ATS22 ●●●● |
|------------|-------------------|
|------------|-------------------|

Related products

Variable speed drives for asynchronous and synchronous motors

| Application | | Variable speed drive | |
|---|--|---|--|
| | | For material handling (small conveyors), packing and packaging (small labelling machines, small bagging machines), suction pumps, centrifugal pumps, circulating pumps, air or smoke extractor fans, plastic film making machines, ovens, boilers, etc. | For material handling (small conveyors), hoists, packing and packaging (small labelling machines, small bagging machines), special machines (mixers, kneaders), textile machines, pumps, compressors, fans, etc. |
| | |  |  |
| Power range for 50...60 Hz (kW) line supply | | 0.18...4 | 0.18...15 |
| Single-phase 100...120 V (kW) | | 0.18...0.75 | – |
| Single-phase 200...240 V (kW) | | 0.18...2.2 | 0.18...2.2 |
| Three-phase 200...230 V (kW) | | – | – |
| Three-phase 200...240 V (kW) | | 0.18...4 | 0.18...15 |
| Three-phase 380...480 V (kW) | | – | – |
| Three-phase 380...500 V (kW) | | – | 0.37...15 |
| Three-phase 500...600 V (kW) | | – | – |
| Three-phase 525...600 V (kW) | | – | 0.75...15 |
| Three-phase 500...690 V (kW) | | – | – |
| Degree of protection | | IP 20 | IP 21 |
| Type of cooling | | Heatsink | |
| Drive system | | 0.1...400 Hz | 0.1...500 Hz |
| Output frequency | | | |
| Type of control | | Asynchronous motor | Standard (voltage/frequency) Performance (sensorless flux vector control) Pump/fan (Kn ² quadratic ratio) |
| | | | Standard (voltage/frequency) Performance (sensorless flux vector control) Energy saving ratio |
| | | | – |
| Synchronous motor | | – | – |
| Transient overtorque | | 150...170% of the nominal motor torque | 170...200% of the nominal motor torque |
| Functions (number) | | 40 | 50 |
| Safety functions | | – | – |
| Integrated | | – | – |
| Available as an option | | – | – |
| Number of preset speeds | | 8 | 16 |
| Number of I/O | | 1 | 3 |
| Analog inputs | | 4 | 6 |
| Logic inputs | | 1 | 1 |
| Analog outputs | | 1 | – |
| Logic outputs | | 1 | – |
| Relay outputs | | 1 | 2 |
| Communication | | Modbus | Modbus and CANopen |
| Integrated | | – | CANopen Daisy Chain, DeviceNet, PROFIBUS DP, Modbus TCP, Fipio |
| Available as an option | | – | – |
| Bluetooth link® | | – | – |
| Options | | – | – |
| Dialogue tools | | IP 54 or IP 65 remote terminal | IP 54 or IP 65 remote terminal IP 54 remote graphic display terminal |
| Configuration | | SoMove Simple Loader, Multi-Loader | SoMove Simple Loader, Multi-Loader |
| Standards and certifications | | IEC 61800-5-1 IEC 61800-3 (environments 1 and 2, categories C1 to C3) | |
| | | CE, UL, CSA, C-Tick, NOM, GOST | |
| References | | ATV12 | ATV312 |

| Variable speed drives without sensor (velocity control) | | Variable speed drive | |
|---|--|---|---|
| | | For material handling (conveyors), transfer machines, packaging machines, hoisting, special machines (textile, transfer), wood-working or metal processing machines, etc. | For hoisting, material handling, packaging, textile machines, wood-working machines, process machines |
| | |  |  |
| Power range for 50...60 Hz (kW) line supply | | 0.18...15 | 0.37...630 |
| Single-phase 100...120 V (kW) | | – | – |
| Single-phase 200...240 V (kW) | | 0.18...2.2 | 0.37...5.5 |
| Three-phase 200...230 V (kW) | | – | – |
| Three-phase 200...240 V (kW) | | – | 0.37...7.5 |
| Three-phase 380...480 V (kW) | | – | 0.75...500 |
| Three-phase 380...500 V (kW) | | 0.37...15 | – |
| Three-phase 500...600 V (kW) | | – | 1.5...7.5 |
| Three-phase 525...600 V (kW) | | – | – |
| Three-phase 500...690 V (kW) | | – | 1.5...630 |
| Degree of protection | | IP 20 | IP 20 |
| Type of cooling | | Heatsink | |
| Drive system | | 0.1...599 Hz | 0.1...500 Hz across the entire range 0.1...599 Hz up to 37 kW at 200...240 V ~ and 380...480 V ~ |
| Output frequency | | | |
| Type of control | | Voltage/frequency ratios: U/f and 5-point U/f Sensorless flux vector control ratio Kn ² quadratic ratio (pump/fan) Energy saving ratio | Flux vector control with or without sensor Voltage/frequency ratio (2 or 5 points). ENA System |
| | | Ratio for synchronous motor without sensor | Vector control with or without speed feedback |
| Transient overtorque | | 170...200% of the nominal motor torque | 220% of nominal motor torque for 2 seconds, 170% for 60 seconds |
| Functions (number) | | 150 | > 150 |
| Safety functions | | 1: STO (Safe Torque Off) 3: SLS (Safe Limited Speed), SDI (Safe Direction Information), SS1 (Safe Stop 1) | "Power removal" (PWR) safety function |
| Integrated | | – | – |
| Available as an option | | – | – |
| Number of preset speeds | | – | 16 |
| Number of I/O | | 3 | 2...4 |
| Analog inputs | | 6 | 6...20 |
| Logic inputs | | 1 : configurable as voltage (0-10 V) or current (0-20 mA) | 1...3 |
| Analog outputs | | 1 | 0...8 |
| Logic outputs | | 2 | 2...4 |
| Relay outputs | | – | – |
| Communication | | Modbus, CANopen | Modbus, CANopen |
| Integrated | | DeviceNet, PROFIBUS DP V1, EtherNet/IP, Modbus TCP, EtherCat | Modbus TCP Daisy Chain, Modbus/Uni-Telway, EtherNet/IP, DeviceNet, PROFIBUS DP V0 and V1, INTERBUS, CC-Link |
| Available as an option | | – | – |
| Bluetooth link® | | – | – |
| Options | | Filters, braking resistors, line chokes | ATVIMC integrated controller card, interface cards for incremental, resolver, SinCos, SinCos Hiperface®, EnDat® or SSI encoders, I/O extension cards, "Controller Inside" programmable card |
| Dialogue tools | | IP 54 or IP 55 drive navigator IP 54 or IP 55 remote graphic display terminal | IP 54 or IP 65 remote graphic display terminal |
| Configuration | | SoMove Simple Loader, Multi-Loader | SoMove Simple Loader, Multi-Loader |
| Standards and certifications | | IEC 61800-5-1, IEC 61800-3 (environments 1 and 2, category C2), UL508C, EN 954-1 category 3, ISO/EN 13849-1/-2 category 3 (PL e), IEC 61508 (parts 1 & 2) SIL 3 level, draft standard EN 50495E, IEC 60 721-3-3 classes 3C3 and 3S2 | |
| | | CE, UL, CSA, C-Tick, NOM, GOST | |
| References | | ATV32 | ATV71 |

Related products

Operator dialogue terminals
Standard Advanced Panels
Magelis™ GT, GK, GH and GTW

| | | | | |
|-----------------------------|--|--|---|--|
| Applications | | Display of text messages, graphic objects and synoptic views Control and configuration of data | | |
| Type of terminal | | Touch screen Standard Advanced Panels | | |
| Display | |  | | |
| Type | | Backlit monochrome (amber or red mode) STN LCD (320 x 240 pixels) or TFT LCD | Backlit monochrome or colour STN LCD or backlit colour TFT LCD (320 x 240 pixels) or (640 x 480 pixels) (3) | Backlit colour STN LCD or colour TFT LCD (640 x 480 pixels) |
| Capacity | | 3.8" (monochrome or colour) | 5.7" (monochrome or colour) | 7.5" (colour) |
| Data entry | | Via touch screen | | |
| Static function keys | | - | | |
| Dynamic function keys | | - | | |
| Service keys | | - | | |
| Alphanumeric keys | | - | | |
| Memory capacity | | 32 MB Flash EPROM | | |
| Applications | | 32 MB Flash EPROM | 16 MB Flash EPROM (3) | 32 MB Flash EPROM |
| Expansion | | - | By means of 128 MB, 256 MB, 512 MB, 1 GB or 2 GB CF card (except XBTGT2110) | |
| Functions | | Limited by internal Flash EPROM memory capacity | | |
| Maximum number of pages | | Limited by capacity of internal Flash EPROM memory or CF card memory | | |
| Variables per page | | Unlimited (8000 variables max.) | | |
| Representation of variables | | Alphanumeric, bitmap, bargraph, gauge, tank, tank level indicator, curves, polygon, button, LED | | |
| Recipes | | 32 groups of 64 recipes comprising 1024 ingredients max. | | |
| Curves | | Yes, with log | | |
| Alarm logs | | Yes | | |
| Real-time clock | | Built-in | | |
| Discrete I/O | | - | 1 input (reset) and 3 outputs (alarm, buzzer, run) | |
| Multimedia I/O | | - | (3) | 1 audio input (microphone), 1 composite video input (digital or analogue video camera), 1 audio output (loudspeaker) (1) |
| Communication | | Uni-TE (2), Modbus, Modbus TCP/IP (1) and for PLC brands: Mitsubishi, Omron, Allen-Bradley and Siemens | | |
| Downloadable protocols | | RS 232C/RS 422/485 (COM1) | | |
| Asynchronous serial link | | RS 232C/RS 422/485 (COM1) | RS 232C/RS 422/485 (COM1) and RS 485 (COM2) | |
| USB ports | | 1 | 1 (3) | |
| Bus and networks | | - | Modbus Plus and Fipway with USB gateway, PROFIBUS DP and Device Net with optional card | |
| Printer link | | Ethernet TCP/IP (10BASE-T/100BASE-TX) (1) | | |
| Development software | | Vijeo Designer (on Windows XP Professional and Windows 7 Professional 32/64-bit) | | |
| Operating system | | Magelis (200 MHz RISC CPU) | | |
| Type of terminal | | XBTGT11/13 | XBTGT21/22/23/24/29 | XBTGT42/43 |

(1) Depending on model.
(2) Uni-TE version V2 for Twido controller and TSX Micro/Premium platform.
(3) For XBTGT 2430, 32 MB Flash EPROM, 1 sound output, 2 USB ports, 266 MHz RISC CPU.
(4) For XBTGT 5430.

| | | | | | |
|-----------------------------|--|--|--|---|--|
| Applications | | | Display of text messages, graphic objects and synoptic views Control and configuration of data | | |
| Type of terminal | | | Touch screen Standard Advanced Panels | | |
| Display | | |  | | |
| Type | | | Backlit colour STN LCD or colour TFT LCD (640 x 480 pixels or 800 x 600 pixels) (4) | Backlit colour TFT LCD (800 x 600 pixels) | Backlit colour TFT LCD (1024 x 768 pixels) |
| Capacity | | | 10.4" (colour) | 12.1" (colour) | 15" (colour) |
| Data entry | | | Via touch screen | | |
| Static function keys | | - | | | |
| Dynamic function keys | | - | | | |
| Service keys | | - | | | |
| Alphanumeric keys | | - | | | |
| Memory capacity | | | 32 MB Flash EPROM | | |
| Applications | | 32 MB Flash EPROM | | | |
| Expansion | | By means of 128 MB, 256 MB, 512 MB, 1 GB or 2 GB CF card | | | |
| Functions | | | Limited by capacity of internal Flash EPROM memory or CF card memory | | |
| Maximum number of pages | | Unlimited (8000 variables max.) | | | |
| Variables per page | | Alphanumeric, bitmap, bargraph, gauge, tank, tank level indicator, curves, polygon, button, LED | | | |
| Representation of variables | | 32 groups of 64 recipes comprising 1024 ingredients max. | | | |
| Recipes | | Yes, with log | | | |
| Curves | | Yes | | | |
| Alarm logs | | Built-in | | | |
| Real-time clock | | 1 input (reset) and 3 outputs (alarm, buzzer, run) | | | |
| Discrete I/O | | 1 audio input (microphone), 1 composite video input (digital or analogue video camera), 1 audio output (loudspeaker) (1) | | | |
| Multimedia I/O | | 1 audio input (microphone), 1 composite video input (digital or analogue video camera), 1 audio output (loudspeaker) (1) | | | |
| Communication | | | Uni-TE (2), Modbus, Modbus TCP/IP (1) and for PLC brands: Mitsubishi, Omron, Allen-Bradley and Siemens | | |
| Downloadable protocols | | RS 232C/RS 422/485 (COM1) and RS 485 (COM2) | | | |
| Asynchronous serial link | | 2 | | | |
| USB ports | | Modbus Plus with USB gateway | | | |
| Bus and networks | | Ethernet TCP/IP (10BASE-T/100BASE-TX) | | | |
| Printer link | | RS 232C (COM1) serial link, USB port for parallel printer | | | |
| Development software | | | Vijeo Designer (on Windows XP Professional and Windows 7 Professional 32/64-bit) | | |
| Operating system | | | Magelis (266 MHz RISC CPU) | | |
| Type of terminal | | | XBTGT52/53/54 | XBTGT63 | XBTGT73 |

(1) Depending on model.
(2) Uni-TE version V2 for Twido controller and TSX Micro/Premium platform.
(3) For XBTGT 2430, 32 MB Flash EPROM, 1 sound output, 2 USB ports, 266 MHz RISC CPU.
(4) For XBTGT 5430.

Related products

Operator dialogue terminals
Standard Advanced Panels
Magelis™ GT, GK, GH and GTW

| | | | | |
|---|-----------------------------|--|--|---------------------|
| Applications | | Display of text messages, graphic objects and synoptic views Control and configuration of data | | |
| Type of terminal | | Standard Advanced Panels with keypad | | |
|  | | | | |
| Display | Type | Colour TFT LCD (320 x 240 pixels) or monochrome STN | Colour TFT LCD (640 x 480 pixels) | |
| | Capacity | 5.7" (monochrome or colour) | 10.4" (colour) | |
| Data entry | | Via keypad and/or touch screen (configurable) and/or by industrial pointer | | |
| | Static function keys | 10 | 12 | |
| | Dynamic function keys | 14 | 18 | |
| | Service keys | 8 | | |
| | Alphanumeric keys | 12 | | |
| Memory capacity | Application | 16 MB Flash EPROM | 32 MB Flash EPROM | |
| | Expansion | By means of 128 MB, 256 MB, 512 MB, 1 GB or 2 GB CF card | | |
| Functions | Maximum number of pages | Limited by capacity of internal Flash EPROM memory or CF card memory | | |
| | Variables per page | Unlimited (8000 variables max.) | | |
| | Representation of variables | Alphanumeric, bitmap, bargraph, gauge, tank, tank level indicator, curves, polygon, button, LED | | |
| | Recipes | 32 groups of 64 recipes comprising 1024 ingredients max. | | |
| | Curves | Yes, with log | | |
| | Alarm logs | Yes | | |
| | Real-time clock | Built-in | | |
| | Discrete I/O | | | 1 input - 3 outputs |
| | Multimedia I/O | | | - |
| | Communication | Downloadable protocols | Uni-TE (2), Modbus, Modbus TCP/IP (1) and for PLC brands: Mitsubishi, Omron, Allen-Bradley and Siemens | |
| Asynchronous serial link | | RS 232C/RS 422/485 (COM1) RS 485 (COM2) | | |
| USB ports | | 1 | 2 | |
| Bus and networks | | Modbus Plus, Fipway with USB gateway, PROFIBUS DP and Device Net with optional card Ethernet TCP/IP (10BASE-T/100BASE-TX) | | |
| Printer link | | RS 232C (COM1) serial link, USB port for parallel printer | | |
| Development software | | Vijeo Designer (on Windows XP Professional and Windows 7 Professional 32/64-bit) | | |
| Operating system | | Magelis (CPU 266 MHz RISC) | | |
| Type of terminal | | XBTGK21/23 | XBTGK53 | |

(1) Depending on model.
(2) Uni-TE version V2 for Twido controller and TSX Micro/Premium platform.

| | | | |
|---|--|--|-----------------------------------|
| Display of text messages, graphic objects and synoptic views Control and configuration of data | | | |
| Portable Standard Advanced Panels | | Open touch screen Standard Advanced Panels | |
|  | | | |
| Display | Colour TFT LCD (640 x 480 pixels) | Colour TFT LCD (800 x 600 pixels) | Colour TFT LCD (800 x 600 pixels) |
| | 5.7" (colour) | 10.4" (colour) | 15" (colour) |
| Via touch screen | | Via touch screen | |
| 11 | | - | |
| - | | - | |
| - | | - | |
| - | | - | |
| 32 MB Flash EPROM | | 2 GB CF system card included with terminal, expandable to 4 GB | |
| By means of 128 MB, 256 MB, 512 MB, 1 GB or 2 GB CF card (3) | | | |
| Limited by capacity of internal Flash EPROM memory or CF card memory | | | |
| Unlimited (8000 variables max.) | | | |
| Alphanumeric, bitmap, bargraph, gauge, tank, tank level indicator, curves, polygon, button, LED | | | |
| 32 groups of 64 recipes comprising 1024 ingredients max. | | | |
| Yes, with log | | | |
| Yes | | | |
| Built-in | | | |
| - | | 1 audio output | |
| Communication | Uni-TE (2), Modbus, Modbus TCP/IP and for PLC brands: Mitsubishi, Omron, Rockwell Automation and Siemens | Uni-TE (2), Modbus, Modbus TCP/IP (1) and for PLC brands: Mitsubishi, Omron, Allen-Bradley and Siemens | |
| | RS 232C/RS 422-485 (COM1) | RS 232C (COM1) | RS 232C (COM1) |
| | 1 | 2+1 frontal | 4+1 frontal |
| | - | Modbus Plus with USB gateway | |
| | 1 Ethernet port (10BASE-T/100BASE-TX) | 2 Ethernet ports (4) (10BASE-T/100BASE-TX/1 GB) | |
| - | RS 232C (COM1) serial link, USB port for parallel printer | | |
| Vijeo Designer (on Windows XP Professional and Windows 7 Professional 32/64-bit) | | | |
| Magelis (266 MHz RISC CPU) | | Windows XP Embedded | |
| XBTGH2460/ XBTGH2460B (5) | | XBTGTW5354 | XBTGTW652 |
| | | HMIGTW7354 HMIGTW73545 (6) | |

(1) Depending on model.
(2) Uni-TE version V2 for Twido controller and TSX Micro/Premium platform.
(3) Except for HMIGTW●●● with 4 GB SD memory card.
(4) Except on XBTGTW652 with 1 Ethernet TCP/IP port (10BASE-T/100BASE-TX) and 1 Ethernet TCP/IP port (10BASE-T/100BASE-TX/1 GB).
(5) Version without Emergency stop button.
(6) Version with stainless steel front panel.

Related products

Operator dialogue terminals

Magelis™ GTO Optimum Advanced Panels

| | |
|--|---|
| Applications | Display of text messages, graphic objects and synoptic views Control and configuration of data |
| Type of terminal | Optimum Advanced Panels, touch screen |
| Degree of protection (according to IEC 60529) | IP 65 (IP 67 with addition of a cover) |

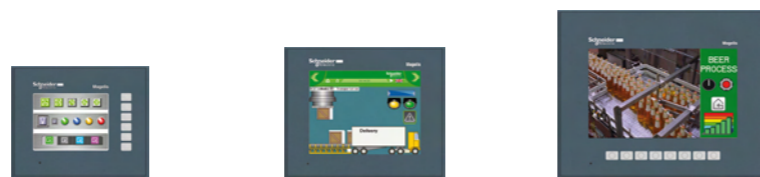

| | | | | |
|-----------------------------|-----------------------------|--|--|-------------------------------------|
| Display | Type | Color TFT LCD, backlit 320 x 240 pixels (QVGA) | Color TFT LCD, backlit 800 x 480 pixels (WVGA) | |
| | Capacity | 3.5" | 5.7" | 7.0" Wide |
| Data entry | Static function keys | Via touch screen | Via touch screen | Via touch screen |
| | Dynamic function keys | 6 function keys (static or dynamic) | – | 8 function keys (static or dynamic) |
| | Service keys | – | – | – |
| | Alphanumeric keys | – | – | – |
| | Applications | 64/96 MB Flash EPROM (1) | 96 MB Flash EPROM | |
| Functions | Expansion | – | By 4 GB SD card (except HMIGTO2300) | |
| | Maximum number of pages | Limited by internal Flash EPROM memory capacity | Limited by capacity of internal Flash EPROM memory or of SD card | |
| | Variables per page | Unlimited (8000 variables max.) | | |
| | Representation of variables | Alphanumeric, bitmap, bargraph, gauge, tank, tank level indicator, curves, polygon, button, LED | | |
| | Recipes | 32 groups of 64 recipes comprising 1024 ingredients max. | | |
| | Curves | Yes, with log | | |
| | Alarm logs | Yes | | |
| | Real-time clock | Built-in | | |
| | Discrete I/O | – | | |
| | Multimedia I/O | – | | |
| Communication | Downloadable protocols | Uni-TE (2), Modbus, Modbus TCP/IP (1) and for PLC brands: Mitsubishi, Omron, Allen-Bradley and Siemens | | |
| | Asynchronous serial link | RS 232C (COM1) and RS 485 (COM2) except HMIGTO1310: RS 232C/485 (COM1) | | |
| | USB ports | 1 type A host connector + 1 mini-B connector | | |
| | Buses and networks | Ethernet TCP/IP (10BASE-T/100BASE-TX) (3), Modbus Plus and Fipway via USB gateway | | |
| Development software | Printer link | RS 232C (COM1) serial link (4) and USB port for parallel printer | | |
| | Operating system | Vijeo Designer (on Windows XP and Windows 7) | | |
| Type of terminal | | Magelis (333 MHz RISC CPU) | | |
| | | HMIGTO1300 | HMIGTO2300 | HMIGTO3510 |
| | | HMIGTO1310 | HMIGTO2310 | |

(1) Depending on model.
 (2) Uni-TE version V2 for Twido controller and TSX Micro/Premium platform.
 (3) Except HMIGTO1300 and GTO2300 (Modbus Plus and Fipway via USB gateway only).
 (4) Except HMIGTO1310 (USB port for parallel printer only).

| | |
|--|---|
| Display of text messages, graphic objects and synoptic views Control and configuration of data | |
| Optimum Advanced Panels, touch screen | Optimum Advanced Panels, touch screen, "Stainless Steel" version |
| IP 65 (IP 67 with addition of a cover) | IP 66K (Front panel with stainless steel frame) for food & beverage environment |

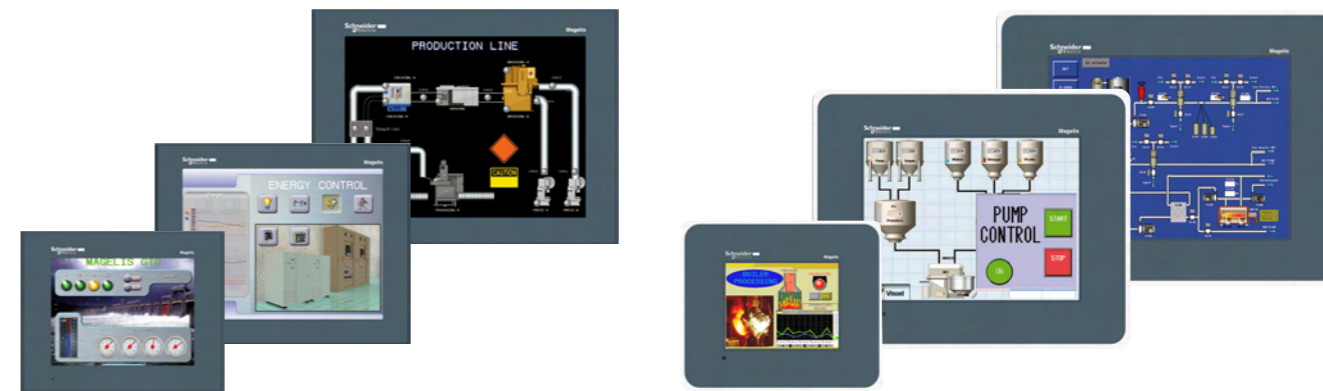

| | | | | | |
|--|--|---|---|--|---|
| Color TFT LCD, backlit 640 x 480 pixels (VGA) | Color TFT LCD, backlit 640 x 480 pixels (VGA) | Color TFT LCD, backlit 800 x 600 pixels (SVGA) | Color TFT LCD, backlit 320 x 240 pixels (QVGA) | Color TFT LCD, backlit 640 x 480 pixels (VGA) | Color TFT LCD, backlit 800 x 600 pixels (SVGA) |
| 7.5" | 10.4" | 12.1" | 5.7" | 10.4" | 12.1" |
| Via touch screen | | | | | |
| 96 MB Flash EPROM | | | | | |
| By 4 GB SD card | | | | | |
| Limited by capacity of internal Flash EPROM memory or of SD card | | | | | |
| Unlimited (8000 variables max.) | | | | | |
| Alphanumeric, bitmap, bargraph, gauge, tank, tank level indicator, curves, polygon, button, LED | | | | | |
| 32 groups of 64 recipes comprising 1024 ingredients max. | | | | | |
| Yes, with log | | | | | |
| Yes | | | | | |
| Built-in | | | | | |
| – | | | | | |
| – | | | | | |
| Uni-TE (2), Modbus, Modbus TCP/IP (1) and for PLC brands: Mitsubishi, Omron, Allen-Bradley and Siemens | | | | | |
| RS 232C (COM1) and RS 485 (COM2) | | | | | |
| 1 type A host connector + 1 mini-B connector | | | | | |
| Ethernet TCP/IP (10BASE-T/100BASE-TX), Modbus Plus and Fipway via USB gateway | | | | | |
| RS 232C (COM1) serial link and USB port for parallel printer | | | | | |
| Vijeo Designer (on Windows XP and Windows 7) | | | | | |
| Magelis (333 MHz RISC CPU) | | | | | |
| HMIGTO4310 | HMIGTO5310 | HMIGTO6310 | HMIGTO2315 | HMIGTO5315 | HMIGTO6315 |

Related products

Control and signaling units

| Type of products | Pilot lights | Pushbuttons, selector switches and pilot lights | | | Biometric switches | |
|---------------------------------------|--|---|--|---|--|-----------------------------|
| | | | | | | |
| Description of range | <ul style="list-style-type: none"> LED pilot lights | <ul style="list-style-type: none"> Pushbuttons Multiple-headed pushbuttons Emergency Stop pushbuttons Selector switches and key switches Illuminated pushbuttons Pilot lights | | | <ul style="list-style-type: none"> Fingerprint readers 24V ~ Stand-alone biometric switches Stand-alone USB biometric switches USB biometric switches dedicated to Schneider HMI (1) | |
| Features | Products | Monolithic, compact, low consumption | Complete units or sub-assemblies (body + head) | | | Monolithic |
| | Bezel | Double insulated | Double insulated (3) | Metal, chromium plated or black | Double insulated | Double insulated, dark grey |
| | Shape of head | Circular | Circular, square or rectangular | Circular | Circular or square | – |
| Drilling or cut-out for fixing | | Ø 8 mm and Ø 12 mm/0.315 in. and 0.472 in. | Ø 16 mm/0.630 in. | Ø 22 mm/0.866 in. | | |
| Degree of protection | Conforming to IEC 60529 | IP 40 IP 65 with seal | IP 65 | IP 66 IP 69K (Selector switches and key switches, multiple-headed pushbuttons and Emergency Stop pushbuttons with bellows) | IP 65 (control button) | |
| | Conforming to UL 508 and CSA C22-2 N° 14 | – | Enclosure type 4, 4X and 13 | | | Enclosure type 12 |
| Cabling | | Tags for 2.8 x 0.5 mm/0.110 x 0.020 in. connectors or threaded connector | Faston connectors Solder pins for printed circuit boards (3) Fast connector socket (4) | Spring clamp terminal connections Screw clamp terminal connections Faston connectors Connector With adaptor for printed circuit board | Cable or connectors | |
| Mounting | Panel thickness | 1...8 mm/0.039...0.315 in. | 1...6 mm/0.039...0.236 in. | | | |
| Type references | | XVLA | XB6, XB6E | XB4 | XB5 | XB5S |

(1) Compatible with Magelis iPC, STU, OT, GXO, GT (except GT1000 series), GK, GH, and GTO models.
 (2) Wireless and batteryless pushbutton and receiver ready-paired at the factory.

| Wireless and batteryless pushbuttons | Pushbuttons, selector switches and pilot lights | Joystick controllers | Pushbuttons, selector switches and pilot lights | Cam switches | | |
|---|--|---|--|--|---|---|
| | | | | | | |
| <ul style="list-style-type: none"> Wireless and batteryless pushbuttons and rope pull switch Configurable receivers Access point Relay-antenna Mobile handy box or plastic boxes for wall mounting | <ul style="list-style-type: none"> Pushbuttons Emergency Stop and Emergency switching off pushbuttons Selector switches and key switches Illuminated pushbuttons Pilot lights | <ul style="list-style-type: none"> 2 or 4 direction Stay put or spring return | <ul style="list-style-type: none"> Pushbuttons Emergency Stop buttons Selector switches and key switches Illuminated pushbuttons Pilot lights | <ul style="list-style-type: none"> Switches Stepping switches Reversing and changeover switches Ammeter switches Voltmeter switches Reversing switches Star-delta and reversing star-delta switches Pole change switches | | |
| Ready-to-use packs (2) and "components" range | Monolithic | Complete units or sub-assemblies (body + head with lever) | Complete units or sub-assemblies (body + head) | Complete units or sub-assemblies (body + front panel + head) | | |
| Metal, chromium plated or double insulated, black | Double insulated, dark grey (or white for pilot lights) | Metal, chromium plated | Double insulated, black | Metal, chromium plated or double insulated, black | | |
| Transmitter with circular head | Circular | Circular | Hexagonal | Square | | |
| Ø 22 mm/0.866 in. | | | Ø 30 mm/1.181 in. | Ø 16 or Ø 22 mm/0.630 or 0.866 in.: series K10 Ø 22 mm/0.866 in. and multifixing: series K1/K2 4 holes, 48 or 68 centres: series K30...K150 | | |
| IP 65 | IP 65 (control buttons and pilot lights) IP 54 (Emergency switching off pushbuttons) | IP 65 | IP 66 | IP 65 | IP 66 | IP 65: series K10 IP 40, IP 65 with seal: series K1/K2 IP 40: series K30...K150 |
| Enclosure type 12 | Enclosure type 3 (pushbuttons and Emergency stop) and 4 (pilot lights) | Enclosure type 4, 4X and 13 | Enclosure type 4 and 13 (9001K) Enclosure type 4, 4X, 13 (9001SK) | – | | |
| Wireless (transmitter) Through cable (receiver) | Screw and captive clamp terminal connections Faston clip connections (pilot lights) | Screw and captive clamp terminal connections | | | | |
| 1...6 mm/0.039...0.236 in. | | | | | 0.5...6 mm/0.020...0.236 in. (depending on model) | |
| XB5R, XB4R | XB7 | XD4PA | XD2GA | XD5PA | 9001K, 9001SK | K10, K1, K2, K30, K50, K63, K115, K150 |

(3) For Harmony® XB6 only.
 (4) For Harmony® XB6E only.

Related products

Control stations and enclosures

| Type of applications | All applications | | | |
|--|---|---|--|---|
| Enclosures | Plastic | | Glass-reinforced polyester | |
| | Complete stations and separate components for customer assembly | | Empty insulated enclosures | |
|  | | | | |
| Main feature | Pre-drilled control stations | | Pre-drilled or undrilled enclosures | |
| Associated control and signalling units | Harmony XB5® with plastic bezel | | Harmony® XB7, monolithic, plastic | Harmony XB4® with metal bezel Harmony XB5 with plastic bezel |
| Number of cut-outs for Ø 22 control and signalling units | 1, 2, 3, 4 or 5 | 1, 2 or 3 (complete stations) 1, 2, 3, 4 or 5 (empty enclosures) | 1, 2 or 3 | 1, 2, 4, 8 or 16 |
| Material | Polycarbonate | | ABS | Glass-reinforced polyester |
| Colour | Yellow lid Light grey base | Dark grey lid Light grey base | Light grey or yellow lid Light grey base | Coloured grey throughout |
| Degree of protection | IP 65 / NEMA Enclosure type 4, 4X and 13 | | IP 54 | IP 65 |
| Function | Emergency Stop or Emergency switching off | Start or Stop Start-Stop with pilot light Motion control | According to equipment fitted: <input type="checkbox"/> Start or Stop <input type="checkbox"/> Start-Stop with pilot light <input type="checkbox"/> Motion control <input type="checkbox"/> Emergency stop | |
| Cable entries | Knock-outs (CM12, Pg 13.5) | | Knock-outs (ISO 20) | Undrilled |
| Type references | XALK | XALD | XALE | XAPA |

| | | | Specific applications | | |
|--|--|---|--|--|-------------------------------|
| Metal | Metal front plate, insulated protective rear cover | | Plastic | | Metal |
| Empty enclosures | Empty, flush mounting enclosures: front plate + rear cover | | Control stations for severe environments | Lift inspection stations | Key operated control stations |
|  | | | | | |
| Pre-drilled enclosures | Pre-drilled or undrilled enclosures | Pre-drilled front plates & rear covers | Pre-drilled empty control stations | Pre-drilled empty enclosures or fitted stations | Fitted stations |
| Harmony XB4® with metal bezel Harmony XB5® with plastic bezel | | | Harmony XB5® with plastic bezel | Harmony XB5® or XB7® with plastic bezel | With key lock |
| 8, 16, 24, 30 or 40 | 1, 2, 3, 4, 6, 8 or 12 | 1, 2, 3, 4 or 5 | 1, 2, 3, 4 or 5 | 1, 2, 3, 4, 5 or 6 with or without power socket | – |
| Aluminium alloy or sheet steel | Zinc or aluminium alloy | Front plate: brushed aluminium Rear cover: polystyrene | Mineral reinforced polyamide | Polycarbonate | Zinc alloy |
| Blue lid and base | XAP M: Blue lid Blue base XAP J: Yellow lid Blue base | Unpainted aluminium | Black lid Black base | Yellow lid Light grey base | Grey |
| IP 54 | IP 65 | | IP 66 IP 69K | IP 44 (with power socket) IP 55 or IP 66 depending on model | IP 54 |
| According to equipment fitted: <input type="checkbox"/> Start or Stop <input type="checkbox"/> Start-Stop with pilot light <input type="checkbox"/> Motion control <input type="checkbox"/> Emergency stop | | | | | Start-Stop |
| <input type="checkbox"/> Tapped entries for cable-glands <input type="checkbox"/> or undrilled | Tapped entries for cable-glands | Knock-outs (with protective rear cover) | Two ISO 20 open entries | <input type="checkbox"/> Knock-outs (CM12, Pg 13.5) <input type="checkbox"/> or undrilled | Tapped for cable-glands |
| XB2SL | XAPM, XAPJ | XAPE | XALG | XALF | XAPS |

Related products

Protection components
TeSys T Motor Management System

Applications

Multifunction motor and machine protection

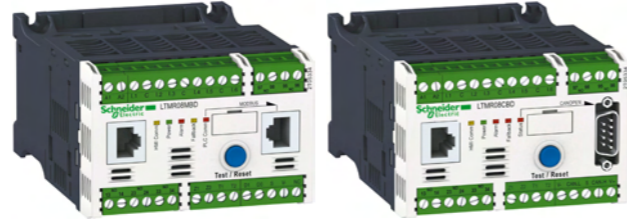

Device type

Controllers

For network/bus

| | | | | |
|--------|---------|-----------|-------------|-----------------|
| Modbus | CANopen | DeviceNet | Profibus DP | Ethernet TCP/IP |
|--------|---------|-----------|-------------|-----------------|

Current range

0.4...100 A (with internal current transformer)
100...810 A (with external current transformer)

Control voltage

24 V
~ 100...240 V

Number of I/O

6 inputs
4 outputs

Measurements

- Current between phases
- Earth fault.
- Motor temperature.

Functions

Protection and monitoring functions:

- thermal overload,
- motor temperature monitoring,
- phase imbalance and phase failure,
- locked rotor,
- long starting times,
- phase reversal,
- earth fault.

Device type

| | | | | |
|-----------|-----------|-----------|-----------|-----------|
| LTMR●●M●● | LTMR●●C●● | LTMR●●D●● | LTMR●●P●● | LTMR●●E●● |
|-----------|-----------|-----------|-----------|-----------|

Input extension modules, for all LTM R controllers

–

–

| | |
|----------|-------------------|
| 24 V (1) | ~ 100...240 V (1) |
|----------|-------------------|

4 independent inputs

Voltage between phases

Monitoring functions:

- voltage,
- power,
- Cos φ (power factor)

LTMEV40BD

LTMEV40FM

Operator control unit

–

–

Powered via the LTM R controller or via the LTM E extension module.

–

–

Display functions:

- measurements,
- faults and alarms,
- statistics, etc...

LTM CU

(1) Input control voltage. The electronics are powered via the controller.

Related Products

Motor starter solutions with 1, 2 or 3 products

| Advantages | <ul style="list-style-type: none"> Simple manual motor starter Fast wiring Compacity | <ul style="list-style-type: none"> Conventional solution for pushbutton or automated motor control Easy maintenance (contactor replacement) Broad offer (e.g. connections, motor rating...) | <ul style="list-style-type: none"> Advanced motor protection thanks to dedicated components Easy maintenance (selective replacement) Broad offer (e.g. protection type...) | |
|--|---|--|--|--|
| Separate components | <p>1 product solution</p> <p>Motor circuit breaker</p> <p>GV2 GV3 GV7</p> <p>Up to 110 kW</p> | <p>2 products solution</p> <p>Motor circuit breaker</p> <p>GV2 GV3 GV7</p> <p>+ Contactor</p> <p>LC1 K LC1 D LC1 F and LC1 B</p> <p>Up to 110 kW</p> | <p>3 products solution</p> <p>Magnetic circuit breaker</p> <p>GV2 GV3 Compact NSX</p> <p>+ Contactor</p> <p>LC1 K LC1 D LC1 F and LC1 B</p> <p>+ Thermal relay Controller</p> <p>LRD LTM LUTM</p> <p>LR2K LUTM</p> <p>Up to 110 kW</p> | <p>Switch-disconnector fuse</p> <p>GS2</p> <p>+ Contactor</p> <p>LC1 K LC1 D LC1 F and LC1 B</p> <p>+ Thermal relay Controller</p> <p>LRD LTM LUTM</p> <p>LR2K LUTM</p> <p>Up to 560 kW</p> |
| Pre-assembled: Ready to incorporate in the panel | | <p>Pre-assembled: Ready to incorporate</p> <p>Pre-assembled motor circuit breaker + contactor</p> <p>Up to 15 kW GV2ME...K1... GV2DP</p> | | |

| Enclosed: Ready to mount on the machine | <p>Enclosed: Ready to mount</p> <p>VOF VCFN VOFY</p> <p>GV2MC GV2MP GV2PC GV3PC</p> <p>Up to 45 kW Up to 30 kW</p> | <p>Enclosed: Ready to mount</p> <p>GV2ME LE1D</p> <p>Up to 37 kW</p> |
|---|--|--|
|---|--|--|

All in one: TeSys U

Control unit

Up to 33 kW LUB12, LUB32

Basic to extended functionalities

- Short circuit, overload protection.
- Overload indication and alarming.
- Status, remote control via communication bus.

Advantages

- Fast wiring.
- Compact motor starter.
- Flexibility: last minute customization.
- Full electrical coordination.

Compliant standards

Legend of symbols

| | | |
|---|--|------------------|
| Switch-disconnector | Fuse switch-disconnector | Thermal relay |
| Circuit breaker with short-circuit protection | Circuit breaker with short-circuit and overload protection | Relay, contactor |

Solink integration system into PLC architecture

LAD5C... LUFC00...

Easy connection of motor starters to PLC

- RJ45 cables to PLC IO modules.
- LAD5C...: RJ45 connection module for GV + LC1D assembly.
- LUFC00...: RJ45 connection module for LUB...

NEW

Related Products

Short-circuit and overload protection

| | | | |
|--------------|---|---|--|
| Applications | DC circuit protection and disconnection: DC power supplies, generators, batteries, etc. | AC circuit protection and disconnection of machines, electrical distribution in buildings | |
|--------------|---|---|--|



| Description | | Miniature circuit-breaker | | Miniature circuit-breaker | | Miniature circuit-breaker | | Miniature circuit-breaker | |
|-----------------|------------------------------------|---------------------------|-----------------|---------------------------|--------------|---------------------------|--|---------------------------|--|
| Characteristics | Voltage | 60 V DC/pole | 250 V DC/pole | 230 / 400 V AC | | | | | |
| | Number of poles | 1 or 2 | | 1, 2, 3 and 4 | | | | | |
| | Nominal current (A) | 1 to 63 | | 63 to 125 | | | | | |
| | Breaking capacity (kA) | 6 | | 10 | | | | | |
| | Type of loads / Tripping curve (1) | B, C, D | C | B, C, D | | | | | |
| | Width | 18 mm/pole | | 27 mm/pole | | | | | |
| | Product reference | IEC | Acti 9 iC60N | Acti 9 C60H-DC | Acti 9 iC60N | Acti 9 C120N | | | |
| | IEC/UL | Multi 9 C60N | Multi 9 C60H-DC | Multi 9 C60N | – | | | | |

(1) Tripping curve:
 B (3 In < Im < 5 In) standard.
 C (5 In < Im < 10 In) inrush current.
 D (10 In < Im < 14 In) electronics or long cable length.

| | | | | |
|---|--|--|--|--|
| Protection and disconnection of electrical circuits | Protection of operators against electrical shocks in event of direct or indirect contact with live equipment | Protection of operators against electrical shocks in event of direct or indirect contact with live equipment | Protection of operators against electrical shocks in event of direct or indirect contact with live equipment | Protection of sensitive equipments against voltage surges due to lightning, high power switching, etc. |
|---|--|--|--|--|



| Fuse holder | | RCBO (3) | | RCBO (3) | | RCCB (4) | | Surge arrester | |
|-------------|------------|------------------------|-------------|-----------------------------|-------------|------------------------|--------------|----------------|--|
| 500 V AC | 690 V AC | 230/400 V AC | | | | | | | |
| – | | 1P+N | 2, 3 and 4P | | | | | | |
| 25 | 32 | 50 | 25 | 6 to 32 | 25 to 63 | | – | | |
| 8 x 32 mm | 10 x 38 mm | 14 x 51 mm | 22 x 58 mm | | | | | | |
| 20 | 120 | – | | – | – | – | 20 | | |
| – | | C class A 30 or 300 mA | | C class A 30 or 300 mA | | C class A 30 or 300 mA | | Type 2 | |
| – | | 36 mm | 27 to 63 mm | | 36 to 72 mm | | 72 to 120 mm | | |
| – | | Acti 9 DPN Vigi | | Acti 9 Vigi iC60 blocks (2) | | Acti 9 RCCB ID | | Quick PRD 20r | |
| DF8 | DF10 | DF14 | DF22 | – | | Multi9 GFP | | – | |

Related Products

Incoming protection and switching

| Applications | | On-load switching of motors, resistive and inductive loads | Control and disconnection of electrical distribution circuits |
|------------------------------|---|---|--|
| | | TeSys Vario | Compact |
| | |  |  |
| Description | | Switch disconnectors Rotary switch with fully visible breaking | Switch disconnectors |
| Isolation and Disconnection | | <input checked="" type="checkbox"/> | |
| Protection | | - | |
| Characteristics | Rated operational current (A) | 12 to 175 | 40 to 2500 |
| | Number of poles | 3 to 6 | 3 and 4 |
| | Short-circuit making capacity at 400 V I _{cm} (kA) | 0.5 to 3 | 50 to 220 |
| | Product name | V | INS |
| | Embedded metering | - | - |
| Standards and certifications | | IEC 60947-3 UL508 | IEC 60947-3 UL508 |

| Protection and switching of motors | Protection in industrial and tertiary applications | Feeder protection and circuit disconnection for multistandard motor circuit design | Power circuit protection and disconnection in industrial, infrastructure and building applications |
|---|---|---|--|
| TeSys GS | NG | Powerpact | Compact |
|  |  |  |  |
| Switch fuse disconnectors | Circuit-breakers | Moulded case circuit-breakers with optional integrated communication and metering possibilities | |
| <input checked="" type="checkbox"/> | <input checked="" type="checkbox"/> | | |
| <input checked="" type="checkbox"/> | <input checked="" type="checkbox"/> | | |
| 32 to 1250 | 10 to 125 | 15 to 600 | 16 to 3200 |
| 3 and 4 | | | |
| 5 to 90 | 10 to 50 | 18 to 65 | 25 to 150 |
| GS | NG125 | NH, NJ, NL | NSX/NS |
| - | - | Micrologic metering adapters | |
| IEC 60947-3 | IEC 60947-2 | IEC 60947-2 UL508 | IEC 60947-2 |

Related Products

Indication and metering

| Applications | Current transformers | Basic meters | |
|--------------|---|--|---|
| | Current sensor: the current value is converted into a 0 to 5 A scale. To be used with ammeter, power meter, energy metering | Display of simple electrical values, volts or amps Meters for mounting on DIN rails | Display of simple electrical values, volts or amps Meters for mounting on front panels |

CT iVLT iAMP VLT AMP



| Description | | Current transformers | Voltmeter Ammeter | Voltmeter Ammeter |
|------------------------|----------------------|--|-------------------------------------|---------------------------------------|
| Electrical indications | | – | I / U | I / U |
| Characteristics | Measurement accuracy | Class 0.5 to 3 | Class 1.5 | Class 1.5 |
| | Installation | On conductor (cable, bar..) Double terminal blocks on type D provide alternative cabling possibility | DIN rail 4 x 18 mm modules | Flush mounted 72 x 72 mm / 96 x 96 mm |
| | Voltage measurement | Maximum rated operational voltage: 720 V AC | VLT: 500 V AC direct or external VT | VLT: 500 V AC direct or external VT |
| | Current measurement | Ranges from 40/5 A to 6000/5 A | AMP: 30 A direct or external CT | AMP: external CT |
| | Communication ports | – | – | – |
| | Inputs / Outputs | – | – | – |
| | Memory capacity | – | – | – |

Select switches for ammeter and voltmeter

• Din Rail panel mounted 48x48

| Basic energy meters | | | Basic multi-function metering | | | |
|---|--|--|--|--|---|--|
| Recording and display of energy consumption The meters are mounted on a DIN rail | | | Simple indication of the current passing through a Compact NSX circuit-breaker | Full indication of electrical values and energy metering of a circuit protected by a Compact NSX circuit-breaker | Full indication of electrical values and energy metering of a circuit | |

iEM2000 iME1 iEM3000 Series Micrologic A trip unit Micrologic E trip unit PM3200 PM5100
iEM2010 PM3210 PM5300
iEM200T PM3250 PM5500
PM3255



| Kilowatt-hour meters | Kilowatt-hour meters | Kilowatt-hour meters | Ammeter | Power meter | Metering & sub-metering Class 0.5S IEC 62053-22 Class 1 IEC 62053-21 Class 2IEC 62053-23 | Metering & sub-metering Class 0.5S IEC 62053-22 Class 0.2S (PM55●●) IEC 62053-22 Class 1/2 IEC 62053-24 |
|-----------------------------------|----------------------|----------------------|---|---|--|---|
| E | | | I | I, U, F, P, Q, S, PF, E | I, U, F, P, Q, S, PF, E (Power demand and current demand) | I, U, F, P, Q, S, PF, E (Power demand and current demand) |
| Class 1 | | | Current: class 1 | Current: class 1 Voltage: 0.5% Power: class 2 | Class 0.5 | Class 0.2S (PM55●●) Class 0.5S |
| DIN rail 1.2 or 4 x 18 mm modules | | | Embedded into circuit-breaker. Remote LCD display available | Embedded into circuit-breaker, remote LCD display available | DIN rail | Flush mounted 96 mm x 96 mm |
| 400 V AC direct | | | | 690 V AC | 50 V to 330 V AC (Ph-N) 80 V to 570 V AC (Ph-Ph) up to 1 MV AC (ext. VT) | 20 V L-N / 35 V L-L to 277 V L-N / 480 V L-L / 600 V L-L (PM55●●) |
| 40 to 63 A direct or external CT | | | 0.2 x In 1.2 x In of circuit-breaker | 0.2 x In 1.2 x In of circuit-breaker | External CT | External CT |
| – | | | 1 | 1 | 1 | 2 |
| – | | | – | – | – | 4 I/O 6 I/O (PM55●●) |
| – | | | – | – | – | 256 KB 1.1 MB (PM55●●) |

StruxureWare Power Monitoring Expert

- Real-time data viewing and sharing via smart dashboards
- Intuitive data formats to customize views
- Historical trending of any measurement
- Alarm and event notification and logging
- Comprehensive reporting

Related Products

Power distribution and connection systems

| | | |
|---------------------|---|---|
| Applications | Power busbars | Device feeders |
| | This power busbar system is designed for distributing the power vertically to device feeders or as a horizontal device feeder for circuit-breakers, motor controllers, etc. | These device feeder systems are designed for feeding the power to modular and non-modular protection device on single or multiple DIN rail rows |

Linergy BZ Linergy FH Linergy FT Linergy FM Linergy HK

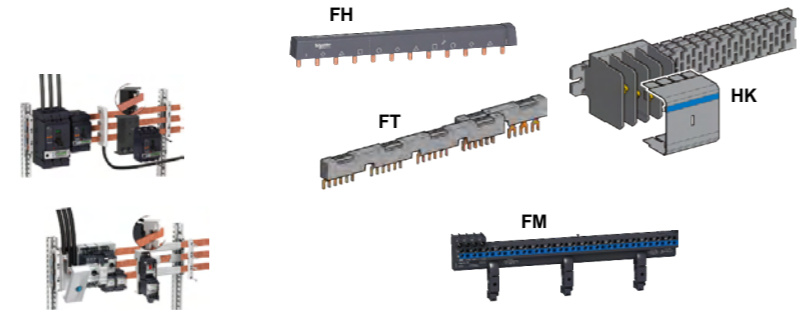

| | | | | |
|--------------------|---|--|---|---|
| Description | 630 A/60 mm busbar system for connection of circuit-breakers, contactors, motor controllers, etc. using a range of snap-on mounting plates and snap-on cable connectors | Insulated comb busbars, with accessories | Insulated busbars, with spring connectors and accessories | Insulated busbars, with plug-in pre-wired connectors and mounting plates, accessories |
| | Suitable for both horizontal and vertical power distribution | FT simplifies cabling of TeSys motor starters FH is specifically for Acti 9 miniature circuit-breakers, even when lateral auxiliaries are mounted | Quick connection simplifies phase balancing | Hot-plug: Safely plug-in and unplug live connectors |

| | | | | | | |
|-------------------------------------|---------------------------------------|----------|-------------|---------------|-------|----------|
| Characteristics | Rating | 630 A | 63 to 100 A | 63, 80, 160 A | 160 A | |
| | Connection technology | – | – | – | – | |
| | Cabling range (mm²) | – | – | – | – | |
| Standards and certifications | | IEC - UL | IEC | IEC - UL | IEC | IEC - UL |

| | | | | | | |
|----------------------------|---|--|--|--|--|--|
| Distribution blocks | Terminal blocks | | | | | |
| | The wired power distribution is a flexible solution for feeding various components when their electrical connections are on multiple levels | | | Screw, spring and push-in modular terminal blocks and earth/neutral bars offer a universal solution when a reliable and simple connection is needed in distribution and control panel boards | | |

Linergy DX Linergy DS Linergy BS Linergy TRV Linergy TRR Linergy TRP Linergy TB



| | | | | | | | |
|---------------------------------------|--|--|---|--|---------------------------------|-----------------------------|------------------------------|
| Description | Quick distribution block, for flexible or rigid cables | Single and four pole multistage distribution blocks | Multistage distribution blocks | Common range of accessories | Common range of accessories | Common range of accessories | Various lengths, accessories |
| | Installation on rail (63 A) or mounting plate (125, 160 A) | Lateral upstream cable terminals for easier connection. Installation on DIN rail or mounting plate | Plain or threaded holes in copper bars Cabling accessories Horizontal or vertical mounting. | Copper bars with plain or threaded holes | For extra reliable connections | Single-handed installation | |
| Rating | 63, 125, 160 A | 100, 125, 160, 250 A | 160, 250, 400, 630 A | Up to 309 A (IEC), 300 A (UL-CSA) | Up to 76 A (IEC), 85 A (UL-CSA) | Up to 20 A (IEC-UL-CSA) | – |
| Connection technology | Spring | Screw | Screw | Screw | Spring | Push-in | Spring/screw |
| Cabling range (mm²) | 6 to 16 | 1.5 to 120 | M6 holes, 16 to 50 mm ² | 0.18 to 150 | 0.16 to 16 | 2.5, 4 | 2.5 to 16 |
| Standards and certifications | IEC | IEC | IEC | IEC - UL | IEC - UL | IEC - UL | IEC |

Steel enclosures

Wall-mounting



- S3D Wall-mounting enclosures
- S3DEX Potentially explosive atmospheres
- S3DM Distribution modular enclosures

Most common pumping architectures can be protected by Wall Mounting enclosures Spacial S3D, especially in indoor applications.

Characteristics

- From 300 x 200 mm to 1400 x 1000 mm
- Up to IP66
- Up to IK10

Options

Large choice of enclosure versions and accessories.

Why should I choose it?

Durable, with high UV resistance, coated hinges, aluminium hinge pins and folded gutters that avoids the entry of water, oil and other liquids.

Floor-standing



- SM Floor-standing compact
- SF Floor-standing modular

For more equipment and heavy loads, pumping solutions can be installed in robust sheet metal compact enclosures (Spacial SM) or modular enclosures (Spacial SF). Up to 600 different possible configurations. Spacial SF is also available in kit version.

Characteristics

- From 500 x 500 mm to 2200 x 1800 mm
- IP55
- Up to IK10

Options

Large choice of enclosure versions and accessories.

Why should I choose it?

High level of modularity and flexibility. Save up 25 % of time in assembly.

Outdoor



- S3HD Wall-mounting Heavy Duty enclosures
- SFHD Floor-standing Heavy Duty enclosures

New

Spacial S3HD and SFHD are engineered to resist aggressive environments (anti-corrosion certification class C4 H, ISO 12.944).

Characteristics

- From 300 x 200 mm to 2000 x 800 mm
- Up to IP66
- IK10

Options

Ventilated plinths, roof ventilation module, slim fanbox, Heavy Duty fixings.

Why should I choose it?

Designed to resist in outdoor private areas.

ClimaSys

Thermal management

CV-CA Ventilation/Airing

CU Cooling Units

CE Exchangers

CR Resistance Heaters

CC Thermal Control

New

New

Accessories

Mounting

Power distribution

Cable management

New

Details and technical datasheets available on www.schneider-electric.com

Insulating material enclosures

Wall-mounting Thalassa insulating enclosures are made of Polyester which avoids any electrical contact risks.

Characteristics

- From 430 x 330 mm to 1050 x 850 mm
- Up to IP66
- Up to IK10

Options

Plinths, cable entries, mounting accessories and thermal management devices, as for other enclosures.



- PLM Wall-mounting polyester
- PLMEX Potentially explosive atmospheres

Why should I choose it?

Thalassa PLM ensure a long-life lasting without maintenance.

Thalassa PLA are floor-standing enclosures with a large choice of dimensions and combinations, for pumping solution in harsh environments where corrosion has to be taken in account.

Characteristics

- From 500 x 500 mm to 1500 x 1250 mm
- Up to IP65
- Up to IK10

Options

A variety of versions (completely sealed, open bottom, with or without canopy), mounting accessories and thermal management devices.



- PLA Floor-standing polyester enclosures
- PLD Floor-standing DIN polyester enclosures

Why should I choose it?

Thalassa PLA protect large and heavy control equipment.

New

Thalassa PHD has multiple virtues:

- pressure and shock resistant (IEC 61439-5),
- anti-posting thanks to its special front door,
- insulated (Class II).

Characteristics

- From 500 x 500 mm to 2000 x 750 mm
- Up to IP65
- IK10

Options

Anti-burglary accessory, ventilated plinths, roof ventilation module, slim fanbox.

Why should I choose it?

Suitable for harsh environments in outdoor public areas.



- PHD polyester Heavy Duty enclosures

Project & Services



Configured offer
Adapted services: cut-outs, painting, assemblies...



Specific offer
The co-development service tailor-made for you

Spare Parts



softwares



Spacial.pro
Graphic configurator



Digital Rules
Enclosures selector



Spacial.conf
Services configurator



ProClima
Thermal calculation software

chapter 9

Index

■ Product reference index

□ Product reference index 9/2

| | | | | | | | | | |
|--------------|------|----------------|------|----------------|------|------------------|------|---------------|------|
| 490NAD91103 | 4/3 | ABFT20E050 | 2/21 | SOMBASAP10 | 5/11 | TCSCCTN023F13M03 | 4/13 | TCSXCN1M1F1E | 4/35 |
| 490NAD91104 | 4/3 | | 2/96 | SOMNACCZXEPAZZ | 5/5 | | 4/20 | TCSXCN1M1F2E | 4/35 |
| 490NAD91105 | 4/3 | ABFT20E100 | 2/21 | SOMNACCZXSPAZZ | 5/5 | TCSCCTN026M16M | 4/13 | TCSXCN1M1F03E | 4/35 |
| 490NTC00005 | 4/49 | | 2/96 | SOMNACCZXTPAZZ | 5/5 | | 4/20 | TCSXCN1M1F5E | 4/35 |
| 490NTC00005U | 4/49 | ABFT20E200 | 2/21 | SOMNACS41 | 5/5 | TCSECE3M3M1S4 | 4/47 | TCSXCN1M1F10E | 4/35 |
| 490NTC00015 | 4/49 | | 2/96 | SOMNADCZXEPAZZ | 5/5 | TCSECE3M3M2S4 | 4/47 | TCSXCN1M1F15E | 4/35 |
| 490NTC00040 | 4/49 | ABFTE20EP100 | 3/13 | SOMNADCZXSPAZZ | 5/5 | TCSECE3M3M3S4 | 4/47 | TCSXCN1M2SA | 4/35 |
| 490NTC00040U | 4/49 | ABFTE20EP200 | 3/13 | SOMNADCZXTPAZZ | 5/5 | TCSECE3M3M5S4 | 4/47 | TCSXCN1M5SA | 4/35 |
| 490NTC00080 | 4/49 | ABFTE20EP300 | 3/13 | SOMNSDCZXTPAZZ | 5/5 | TCSECE3M3M10S4 | 4/47 | TCSXCN1M15SA | 4/35 |
| 490NTC00080U | 4/49 | ABFTE20SP100 | 3/13 | STBNDP2212 | 4/3 | TCSECL1M3M1S2 | 4/49 | TCSXCN1MNX1E | 4/35 |
| 490NTW00002 | 4/47 | ABFTE20SP200 | 3/13 | | | TCSECL1M3M3S2 | 4/49 | TCSXCN1MNX3E | 4/35 |
| | 4/49 | ABFTE20SP300 | 3/13 | | | TCSECL1M3M5S2 | 4/49 | TCSXCN1MNX10E | 4/35 |
| 490NTW00002U | 4/47 | ABL8BBU24200 | 8/26 | T | | TCSECL1M3M10S2 | 4/49 | TCSXCN1MNX25E | 4/35 |
| | 4/49 | ABL8BUF24400 | 8/26 | TCSCAR01NM120 | 4/13 | TCSECL1M3M25S2 | 4/49 | TCSXCN2FNX1E | 4/34 |
| | | | | | 4/20 | TCSECL1M3M40S2 | 4/49 | TCSXCN2FNX3E | 4/34 |
| 490NTW00005 | 4/47 | ABL8PRP24100 | 8/26 | TCSCAR013M120 | 4/13 | TCSECN300R2 | 4/47 | TCSXCN2FNX10E | 4/34 |
| | 4/49 | ABL8RED24400 | 8/26 | | 4/20 | | 4/48 | TCSXCN2FNX25E | 4/34 |
| 490NTW00005U | 4/47 | AM02CA001V000 | 4/21 | TCSCCN1FNX1SA | 4/34 | TCSECU3M3M1S4 | 4/47 | TCSXCN2M2F1E | 4/35 |
| | 4/49 | | 4/39 | TCSCCN1FNX3SA | 4/34 | TCSECU3M3M2S4 | 4/47 | TCSXCN2M2F2E | 4/35 |
| 490NTW00012 | 4/47 | B | | TCSCCN1FNX10SA | 4/34 | TCSECU3M3M3S4 | 4/47 | TCSXCN2M2F03E | 4/35 |
| | 4/49 | BMXXCAUSBH018 | 2/20 | TCSCCN1FNX25SA | 4/34 | TCSECU3M3M5S4 | 4/47 | TCSXCN2M2F5E | 4/35 |
| 490NTW00012U | 4/47 | | 2/31 | TCSCCN1M1F1 | 4/34 | TCSECU3M3M10S4 | 4/47 | TCSXCN2M2F10E | 4/35 |
| | 4/49 | | 2/41 | TCSCCN1M1F2 | 4/34 | TCSEK1MDRS | 4/48 | TCSXCN2M2F15E | 4/35 |
| 490NTW00040 | 4/47 | | 2/85 | TCSCCN1M1F03 | 4/34 | TCSEK3MDS | 4/47 | TCSXCN2M2SA | 4/35 |
| | 4/49 | | | TCSCCN1M1F5 | 4/34 | | 4/48 | TCSXCN2M5SA | 4/35 |
| 490NTW00040U | 4/47 | F | | TCSCCN1M1F10 | 4/34 | TCSESM043F1CS0 | 4/49 | TCSXCN2M15SA | 4/35 |
| | 4/49 | FTXCN12F5 | 4/20 | TCSCCN1M1F15 | 4/34 | TCSESM043F1CU0 | 4/49 | TCSXCN2MNX1E | 4/35 |
| 490NTW00080 | 4/47 | FTXCN12M5 | 4/20 | TCSCCN1MNX1SA | 4/34 | TCSESM043F2CS0 | 4/49 | TCSXCN2MNX3E | 4/35 |
| | 4/49 | FTXES01 | 4/19 | TCSCCN1MNX3SA | 4/34 | TCSESM043F2CU0 | 4/49 | TCSXCN2MNX10E | 4/35 |
| 490NTW00080U | 4/47 | | | TCSCCN1MNX10SA | 4/34 | TCSESM083F1CS0 | 4/49 | TCSXCN2MNX25E | 4/35 |
| | 4/49 | | | TCSCCN1MNX25SA | 4/34 | TCSESM083F1CU0 | 4/49 | TCSXCNAMUM3P | 2/20 |
| 499NEH10410 | 4/49 | HMISCU6A5 | 2/85 | TCSCCN2FNX1SA | 4/34 | TCSESM083F2CS0 | 4/49 | | 2/31 |
| 499NES18100 | 4/49 | HMISCU6B5 | 2/85 | TCSCCN2FNX3SA | 4/34 | TCSESM083F2CU0 | 4/49 | | 2/41 |
| 499NMS25101 | 4/49 | HMISCU8A5 | 2/85 | TCSCCN2FNX10SA | 4/34 | TCSESM083F23F0 | 4/49 | | 2/51 |
| 499NMS25102 | 4/49 | HMISCU8B5 | 2/85 | TCSCCN2FNX25SA | 4/34 | | | | 2/63 |
| 499NSS25101 | 4/49 | HMIZSDIO | 2/85 | TCSCCN2M2F1 | 4/34 | TCSESU033FN0 | 4/47 | | 2/75 |
| 499NSS25102 | 4/49 | HMIZSUKIT | 2/85 | TCSCCN2M2F2 | 4/34 | | 4/49 | | 5/11 |
| | | HMIZSURDP | 2/85 | TCSCCN2M2F03 | 4/34 | TCSESU043F1N0 | 4/47 | TCSXCNDFNX1V | 4/35 |
| | | HMIZSURDP5 | 2/85 | TCSCCN2M2F5 | 4/34 | TCSESU043FN0 | 4/49 | TCSXCNDFNX3V | 4/35 |
| | | HMIZSUSBB | 2/85 | TCSCCN2M2F10 | 4/34 | TCSESU051F0 | 4/49 | TCSXCNDFNX10V | 4/35 |
| A | | L | | TCSCCN2M2F15 | 4/34 | TCSESU053FN0 | 4/47 | TCSXCNDFNX25V | 4/35 |
| ABE7B20MPN20 | 2/96 | LMC058LF42 | 2/62 | TCSCCN2MNX1SA | 4/34 | | 4/49 | TCSXCNDMDF1V | 4/35 |
| ABE7B20MPN22 | 2/96 | LMC058LF424 | 2/62 | TCSCCN2MNX3SA | 4/34 | TCSMCN3M4F3C2 | 2/51 | TCSXCNDMDF2V | 4/35 |
| ABE7B20MRM20 | 2/96 | LMC078CECS20T | 2/69 | TCSCCN2MNX10SA | 4/34 | | 2/63 | TCSXCNDMDF03V | 4/35 |
| ABE7BV20 | 2/96 | LU9GC3 | 4/5 | TCSCCN2MNX25SA | 4/34 | | 4/5 | TCSXCNDMDF5V | 4/35 |
| ABE7BV20TB | 2/96 | | | TCSCCN4F3M1T | 4/13 | | 4/7 | TCSXCNDMDF10V | 4/35 |
| ABE7E16EPN20 | 2/21 | | | | 4/21 | | 4/9 | TCSXCNDMDF15V | 4/35 |
| | 2/96 | | | | 4/39 | | | TCSXCNDMNX1V | 4/35 |
| ABE7E16SPN20 | 2/21 | O | | TCSCCN4F3M05T | 4/13 | TCSXCN1FNX1E | 4/34 | TCSXCNDMNX3V | 4/35 |
| | 2/96 | OTB1C0DM9LP | 4/19 | | 4/21 | TCSXCN1FNX3E | 4/34 | TCSXCNDMNX10V | 4/35 |
| ABE7E16SRM20 | 2/21 | OTB1S0DM9LP | 4/19 | | 4/39 | TCSXCN1FNX10E | 4/34 | TCSXCNDMNX25V | 4/35 |
| | 2/96 | OTB9ZZ61JP | 4/19 | | 4/39 | TCSXCN1FNX25E | 4/34 | TCSXCNEFNX1V | 4/35 |
| ABE7FU012 | 2/96 | S | | TCSCCTN011M11F | 4/21 | | | TCSXCNEFNX3V | 4/35 |
| ABE7FU030 | 2/96 | SOMAAECZXSPAZZ | 5/5 | | 4/39 | | | TCSXCNEFNX10V | 4/35 |
| ABE7FU100 | 2/96 | SOMAAECZXTPAZZ | 5/5 | | 4/39 | | | | |
| ABE7FU200 | 2/96 | | | | | | | | |
| ABFC20R200 | 2/97 | | | | | | | | |

| | | | | | | | | | |
|---------------|------|------------|------|--------------|------|--------------|------|---------------|------|
| TCSXCNEFNX25V | 4/35 | TM3AI2H | 3/29 | TM3TM3G | 3/29 | TM5ACTB06 | 3/45 | TM5SAI4LK | 3/63 |
| TCSXCNEMEF1V | 4/35 | TM3AI2HG | 3/29 | TM3XREC1 | 3/37 | | 3/49 | TM5SAI4PH | 3/53 |
| TCSXCNEMEF2V | 4/35 | TM3AI4 | 3/29 | TM3XTRA1 | 3/37 | | 3/53 | TM5SAI6TH | 3/53 |
| TCSXCNEMEF03V | 4/35 | TM3AI4G | 3/29 | TM3XTYS4 | 3/31 | TM5ACTB12 | 3/41 | TM5SAO2H | 3/53 |
| TCSXCNEMEF5V | 4/35 | TM3AI8 | 3/29 | TM4ES4 | 4/41 | | 3/45 | TM5SAO2L | 3/53 |
| TCSXCNEMEF10V | 4/35 | TM3AI8G | 3/29 | TM4PDPS1 | 4/41 | | 3/49 | TM5SAO4H | 3/53 |
| TCSXCNEMEF15V | 4/35 | TM3AM6 | 3/29 | TM5ACADL100 | 3/62 | | 3/53 | TM5SAO4L | 3/53 |
| TCSXCNEYNX1V | 4/35 | TM3AM6G | 3/29 | | 4/27 | | 3/57 | TM5SAO4LK | 3/63 |
| TCSXCNEYNX3V | 4/35 | TM3AQ2 | 3/29 | TM5ACBM01R | 3/59 | | 3/61 | TM5SBER2 | 3/61 |
| TCSXCNEYNX10V | 4/35 | TM3AQ2G | 3/29 | | 3/61 | TM5ACTB12PS | 3/59 | TM5SBET1 | 3/61 |
| TCSXCNEYNX25V | 4/35 | TM3AQ4 | 3/29 | TM5ACBM01R10 | 3/59 | | 3/61 | TM5SBET7 | 3/61 |
| TCSXCNNXNX100 | 3/61 | TM3AQ4G | 3/29 | | 3/61 | | 4/27 | TM5SD000 | 3/49 |
| TLACDCBA005 | 4/13 | TM3DI8 | 3/25 | TM5ACBM05R | 3/59 | TM5ACTB16 | 3/45 | TM5SDI000 | 3/49 |
| | 4/21 | TM3DI8A | 3/25 | | 3/61 | TM5ACTB32 | 3/47 | TM5SDI2A | 3/47 |
| | 4/39 | TM3DI8G | 3/25 | TM5ACBM05R10 | 3/59 | TM5ACTB0610 | 3/45 | TM5SDI2D | 3/45 |
| TLACDCBA015 | 4/13 | TM3DI16 | 3/25 | | 3/61 | | 3/49 | TM5SDI2DF | 3/57 |
| | 4/21 | TM3DI16G | 3/25 | TM5ACBM11 | 3/45 | | 3/53 | TM5SDI4A | 3/47 |
| | 4/39 | TM3DI16K | 3/25 | | 3/49 | | 3/61 | TM5SDI4D | 3/45 |
| TLACDCBA030 | 4/13 | TM3DI32K | 3/25 | | 3/53 | TM5ACTB1210 | 3/41 | TM5SDI6D | 3/45 |
| | 4/21 | TM3DM8R | 3/25 | TM5ACBM12 | 3/47 | | 3/45 | TM5SDI6U | 3/47 |
| | 4/39 | TM3DM8RG | 3/25 | TM5ACBM15 | 3/45 | | 3/49 | TM5SDI12D | 3/45 |
| TLACDCBA50 | 4/13 | TM3DM24R | 3/25 | | 3/49 | TM5ACTB3210 | 3/47 | TM5SDI12DK | 3/63 |
| TLACDCBA050 | 4/21 | TM3DM24RG | 3/25 | TM5ACBM15 | 3/45 | | 3/53 | TM5SDI16D | 3/45 |
| | 4/39 | TM3DQ8R | 3/25 | | 3/53 | TM5ACTCH100 | 2/51 | TM5SDM12DT | 3/45 |
| TM2ALM3LT | 3/17 | TM3DQ8RG | 3/25 | | 3/57 | | 2/63 | TM5SDO2R | 3/47 |
| TM2AMI2HT | 3/17 | TM3DQ8T | 3/25 | TM5ACBM1110 | 3/45 | | 3/62 | TM5SDO2S | 3/47 |
| TM2AMI2LT | 3/17 | TM3DQ8TG | 3/25 | | 3/49 | | 4/27 | TM5SDO2T | 3/45 |
| TM2AMI4LT | 3/17 | TM3DQ8U | 3/25 | | 3/53 | TM5ACTLC100 | 2/51 | TM5SDO4R | 3/47 |
| TM2AMI8HT | 3/17 | TM3DQ8UG | 3/25 | | 3/57 | | 2/63 | TM5SDO4R4 | 3/47 |
| TM2AMM3HT | 3/17 | TM3DQ16R | 3/25 | | 3/61 | | 3/62 | TM5SDO4RK | 3/63 |
| TM2AMM6HT | 3/17 | TM3DQ16RG | 3/25 | TM5ACBM1210 | 3/47 | TM5ACTLS100 | 2/51 | TM5SDO4T | 3/45 |
| TM2AMO1HT | 3/17 | TM3DQ16T | 3/25 | | 3/49 | | 2/63 | TM5SDO4TA | 3/45 |
| TM2ARI8HT | 3/17 | TM3DQ16TG | 3/25 | TM5ACBM1510 | 3/45 | | 3/62 | TM5SDO6T | 3/45 |
| TM2ARI8LRJ | 3/17 | TM3DQ16TK | 3/25 | | 3/53 | | 4/27 | TM5SDO8TA | 3/45 |
| TM2ARI8LT | 3/17 | TM3DQ16U | 3/25 | | 3/57 | TM5C12D6T6L | 3/41 | TM5SDO12T | 3/45 |
| TM2AVO2HT | 3/17 | TM3DQ16UG | 3/25 | TM5ACBN1 | 4/27 | | 3/41 | TM5SDO12TK | 3/63 |
| TM2DAI8DT | 3/12 | TM3DQ16UK | 3/25 | TM5ACLITB1 | 2/51 | TM5C24D12R | 3/41 | TM5SDO16T | 3/45 |
| TM2DDI8DT | 3/12 | TM3DQ32TK | 3/25 | | 2/63 | TM5C24D18T | 3/41 | TM5SE1IC01024 | 3/57 |
| TM2DDI16DK | 3/12 | TM3DQ32UK | 3/25 | | 3/62 | TM5CAI8O8CL | 3/41 | TM5SE1IC02505 | 3/57 |
| TM2DDI16DT | 3/12 | TM3SAC5R | 3/35 | TM5ACLITR1 | 2/51 | TM5CAI8O8CVL | 3/41 | TM5SE1SC10005 | 3/57 |
| TM2DDI32DK | 3/12 | TM3SAC5RG | 3/35 | | 2/63 | TM5CAI8O8VL | 3/41 | TM5SE2IC01024 | 3/57 |
| TM2DDO8TT | 3/12 | TM3SAF5R | 3/35 | | 4/27 | TM5NCO1 | 4/27 | TM5SMM6D2L | 3/45 |
| TM2DDO8UT | 3/12 | TM3SAF5RG | 3/35 | TM5ACLITW1 | 2/51 | TM5NCO1K | 4/27 | TM5SPDD12F | 3/49 |
| TM2DDO16TK | 3/12 | TM3SAFL5R | 3/35 | | 2/63 | TM5PCDPS | 4/3 | TM5SPDG5D4F | 3/49 |
| TM2DDO16UK | 3/12 | TM3SAFL5RG | 3/35 | | 3/62 | TM5PCRS2 | 4/11 | TM5SPDG6D6F | 3/49 |
| TM2DDO32TK | 3/12 | TM3SAK6R | 3/35 | TM5ACLPL10 | 3/62 | TM5PCRS4 | 4/11 | TM5SPDG12F | 3/49 |
| TM2DDO32UK | 3/12 | TM3SAK6RG | 3/35 | | 4/27 | TM5SAI2H | 3/53 | TM5SPS1 | 3/59 |
| TM2DMM8DRT | 3/12 | TM3TI4 | 3/29 | TM5ACLPR10 | 3/62 | TM5SAI2L | 3/53 | TM5SPS1F | 3/59 |
| TM2DMM24DRF | 3/12 | TM3TI4G | 3/29 | | 4/27 | TM5SAI2PH | 3/53 | TM5SPS2 | 3/59 |
| TM2DRA8RT | 3/12 | TM3TI8T | 3/29 | TM5ACL1 | 2/51 | TM5SAI2TH | 3/53 | TM5SPS2F | 3/59 |
| TM2DRA16RT | 3/12 | TM3TI8TG | 3/29 | | 2/63 | TM5SAI4H | 3/53 | TM5SPS3 | 4/27 |
| TM2XMTGB | 3/17 | TM3TM3 | 3/29 | | 3/62 | TM5SAI4HK | 3/63 | TM7ACCA | 4/37 |
| | 3/19 | | | | 4/27 | TM5SAI4L | 3/53 | TM7ACCB | 4/37 |
| | 3/29 | | | | | | | | |
| | 3/53 | | | | | | | | |

| | | | | | | | | | |
|---------------|------|---------------|------|--------------|------|----------------|------|----------------|------|
| TM7ACMP | 4/37 | TM221ME32TK | 2/19 | TMC2SL1 | 2/18 | TSXCANKCDF180T | 4/13 | TWDXMT5 | 3/13 |
| TM7ACMP10 | 4/37 | TM241C24R | 2/30 | TMC2TI2 | 2/18 | | 4/20 | | 3/17 |
| TM7ACTHA | 4/36 | TM241C24T | 2/30 | TMC4AI2 | 2/30 | | 4/38 | | 3/19 |
| TM7ACTLA | 4/36 | TM241C24U | 2/30 | TMC4AQ2 | 2/30 | TSXCANKCDF90T | 4/13 | | 3/53 |
| TM7ACTW | 4/37 | TM241C40R | 2/30 | TMC4HOIS01 | 2/30 | | 4/20 | | 4/19 |
| TM7ACYC | 4/36 | TM241C40T | 2/30 | TMC4PACK01 | 2/30 | | 4/38 | | |
| TM7ACYCJ | 4/36 | TM241C40U | 2/30 | TMC4TI2 | 2/30 | TSXCANKCDF90TP | 4/13 | V | |
| TM7BAI4CLA | 3/72 | TM241CE24R | 2/30 | TMH2GDB | 2/20 | | 4/20 | VDIP184546005 | 3/37 |
| TM7BAI4PLA | 3/72 | TM241CE24T | 2/30 | TSXCANCA50 | 4/13 | | 4/38 | VDIP184546010 | 3/37 |
| TM7BAI4TLA | 3/72 | TM241CE24U | 2/30 | | 4/21 | TSXCANTDM4 | 4/13 | VDIP184546020 | 3/37 |
| TM7BAI4VLA | 3/72 | TM241CE40R | 2/30 | | 4/39 | | 4/20 | VDIP184546030 | 3/37 |
| TM7BAM4CLA | 3/72 | TM241CE40T | 2/30 | TSXCANCA100 | 4/13 | | 4/38 | VDIP184546050 | 3/37 |
| TM7BAM4VLA | 3/72 | TM241CE40U | 2/30 | | 4/21 | TSXCSA100 | 4/5 | VW3A3521 | 2/75 |
| TM7BAO4CLA | 3/72 | TM241CE40U | 2/30 | | 4/39 | | 4/7 | VW3A8306D30 | 4/5 |
| TM7BAO4VLA | 3/72 | TM241CEC24R | 2/30 | TSXCANCA300 | 4/13 | | 4/9 | | 4/7 |
| TM7BDI8B | 3/69 | TM241CEC24T | 2/30 | | 4/21 | TSXCSA200 | 4/5 | | 4/9 |
| TM7BDI16A | 3/69 | TM241CEC24U | 2/30 | TSXCANCADD03 | 4/13 | | 4/7 | VW3A8306R03 | 4/5 |
| TM7BDI16B | 3/69 | TM251MESC | 2/41 | | 4/21 | | 4/9 | | 4/7 |
| TM7BDM8B | 3/69 | TM251MESE | 2/41 | TSXCANCADD1 | 4/13 | TSXCSA500 | 4/7 | | 4/9 |
| TM7BDM16A | 3/69 | TM258LD42DT | 2/50 | | 4/39 | | 4/9 | VW3A8306R10 | 4/5 |
| TM7BDM16B | 3/69 | TM258LD42DT4L | 2/50 | | 4/21 | | 4/5 | | 4/7 |
| TM7BDO8TAB | 3/69 | TM258LF42DR | 2/50 | TSXCANCADD3 | 4/13 | TSXCX100 | 4/9 | | 4/9 |
| TM7NCOM08B | 4/33 | TM258LF42DT | 2/50 | | 4/39 | TSXPBSCA100 | 4/3 | VW3A8306R30 | 4/7 |
| TM7NCOM16A | 4/33 | TM258LF42DT4L | 2/50 | TSXCANCADD5 | 4/13 | TSXPBSCA400 | 4/3 | | 4/9 |
| TM7NCOM16B | 4/33 | TM258LF66DT4L | 2/50 | | 4/39 | TSXSACA50 | 4/5 | | 4/5 |
| TM7SPS1A | 3/73 | TMACBL1 | 2/20 | TSXCANCADD5 | 4/13 | | 4/7 | VW3A8306RC | 4/5 |
| TM200HSC206DF | 3/19 | TMAM2 | 2/20 | | 4/21 | TWDFCN2K20 | 2/97 | | 4/7 |
| TM200HSC206DT | 3/19 | | 3/25 | TSXCANCB100 | 4/13 | | 3/13 | VW3A8306TF03 | 4/5 |
| TM200RSRCEMC | 3/17 | | 3/29 | | 4/21 | TWDFCN2K26 | 2/97 | | 4/9 |
| | 3/29 | | 3/35 | TSXCANCB300 | 4/13 | | 3/13 | VW3A8306TF10 | 4/5 |
| | 3/53 | | 3/37 | | 4/21 | TWDFCW30K | 2/21 | | 4/7 |
| TM221C16R | 2/18 | TMASD1 | 2/20 | TSXCANCB50 | 4/13 | | 2/97 | | 4/9 |
| TM221C16T | 2/18 | | 2/30 | | 4/21 | TWDFCW50K | 2/21 | VW3CANA71 | 4/13 |
| TM221C24R | 2/18 | | 2/41 | TSXCANCBDD03 | 4/13 | | 2/97 | | 4/21 |
| TM221C24T | 2/18 | TMASD2 | 2/69 | | 4/39 | | 3/13 | VW3CANCARR03 | 4/13 |
| TM221C40R | 2/18 | TMAT2CSET | 2/20 | TSXCANCBDD1 | 4/13 | TWDFTB2T10 | 2/97 | | 4/21 |
| TM221C40T | 2/18 | TMAT2MSET | 2/20 | | 4/21 | TWDFTB2T11 | 2/97 | VW3CANCARR1 | 4/13 |
| TM221CE16R | 2/18 | | 3/25 | | 4/39 | TWDXCAFD010 | 4/9 | | 4/39 |
| TM221CE16T | 2/18 | TMAT2MSETG | 2/20 | | 4/21 | TWDXCAFJ010 | 4/5 | | 4/39 |
| TM221CE24R | 2/18 | | 3/25 | TSXCANCBDD3 | 4/13 | | 4/7 | VW3CANKCDF180T | 4/21 |
| TM221CE24T | 2/18 | | 3/29 | | 4/21 | | 4/9 | | 4/39 |
| TM221CE40R | 2/18 | TMAT2PSET | 2/20 | | 4/39 | TWDXCAISO | 4/5 | VW3CANTAP2 | 4/13 |
| TM221CE40T | 2/18 | | 2/31 | TSXCANCBDD5 | 4/13 | | 4/6 | | 4/20 |
| TM221M16R | 2/19 | | 2/41 | | 4/21 | | 4/9 | | 4/38 |
| TM221M16RG | 2/19 | | 3/37 | TSXCANCD100 | 4/13 | TWDXCARJ003 | 4/9 | VW3E5001R005 | 2/69 |
| TM221M16T | 2/19 | TMAT2PSETG | 3/37 | | 4/39 | TWDXCARJ010 | 4/9 | VW3E5001R010 | 2/69 |
| TM221M16TG | 2/19 | TMAT4CSET | 2/31 | | 4/39 | TWDXCARJ030 | 4/9 | VW3E5001R015 | 2/69 |
| TM221M32TK | 2/19 | TMC2AI2 | 2/18 | TSXCANCD300 | 4/13 | TWDXCARJP03 | 4/9 | VW3E5001R020 | 2/69 |
| TM221ME16R | 2/19 | TMC2AQ2C | 2/18 | | 4/21 | TWDXCARJP03P | 4/9 | VW3E5001R030 | 2/69 |
| TM221ME16RG | 2/19 | TMC2AQ2V | 2/18 | | 4/39 | | 4/9 | VW3E5001R050 | 2/69 |
| TM221ME16T | 2/19 | TMC2CONV01 | 2/18 | TSXCANCD50 | 4/13 | TWDXCAT3RJ | 4/5 | VW3E5001R100 | 2/69 |
| TM221ME16TG | 2/19 | TMC2HOIS01 | 2/18 | | 4/21 | | 4/6 | VW3E5001R150 | 2/69 |
| | | TMC2PACK01 | 2/18 | | 4/39 | | 4/9 | VW3E5001R200 | 2/69 |

| | | | |
|---------------|------|----------|------|
| VW3E5001R250 | 2/69 | XGSZ24 | 4/5 |
| VW3E5001R300 | 2/69 | | 4/7 |
| VW3E5001R400 | 2/69 | | 4/9 |
| VW3E5001R500 | 2/69 | Z | |
| VW3E704000000 | 2/69 | ZB5AZ901 | 2/85 |
| VW3E704100000 | 2/69 | ZB5AZ905 | 2/85 |
| VW3M3805R010 | 4/13 | | |
| | 4/21 | | |
| | 4/39 | | |
| VW3M3805R030 | 4/13 | | |
| | 4/21 | | |
| VW3M4701 | 2/63 | | |
| X | | | |
| XBTZ9980 | 2/51 | | |
| | 2/63 | | |
| XBTZG61 | 2/85 | | |
| XBTZG62 | 2/85 | | |
| XBTGC1100T | 2/92 | | |
| XBTGC1100U | 2/92 | | |
| XBTGC2120T | 2/92 | | |
| XBTGC2120U | 2/92 | | |
| XBTGC2230T | 2/92 | | |
| XBTGC2230U | 2/92 | | |
| XBTZ9008 | 4/5 | | |
| | 4/7 | | |
| | 4/9 | | |
| XBTZ938 | 2/51 | | |
| | 2/63 | | |
| | 4/5 | | |
| | 4/7 | | |
| | 4/9 | | |
| XBTZ9980 | 4/5 | | |
| | 4/7 | | |
| | 4/9 | | |
| XBTZ9982 | 4/5 | | |
| | 4/7 | | |
| XBTZG51 | 2/92 | | |
| XBTZG52 | 2/92 | | |
| XBTZG60 | 2/92 | | |
| XBTZG62 | 2/92 | | |
| XBTZG935 | 2/92 | | |
| XBTZGABE1 | 2/96 | | |
| XBTZGABE2 | 2/96 | | |
| XBTZGCANM | 4/17 | | |
| XBTZGCCAN | 4/17 | | |
| XBTZGCCAN | 2/92 | | |
| XBTZGCHOK | 2/92 | | |
| XBTZGCLP2 | 2/92 | | |
| XBTZGCLP4 | 2/92 | | |
| XBTZGDIO1 | 2/92 | | |
| XBTZGDIO2 | 2/92 | | |
| XBTZGFIX | 2/92 | | |
| XBTZGPWS1 | 2/92 | | |
| XBTZGUSB | 2/85 | | |
| | 2/92 | | |
| XBTZGUSBB | 2/92 | | |

Schneider Electric Industries SAS

Head Office
35, rue Joseph Monier
F-92500 Rueil-Malmaison
France



www.schneider-electric.com

The information provided in this documentation contains general descriptions and/or technical characteristics of the performance of the products contained herein. This documentation is not intended as a substitute for and is not to be used for determining suitability or reliability of these products for specific user applications. It is the duty of any such user or integrator to perform the appropriate and complete risk analysis, evaluation and testing of the products with respect to the relevant specific application or use thereof. Neither Schneider Electric nor any of its affiliates or subsidiaries shall be responsible or liable for misuse of the information contained herein.

Design: Schneider Electric
Photos: Schneider Electric

MKTED2140202EN