

EasyPact MVS

User manual
09/2022

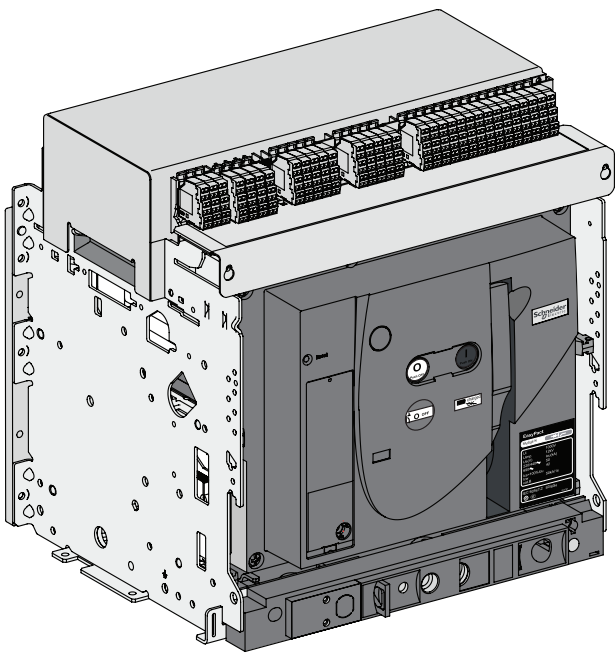



Discovering EasyPact MVS	1
Using EasyPact MVS	10
Understanding the controls and indications	10
Charging the circuit breaker	11
Closing the circuit breaker	12
Opening the circuit breaker	13
Resetting after a fault trip	13
Locking the controls	14
Using the EasyPact MVS drawout chassis	16
Identifying the circuit breaker positions	16
Racking	18
Locking the switchboard door	23
Locking the circuit breaker in disconnected position	25
Locking the circuit breaker in all positions	29
Locking the safety shutters	30
Discovering ET/ETA/ETV Trip System	32
Identifying ET/ETA/ETV Trip System designations	32
Presentation	33
Overview of current protection functions	34
Presentation	35
Overview of fault indications & Testing functions	36
Measurements- ETA & ETV	37
Setting ET/ETA/ETV Trip System	40
Setting procedure	40
Setting ET/ETA/ETV 2I Trip System	41
Setting ET/ETA/ETV 5S Trip System	42
Setting ET/ETA/ETV 6G Trip System	43
Selecting the type of neutral protection	44
Fault and status indications	45
Resetting the fault indications and checking battery status	45
Testing the ground-fault functions	46
Menus for ETA Trip System	47
Accessing the menus	47
Measuring phase currents	48
Resetting the maximum current values	49
Viewing the settings of ETA Trip System	50
Menus for ETV Trip System	51
HMI display modes	51
Quick View mode	53
Presentation	53
Use	54
Customisation	55
Tree Navigation mode	56
Presentation	56
ETV menu display	57
Displaying total active energy	58
Resetting current maximeters	59
Displaying the trip history	60
Displaying the protection settings	61
ETV set-up	62

Optional functions	66
Optional M2C contacts	66
Communication option	67
Technical appendix	69
Tripping curves	69
Zone selective interlocking (ZSI)	71
Digital display	72
Thermal memory	73
Calculating demand values	74
Identifying the electrical auxiliaries	75
Identification of the connection terminals	75
Electrical diagrams	77
Operation of electric auxiliaries	80
Discovering EasyPact MVS accessories	82
Indication contacts	82
Auxiliaries for remote operation	84
Device mechanical accessories	86
Chassis mechanical accessories	88
Inspecting and testing before use	92
Initial tests	92
What to do when the circuit breaker trips	93
Maintaining EasyPact MVS performance	94
Recommended maintenance program	94
Maintenance operations	95
Ordering replacement parts	97
Troubleshooting and solutions	99
Checking EasyPact MVS operation conditions	101

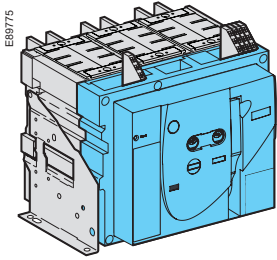

The **EasyPact MVS** range of circuit breakers and switch-disconnectors offer current ratings from 630 A to 4000 A.

Rating plate

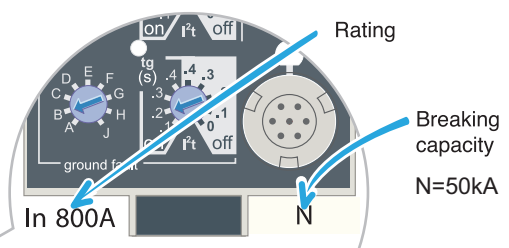
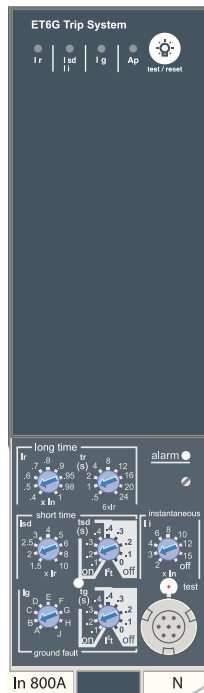
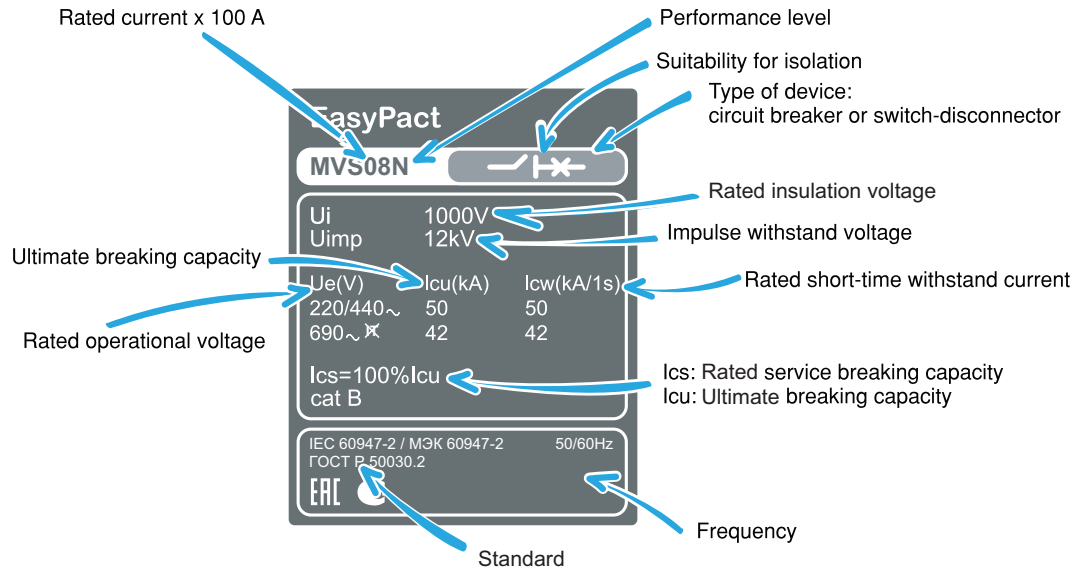

EasyPact MVS circuit breakers are available in drawout and fixed versions. The drawout version is mounted on a chassis and the fixed version is installed using fixing brackets.

Drawout version MVS 06-16 (C)

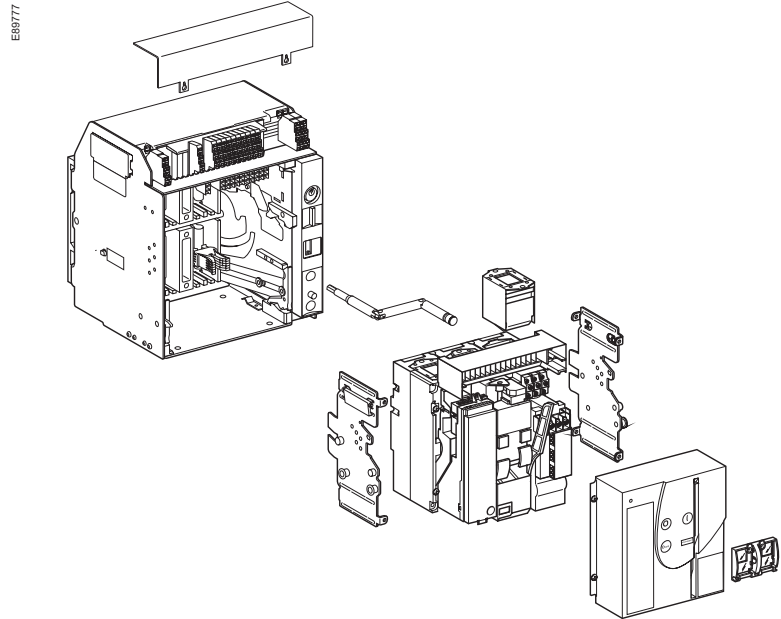

Fixed version MVS 06-16 (C)

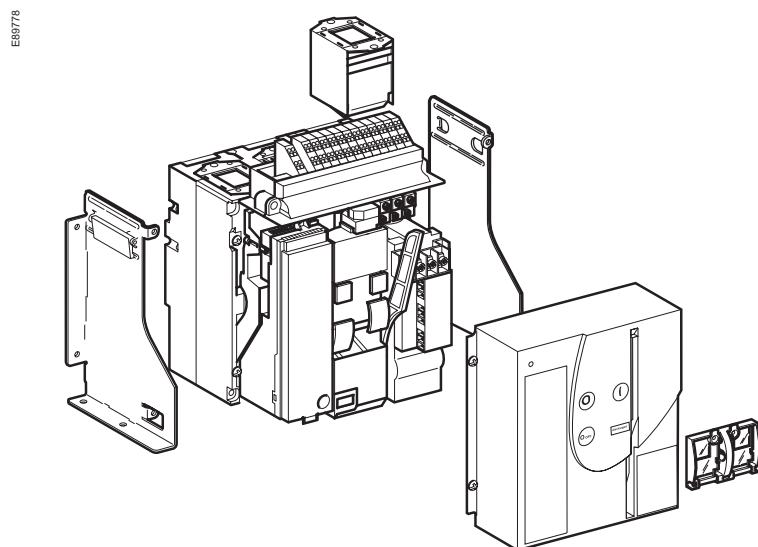

EasyPact MVS circuit breakers are available in drawout and fixed versions. The drawout version is mounted on a chassis and the fixed version is installed using fixing brackets.

Drawout version MVS 08-40 (N/H/T)

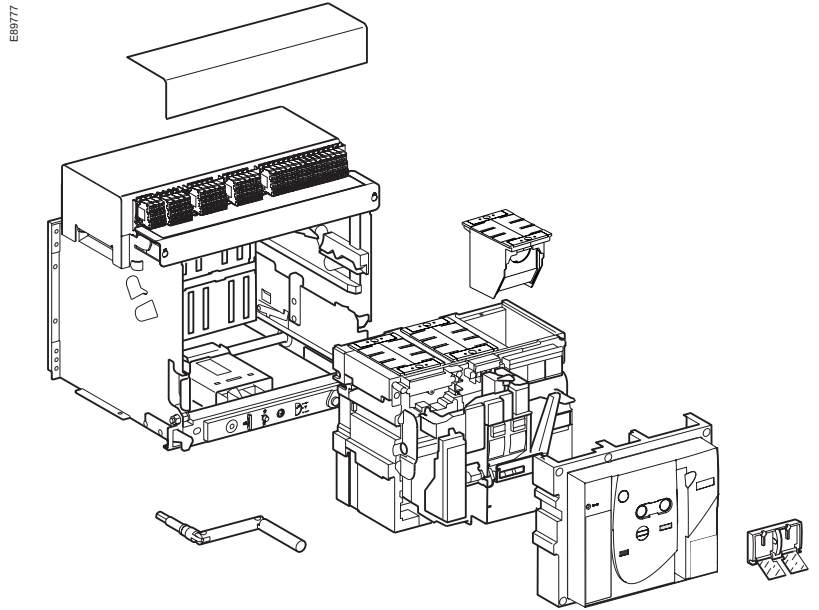

Fixed version MVS 08-40 (N/H/T)

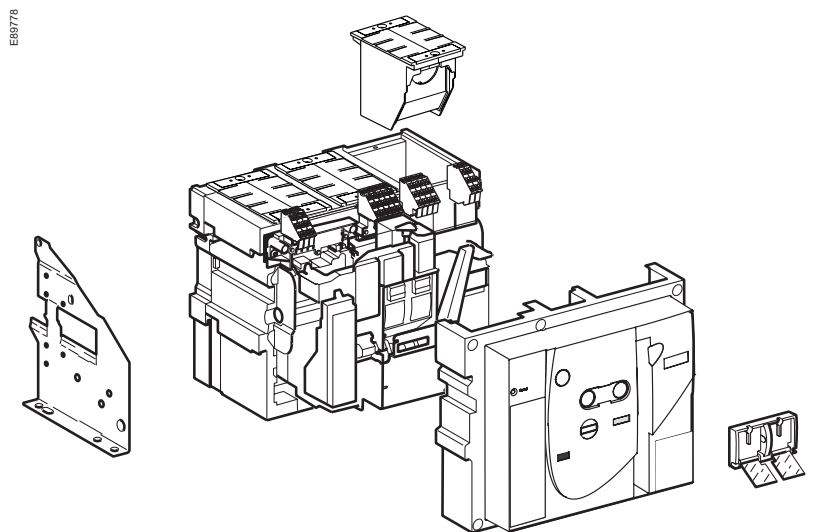

Chassis MVS 06-16 (C)

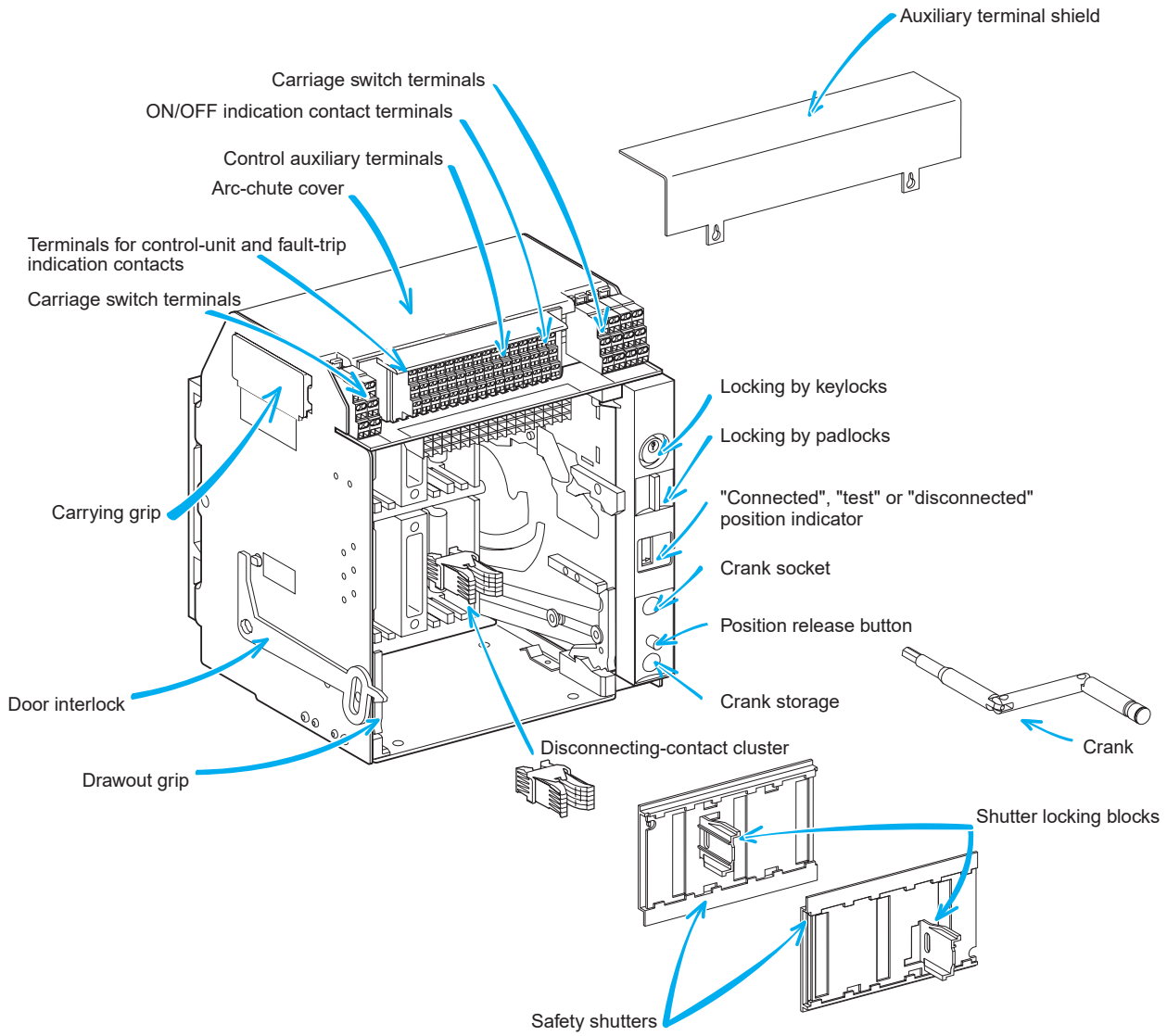

Chassis MVS 08-40 (N/H/T)

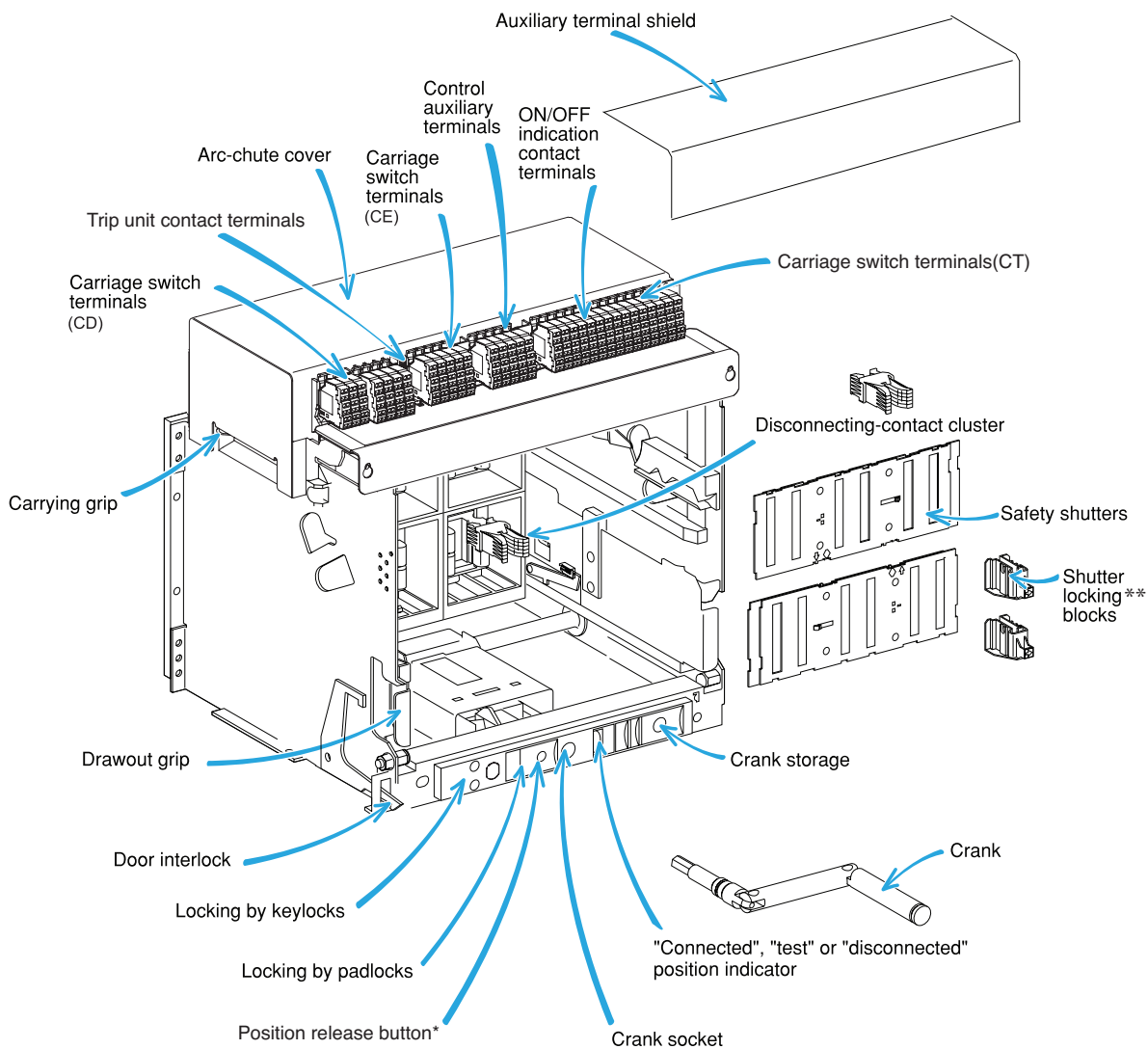

* During racking-in or racking-out operation of circuit breaker an automatic racking lock button pops out at every distinct position - "Connected", "Test" and "Disconnected". This lock indicates that exact position of the breaker is achieved and blocks operation of the crank. Make sure that the position release button, is pushed-in before rotating the crank.

** Optional device- Not supplied as standard.

Drawout Circuit breaker / switch-disconnector MVS 06-16 (C)

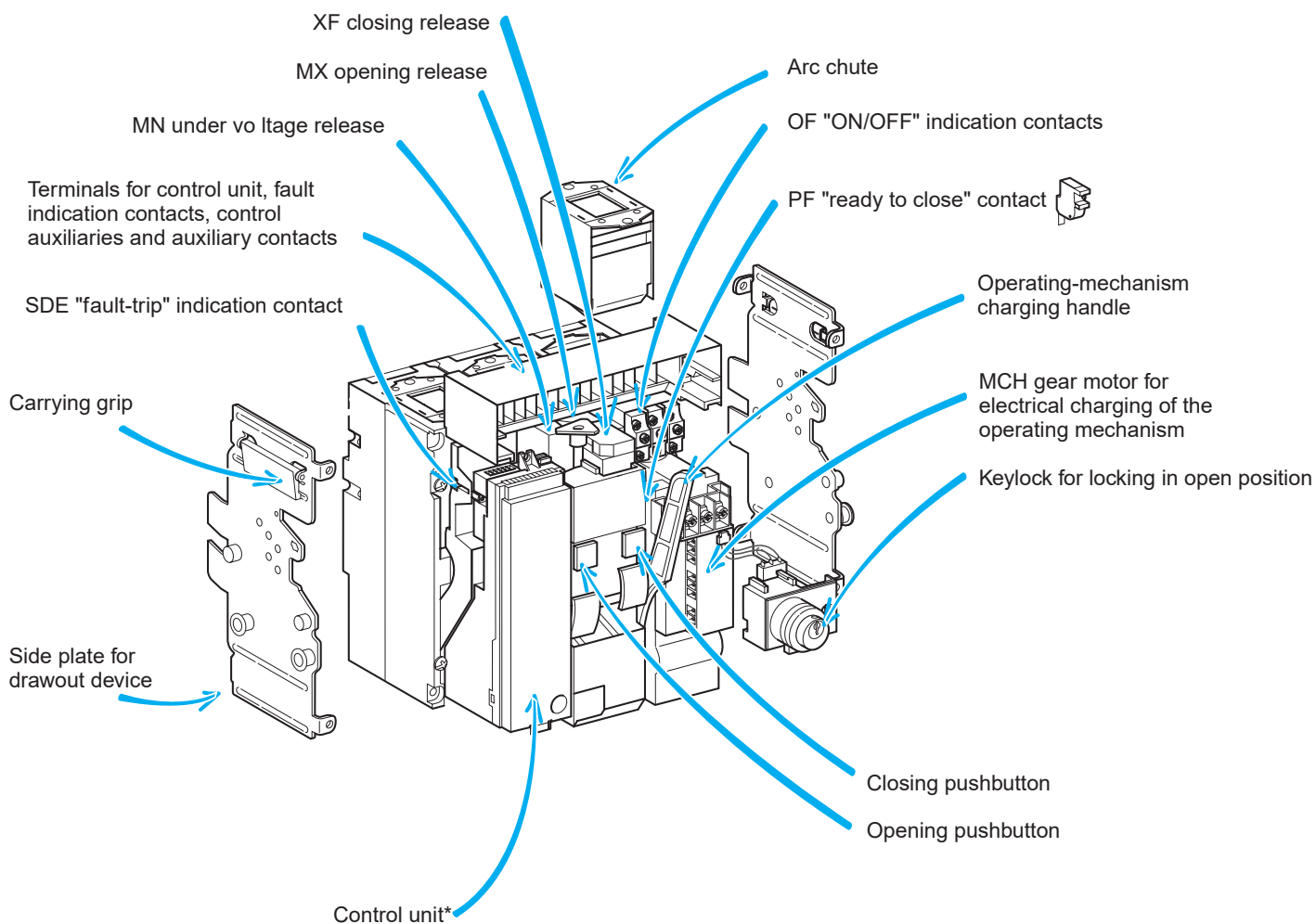

*Switch-disconnector is supplied without trip unit.

Fixed Circuit breaker / switch-disconnector MVS 06-16 (C)

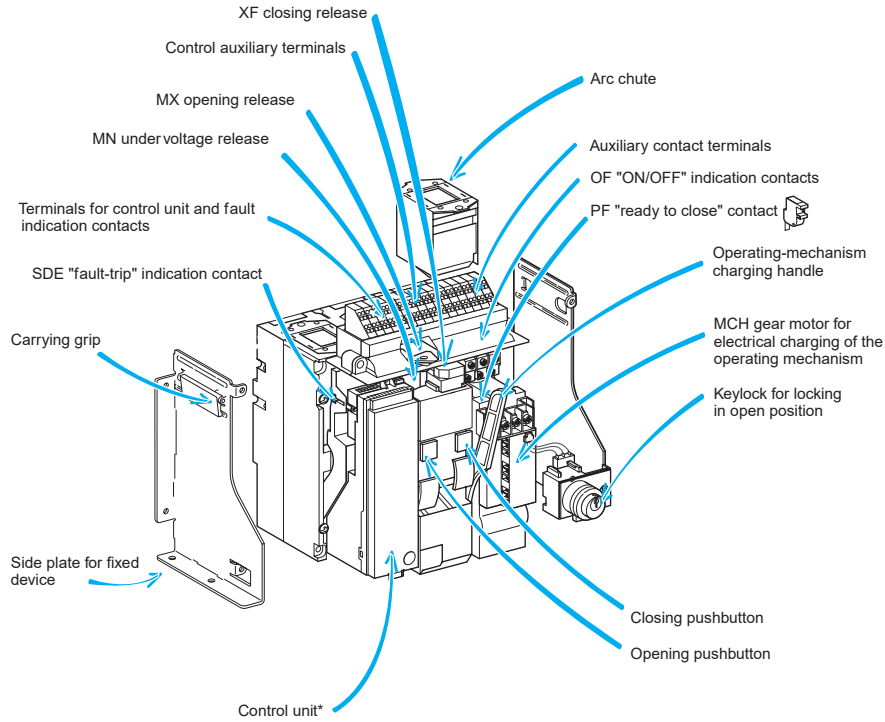

Front

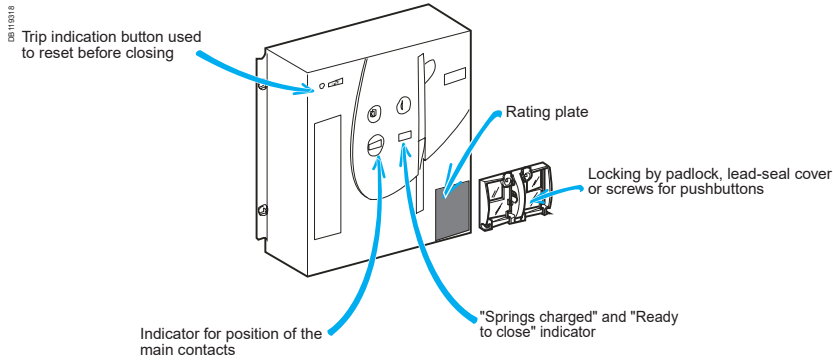

* Switch disconnector is without control unit

*Switch-disconnector is supplied without trip unit.

Circuit breaker / switch-disconnector MVS 08-40 (N/H/T)

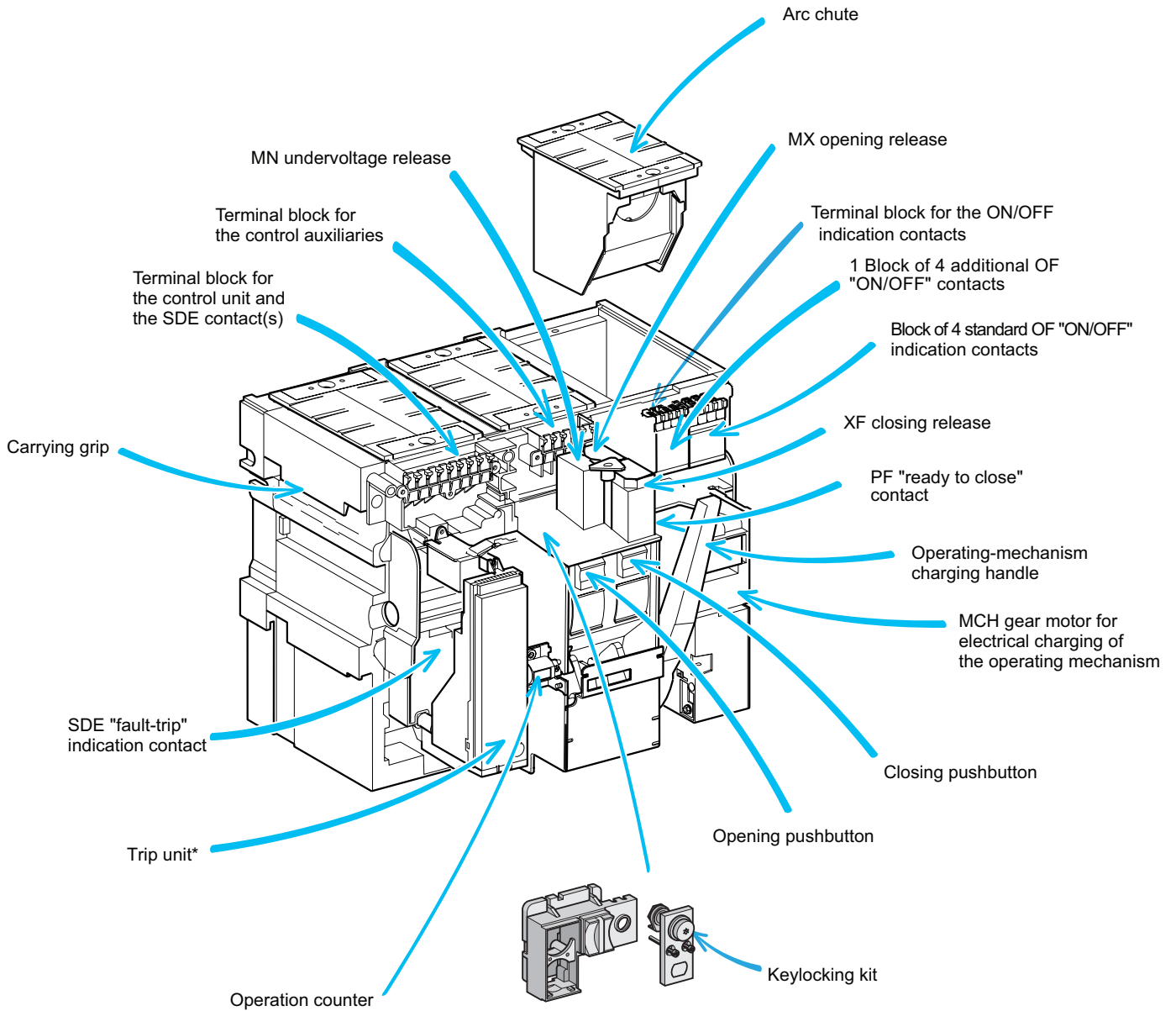

*Switch-disconnector is supplied without trip unit.

Front cover (standard)

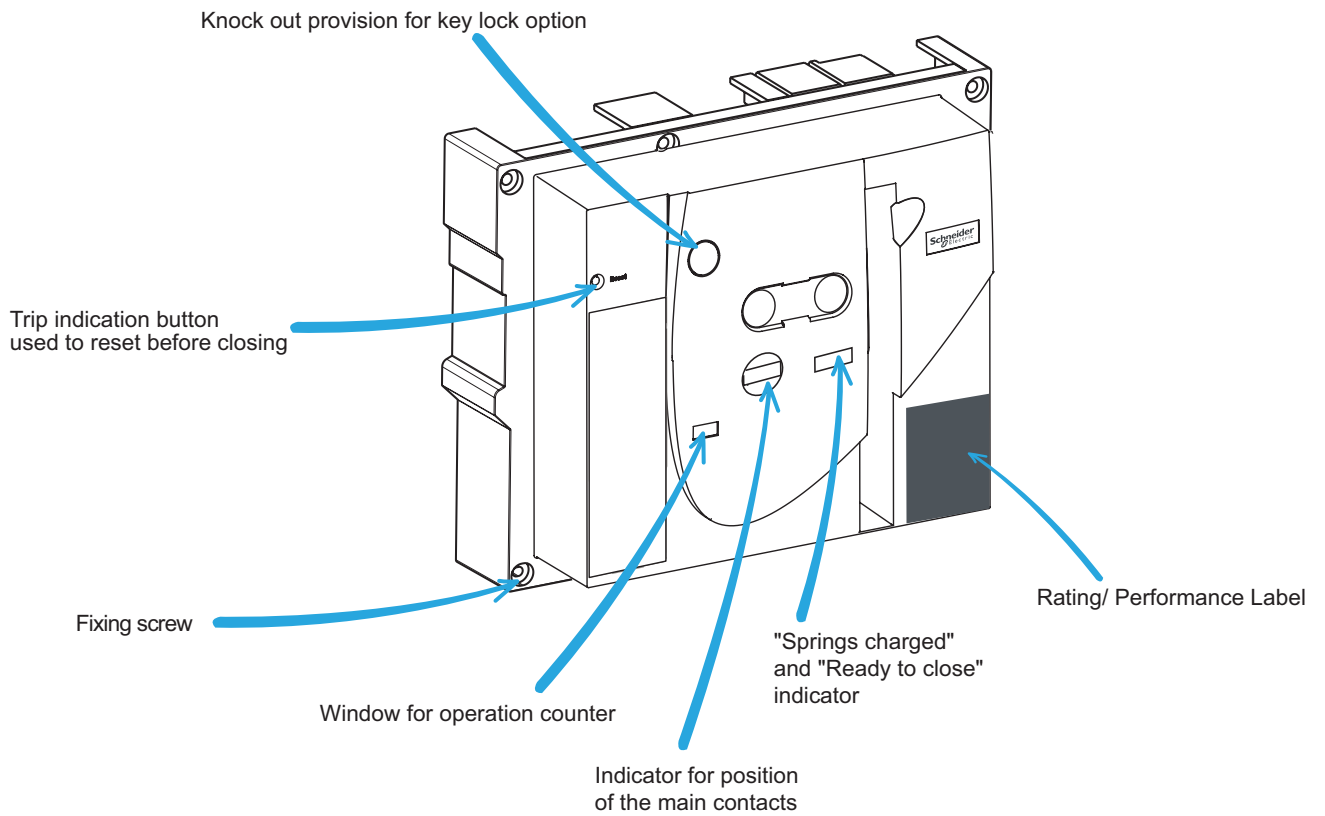

Understanding the controls and indications

EB9775

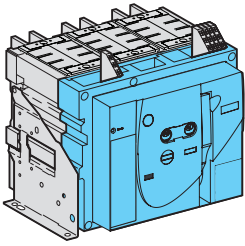

Circuit breaker open and discharged

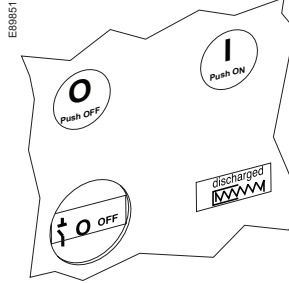

Circuit breaker closed and discharged

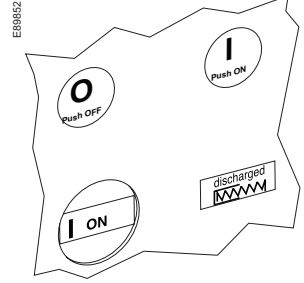

Circuit breaker open, charged and not "ready to close"

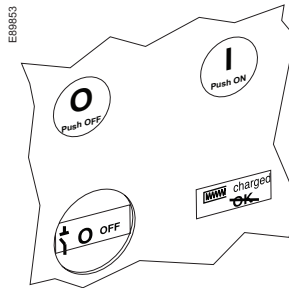

Circuit breaker closed, charged and not "ready to close"

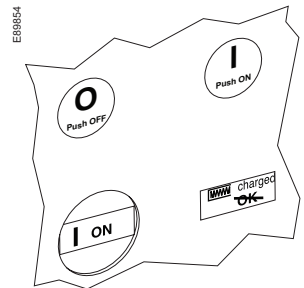

Circuit breaker open, charged and "ready to close"

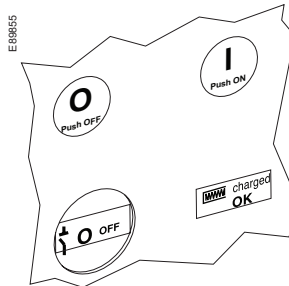

The charge status is indicated as follows.

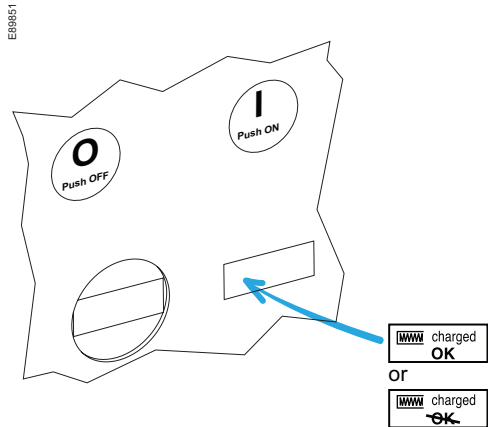

The springs in the circuit breaker operating mechanism must be charged to store the energy required to close the main contacts. The springs may be charged manually using the charging handle or the optional MCH gear motor.

Manual charging:
Pull the handle down seven times until you hear a "clack".

Automatic charging:
If the MCH gear motor is installed, the spring is automatically recharged after each closing.

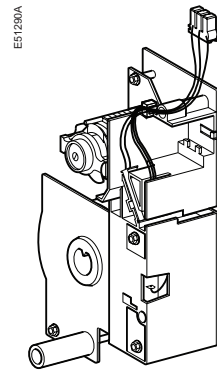
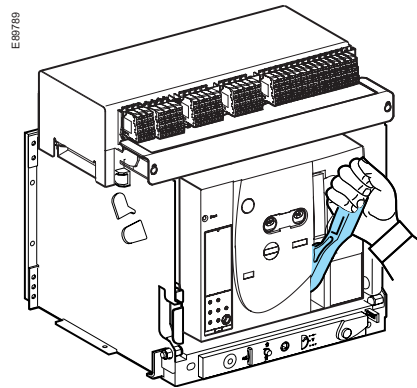

Device "ready to close"



Device not "ready to close"

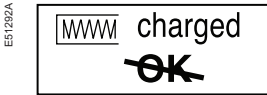

Closing conditions

Closing (i.e. turning the circuit ON) is possible only if the circuit breaker is "ready to close".

The prerequisites are the following:

1. device open (OFF)
2. springs charged
3. no opening order present.

If the circuit breaker is not "ready to close" when the order is given, stop the order and start again when the circuit breaker is "ready to close".

Closing the circuit breakers

Locally (mechanical)

Press the mechanical ON pushbutton.

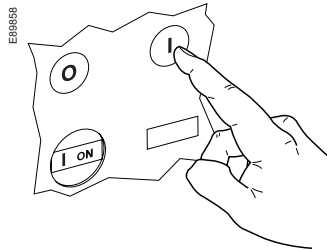
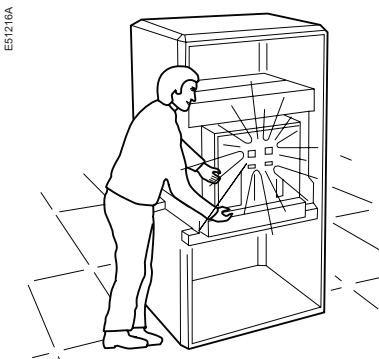

⚠ WARNING

- The device should only be installed and serviced by professionals.
- Avoid installation of XF release at MX position

Failure to follow the instruction of MN-MX-XF can not keep the circuit breaker at OFF position by remote control that resulting equipment damage or risk of life.

Remotely

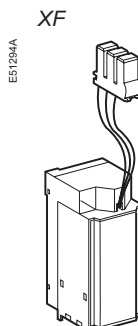

When connected to a remote control panel, the XF closing release (0.85 to 1.1 Un) can be used to close the circuit breaker remotely.

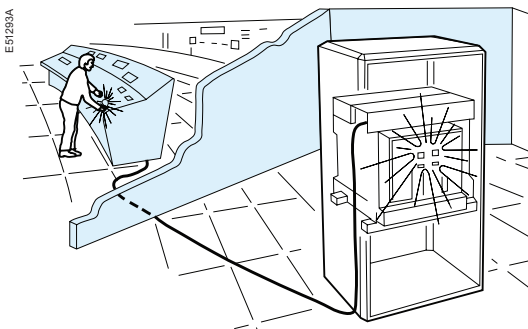

Enabling or disabling the anti-pumping function

The purpose of the mechanical anti-pumping function is to ensure that a circuit breaker receiving simultaneous opening and closing orders does not open and close indefinitely.

If there is a continuous closing order, after opening the circuit breaker remains open until the closing order is discontinued. A new closing order then closes the circuit breaker. This function can be disabled by wiring the closing release in series with the PF "ready to close" contact.

Opening the circuit breaker Resetting after a fault trip

E51216A

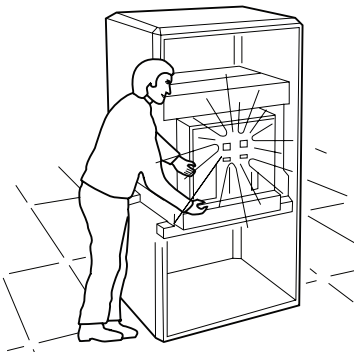

Locally

Press the OFF pushbutton.

E8885B

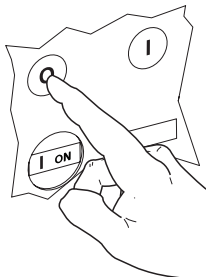

Remotely

Use one of the following solutions:

1. one MX opening releases (0.7 to 1.1 Un)
2. one MN undervoltage release (0.35 to 0.7 Un)
3. one MN undervoltage release (0.35 to 0.7 Un) with a delay unit (R or Rr).

When connected to a remote control panel, these releases can be used to open the circuit breaker remotely.

E51283A

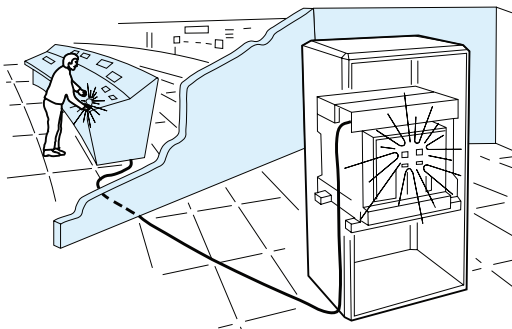

MX, MN

E51284

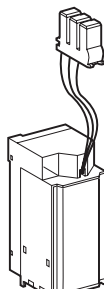

Delay unit

E51286A

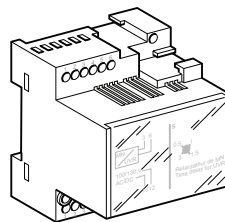

E51216A

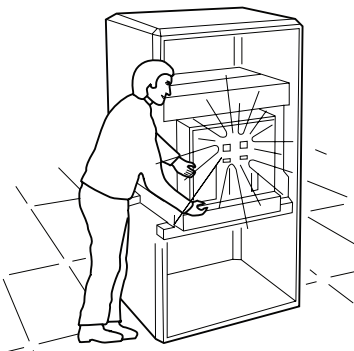

Resetting after a fault trip

The circuit breaker signals a fault by:

1. a mechanical indicator on the front panel
2. one SDE "fault-trip" indication contacts .

Locally

If the circuit breaker is not equipped with the automatic reset option, reset it manually.

E88860

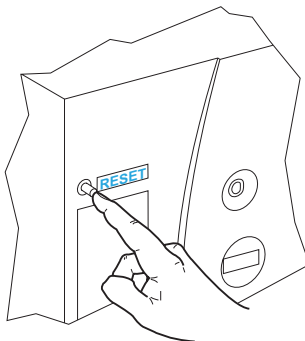

Locking the controls

Disabling circuit-breaker local closing and opening

EB9775

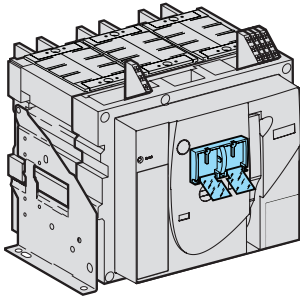

Pushbutton locking using a padlock (shackle diameter 5 to 8 mm), a lead seal or screws.

Padlock

Lead seal

Screws

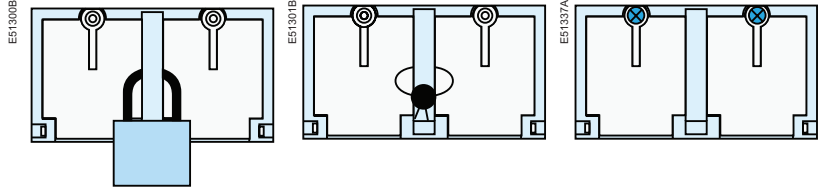

Locking

Close the covers.

Insert the padlock shackle, lead seal or screws.

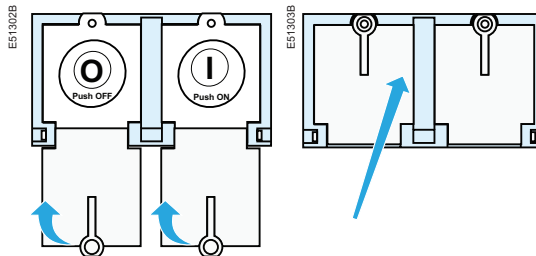

Unlocking

Remove the padlock, lead seal or screws.

Lift the covers and swing them down.

The pushbuttons are no longer locked.

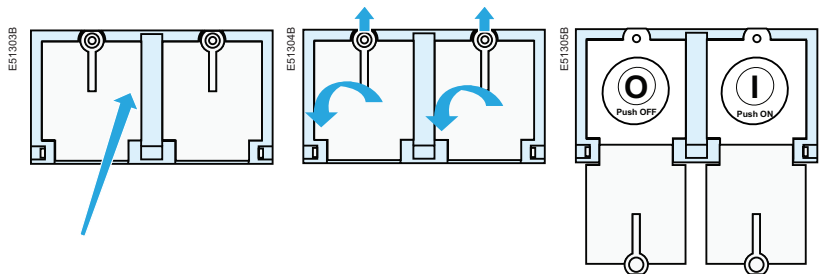

Locking the controls

Disabling local and remote closing

Locking the controls with one keylock

Locking

Open the circuit breaker. Turn the key, anti-clockwise. Remove the key.

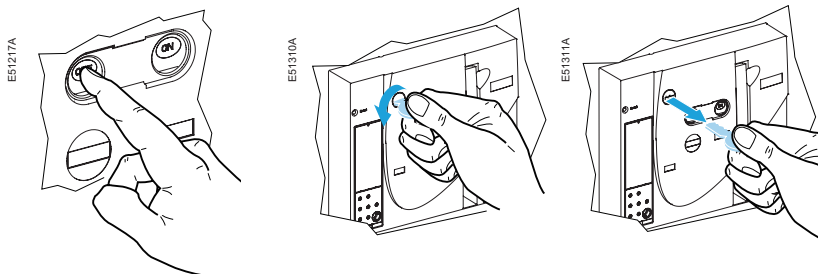

Check

The controls are inoperative.

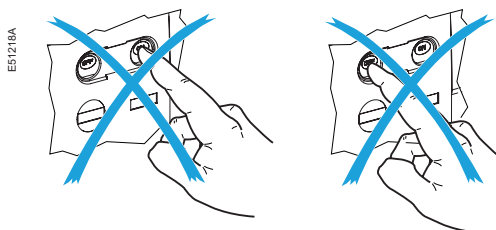

Unlocking

Insert the key. Turn the key, clockwise. The key cannot be removed.

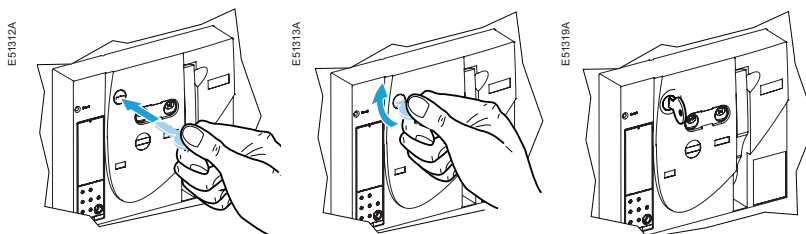

Two types of keylocks are available.

RONIS

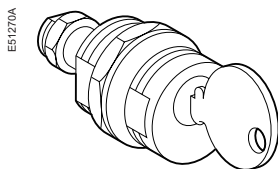

PROFALUX

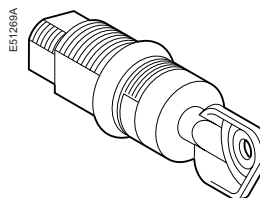

Identifying the circuit breaker positions

MVS 06-16(C)

The indicator on the front signals the position of the circuit breaker in the chassis.

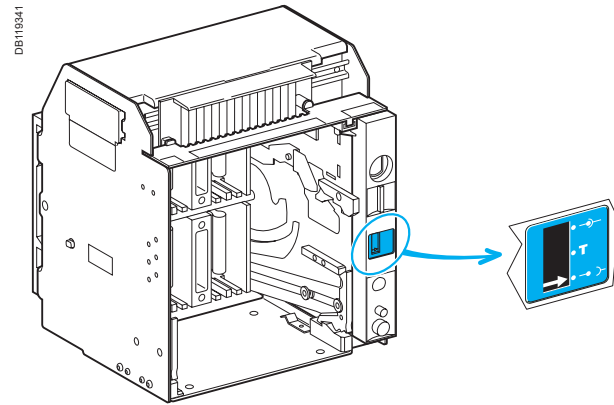

■ "connected" position

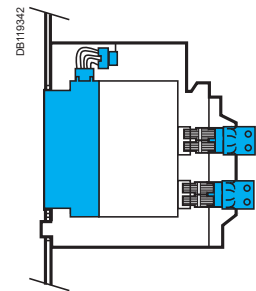
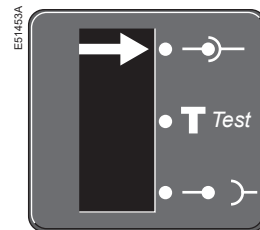

■ "test" position

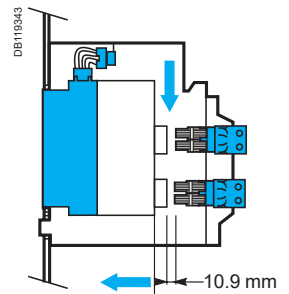
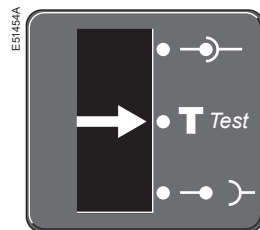

■ "disconnected" position

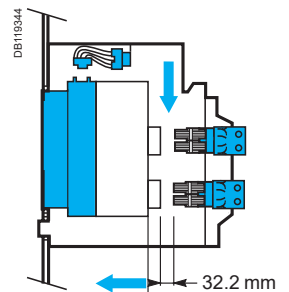
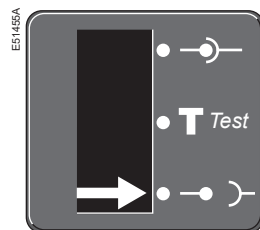

Identifying the circuit breaker positions

MVS 08-40(N/H/T)

The indicator on the front signals the position of the circuit breaker in the chassis.

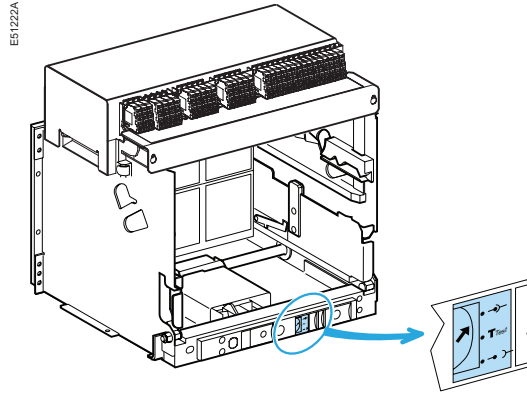

1. "connected" position

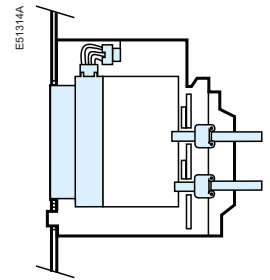
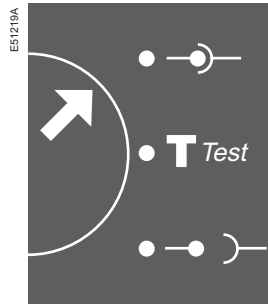

2. "test" position

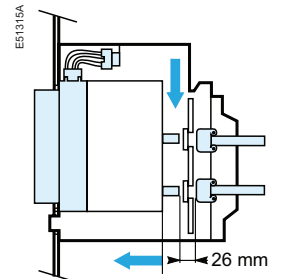
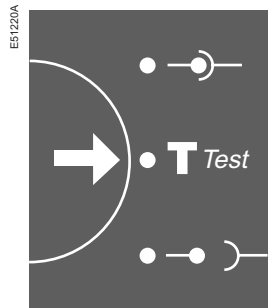

3. "disconnected" position

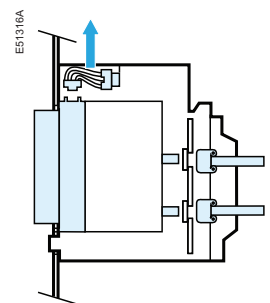
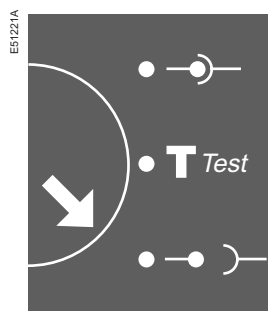

MVS 06-16(C)

These operations require that all chassis-locking functions be disabled (see page 21).

Prerequisites

To connect and disconnect EasyPact, the crank must be used. The locking systems and padlocks all inhibit use of the crank.

Withdrawing the circuit breaker from the "connected" to "test" position, then to "disconnected" position

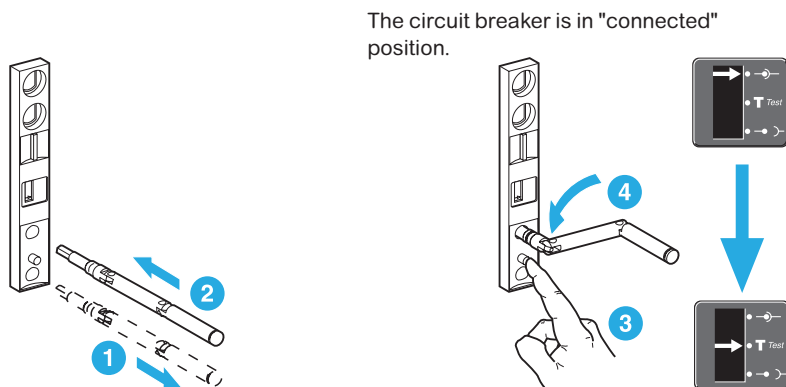

The circuit breaker is in "test" position.

The circuit breaker is in "test" position. Remove the crank or continue to "disconnected" position.

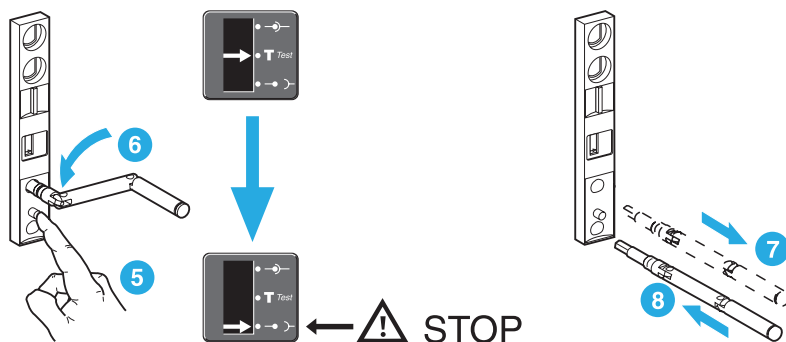

MVS 06-16(C)

For complete information on EasyPact handling and mounting, see the installation manual(s).

Before mounting the circuit breaker, make sure it matches the chassis.

Removing the rails

Press the release tabs and pull the rails out.

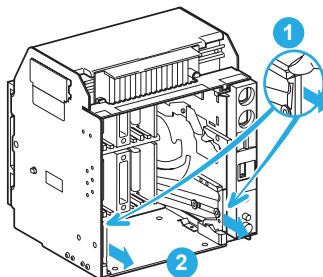

Press the release tabs to push the rails in.

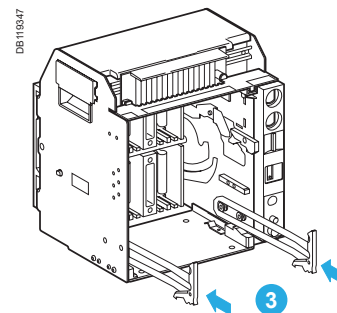

Inserting EasyPact

Position the circuit breaker on the rails. Check that it rests on all four supports.

Open the circuit breaker (in any case, it opens automatically during connection).

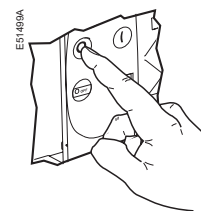
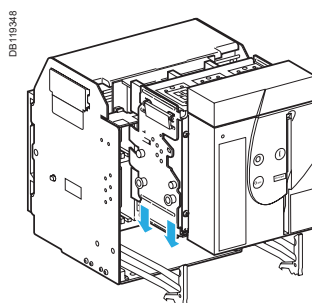

Push the circuit breaker into the chassis, taking care not to push on the control unit.

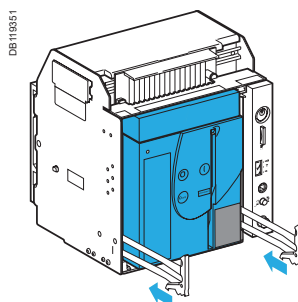
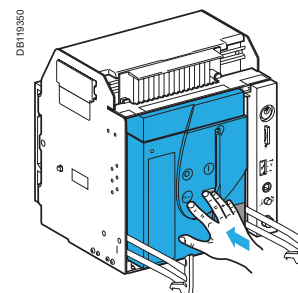
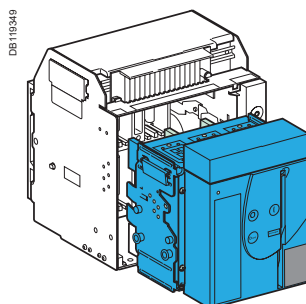

MVS 06-16(C)

Racking the circuit breaker from the "disconnected" to "test" position, then to "connected" position

The device is in "disconnected" position.

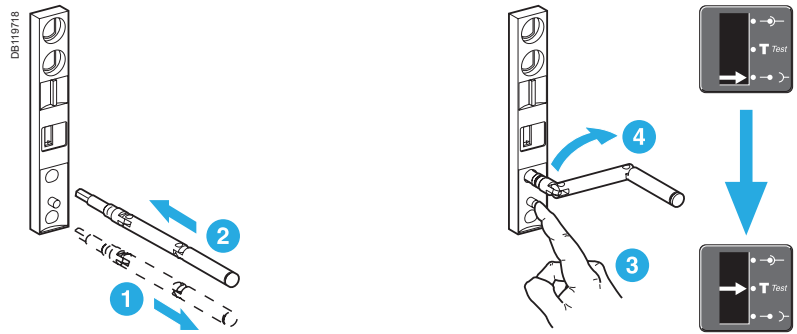

The device is in "test" position.

The device is in "test" position. Remove the crank or continue to "connected" position.

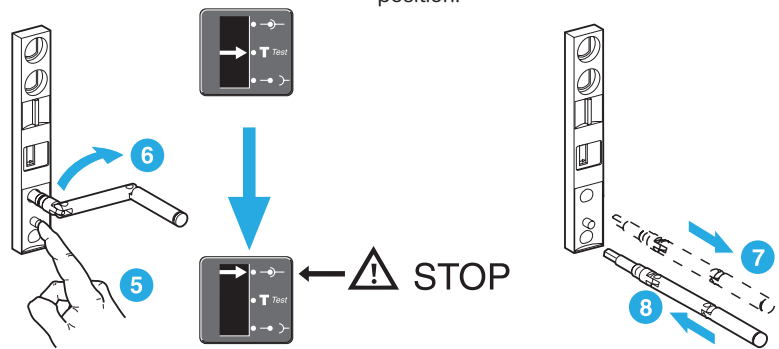

The device is in "connected" position.

MVS 08-40(N/H/T)

These operations require that all chassis-locking functions be disabled.

Prerequisites

To connect and disconnect EasyPact MVS, the crank must be used. The locking systems and padlocks inhibit use of the crank.

Withdrawing the circuit breaker from the "connected" to "test" position, then to "disconnected" position

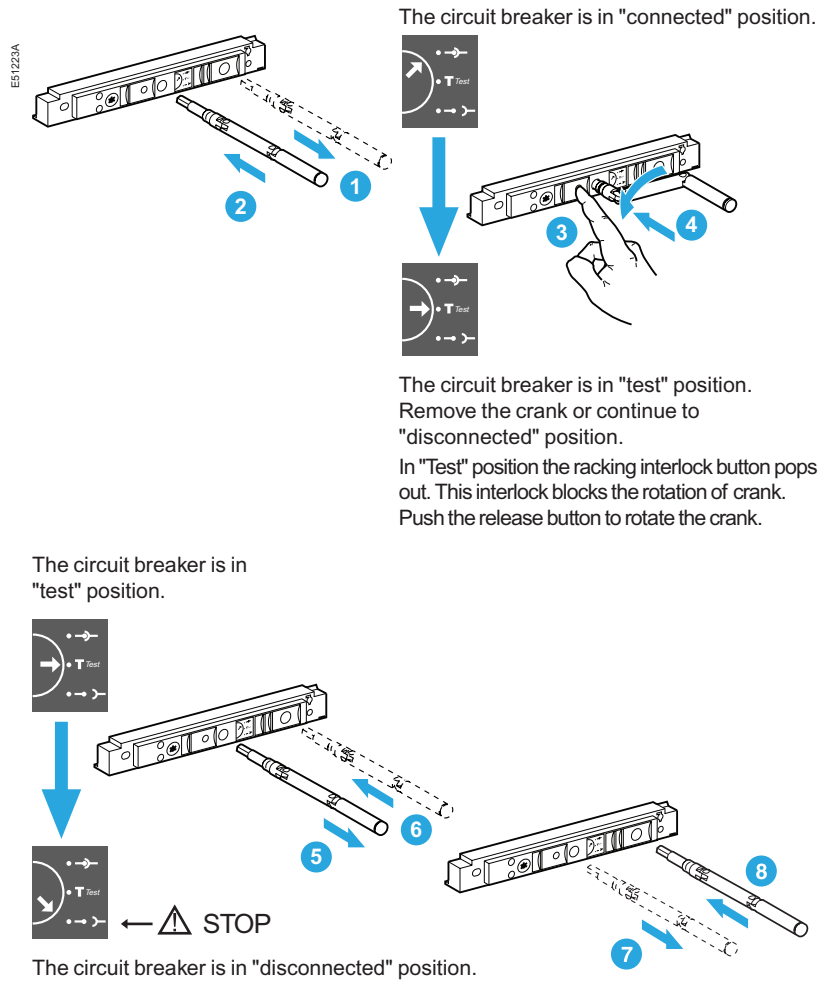

⚠ WARNING

- Avoid rotation of crank anticlockwise when the device is in "disconnected" position.
- Avoid rotation of crank clockwise when the device is in "connected" position.

Failure to follow the instruction can result in equipment damage.

Removing the rails

Press the release tabs and pull the rails out.

To put the rails back in, press the release tabs and push the rails in.

Caution. The right-hand rail cannot be removed if the crank has not been removed or if the circuit breaker is not fully disconnected.

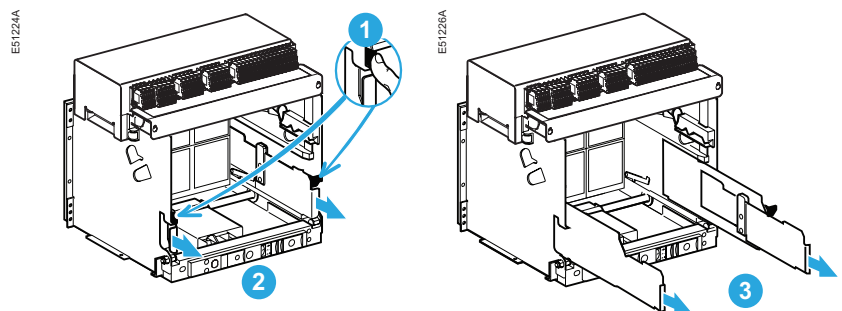

MVS 08-40(N/H/T)

For complete information on EasyPact MVS handling and mounting, see the installation manual(s).

Before mounting the circuit breaker, make sure it matches the chassis.

Inserting EasyPact MVS

Position the circuit breaker on the rails. Check that it rests on all four supports.

Open the circuit breaker (in any case, it opens automatically during connection).

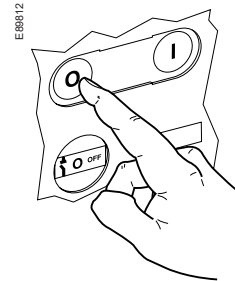
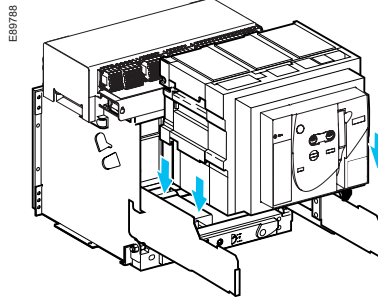

Push the circuit breaker into the chassis, taking care not to push on the ET Trip System.

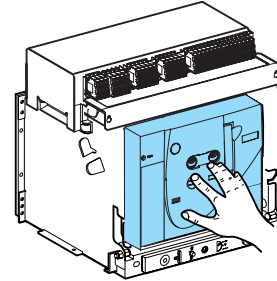
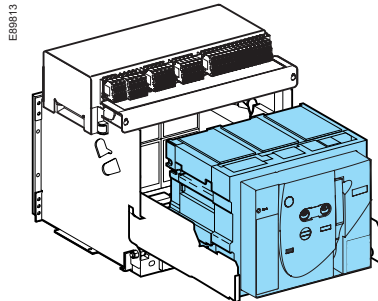

Racking the circuit breaker from the "disconnected" to "test" position, then to "connected" position

The device is in "disconnected" position

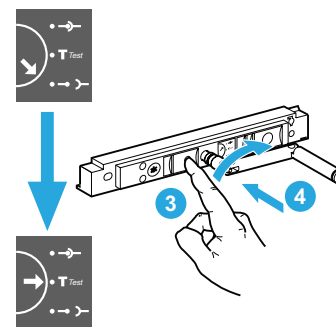
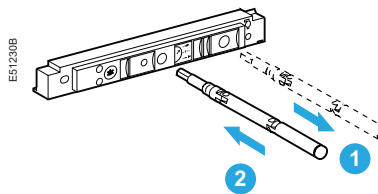

The device is in "test" position. Remove the crank or continue to "connected" position.

In "Test" position the racking interlock button pops out. This interlock blocks the rotation of crank. Push the release button to rotate the crank.

The device is in "test" position.

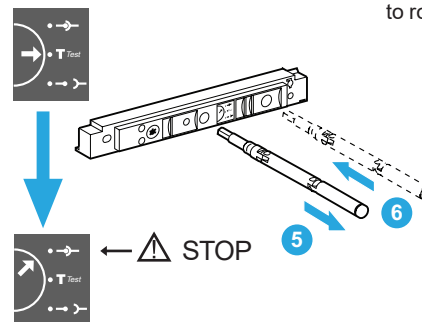

The device is in "connected" position.

⚠ WARNING

- Avoid rotation of crank anticlockwise when the device is in "disconnected" position.
 - Avoid rotation of crank clockwise when the device is in "connected" position.
- Failure to follow the instruction can result in equipment damage.

MVS 06-16(C)

Door interlock

The locking device is installed on the left or right-hand side of the chassis:

1. when the circuit breaker is in "connected" or "test" position, the latch is lowered and the door is locked
2. when the circuit breaker is in "disconnected" position, the latch is raised and the door is unlocked.

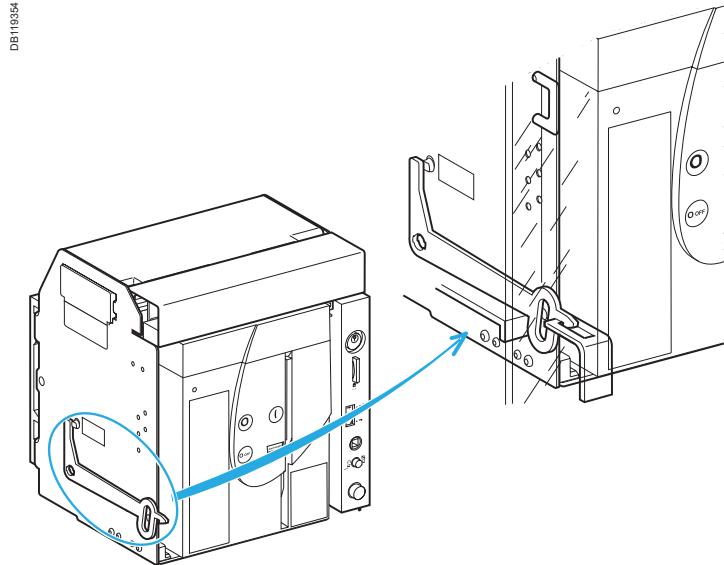

Disabling door opening

Close the door.

Put the EasyPact MVS in "test" or "connected" position.

The door is locked.

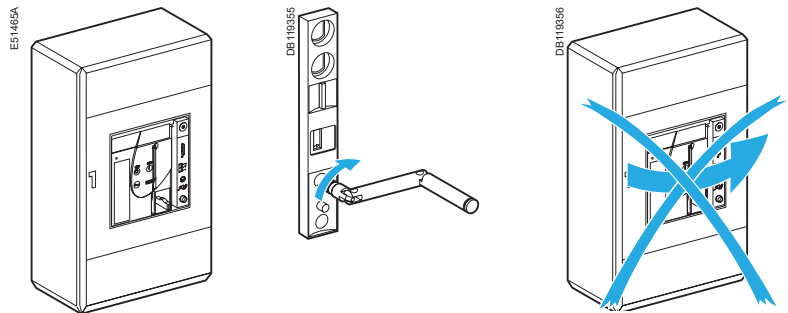

Enabling door opening

Put the EasyPact MVS in "disconnected" position.

The door is unlocked.

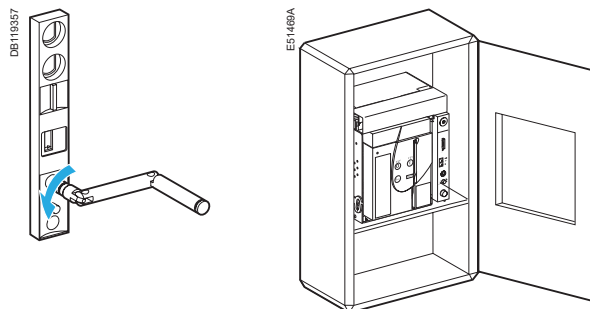

MVS 08-40(N/H/T)

Door interlock

The locking device is installed on the left or right-hand side of the chassis:

1. when the circuit breaker is in "connected" or "test" position, the latch is lowered and the door is locked
2. when the circuit breaker is in "disconnected" position, the latch is raised and the door is unlocked.

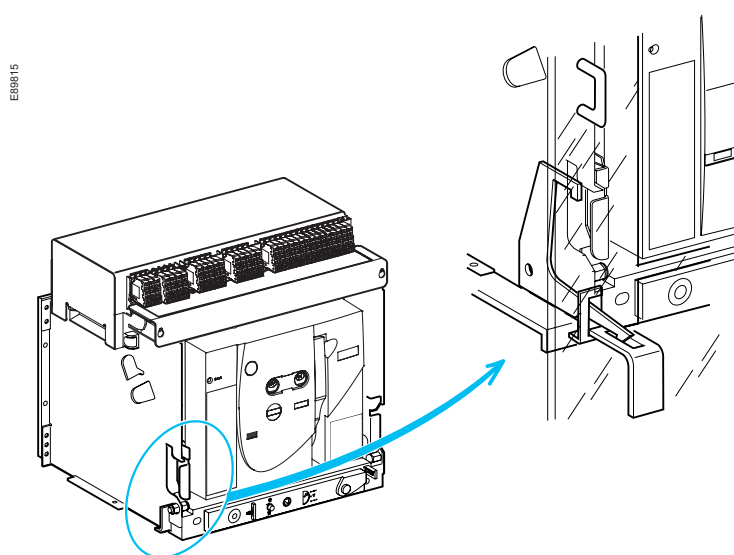

Disabling door opening

Close the door.

Put the EasyPact MVS in
"test" or "connected" position.

The door is locked.

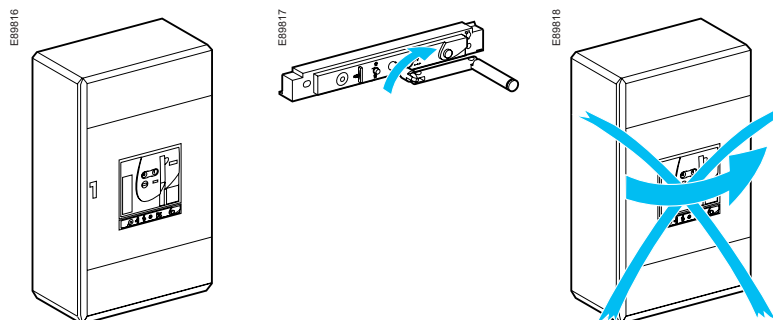

Enabling door opening

Put the EasyPact MVS in
"disconnected" position.

The door is unlocked.

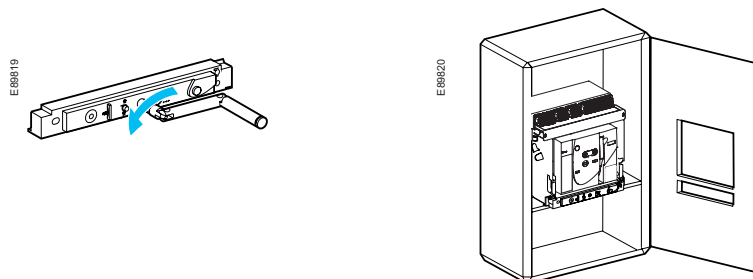

MVS 06-16 (C)

Padlocks and keylocks may be used together. Padlocks are not supplied.

If specified when ordering the chassis, this locking function may be adapted to operate in all positions ("connected", "test" and "disconnected"), instead of in "disconnected" position alone.

Locking the circuit breaker in position Using padlocks

Combination of locking systems

To disable connection of the circuit breaker in "disconnected" position in the chassis, use as needed:

1. one to three padlocks
2. one keylock
3. a combination of the two locking systems.

Disabling connection when the circuit breaker is in "disconnected" position, using one to three padlock (maximum shackle diameter 5 to 8 mm)

Locking

Circuit breaker in "disconnected" position.

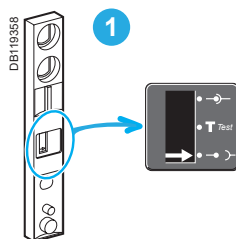

Pull out the tab.

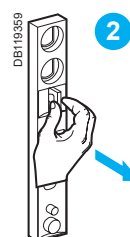

Insert the shackle(max.diameter 5 to 8 mm) of the padlock(s).

The crank cannot be inserted.

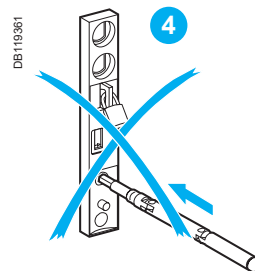
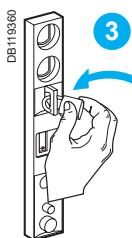

Unlocking.

Remove the padlock(s).

Release the tab.

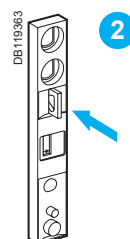
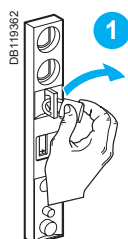

The crank can be inserted.

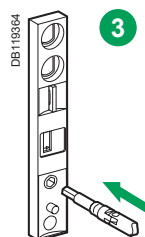

Locking the circuit breaker in disconnected position

MVS 06-16 (C)

Padlocks and keylocks may be used together.
Padlocks are not supplied.

Disabling connection when the circuit breaker is in "disconnected" position, using one keylock

Locking

Circuit breaker in "disconnected" position.

Turn the key(s).

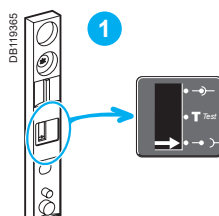

Remove the key(s).

The crank cannot be inserted.

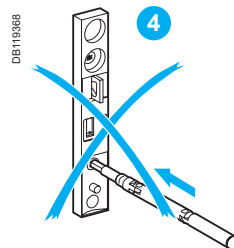
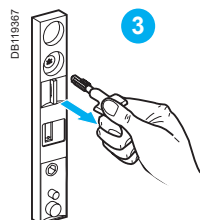

Unlocking

Insert the key(s).

Turn the key(s).

The crank can be inserted.

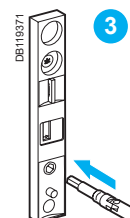
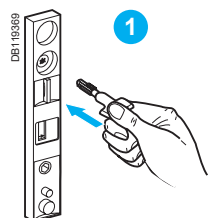

Two type of keylocks are available

RONIS

PROFALUX

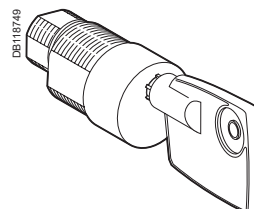
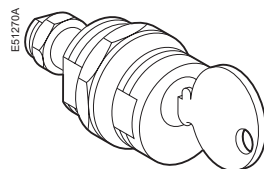

Locking the circuit breaker in disconnected position

MVS 08-40(N/H/T)

Padlocks and keylocks may be used together.

Combination of locking systems

To disable local or remote opening or closing of the circuit breaker, use as needed:

1. one to three padlocks (not supplied with circuit breaker)
2. one keylock (not supplied with circuit breaker)
3. a combination of the two locking systems.

Disabling connection when the circuit breaker is in "disconnected" position, using one padlock (maximum shackle diameter 5 to 8 mm)

Locking

Circuit breaker in "disconnected" position.

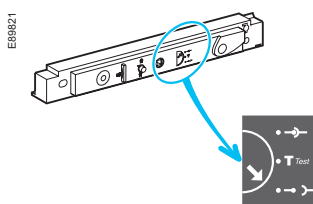

Pull out the tab.

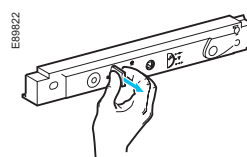

Insert the shackle(max. diameter 5 to 8 mm) of the padlock.

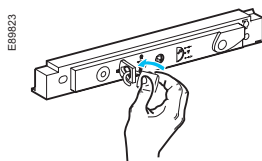

The crank cannot be inserted.

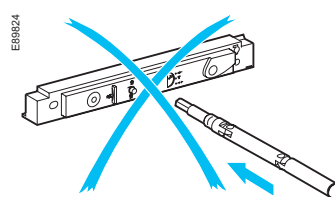

Unlocking.

Remove the padlock.

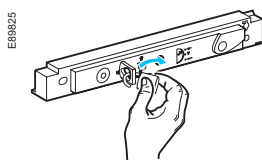

Release the tab.

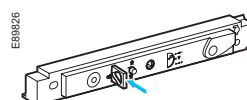

The crank can be inserted.

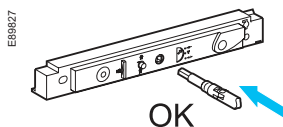

Locking the circuit breaker in disconnected position

MVS 08-40(N/H/T)

Padlocks and keylocks may be used together.

Disabling connection when the circuit breaker is in "disconnected" position, using one keylock

Locking
Circuit breaker in "disconnected" position.

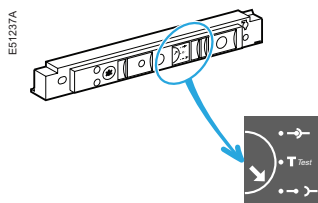

Turn the key.

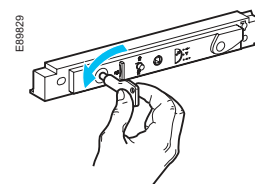

Remove the key.

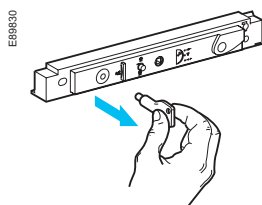

The crank cannot be inserted.

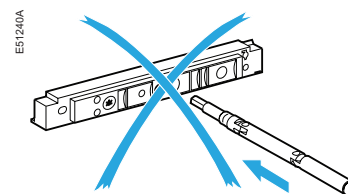

Unlocking
Insert the key.

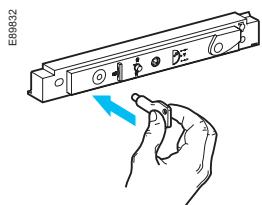

Turn the key.

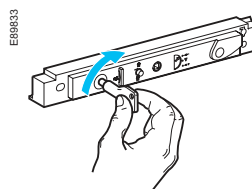

The crank can be inserted.

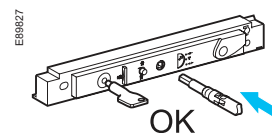

Two type of keylocks are available
PROFALUX

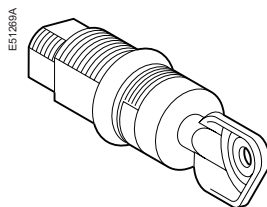

RONIS

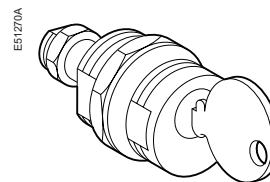

Locking the circuit breaker in all positions

For this operation, the circuit breaker must be removed from the chassis.

Disabling use of the crank in all positions

It is possible to modify the padlock and keylock locking function. Instead of locking only in "disconnected" position, it is possible to lock the circuit breaker in all positions.

Set the circuit breaker to "disconnected" position. Remove the circuit breaker from the chassis.

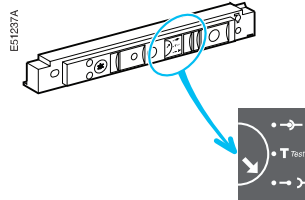

Insert the crank.

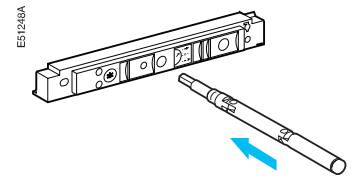

Turn the catch to the right. The circuit breaker can now be locked in all positions.

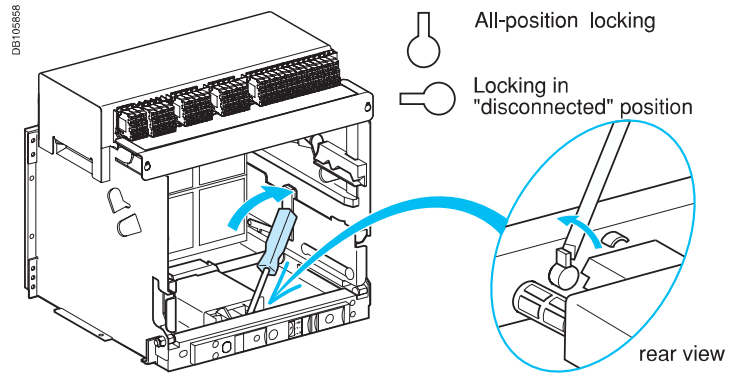

MVS 06-16 (C)

Padlocks are not supplied

Four locking possibilities

Top and bottom shutters not locked.

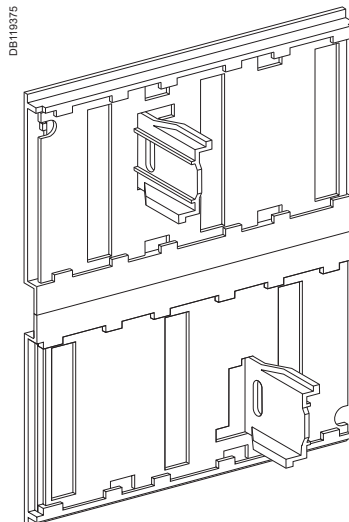

Top shutter not locked,
Bottom shutter locked.

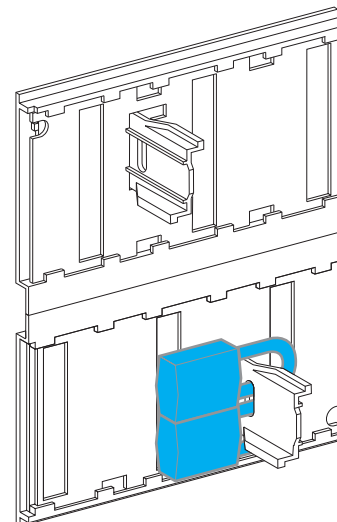

Top shutter locked,
Bottom shutter not locked.

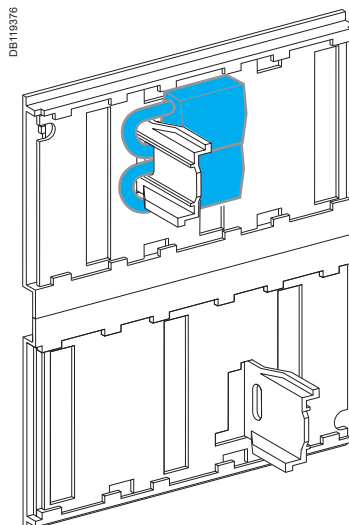

Top and bottom shutters locked.

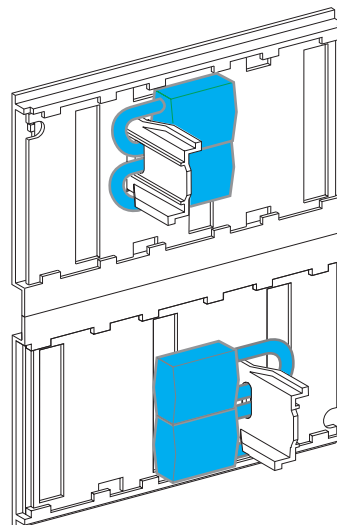

MVS 08-40(N/H/T)

Circuit breaker is not supplied with shutter locking blocks as standard. It has to be ordered separately if required. Part number: 48591.

Using the shutter locking blocks

Remove the block(s) from their storage position.

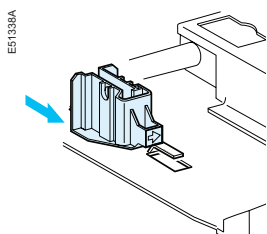

Position the block(s) on the guide(s).

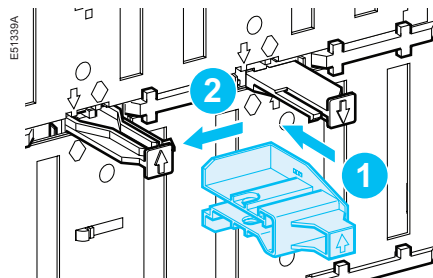

Lock the block(s) using a padlock.

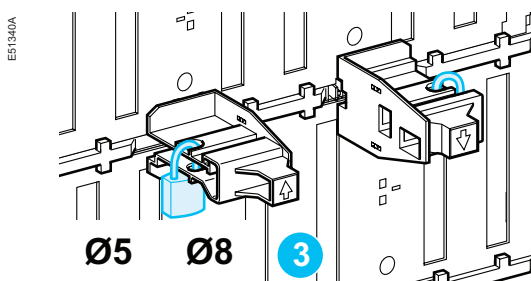

Four locking possibilities

Top and bottom shutters not locked.

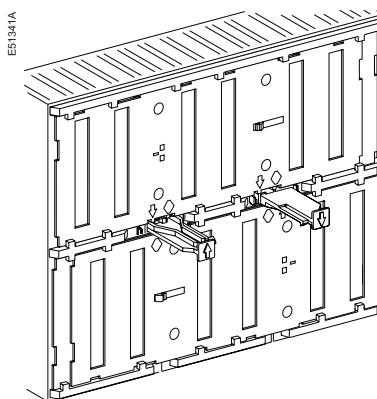

Top shutter locked,
Bottom shutter not locked.

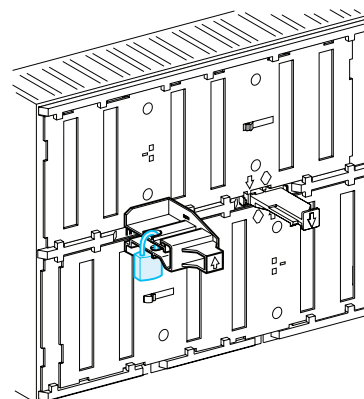

Top shutter not locked,
Bottom shutter locked.

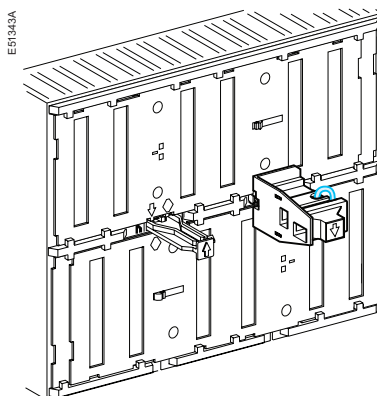

Top and bottom shutters locked.

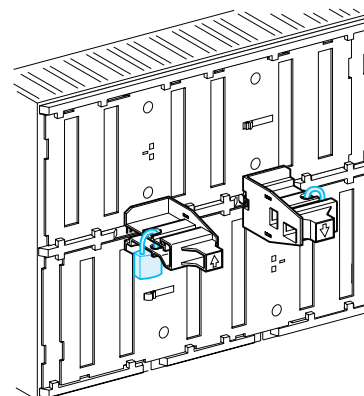

EasyPact MVS air circuit breakers are equipped with ET/ETA/ETV Trip System.
ET range of Trip Systems are designed to protect power circuits and connected loads.

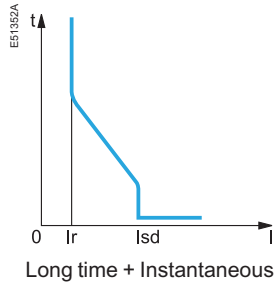

ET/ETA/ETV 2I Trip System: basic protection



ET/ETA/ETV 5S Trip System: selective protection

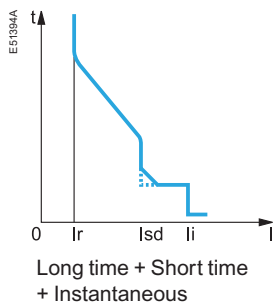
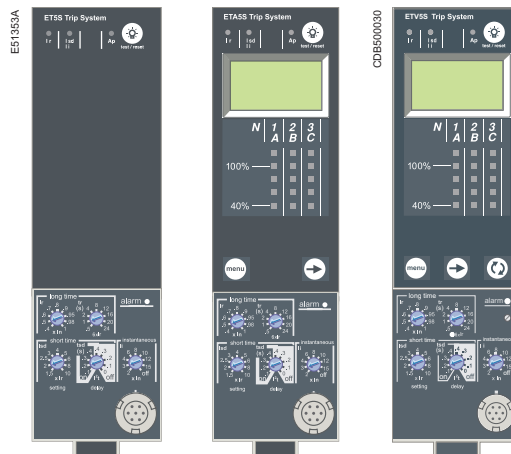
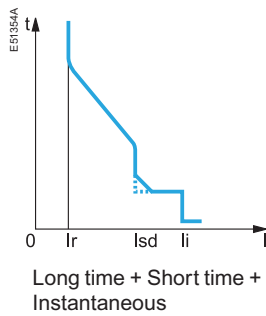

ET/ETA/ETV 6G Trip System: selective + ground-fault protection

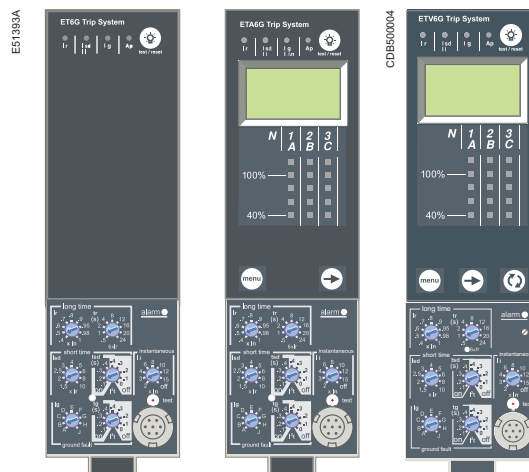
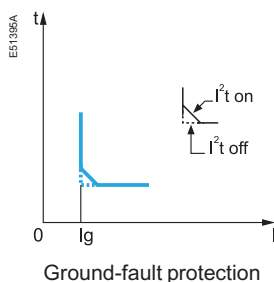

- 1 top fastener
- 2 bottom fastener
- 3 protective cover
- 4 cover opening point
- 5 lead-seal fixture for protective cover
- 6 long-time rating plug
- 7 screw for long-time rating plug
- 8 connection with circuit breaker
- 9 Fault trip indications LEDs
- 10 terminal block for external connections
- 11 housing for battery
- 12 digital display
- 13 three-phase bargraph and ammeter

Adjustment dials

- 14 long-time current setting I_r
- 15 long-time tripping delay t_r
- 16 short-time pickup I_{sd}
- 17 short-time tripping delay t_{sd}
- 18 instantaneous pick-up I_{sd} (only in ET/ETA/ETV 2I)
- 19 instantaneous pick-up I_i
- 20 ground-fault pick-up I_g
- 21 ground-fault tripping delay t_g

Test

- 22 test button for ground-fault and earth-leakage protection
- 23 test connector

Indications

- 24 LED indicating long-time tripping
- 25 LED indicating short-time tripping
- 26 LED indicating ground-fault
- 27 LED indicating auto-protection tripping
- 28 LED indicating an overload alarm

Navigation

- 29 navigation button to change menus
- 30 navigation button to view menu contents
- 31 button for fault-trip reset and battery test
- 32 "Quick View" navigation button (ETV only)

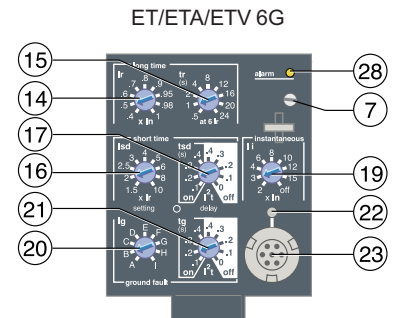
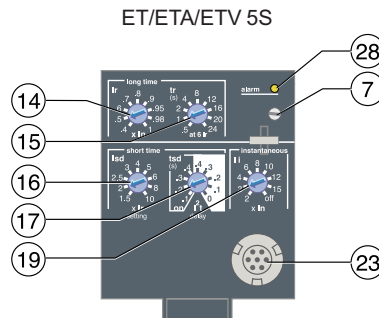
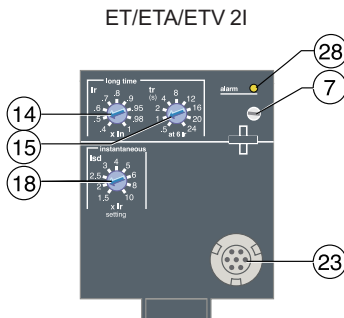
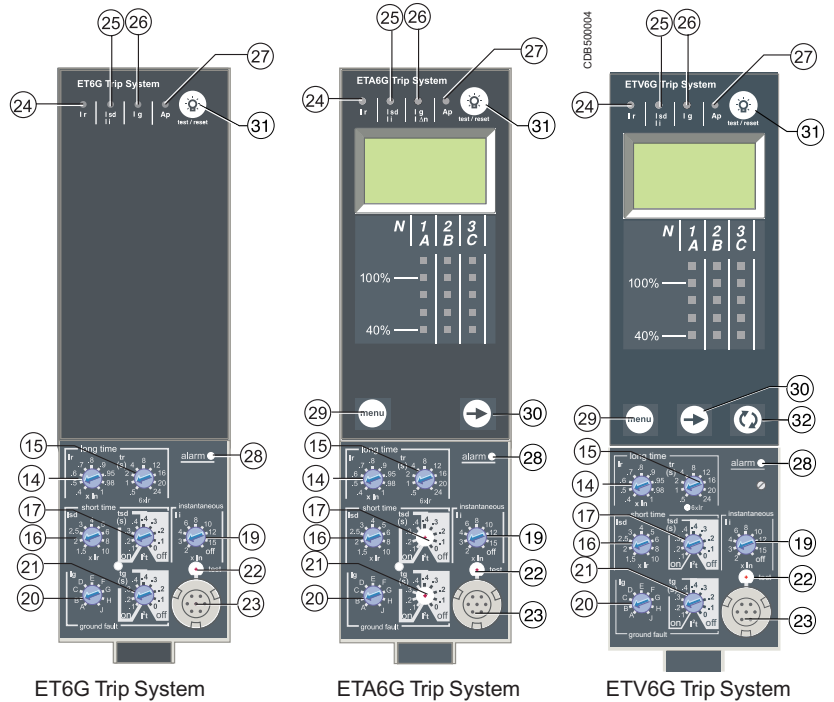
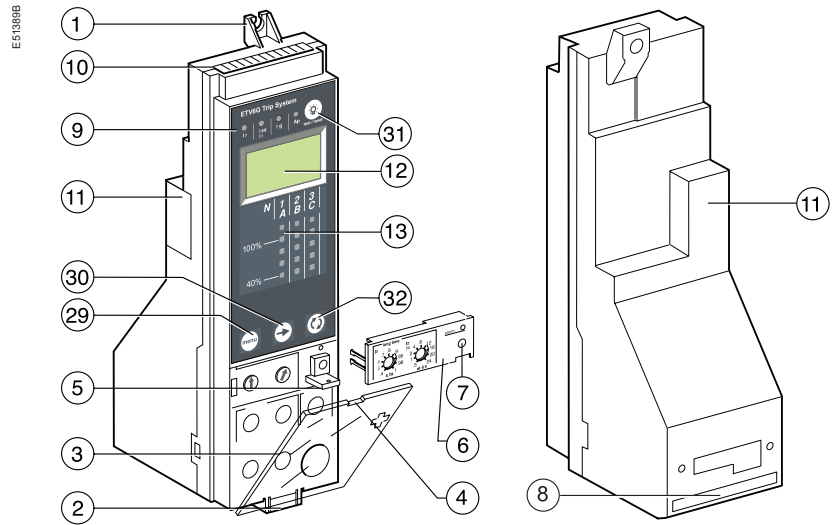

Protection settings

Depending on the type of installation, it is possible to set the tripping curve of your Trip System using the parameters presented below.

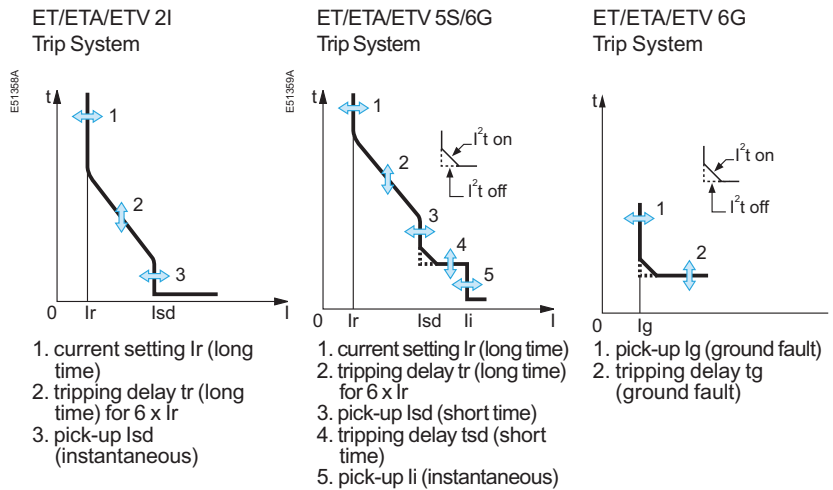

Long-time protection

The long-time protection function protects cables (phases and neutral) against overloads. This function is based on true rms measurements.

Thermal memory

The thermal memory continuously accounts for the amount of heat in the cables, both before and after tripping, whatever the value of the current (presence of an overload or not). The thermal memory optimises the long-time protection function of the circuit breaker by taking into account the temperature rise in the cables. The thermal memory assumes a cable cooling time of approximately 20 minutes.

Long-time current setting I_r and standard tripping delay t_r

ET/ETA/ETV Trip System 2I, 5S and 6G											
current setting	$I_r = I_n (*) \times \dots$	0.4	0.5	0.6	0.7	0.8	0.9	0.95	0.98	1	
tripping between	1.05 and 1.20 I_r										
time setting	Accuracy	0,5	1	2	4	8	12	16	20	24	
time delay (s)	t_r at $1.5 \times I_r$	0 to -30%	12.5	25	50	100	200	300	400	500	600
	t_r at $6 \times I_r$	0 to -20%	0.7 (1)	1	2	4	8	12	16	20	24
	t_r at $7.2 \times I_r$	0 to -20%	0.7 (2)	0.69	1.38	2.7	5.5	8.3	11	13.8	16.6

(*) I_n : circuit breaker rating

(1) 0 to -40%

(2) 0 to -60%

Overload LED

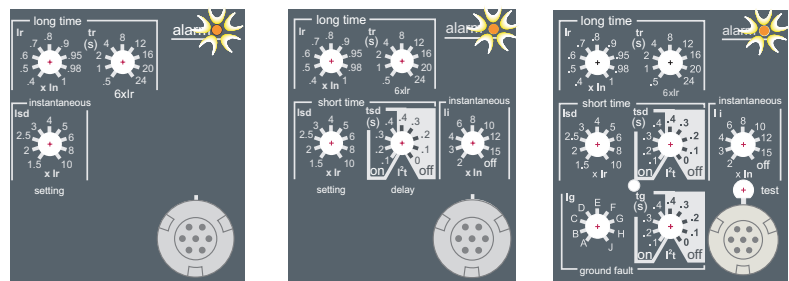

This LED signals that the long-time current setting I_r has been overrun.

Zone selective interlocking (ZSI):

The short-time and ground-fault protection functions enable time discrimination by delaying the upstream devices to provide the downstream devices the time required to clear the fault. Zone selective interlocking can be used to obtain total discrimination between circuit breakers using external wiring.

For the characteristics and external wiring of the zone selective interlocking function, see the technical appendix on "Zone selective interlocking". See page no.54.

The portable test kit can be used to test the wiring between circuit breakers for the zone selective interlocking function.

Short-time protection

1. the short-time protection function protects the distribution system against independent short-circuits.
2. the short-time tripping delay can be used to ensure discrimination with a downstream circuit breaker.
3. the I²t ON and I²t OFF options enhance discrimination with downstream protection devices.
4. use of I²t curves with short-time protection:
 - a. I²t OFF selected: the protection function implements a constant time curve
 - b. I²t ON selected: the protection function implements an I²t inverse-time curve up to 10 Ir. Above 10 Ir, the time curve is constant.

Short-time pick-up Isd and tripping delay tsd

ET/ETA/ETV Trip System 5S and 6G										
pick-up	Isd = Ir x ... accuracy ± 10%	1.5	2	2.5	3	4	5	6	8	10
time delay (ms) at 10 Ir	setting	I ² t Off	0	0.1	0.2	0.3	0.4			
		I ² t On		0.1	0.2	0.3	0.4			
I ² t On or	tsd (max resettable time)	20	80	140	230	350				
I ² t Off	tsd (max break time)	80	140	200	320	500				

Instantaneous protection

the instantaneous-protection function protects the distribution system against solid short-circuits. Contrary to the short-time protection function, the tripping delay for instantaneous protection is not adjustable.

The tripping order is sent to the circuit breaker as soon as current exceeds the set value, with a fixed time delay of 20 milliseconds.

Instantaneous pick-up Ili

ET/ETA/ETV Trip System 2I										
pick-up	Isd = Ir x ... accuracy ± 10 %	1.5	2	2.5	3	4	5	6	8	10
time delay (ms)	tsd (max resettable time)	20								
	tsd (max break time)	80								

Instantaneous pick-up Ili

ET/ETA/ETV Trip System 5S and 6G										
pick-up	Ii = In (*) x ... accuracy ± 10 %	2	3	4	6	8	10	12	15	OFF
time delay (ms)	tsd (max resettable time)	20								
	tsd (max break time)	50								

Refer to page no.33 on selecting the type of neutral protection.

Protection of the fourth pole on four-pole circuit breakers

Protection of the neutral conductor depends on the distribution system.

There are three possibilities.

1. Neutral unprotected
2. Neutral protection at 0.5 In
3. Neutral protection at In

Neutral protection for three-pole devices

Neutral protection is not available on three-pole devices.

Ground-fault protection on ET6G Trip System

An ground fault in the protection conductors can provoke local temperature rise at the site of the fault or in the conductors.

The purpose of the ground-fault protection function is to eliminate this type of fault.

Type	Description
Residual	<ol style="list-style-type: none"> 1. the function determines the zero-phase sequence current, i.e. the vectorial sum of the phase and neutral currents 2. it detects faults downstream of the circuit breaker.

1. ground-fault and neutral protection are independent and can therefore be combined.
2. ground-fault protection in 3P+N system is activated by installing a external sensor(CT) in the neutral conductor and connecting to ET Trip System.

Ground-fault pick-up Ig and tripping delay tg

The pick-up and tripping-delay values can be set independently.

ET/ETA/ETV Trip System 6G										
pick-up	Ig = In (*) x ... accuracy ± 10 %	A	B	C	D	E	F	G	H	I
	In ≤ 1200 A	0.2	0.3	0.4	0.5	0.6	0.7	0.8	0.9	1
	In > 1200 A	500 A	640 A	720 A	800 A	880 A	960 A	1040 A	1120 A	1200 A
time delay (ms) at 10 In (*)	settings I ² t OFF	0	0.1	0.2	0.3	0.4				
	I ² t ON		0.1	0.2	0.3	0.4				
I ² t ON or	tg (max resettable time)	20	80	140	230	350				
I ² t OFF	tg (max break time)	80	140	200	320	500				

* In: circuit-breaker rating

The auto-protection function (excessive temperature or short-circuit higher than circuit-breaker capacity) opens the circuit breaker and turns on the Ap LED.

Caution.
If the circuit breaker remains closed and the Ap LED remains on, contact the Schneider after-sales support department.

Caution.
The battery maintains the fault indications.
If there are no indications, check the battery.

Fault indications

Signals tripping due to an overrun of the long-time current setting I_r .

Signals tripping due to an overrun of the short-time pick-up I_{sd} or the instantaneous pick-up I_d / I_i .

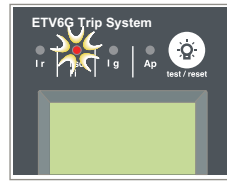
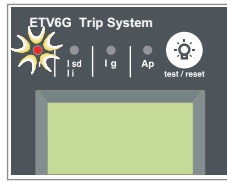

Signals tripping due to an overrun of the ground fault pick-up I_g

Signals tripping due to the auto-protection, Ap function of the Trip System

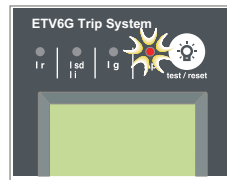
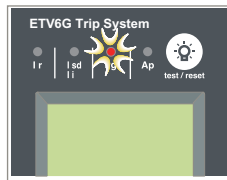

See the user manual of Hand-held test kit. (HHTK)

Testing ET/ETA/ETV Trip System Using the Hand Held Test Kit (HHTK)

To test the control unit, connect the hand held test kit via the test connector.

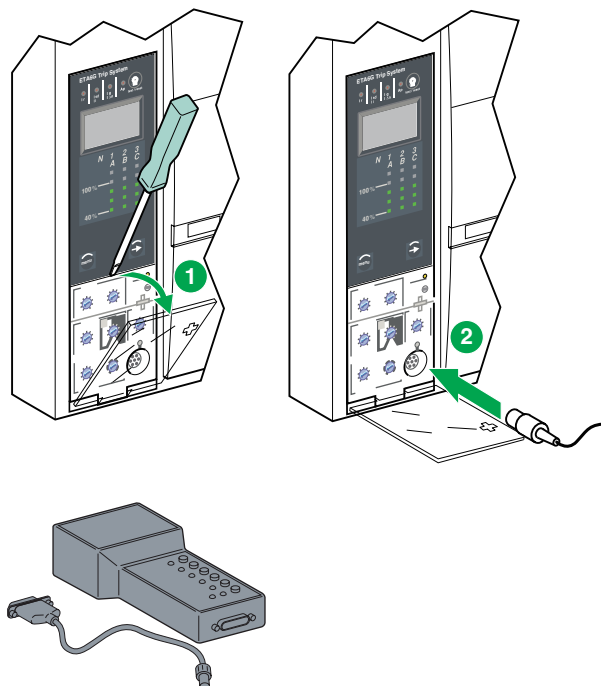

Measurement and display possibilities

- ETA measures instantaneous currents and stores the maximum values in maximeters.
- In addition to the values measured by ETA, ETV trip unit measures both current and voltage.

ETA and ETV measurements can be displayed on:

- the digital screen of trip unit
- a PC via the screen of the control unit

In addition, a bargraph on the front of the control unit continuously displays the currents measured on phases 1, 2 and 3 as a percentage of the long-time current setting I_r .

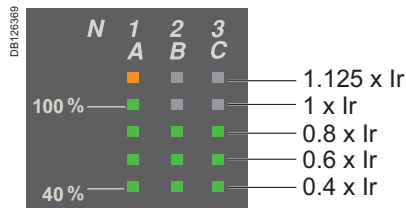

The following table indicates ETA and ETV measurement and display possibilities.

Measurements	ETA	ETV	Displayed on...	
			Trip system	COM
Instantaneous currents $I_1, I_2, I_3, I_N, I_g (I_{\Delta N})$ ⁽¹⁾	■	■	■	■
Current maximeters $I_1 \max, I_2 \max, I_3 \max, I_N \max, I_g \max, (I_{\Delta N} \max)$ ⁽¹⁾	■	■	■	■
Demand current $\overline{I_1}, \overline{I_2}, \overline{I_3}, \overline{I_N}$ ⁽¹⁾		■	■	■
Demand current maximeters (peak demand) $\overline{I_1} \max, \overline{I_2} \max, \overline{I_3} \max, \overline{I_N} \max$ ⁽¹⁾		■		■
Phase-to-phase voltages V_{12}, V_{23}, V_{31} (3-wire and 4-wire systems)		■	■	■
Phase-to-neutral voltages V_{1N}, V_{2N}, V_{3N} (4-wire systems) ⁽²⁾		■	■	■
Average voltage V_{avg}		■		■
Voltage unbalance V_{unbal}		■		■
Instantaneous powers P, Q, S		■	■	■
Power maximeters $P_{max}, Q_{max}, S_{max}$		■		■
Demand active power \overline{P}		■	■	■
Demand apparent power \overline{S}		■		■
Demand power maximeter (peak demand) P_{max}		■		■
Instantaneous power factor PF		■	■	■
Active energy E_p		■	■	■
Reactive and apparent energy E_q, E_s		■		■

⁽¹⁾ The display of the Neutral current (I_N) is available with ETV when the parameter "type of network" has been set to 4 Wire 4CT (44). See page 50.

⁽²⁾ Important: for 3-pole circuit breakers used on 4-wire systems (3ph + N), terminal VN on the Trip system control unit must always be connected to the neutral. If this is not done, the phase-to-neutral voltage measurements can be erroneous.

Note: If no information is displayed on the screen, see: "Digital display" in the technical appendix.

Measurement definitions

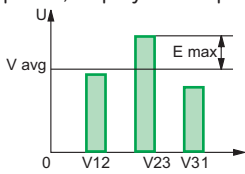
Measurements	Definition
Instantaneous current	The rms value of the instantaneous time current.
Neutral current	Available with a 4-pole breaker
Current maximeter	Maximum value of the instantaneous time current (refreshed every 500 ms) since Trip system installation or last reset.
Demand current ⁽¹⁾	Mean of all instantaneous time current values over a given user-adjustable time interval (e.g. 10 min).
Voltage	The rms value of the voltage.
Average voltage	Average of the 3 phase-to-phase voltages V12, V23 and V31: $V_{avg} = \frac{V_{12} + V_{23} + V_{31}}{3}$
Voltage unbalance	<p>Voltage unbalance on the most unbalanced phase, displayed as a percentage of Vavg.</p>  <p>ETV measures the maximum difference between the instantaneous time voltage of each phase and Vavg, and calculates the voltage unbalance:</p> $V_{unbal} = \frac{ E_{max} }{V_{avg}}$
Instantaneous power	<p>P: total active power Q: total reactive power S: total apparent power P, Q and S are rms instantaneous values.</p>
Power maximeter	Maximum value of the instantaneous time power (refreshed every 1 s) since Trip system installation or last reset.
Demand power ⁽¹⁾	Mean of all instantaneous time power values over a given user-adjustable time interval (e.g. 10 min).
Instantaneous power factor PF	PF = P / S
Total energy	<p>Ep: total active energy Eq: total reactive energy Es: total apparent energy</p>

⁽¹⁾ For details on how demand is calculated, see "Calculating demand values" in the technical appendix page 74.

ETV control units let you access information that can be used to analyse or avoid circuit breaker tripping, thereby increasing the overall availability of your installation. Available information includes the trip history and tripping pre-alarms.

Trip history

The trip history displays the list of the last 10 trips. For each trip, the following indications are recorded and displayed:
 ■ the tripping cause: Ir, I_{sd}, I_i, I_g or Auto-protection (Ap) trips

- List of trip causes:
- overloads (Ir)
 - short-circuits (I_{sd} or I_i)
 - ground faults (I_g)
 - auto-protection (Ap).

The trip history display is presented on page 60.

Pre-alarms

Definition

ETV control units can be set to deliver pre-alarms via their optional M2C contacts (see page 66). These pre-alarms can be used to warn operators that the current is approaching a trip threshold. In this way, remedial measures (e.g. load-shedding, maintenance, etc.) can be taken before the circuit breaker trips, avoiding unnecessary shutdowns.

Two types of pre-alarms are available, depending on the control unit.

- Long-time protection pre-alarm: all ETV control units can be set to deliver a pre-alarm via one of their two outputs when the current reaches 90 % of the long-time protection current setting I_r.
- Ground-fault protection pre-alarm: ETV6.0G control units can also be set to deliver a pre-alarm via one of their two outputs when the current reaches 90 % of the ground-fault protection pickup I_g. Both I_r and I_g pre-alarms can be implemented if neither of the two outputs are required for other functions. See page 62 for general information on output settings (M2C contacts) or page 65 for an example of how to set an output to implement these or other functions.

Operation

The I_r and I_g pre-alarms are delivered via the non-latching outputs (M2C contacts) of ETV control units.

- Pickup (pre-alarm activation): when the current exceeds the pickup threshold (equal to 90 % of the I_r current setting or I_g pickup), the output state changes from 0 to 1 after a time delay of 0.1 second.
- Dropout (pre-alarm deactivation): when the current falls below the dropout threshold (equal to 85 % of the I_r current setting or I_g pickup), the output state returns to 0 after a non-adjustable time delay of 0.1 second and the pre-alarm is automatically deactivated.

Measurements	Pickup (pre-alarm activation)		Dropout (pre-alarm deactivation)	
	Threshold	Time delay	Threshold	Time delay
I _r pre-alarm	90% of I _r	0.1 s	85% of I _r	0.1 s
I _g pre-alarm	90% of I _g	0.1 s	85% of I _g	0.1 s

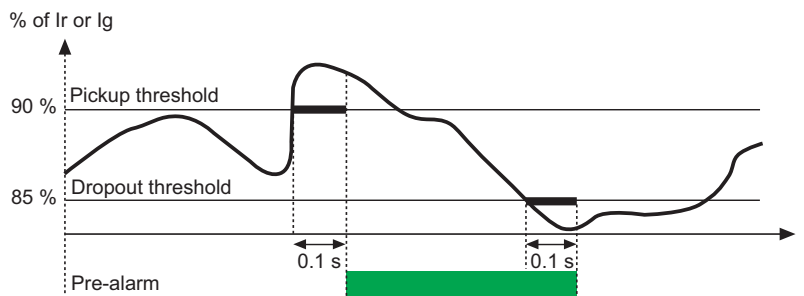

Setting procedure for ET Trip System

Using the adjustment dials

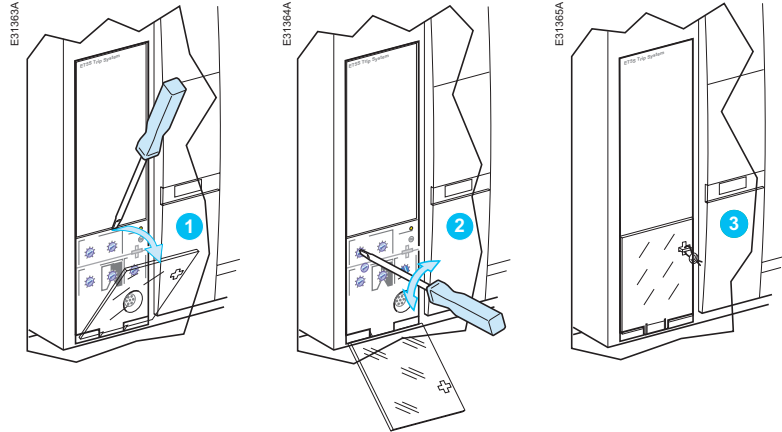

Open the protective cover.

Select the desired setting.

Close the protective cover and, if necessary, install a lead seal to protect the settings.

Setting procedure for ETA/ETV Trip System

1. Open the protective cover.

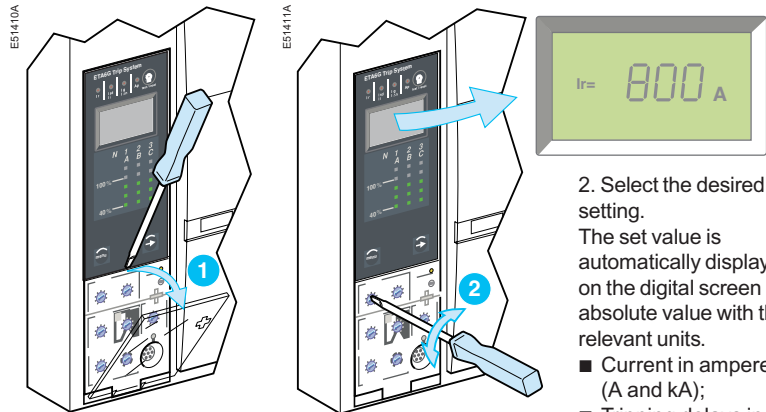

2. Select the desired setting.
The set value is automatically displayed on the digital screen in absolute value with the relevant units.

- Current in amperes (A and kA);
- Tripping delays in seconds.

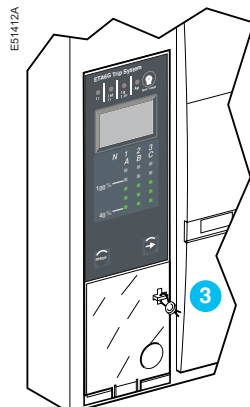

3. If no information is displayed, see the "Digital display". (page 55) If no further action is taken, after a few seconds, the display returns to the main menu for current measurements.

4. Close the protective cover and, if necessary, install a lead seal to protect the settings.

The rating of the circuit breaker in this example is 2000 A.

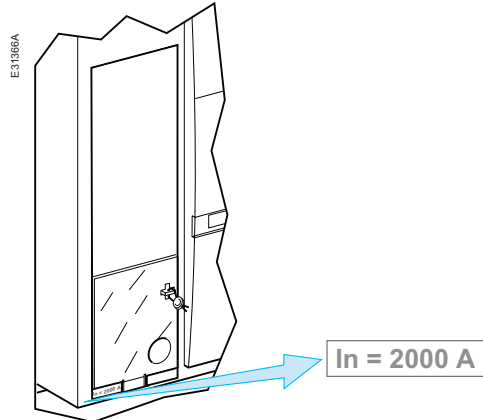

See pages 23 and 24 for information on the available settings.

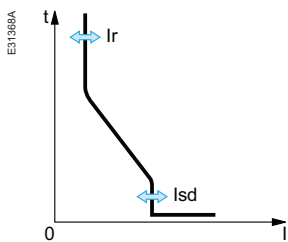

Set the threshold values

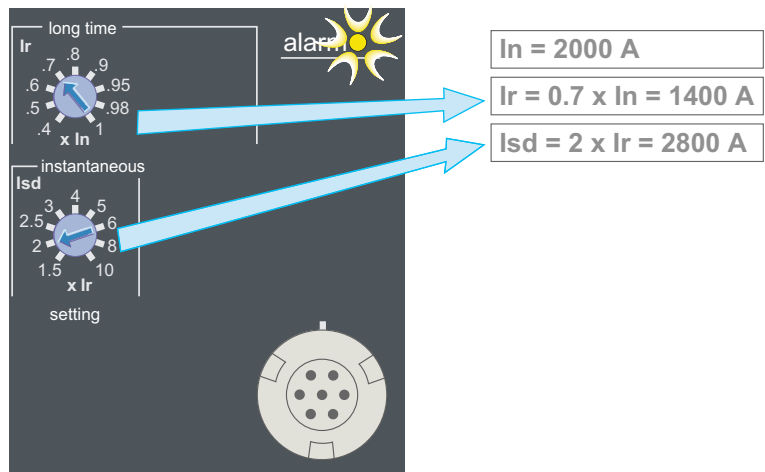

Set the tripping delay

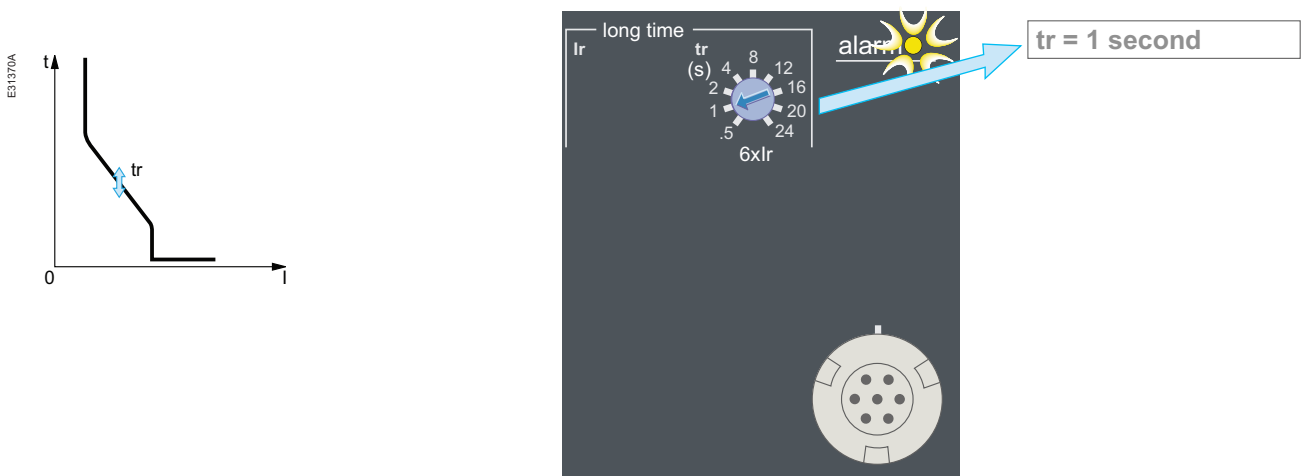

The rating of the circuit breaker in this example is 2000 A.

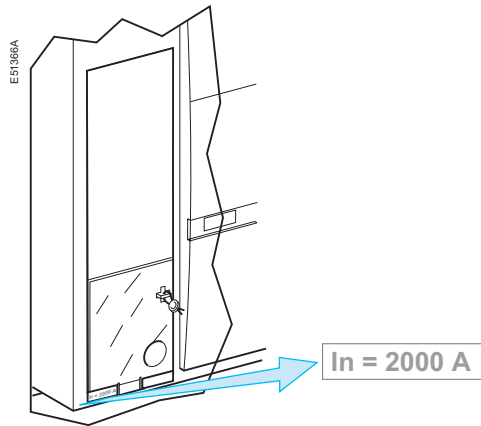

See pages 23 and 24 for information on the available settings.

Set the threshold values

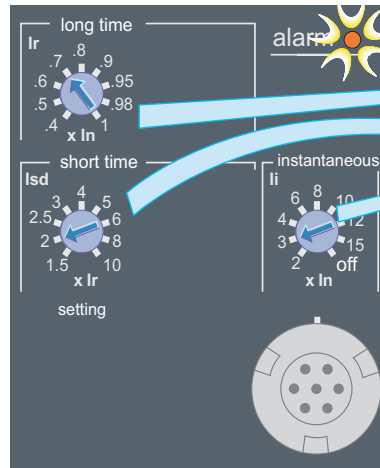
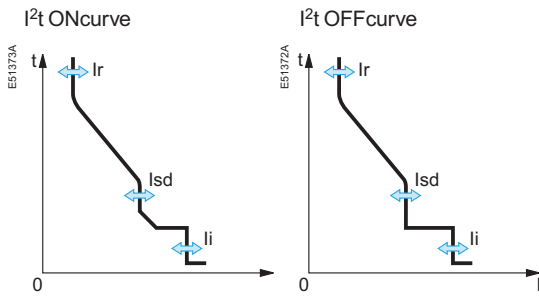

- $I_n = 2000 \text{ A}$
- $I_r = 0.7 \times I_n = 1400 \text{ A}$
- $I_{std} = 2 \times I_r = 2800 \text{ A}$
- $I_i = 3 \times I_n = 6000 \text{ A}$

Set the tripping delay

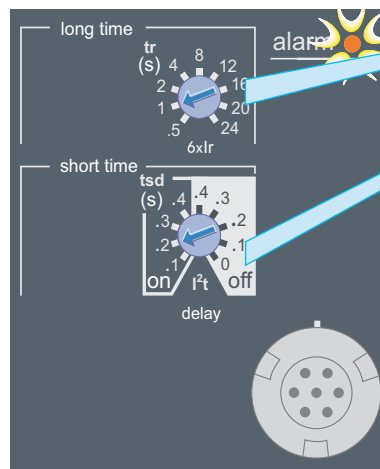
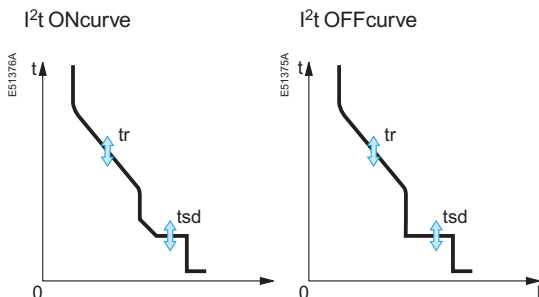

$t_r = 1 \text{ second}$

$t_{sd} = 0.2 \text{ seconds}$



The rating of the circuit breaker in this example is 2000 A.

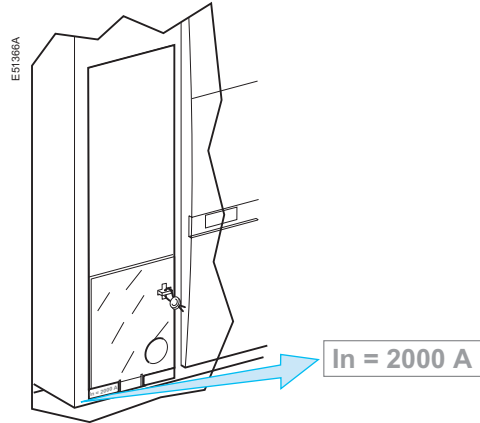

See pages 23 and 24 for information on the available settings.

Thresholds

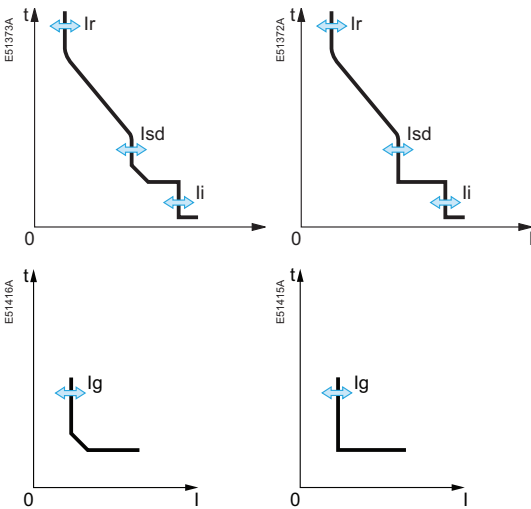

Set the threshold values

- $I_n = 2000 \text{ A}$
- $I_r = 0.7 \times I_n = 1400 \text{ A}$
- $I_{sd} = 2 \times I_r = 2800 \text{ A}$
- $I_i = 3 \times I_n = 6000 \text{ A}$
- B → $I_g = 640 \text{ A}$

Tripping delays

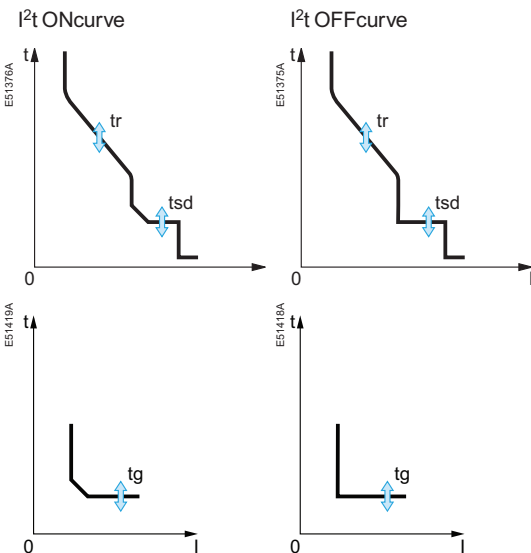

Set the tripping delay

- $t_r = 1 \text{ s}$
- $t_{sd} = 0.2 \text{ s}$
- $t_g = 0.2 \text{ s}$

Selecting the type of neutral protection

On four-pole circuit breakers, it is possible to select the type of neutral protection for the fourth pole using the three-position dial on the circuit breaker:

1. neutral unprotected (4P 3D);
2. neutral protection at 0.5 In (3D + N/2);
3. neutral protection at In (4P 4D).

The factory default setting is 3D+N/2.

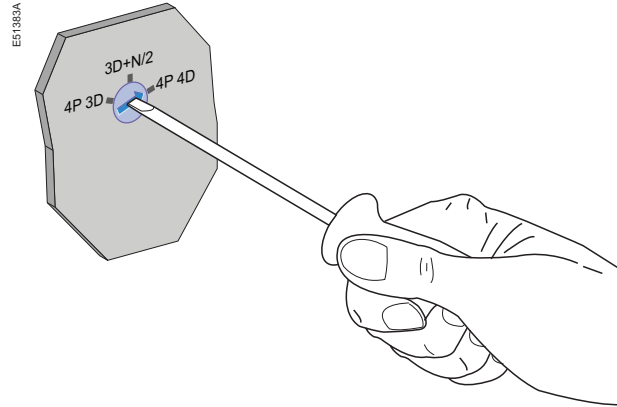

Caution!
With the 4P 3D setting, the current in the neutral must not exceed the rated current of the circuit breaker.

Type of neutral	Description.
Neutral unprotected	The distribution system does not require protection of the neutral conductor.
Neutral protection at 0.5 In	<p>The cross-sectional area of the neutral conductor at 0.5 In is half that of the phase conductors.</p> <ul style="list-style-type: none"> ■ the long-time current setting I_r for the neutral is equal to half the setting value ■ the short-time pick-up I_{sd} (5S/6G) for the neutral is equal to half the setting value ■ the instantaneous pick-up I_{sd} (2I) for the neutral is equal to half the setting value ■ the instantaneous pick-up I_i (5S/6G) for the neutral is equal to the setting value.
Neutral protection at In	<p>The cross-sectional area of the neutral conductor is equal at In to that of the phase conductors.</p> <ul style="list-style-type: none"> ■ the long-time current setting I_r for the neutral is equal to the setting value ■ the short-time pick-up I_{sd} (5S/6G) for the neutral is equal to the setting value ■ the instantaneous pick-up I_{sd} (2I) and I_i (5S/6G) for the neutral are equal to the setting value.

The procedure for resetting the circuit breaker following a fault trip is presented in Page No.10.

Resetting the fault indications

- determine why the circuit breaker tripped.
The fault indication is maintained until it is reset on the control unit.
- press the fault-trip reset button.

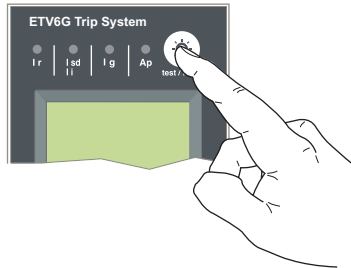

- check the parameter settings of the control unit.

Checking the battery

ET Trip System

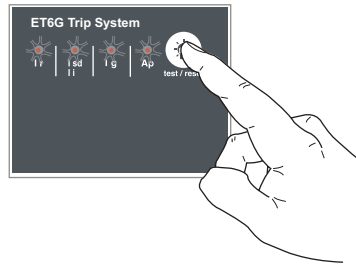

ETA/ETV Trip System

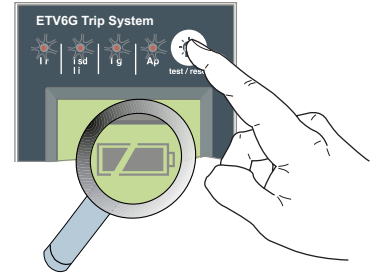

Press the battery-test button (same as the fault-trip reset button) to check the battery status by the luminance of trip indicator light.

ET Trip System

If trip indicators became dim or no luminance, the battery should be changed.

ETA/ETV Trip System

- Battery fully charged
- Battery half charged
- Change the battery

If the battery needs to be changed, order a new battery with the Schneider catalogue number 33593.

1. lithium battery
2. 1.2 AA, 3.6 V, 850 mA/h
3. SAFT LS3 SONNENSCHN TEL-S

Changing the control-unit battery

1. Remove the battery cover.
2. Remove the battery.

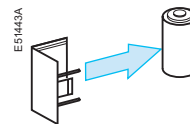
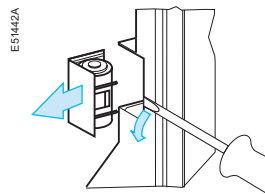

3. Insert a new battery.
Check the polarity.

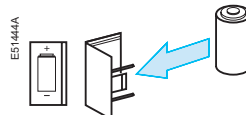

4. Put the cover back in place.
Press the battery-test button to check the new battery.

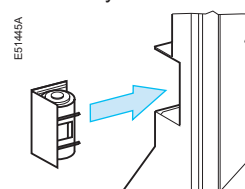

Charge and close the circuit breaker.
Using a screw driver, press the test button for ground-fault protection. The circuit breaker should open.

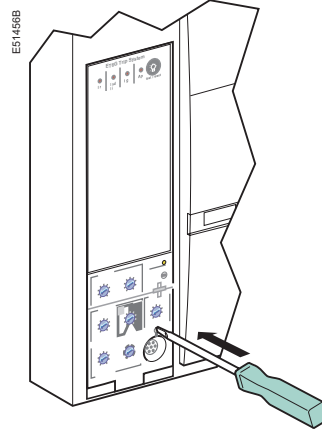

If the circuit breaker does not open, contact the Schneider after-sales support department.

Symbols used:



Briefly press a key.



Press and hold a key.

It is possible at any time to stop consulting a current measurement, a maximum current value recorded by the maximeter or the setting values. After a few seconds, the ETA Trip System automatically returns to the main menu displaying the current value of the most heavily loaded phase.

The protection setting can be displayed directly on the digital display.

Three menus may be accessed on ETA Trip System, providing the following information:

- phase current measurements I1, I2, I3, neutral IN, ground-fault current Ig on the ETA6G trip system.
- maximeter current values for phases I1, I2, I3, neutral IN, the maximum ground-fault current Ig on the ETA6G Trip System.
- protection settings and tripping delays.

1. Measurements

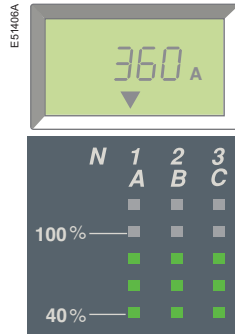

Press the "menu" button to access the maximum current values measured by the maximeter.

2. Maximeter

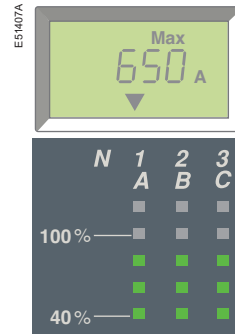

Press the "menu" button to access the protection settings and tripping delays.

3. Settings

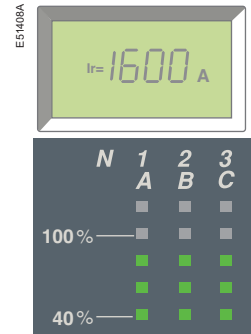

Press the "menu" button to return to the current measurements.

4. The system returns to the main "Measurements" menu.

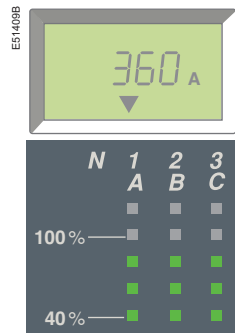

Current values may be read in the "Measurements" menu, which is also the main menu.

If no particular action is taken, the system displays the current value of the most heavily loaded phase.

"Measurements" menu
Phase 1 is the most heavily loaded.

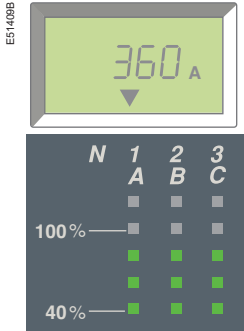

Display of current I1

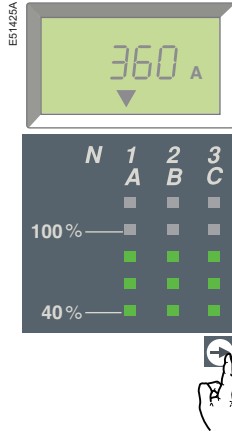

Press the "arrow" button to go on to current I2.

Display of current I2

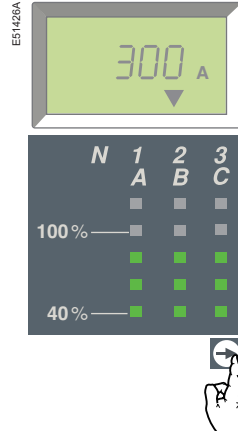

Press the "arrow" button to go on to current I3.

Display of current I3

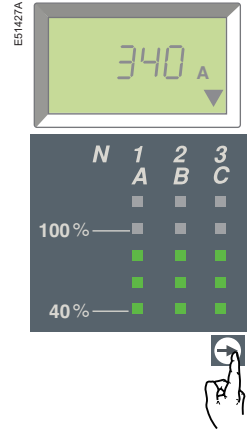

Press the "arrow" button to go on to current IN if the neutral is protected.

Display of current IN

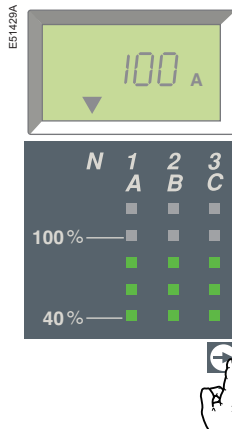

Press the "arrow" button to go on to the groundfault current I_g

Display of current I_g (ETA 6G)

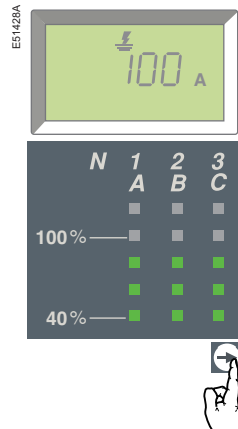

Press the "arrow" button to return to current I1

The system returns to the display of current I1

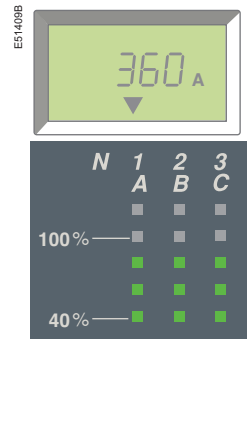

Resetting the maximum current values

Maximum current values can be reset using the "Maximeter" menu.

If no particular action is taken, the system returns to the main menu.

"Maximeter" menu.

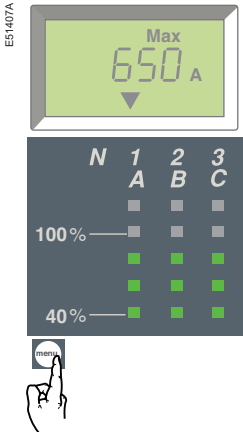

Select the maximum current value to be reset (e.g. I2 max.).

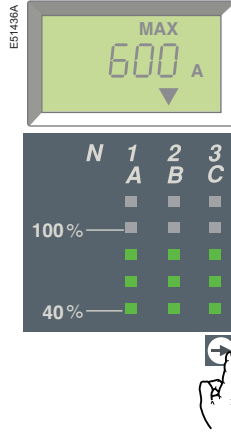

Press the "arrow" button as many times as required to select I2 max.

Reset.

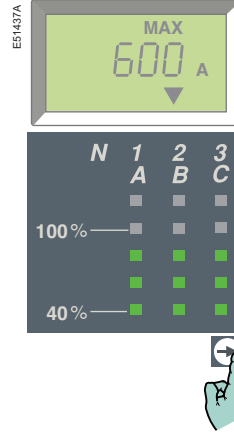





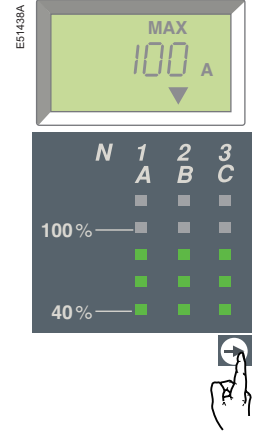



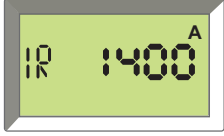

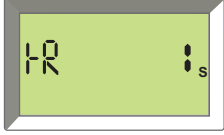

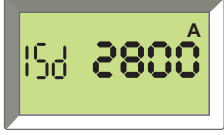

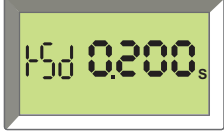

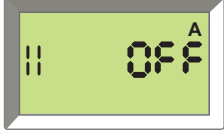

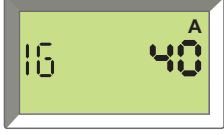
Press and hold the "arrow" button down for three to four seconds. The current value flashes during the reset, then changes to the present value (the new maximum).

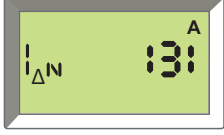
Select another value to reset or return to the main menu.

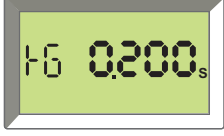

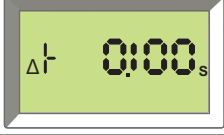

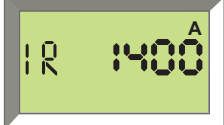
Press the "arrow" button as many times as required to select another maximum value to reset or return to the main menu.



	ETA2I	ETA5S	ETA6G		
Long-time current setting I_R				 Select the "Settings" menu. The I_R value is displayed first.	
Long-time tripping delay t_R				 Press the "arrow" button to go on to the t_R value.	
Short-time pick-up I_{sd}				 Press the "arrow" button to go on to the short-time I_{sd} value.	
Short-time tripping delay t_{sd}				 Press the "arrow" button to go on to the t_{sd} value.	
Instantaneous pick-up I_i				 the instantaneous I_i value.	
Ground-fault pick-up I_g				 Press the "arrow" button to go on to the I_g value. or	
Earth-leakage pick-up $I_{\Delta n}$				 the $I_{\Delta n}$ value.	
Ground-fault tripping delay t_g				 Press the "arrow" button to go on to the t_g value. Or	
Earth-leakage tripping delay Δt				 the Δt value.	
				 Press the "arrow" button to return to the beginning of the menu.	





Definitions

- ETV has two display modes: Tree Navigation and Quick View modes.

Tree Navigation mode

- Tree Navigation is a manual scroll mode using the  and  buttons on a ETV control unit.
- All information can also be viewed on a PC using the communication option (see table page 66).
- Two navigation trees are provided for each Trip System control unit:
 - a Display tree to view the main values and settings of the control unit
 - a Setting tree to modify the settings.

You can enter the Setting tree from any screen of the Display tree by pressing the  and  buttons simultaneously.

- Each tree is divided up into several branches (see opposite page). Use the  button to scroll through the different branches of a tree. When on the last branch, pressing the  button returns you to the instantaneous I1 current screen of the Display tree.
- Each branch provides access to values or settings that depend on the type of Trip System control unit, for example:
 - measurements (instantaneous current, demand current, maximum instantaneous, current, voltage, power, energy, etc.)
 - trip history
 - protection setting display
 - settings (for modification of communication, measurement or output parameters).
- Use the  button to scroll through the different screens of a given branch. Press the  button at any time to proceed to the next branch.

- All the screens of the ETV navigation trees are detailed on page 57.

Quick View mode

- ETV also offers a Quick View display mode.
- This mode can be used to let the display automatically scroll through up to 10 screens.
- An override function is available to allow manual scrolling.
- Quick View is the factory-set display mode for ETV. You can easily switch between Quick View and Tree Navigation modes by briefly pressing the  button.
- You can modify the Quick View screens defined in the default configuration and the screen display time.

HMI display modes

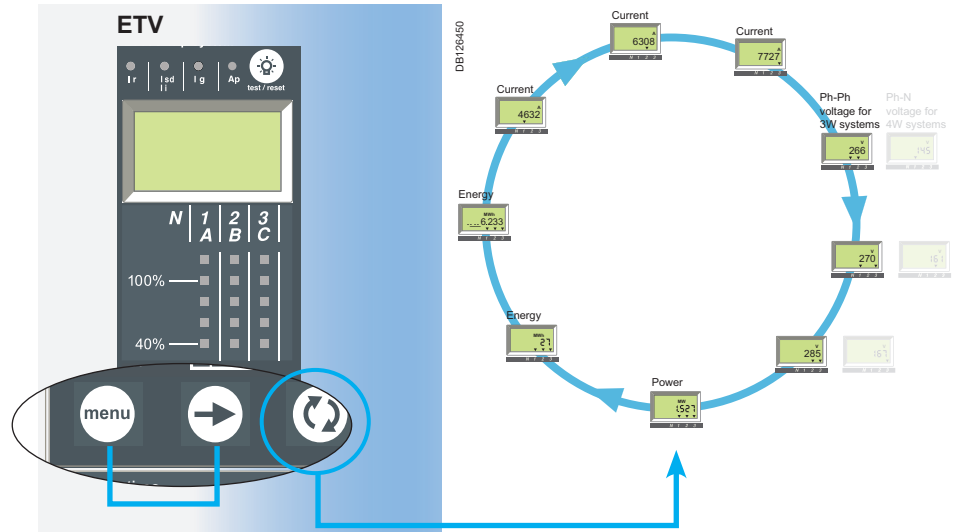

Quick View

You can enter the Setting tree from any screen of the Display tree by pressing the **menu** and **→** buttons simultaneously.

ETV display tree

Instantaneous and demand current

Max. of instantaneous current

Voltage

Power

Active energy

Trip history

Protection setting display

ETV setting tree

Communication settings

Measurement settings

Output settings (with optional M2C contacts)

Software version

Quick View allows the operator to quickly view the most important electrical measurements (currents, voltages, active power, energy) without having to touch the control unit keypad.

The screens automatically scroll in a circular manner so that the operator can view all the main electrical measurements one after another. The current bargraph and overload LED remain visible at all times in Quick View mode.

Quick View screen descriptions

Quick View can be used to display the screens defined in:

- the factory configuration
- a custom configuration.

Screens defined in the factory configuration

ETV control units come with a factory Quick View configuration including the following 9 screens, scrolled in the indicated order:

1. Current of phase 1/A
2. Current of phase 2/B
3. Current of phase 3/C
4. Voltage: phase-to-neutral (V1N) or phase-to-phase (V12)
5. Voltage: phase-to-neutral (V2N) or phase-to-phase (V23)
6. Voltage: phase-to-neutral (V3N) or phase-to-phase (V31)
7. Total active power
8. Active energy: whole number part (up to 6 digits) in MWh
9. Active energy: last digit of whole number part plus 3 digits of decimal part

Each screen is displayed for 2 s before being replaced by the next in the list. This duration can be adjusted from 1 s to 9 s in 1 s steps (see "Measurement settings - Quick View display duration" on page 62).

DB126520

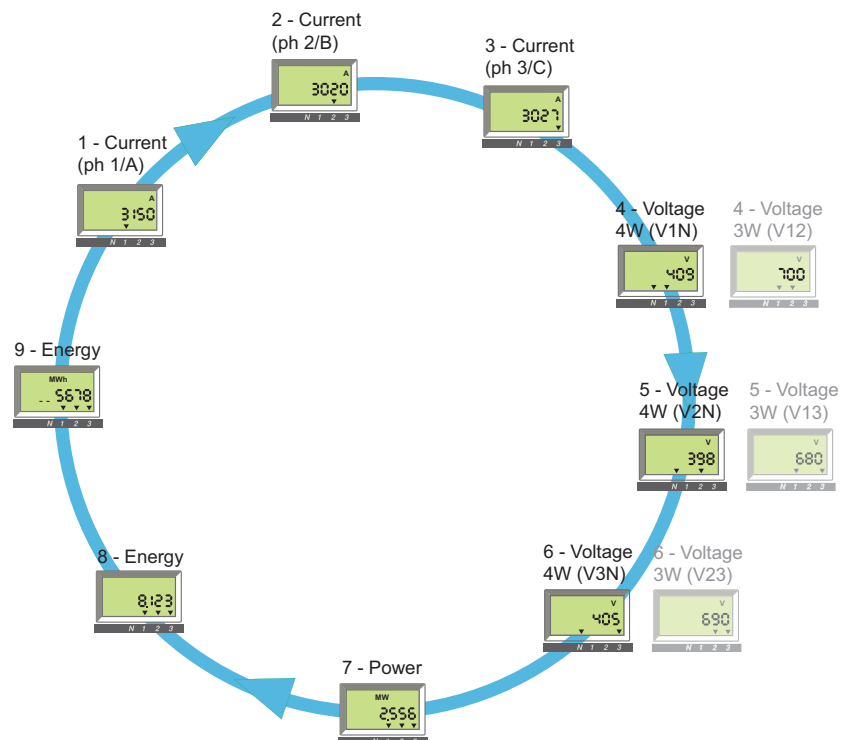

Activating / Deactivating Quick View

- When energised for the first time, ETV automatically activates Quick View and scrolls through the factory-configured screens.
- Press the  button briefly (<1 s) to activate the classical tree navigation mode. Press again briefly (<1 s) to return to Quick View mode.
- In both Tree Navigation and Quick View modes, the first screen displayed is screen 1, but in tree navigation mode, finally the screen changes to display the instantaneous current of the most heavily loaded phase.

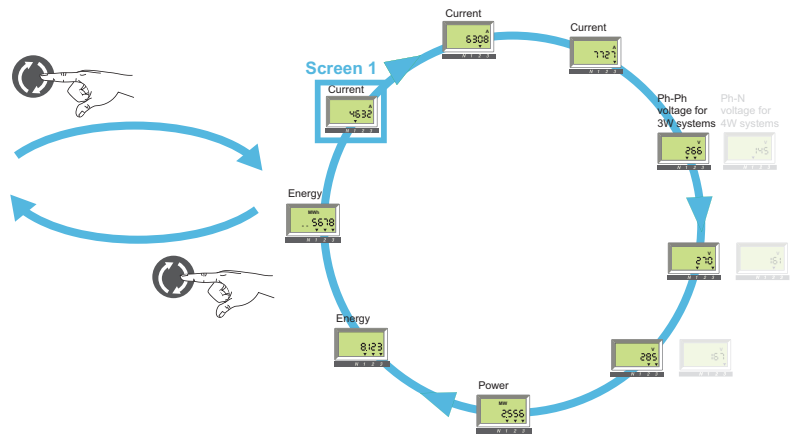
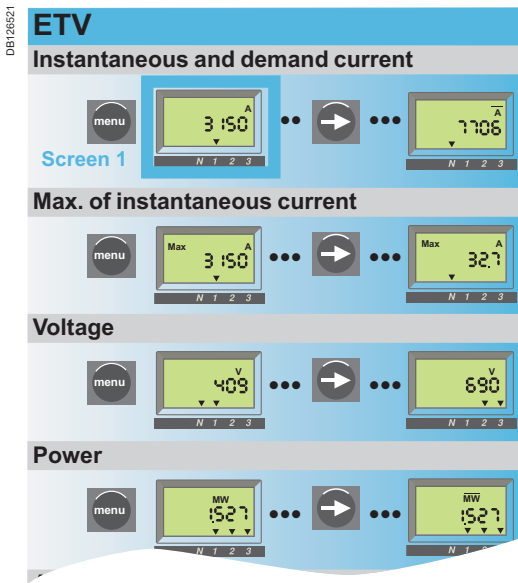

Manual control of Quick View scrolling

Automatic scrolling of Quick View screens can be stopped, for example to display a screen for more than 2 seconds in order note measurements.



Press briefly
(< 1 s)

Stops scrolling and displays the present screen for 20 s if no other action is taken.

It is then possible to manually scroll through each Quick View screen one after the other.



Press briefly
(< 1 s)

Displays the next screen for 20 s if no other action is taken.

Returning to automatic scrolling

After a period of 20 s with no action, automatic scrolling is automatically reactivated.

Events causing the interruption of automatic scrolling

Automatic scrolling of Quick View screens is also interrupted by the following events:



- tripping (interrupted until the trip is reset by pressing the  button)
- change in a protection setting
- battery test (while the test button is pressed).

Custom Quick View configuration

- The Quick View factory configuration includes the 9 screens presented on the page 53.
- It is possible to change some or all of the screens of the factory configuration.
- Quick View can scroll through up to 10 screens.
- If all Quick View screens are removed, pressing the  button briefly will have no effect. The display remains in Tree Navigation mode.

Removing a screen

To remove a screen from Quick View:

- make sure you are in manual control of the quick view mode, and if necessary, press the  button briefly (< 1 s) to activate automatic scrolling and then press the  button briefly (<1s) to activate the manual control of the quick view mode



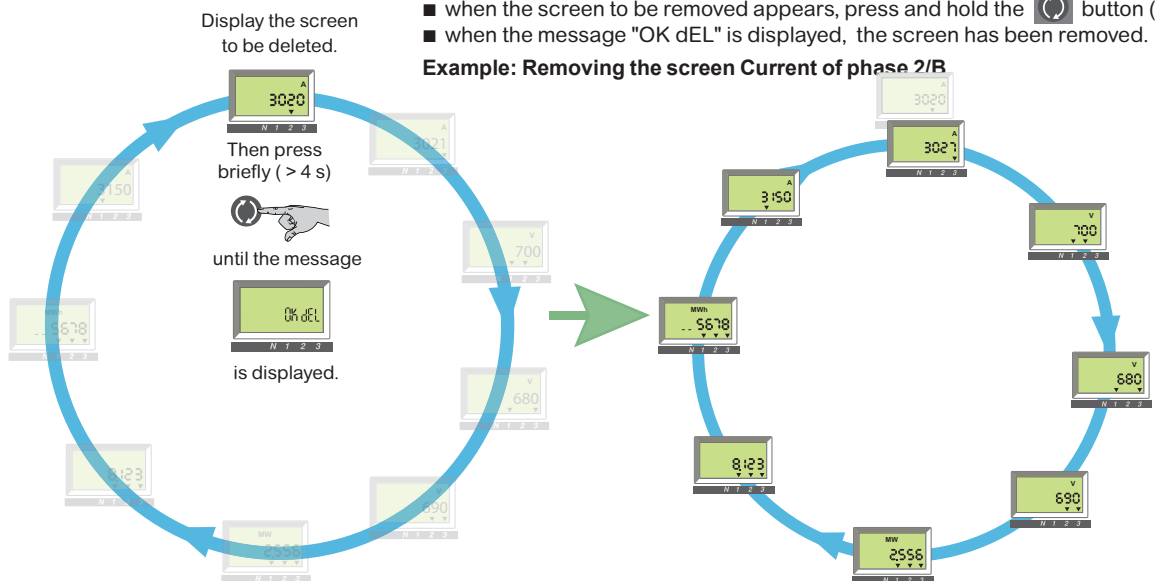

- when the screen to be removed appears, press and hold the  button (> 4 s)
- when the message "OK dEL" is displayed, the screen has been removed.

Example: Removing the screen Current of phase 2/B



Adding a screen

To add a screen (selected from the navigation tree):

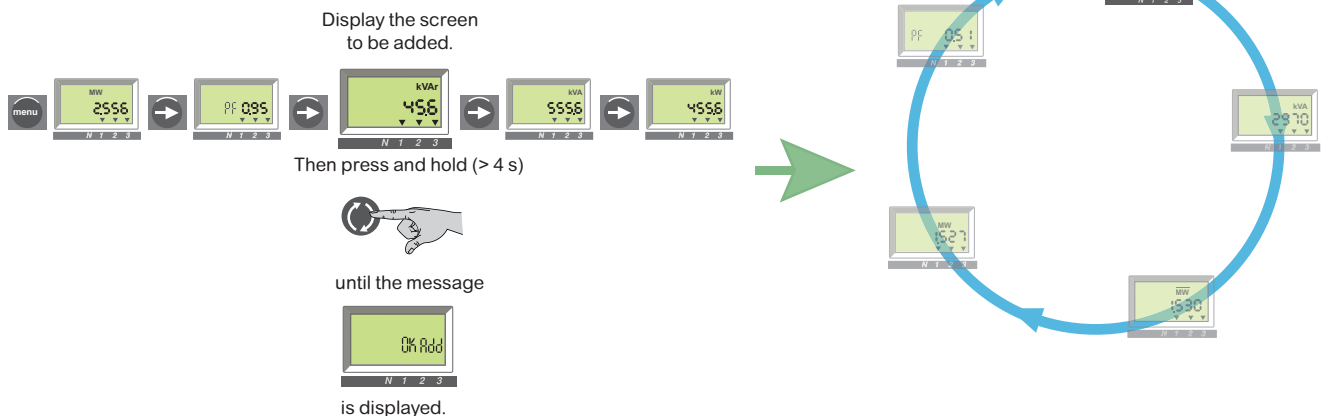

- access Tree Navigation mode by briefly pressing the  button (< 1 s)
- in this mode, display the screen you want to add using the  and  buttons, as described in "Tree Navigation" on page 56.
- when the selected screen is displayed, press and hold the  button (> 4 s)
- when the message "OK Add" is displayed, the screen has been added to the Quick View configuration. It will be placed in the last Quick View position.



- if you try to add a screen to an existing configuration that already has 10 screens, the message "QV full" will be displayed.

Tree Navigation

■ The classical navigation trees presented in the "HMI introduction" on page 52 provide access to all the screens of ETV control units.

■ The different screens are accessible using the  and  buttons and are organised in branches corresponding to a given type of information.

The following branches are available, in the indicated order, depending on the type of Trip System control unit:

Branch (type of information)	ETV
Display tree	
Instantaneous current	
Instantaneous and demand current	■
Maximeters for instantaneous current	■
Voltage	■
Power (total of 3 phases)	■
Active energy (total of 3 phases)	■
Trip history (last 10)	■
Protection setting display	■
Setting tree	
Communication settings	■
Measurement settings	■
Output settings (with optional M2C contacts)	■
Software version	■

Navigating with the keypad buttons

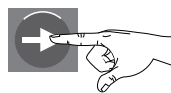

Press briefly
(< 1 s)
(symbol: a **white hand**)

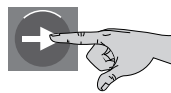

Press and hold
(> 4 s)
(symbol: a **grey hand**)

Screen information

The positions of the downward arrows (one, two or three arrows) under the information displayed on the screen indicate the phases concerned, as shown for example in the screens below.

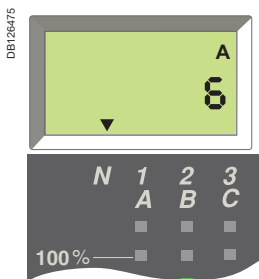

6 A current in the neutral
(arrow above the N).

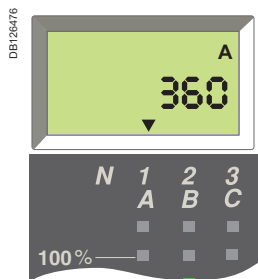

360 A current in phase 1/A
(arrow above 1/A).

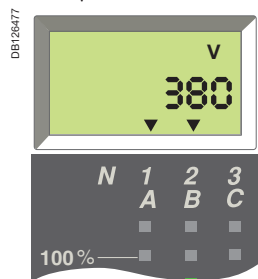

380 V phase-to-phase voltage between phases 1/A and 2/B
(arrows above 1/A and 2/B).

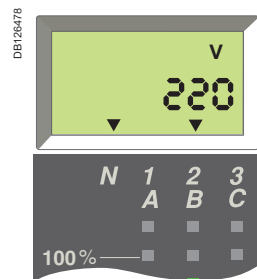

220V phase-to-neutral voltage between phase 2/B and neutral
(arrows above N and 2/B).

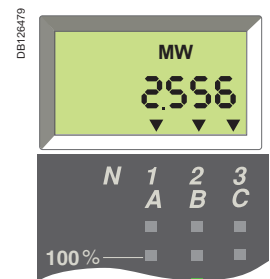

2.556 MW total active power of the 3 phases
(arrows above the 3 phases).

If no particular action is taken, the system displays the instantaneous current of the most heavily loaded phase.





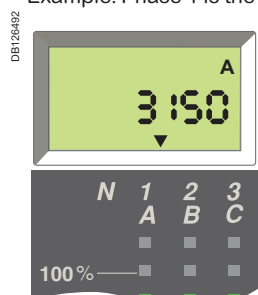



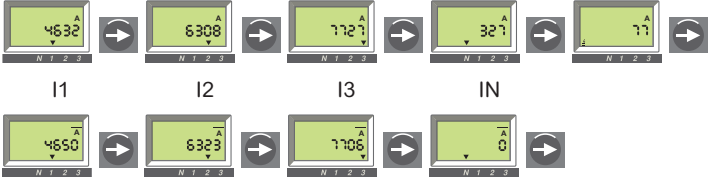

Default screen

Example: Phase 1 is the most heavily loaded.

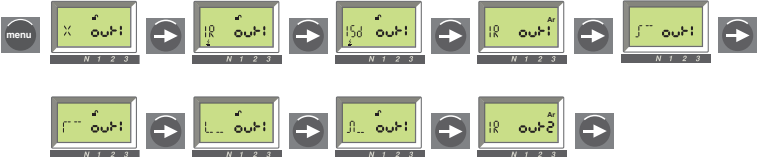

Tree Navigation mode ETV menu display

The figures below show all the screens of the 2 ETV **navigation trees** with all details concerning screen content and navigation between the various branches and screens of the trees.

Display tree branches	Screens
Default display (instantaneous current of the most heavily loaded phase)	
Instantaneous and demand currents	I1 I2 I3 IN Ig (ETV6G) 
Instantaneous current maximeters To reset current maximeters, see page 59.	I1 I2 I3 IN Ig (ETV6G) 
Voltages (3-wire systems)	V12 V23 V31 
Voltages (4-wire systems)	V1N V2N V3N V12 V23 V31 
Power Active Power is displayed positively or negatively according to the parameter Power sign (see page 62).	P PF Q S Demand P 
Active energy Ep is displayed in MWh on 2 screens, see details on page 58. To reset active energy, see page 27.	Ep (MWh) Ep (MWh) 
Trip history (see details on page 60)	The trip history displays the list of the last ten trips.
Protection settings display (see details on page 61)	The protection settings displayed depend on the model of the ETV control unit.
Setting tree branches	Screens
Communication settings (see details on page 62)	
Measurement settings (see details on page 62)	
Output settings (with optional M2C contacts) (see details on page 62)	
Software version	

Tree Navigation mode

Displaying total active energy

Energy

The total active energy (Ep) consumed since Trip System energisation is displayed on 2 screens:

- the first screen displays the whole number part of total energy in MWh
- the second screen displays the decimal part of total energy in MWh.

Example: display of Ep = 26.233 MWh (26233 kWh)



Display of whole number part of total energy in MWh (up to 6 digits)

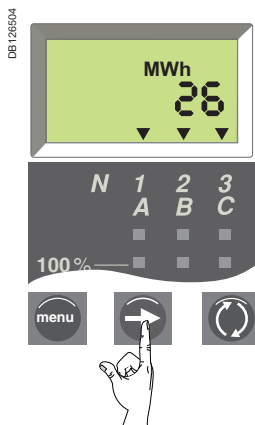

Press the "Arrow" button to go to screen for the decimal part.

Display of decimal part of total energy in MWh (up to 3 digits after the decimal preceded by the last digit of the whole number part)



Press the "Arrow" button to go to screen for the whole number part.

The total active energy (Ep) is calculated and displayed positively whatever the value of the parameter Power sign. The Maximum totale active energy displayed is 999 999 999 MWh. If the total active energy keeps increasing, the value displayed is 999 999 999 MWh.

Tree Navigation mode

Resetting current maximeters and total active energy

Resetting the maximum current values

Reset of the corresponding memory register.



Select the maximum current value to be reset (e.g. I2 max.)



Press the "Arrow" button as many times as required to access the I2 max. screen.

Reset



Press and hold the "Arrow" button down for 3 to 4 seconds. The old value changes to the present value (the new maximum).

Select another value of current to reset or return to the main menu



Press the "Arrow" button as many times as required to select another maximum value to reset or return to the main menu.

Resetting the total active energy (ETV)



Select the active energy screen

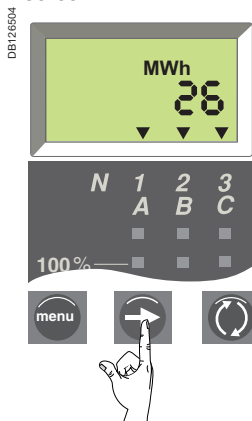

Press the "Arrow" button as many times as required to access the total active energy screen (displaying the whole number part of the total active energy).

Reset

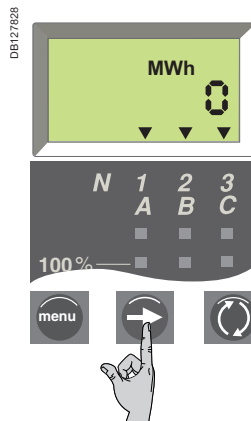

Press and hold the "Arrow" button down for 3 to 4 seconds. The old value changes to the new value (starting at 0) when releasing the button.

Return to the main menu



Press the "Menu" button to return to the main menu.

Tree Navigation mode

Displaying the trip history

Introduction

The trip history displays the list of the last 10 trips.

For each trip, the following indications are recorded and displayed:

- the tripping cause: Ir, I_{sd}, I_i or Auto-protection (Ap) trips
- the date and time of the trip (requires communication option in order to set date and time).

Example 1: Display for the first (most recent) trip of the five trips recorded in the trip history.



Ir: tripping cause.
 1: symbol indicating trip history display
 1: trip number (1 being the most recent)
 5: total number of trips recorded.

Example 2: Display for the ninth trip of the ten trips recorded in the trip history.



Ii: tripping cause.
 9: symbol indicating trip history display
 9: trip number (1 being the most recent)
 10: total number of trips recorded.

List of trip screens for the various causes

Cause	Comment	Screen display
Ir trip	Long-time protection	
I _{sd} trip	Short-time protection	
I _i ⁽¹⁾ trip	Instantaneous protection	
I _g trip	Ground-fault protection	
Ap trip	Auto-protection	

⁽¹⁾ Instantaneous protection trips (I_i) are indicated on the trip history screen in the same way as short-time protection trips (I_{sd}). Both are caused by short-circuits.

Trip date and time











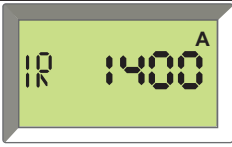







For each trip history screen, ETV will display the date and time of the trip. Every time the 24 VDC control voltage is energised, date and time restart at January first 2000. Therefore, it is strongly recommended to set date and time periodically (at least once an hour).

The setting of the ETV date and time requires the communication option and can be set by a supervision software:

2 screens (date and time) will be displayed successively when the button is pressed:

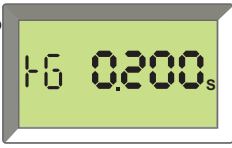

In this example, date is January third 2011 and time is 12 h 34 min and 56 s.

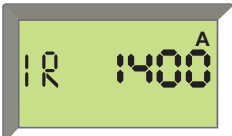
	ETV2I	ETV5S	ETV6G			
DB119483 Long-time current setting I_r					Select the "Settings" menu. The I_r value is displayed first.	
Long-time tripping delay t_r					Press the "arrow" button to go on to the t_r value.	
Short-time pick-up I_{sd}					Press the "arrow" button to go on to the short-time I_{sd} value.	
Short-time tripping delay t_{sd}					Press the "arrow" button to go on to the t_{sd} value.	
Instantaneous pick-up I_i					the instantaneous I_i value.	
Ground-fault pick-up I_g					Press the "arrow" button to go on to the I_g value. or	
Earth-leakage pick-up $I_{\Delta n}$					the $I_{\Delta n}$ value.	
Ground-fault tripping delay t_g					Press the "arrow" button to go on to the t_g value. Or	
Earth-leakage tripping delay Δt					the Δt value.	
					Press the "arrow" button to return to the beginning of the menu.	

Set-up parameters

ETV has three types of set-up parameters:

- communication settings
- measurement settings
- M2c output settings.

The corresponding parameters (Address, Baud rate, etc.) have default values that can or must be changed according to the needs of the installation or users.

The following table lists these parameters and indicates their possible values.

The procedure to change the settings is described on the next page.

The parameters are displayed in the order indicated in the table below.

Parameters	Definition	Format (X = digit)	Default value (units)	Default screen (2)	Possible values
Communication settings (1) for ETV with communication option (Modbus network)					
Modbus address	Address of ETV on the Modbus network to which it is connected.	XX	47		1 to 47
Baud rate	Number of kbits exchanged per second (kbauds on the Modbus network).	XX.X	19.2 (kb)		4.8 9.6 19.2
Parity	Used for error checking based on the number of bits in the transmitted data group.	E or n	E		E (Even) n (None)
Modbus connection	Type of Modbus connection: 4-wire (4) or 2-wire + ULP (ULP)	4 or ULP	4		4 ULP
Measurement settings					
Interval (window) for demand power calculation	Period of time over which the demand power is calculated.	XX	15 (minutes)		5 to 60 (in 1 minute steps)
Interval (window) for demand current calculation	Period of time over which the demand current is calculated.	XX	15 (minutes)		5 to 60 (in 1 minute steps)
Type of network (3-wire or 4-wire) and number of circuit breaker poles (CTs).	<ul style="list-style-type: none"> ■ Setting 43 = 4-wire (3ph+N) and 3-pole CB (3 CTs) (3) ■ Setting 44 = 4-wire (3ph+N) and 4-pole CB (4 CTs) or 3-pole CB (3 CTs) + external CT ■ Setting 33 = 3-wire (3ph) and 3-pole CB (3 CTs) (4) 	XX	43		43 44 33
Power sign	By default, the ETV considers power flowing into the circuit breaker via the top terminals to loads connected to the bottom terminals as positive (top fed).	+ or --	+		+ --
Quick View display duration	Duration of display of each screen in Quick View mode	()	2 (s)		1 to 9
Output settings for ETV with optional M2C contacts					
Output	Two outputs are available via the 2 optional M2C contacts: ■ Out 1 and Out 2. Setting possibilities are the same for both.				Out 1 Out 2
Event assigned to the output	Various events can be assigned to each output: <ul style="list-style-type: none"> ■ 3 trip events: <ul style="list-style-type: none"> <input type="checkbox"/> tripping caused by Ir <input type="checkbox"/> tripping caused by Isd or li <input type="checkbox"/> tripping caused by Ig (ETV6G) ■ 2 pre-alarm events: <ul style="list-style-type: none"> <input type="checkbox"/> Ir pre-alarm <input type="checkbox"/> Ig pre-alarm (ETV6G) 			 	Not assigned Ir trip Isd (includes li) trip Ig trip (6.0 E) Ir pre-alarm Ig pre-alarm (6.0 E)
Output state	The output state (normally "0") can be controlled in three ways: <ul style="list-style-type: none"> ■ forced to 1 (for testing) ■ forced to 0 (for testing) ■ changed from 0 to 1 (without latching) on occurrence of the assigned event (normal mode) 			 	Forced to 1 Forced to 0 Normal mode (no latching)

(1) When the communication option is used, the communication parameters must be set. The communication module should be set up only when installed. Modification of a parameter on a system already in operation may lead to communication faults. (2) Note that all the default screens include a closed padlock icon . This means the value is protected. You must open the padlock to modify the settings and close the padlock after your modification in order to protect the new value. The procedure is described on the next page. (3) Important: for 3-pole circuit breakers used on 4-wire systems (3ph + N), terminal VN on the Trip system control unit must always be connected to the neutral. If this is not done, the phase-to-neutral voltage measurements can be erroneous. (4) Important: for 3-pole circuit breakers used on 3-wire systems (neutral not distributed), always set this value to 63 (see below) to avoid indications of a meaningless phase-to-neutral voltage.

General procedure to set ETV parameters

The parameters are divided into three branches on the navigation tree:

- communication settings
- measurement settings
- output settings.

The following describes the general procedure to modify the settings. The next two pages give examples for the Modbus address and output settings.

Accessing the first screen of the communication settings branch

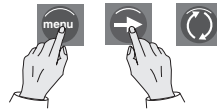

Simultaneously press and hold (four seconds) the "menu" and "arrow" buttons to access the first communication settings screen. The present value is displayed. A closed padlock icon indicates that the setting is locked.

Unlocking and accessing the setting to be changed (flashing)



Press the "Quick View" button to open the padlock. The setting to be changed (or the first digit) will flash, indicating that it is ready to be modified.

Selecting the new setting



Press the "Quick View" button to select the new setting. The possible settings are scrolled in a loop. Each press increments to the next setting or choices in the loop.

Confirming and locking the new setting

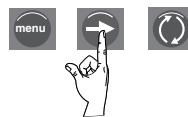

Press the "arrow" button to confirm the new setting. It stops flashing and a closed padlock is displayed.

For a two-digit setting, this operation sets the first digit and the second digit flashes to indicate it is ready to be modified. Proceed as above to change it, then press the "menu" button to validate the new two-digit setting. It stops flashing, and a closed padlock is displayed.



Press the "arrow" button to go to the screen for the next parameter in the communication settings branch. To go to the next branch (measurement settings), press the "menu" button.

Note: Within a given branch, the various parameters are organised in a loop. You must scroll through all the parameters of the branch using the "arrow" button to return to the same parameter. To proceed to the next set-up branch (or exit the last branch), press the "menu" button.

Example 1: Setting the Modbus address

The Modbus address is a two-digit number identifying the ETV in a Modbus network.



Access the existing Modbus address

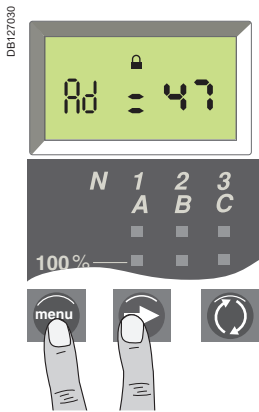

Simultaneously press the and the buttons for four seconds to access the address setting screen. The existing address is displayed (default address 47 or XX). A closed padlock icon indicates that the value is locked.

Unlock and access the first digit (flashing)

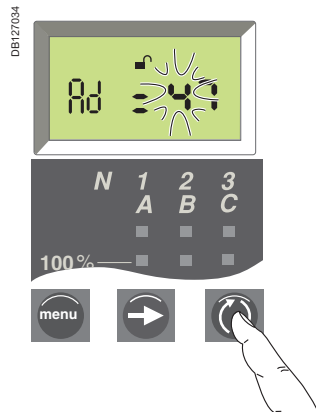

Press the button to open the padlock and display the first digit (e.g. 4). It will flash, indicating it is ready to be modified.

Modify the first digit

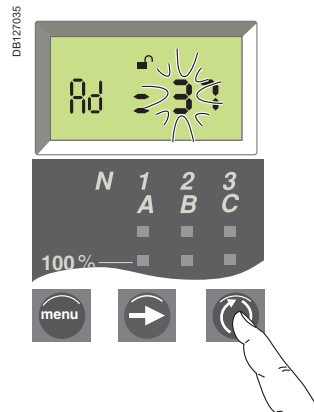

Press the button repeatedly until the new value for the first digit is displayed. You can scroll through all possible values in a loop ⁽¹⁾.

Confirm the first digit and access the second digit (flashing)

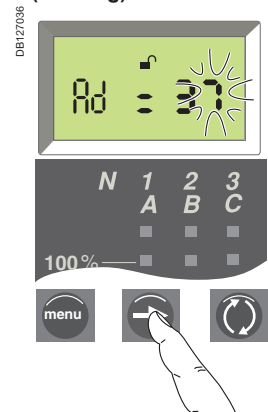

Briefly press the button to display the second digit. The digit will stop flashing and the second digit will start flashing, indicating it is ready to be modified.

Modify the second digit

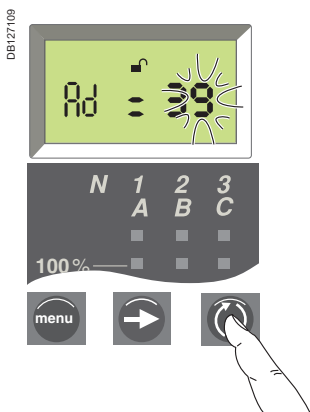

Press on the button repeatedly until the new value for the second digit is displayed. You can scroll through all possible values in a loop, as for the first digit.

Confirm and lock the new setting ⁽¹⁾

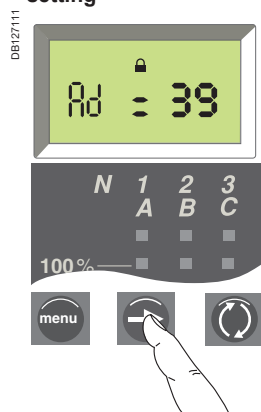

Press the button again to confirm and lock the new setting. The second digit stops flashing and a closed padlock is displayed.

Display next setting screen



Briefly press the button again to go on to the next parameter.

⁽¹⁾ The maximum address is 47. If you try to set a higher address, Trip System will set the address to the maximum address of 47.

Example 2 : Setting Output 1 (for ETV with optional M2C contacts)

The state of output 1 can be associated with the occurrence of a given trip event.



Access the Output 1 setting screen

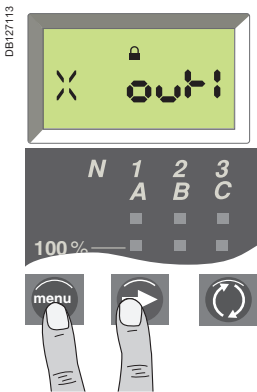

Simultaneously press the and the buttons for four seconds to access the Modbus address screen. Then press the button to access the output setting screen. The existing output setting is displayed (default setting is indicating that no trip event has been assigned to the output). A closed padlock icon indicates that the setting is locked.

Unlock and access the setting

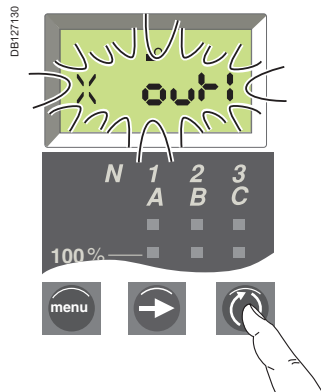

Press the button to open the padlock. The existing setting will flash, indicating it is ready to be modified

Modify the trip event assigned to Output 1

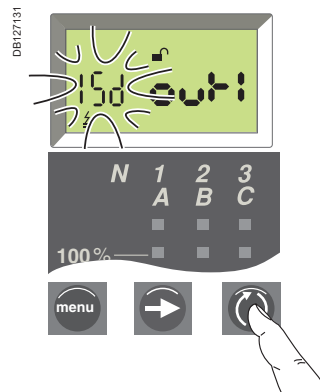

Press the button repeatedly until the desired trip event is displayed. You can scroll through all possible events in a loop (see list of possible events page 62).

Confirm and lock the trip event setting



Press the button to confirm and lock the new setting. The setting stops flashing and a closed padlock is displayed.

Modify the output state control mode

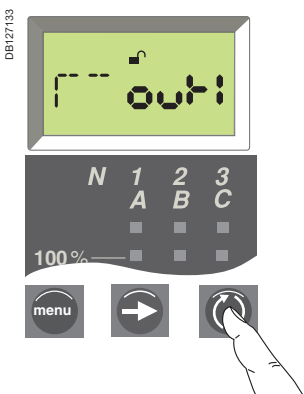

Press the button repeatedly until the desired output state control mode is displayed (see page 62). In normal mode, the output goes from "0" to "1" (without latching) on occurrence of the assigned event.

Confirm and lock the Output 1 state setting



Press on the button to confirm and lock the new setting. The setting stops flashing and a closed padlock is displayed.

Display next setting screen

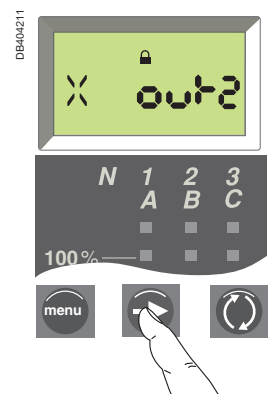

Press the button again to go to the screen for the next parameter.

Optional M2C contacts

ETV programmable outputs

Important:
The M2C contacts require an auxiliary power supply.

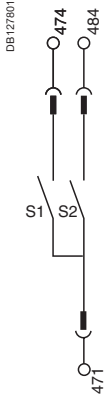

Wiring diagram for M2C contacts.

Possible functions

The ETV control unit can be equipped with up to two M2C contacts (S1 and S2) that can be used to activate:

- alarms to signal and identify tripping caused by long-time, short-time, instantaneous or ground-fault protection
- pre-alarms to warn of imminent tripping by ground-fault (ETV6G) or long-time protection.

Contact operation

The contacts can be set to change the state of ETV outputs Out1 and/or Out2 from 0 to 1 when certain events occur:

- trip events, i.e. when the control unit is tripped by:
 - long-time protection I_r
 - short-time instantaneous protection I_{sd} or I_i
 - ground-fault protection I_g (ETV6G only)
- pre-alarm events, i.e. when the current reaches 90 % of the following trip thresholds:
 - long-time protection setting I_r
 - ground-fault protection pickup I_g (ETV6G only).

For details on how to assign different events to the contacts, see "Output settings" on page 62 or the example on page 65.

Latching settings

When the output state setting is in "Normal mode" (see page 62), the contacts are non-latching, i.e. the contact remains activated (state = 1) only as long as the event that caused the change of state remains present.

Two other output state settings are available (forced to 1 or 0) for testing needs (see page 62).

Time delays

- Pickup: when the current exceeds the selected tripping or pre-alarm pickup threshold, the output state changes from 0 to 1 after a fixed time delay of 0.1 second.
- Dropout: when the circuit is opened by the circuit breaker or when the current falls below the pre-alarm dropout threshold (see page 39), the output state returns to 0 after a non-adjustable time delay of 0.1 second.

Contact operating diagrams

Contact operating diagram for long-time, short-time, instantaneous and ground-fault protection trip alarms

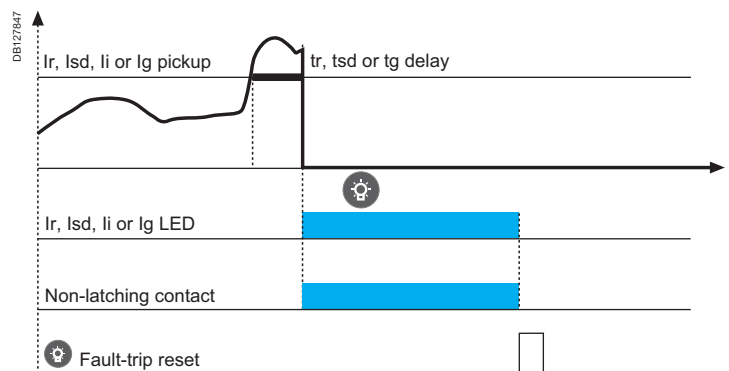

Contact operating diagram for I_r and I_g pre-alarms

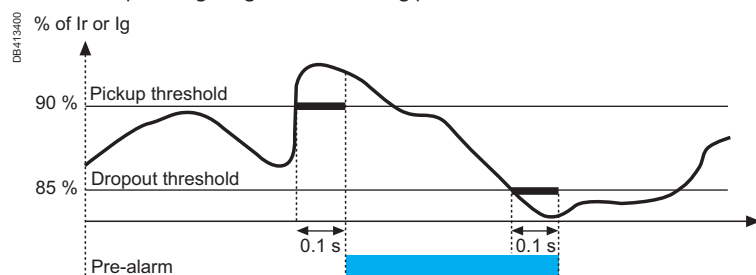

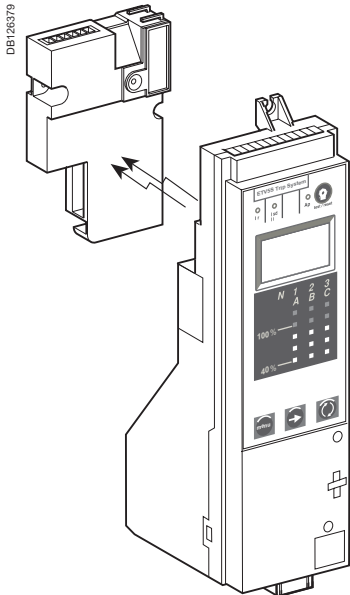

The communication option consists of an independent module that fits behind the trip system control unit.

Communication option

The communication option uses a Modbus communication protocol to remotely access the following information and functions available in the Trip Sytem control unit:

- status indications
- controls
- measurements
- operating assistance.

It consists of an independent communication module installed behind the Trip Sytem control unit. This module receives and transmits information via the communication network. An infra-red link transmits data between the control unit and the communication module.

Modbus communication

Modbus bus

The Modbus RS 485 (RTU protocol) system is an open bus on which communicating Modbus devices (EasyPact with Modbus EcoCOM) are installed. All types of PLCs and computers may be connected to the bus.

Modbus communication parameters

For a EasyPact circuit breaker equipped with a Trip Sytem control unit, the Modbus address, baud rate and parity are set using the keypad on the control unit.

The Modbus communication system is divided into four managers that secure data exchange with the supervision system and the circuit-breaker actuators.

The manager addresses are automatically derived from the circuit-breaker address @xx entered via the Trip Sytem control unit (the default address is 47).

Modbus addresses

@xx	Circuit-breaker manager	(1 to 47)
@xx + 50	Chassis manager	(51 to 97)
@xx + 200	Measurement managers	(201 to 247)
@xx + 100	Protection manager	(101 to 147)

Number of devices

The maximum number of devices that may be connected to the Modbus bus depends on the type of device (EasyPact with Modbus EcoCOM, the baud rate (19200 bauds is recommended), the volume of data exchanged and the desired response time. The RS 485 physical layer offers up to 32 connection points on the bus (1 master, 31 slaves).

Each protection devices uses 1 or 2 connection points:

- a fixed device requires only one connection point (communication module on the device)
- A drawout or withdrawable device uses two connection points (communication modules on the device and on the chassis).

The number of devices must never exceed 31 fixed devices or 15 drawout/withdrawable devices.

Bus length

The maximum recommended length for the Modbus bus is 1200 m.

Bus power source

A 24 V DC power supply is required (less than 20 % ripple, insulation class II).

Data and functions available via the communication option

EasyPact circuit breakers equipped with Trip System control units and the Communication option can be integrated in a Modbus communication environment. In this case the following information and functions are available remotely.

	ETV
Status indications	
ON/OFF	■
Spring charged CH	■
Ready to close PF	■
Fault-trip SDE	■
Connected/disconnected/test position (via CE/CD/CT contacts of optional chassis communication module)	■
Measurements	
Current	
Instantaneous currents I1, I2, I3, IN, Ig, IΔN	■
Current maximeters: I1max, I2max, I3max, INmax, Igmax, IΔNmax	■
Average current Iavg	■
Current unbalance Iunbal	■
Demand current	
Demand currents I1, I2, I3, IN	■
Demand current maximeters (peak demands) I1 max, I2 max, I3 max, IN max	■
Voltage	
Phase-to-phase voltages V12, V23, V31 (3-wire and 4-wire systems)	■
Phase-to-neutral voltages V1N, V2N, V3N (4-wire systems) ⁽¹⁾	■
Average voltage Vavg	■
Voltage unbalance Vunbal	■
Power	
Instantaneous power P, Q, S	■
Demand power P, S	■
Demand power maximeters Pmax	■
Instantaneous power factor PF	■
Energy	
Total Energy Ep	■
Total Energy Eq, Es	■
Operating assistance	
Setting of the control-unit date and time	■
Functional unit (IMU) name	■
Power sign	■
Interval for the demand-current calculation window	■
Interval for the demand power calculation window	■
Battery-charge indication	■
Trip histories	■
Operation counter	■
Assignment and setup of programmable contacts (M2c)	■
Protection	
Circuit-breaker rated current	■
Type of neutral protection	■
Long-time I ² t protection settings	■
Short-time protection settings	■
Instantaneous-protection settings	■
Ground-fault protection settings	■ 6.0 E
Earth-leakage protection settings	■

⁽¹⁾ Important: for 3-pole circuit breakers used on 4-wire systems (3ph + N), terminal VN on the Trip System control unit must always be connected to the neutral. If this is not done, the phase-to-neutral voltage measurements can be erroneous.

Long-time and instantaneous protection (ET/ETA/ETV 2I Trip System)

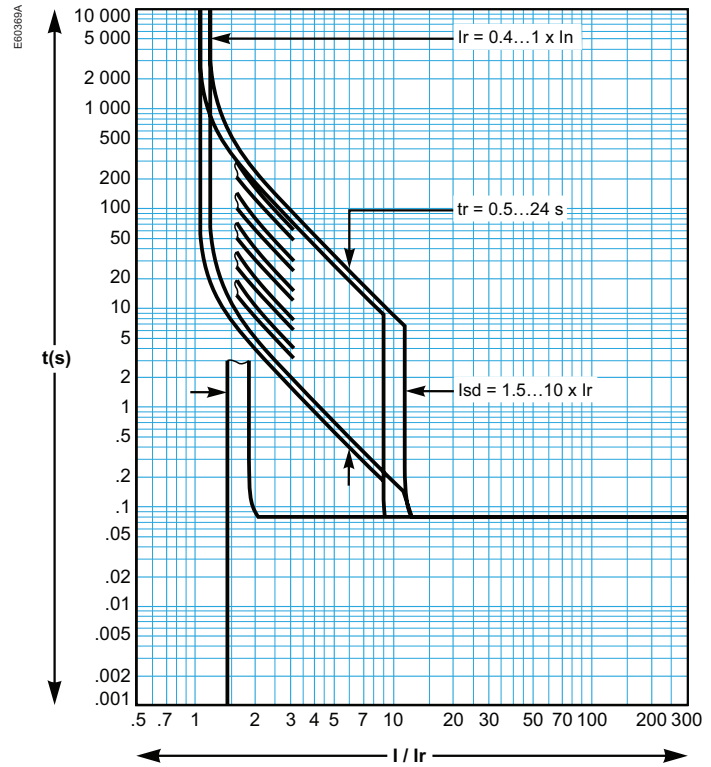

Long-time, short-time and instantaneous protection (ET/ETA/ETV 5S Trip System)

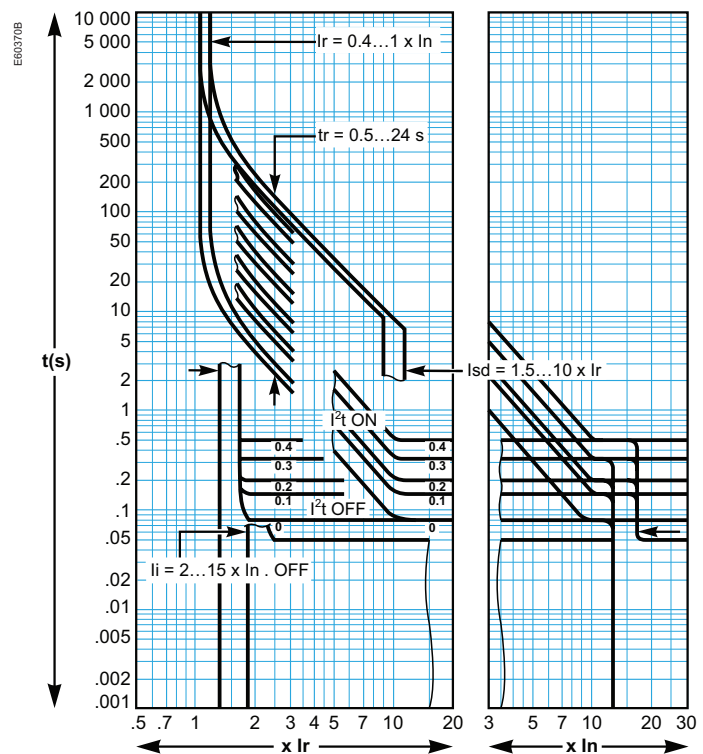

Long-time, short-time and instantaneous protection (ET/ETA/ETV 6G Trip System)

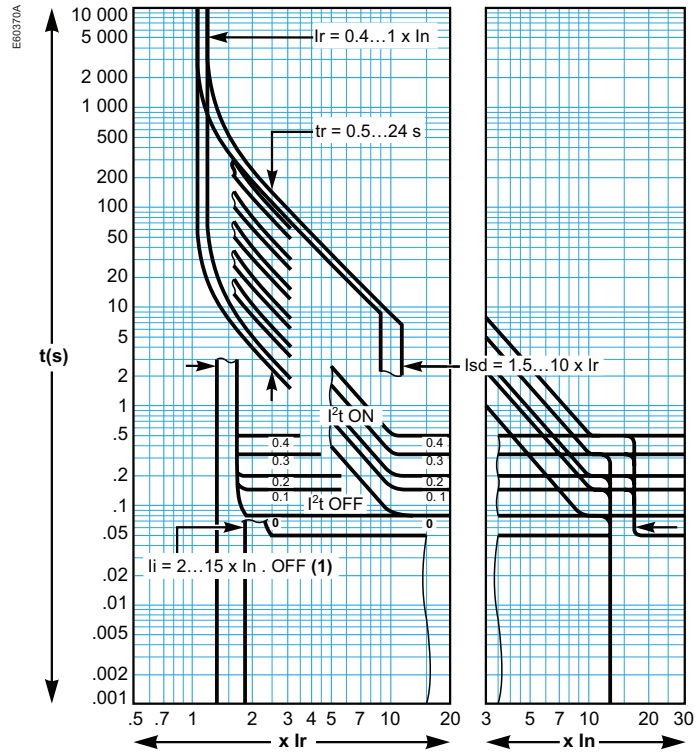

Ground-fault protection (ET/ETA/ETV 6G Trip System)

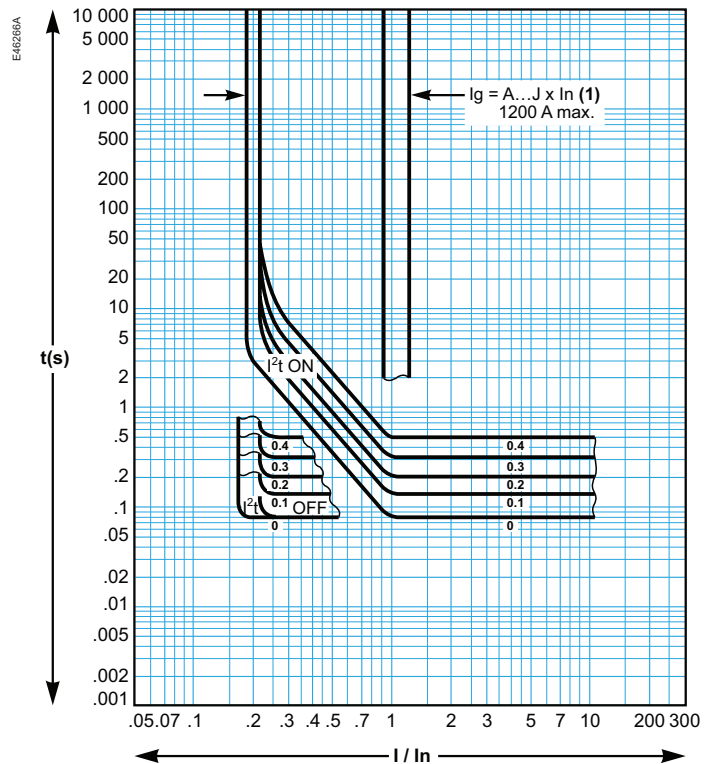

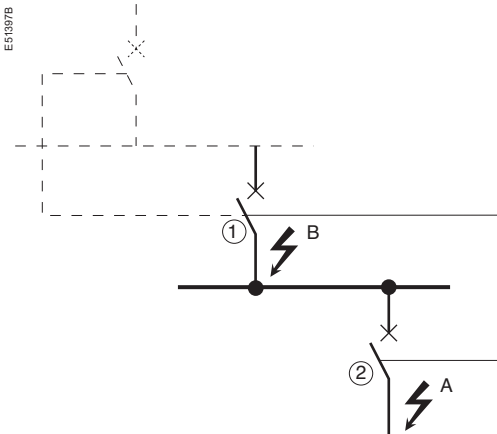

Operating principle

- A fault occurs at point A.
Downstream device no. 2 clears the fault and sends a signal to upstream device no. 1, which maintains the short-time tripping delay t_{sd} or the ground-fault tripping delay t_g to which it is set.
- A fault occurs at point B.
Upstream device no. 1 detects the fault. In the absence of a signal from a downstream device, the set time delay is not taken into account and the device trips according to the zero setting. If it is connected to a device further upstream, it sends a signal to that device, which delays tripping according to its t_{sd} or t_g setting.

Note :

On device no. 1, the t_{sd} and t_g tripping delays must not be set to zero because this would make discrimination impossible.

Connections between control units

A logic signal (0 or 5 volts) can be used for zone selective interlocking between the upstream and downstream circuit breakers.

- ETA 5S, 6G
- ETV 5S, 6G

An interface is available for connection to previous generations of trip units.

Caution.

If the protection function is not used on circuit breakers equipped for ZSI protection, a jumper must be installed to short terminals Z3, Z4 and Z5.

If the jumper is not installed, the short-time and ground-fault tripping delays are set to zero, whatever the position of the adjustment dial.

Terminals Z1 to Z5 correspond to the identical indications on the circuit-breaker terminal blocks.

Wiring

- maximum impedance: 2.7 Ω / 300 m
- capacity of connectors: 0.4 to 2.5 mm²
- wires: single or multicore
- maximum length: 3000 metres
- limits to device interconnection:
 - the common ZSI - OUT (Z1) and the output ZSI - OUT (Z2) can be connected to a maximum of 10 inputs;
 - a maximum of 100 devices may be connected to the common ZSI - IN (Z3) and to an input ZSI - IN CR (Z4) or GF (Z5).

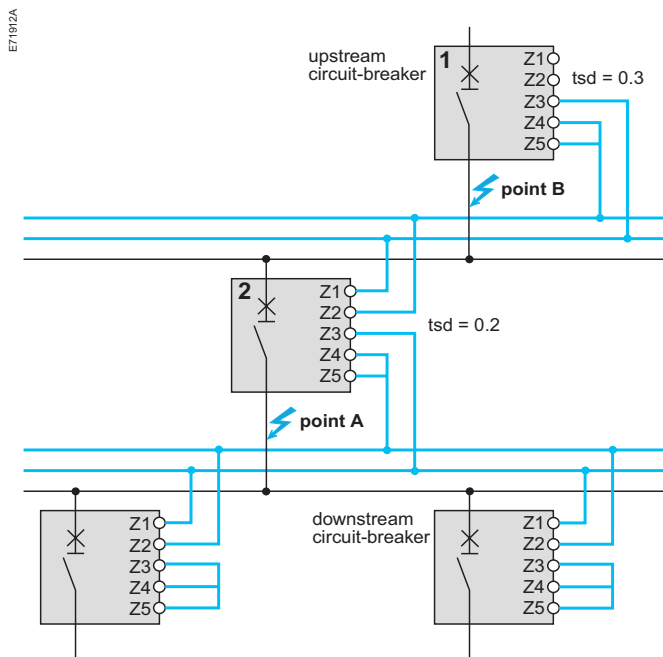

Test

The portable test kit may be used to check the wiring and operation of the zone selective interlocking between a number of circuit breakers.

For information on connecting an external power supply, see the electrical diagrams in the circuit-breaker catalogue.

PB101026-32A



External power supply.

- The display operates without an external power supply. The digital display goes off if the current drops below $0.2 \times I_n$ (I_n = rated current). An optional 24 V DC external power supply may be used to maintain the display of currents even when the current drops below $0.2 \times I_n$.

- Display back-lighting is disabled in the following situations:
 - current less than $1 \times I_n$ on one phase;
 - current less than $0.4 \times I_n$ on two phases;
 - current less than $0.2 \times I_n$ on three phases.

- The maximeter does not operate for currents under $0.2 \times I_n$.

- The display back-lighting and the maximeter may be maintained, whatever the current, by adding a 24 V DC external power supply. Even if an external power supply is installed, the long-time, short-time, instantaneous and earth protection functions will not use it.

External power supply characteristics

- Input voltage:
 - 11 0/130, 200/240, 380/415 V AC (+10 % -15 %)
 - 24/30, 48/60, 100/125 V DC (+20 % -20 %).
- Output voltage: 24 V DC ± 5 %, 1 A.
- Ripple < 1 %.
- Dielectric withstand : 3.5 kV rms between input/output, for 1 minute.
- Overvoltage category: as per IEC 60947-1 cat. 4.

Thermal memory

The thermal memory is a means to simulate temperature rise and cooling caused by changes in the flow of current in the conductors.

These changes may be caused by:

1. repetitive motor starting;
2. loads fluctuating near the protection settings;
3. repeated circuit-breaker closing on a fault.

Control units without a thermal memory (contrary to bimetal strip thermal protection) do not react to the above types of overloads because they do not last long enough to cause tripping.

However, each overload produces a temperature rise and the cumulative effect can lead to dangerous overheating.

Trip System with a thermal memory record the temperature rise caused by each overload. Even very short overloads produce a temperature rise that is stored in the memory. This information stored in the thermal memory reduces the tripping time.

ET/ETA/ETV Trip System and thermal memory

All ET/ETA/ETV Trip System are equipped as standard with a thermal memory.

1. for all protection functions, prior to tripping, the temperature-rise and cooling time constants are equal and depend on the tripping delay in question:
 - a. if the tripping delay is short, the time constant is low;
 - b. if the tripping delay is long, the time constant is high.

2. for long-time protection, following tripping, the cooling curve is simulated by the ET/ETA/ETV Trip System.

Closing of the circuit breaker prior to the end of the time constant (approximately 20 minutes) reduces the tripping time indicated in the tripping curves.

Short-time protection and intermittent faults

For the short-time protection function, intermittent currents that do not provoke tripping are stored in the ET/ETA/ETV Trip System memory.

This information is equivalent to the long-time thermal memory and reduces the tripping delay for the short-time protection.

Following a trip, the short-time tsd tripping delay is reduced to the value of the minimum setting for 20 seconds.

Ground-fault protection and intermittent faults

The ground-fault protection implements the same function as the short-time protection.

Calculating demand values (ETV Trip System)

The ETV trip unit calculates and displays:

- the demand values of phase and neutral currents,
- the demand value of the total active power.

The maximum (peak) demand current and power values are stored in the memory. All demand values are updated once every minute.

Definition

The demand value of a quantity is its average value over a given period of time. In electrical power systems, it is used especially for the current and power. The demand value should not be confused with the instantaneous value or the average (or mean) value, which often refers to the average (or mean) of the instantaneous values of the 3 phases.

Calculation interval

The time interval (or window) over which the average is calculated can be of 3 types:

- fixed window
- sliding window.

Fixed window

At the end of a fixed metering window:

- the demand value over the window is calculated and updated
- the new demand value is initialised over a new window, **starting from the end of the last window**.

Sliding window

At the end of a sliding window:

- the demand value over the window is calculated and updated
- the new demand value is initialised over a new window, **starting from a given time after the start of the last window** (always less than the duration of the window).

The sliding window method is used by ETV control units.

- The duration of the sliding window can be set separately for current and power demand from 5 to 60 minutes in 1 minute steps (see Measurement settings on page 62). The default setting is 15 minutes.
- The time shift between intervals is equal to 1 minute.

Calculation method

Quadratic demand (thermal image)

The quadratic demand calculation model represents the conductor heat rise (thermal image).

The heat rise created by the current $I(t)$ over the time interval T is identical to that created by a constant current I_{th} over the same interval. This current I_{th} represents the thermal effect of the current $I(t)$ over the interval T .

Calculation of the demand value according to the thermal model must be always performed on a sliding window.

Note: The thermal demand value is similar to an rms value.

ETV control units use the quadratic model to calculate both demand current and demand power.

Peak demand values

The ETV trip unit calculates:

- the maximum (peak) demand values of phase and neutral currents since the last reset
- the maximum (peak) demand values of total active power since the last reset.

The peak demand values can be accessed and/or reset in the following ways:

- peak demand current: via the ETV control unit (see page 57) or the Communication option (see page 68)
- peak demand power: via the Communication option (see page 68).

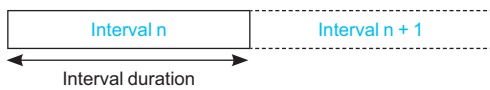

Fixed window

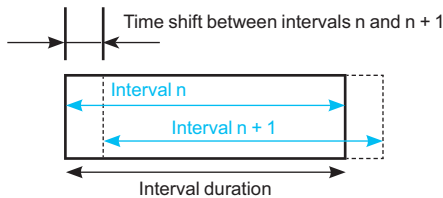

Sliding window

MVS06-16(C)

DB119377

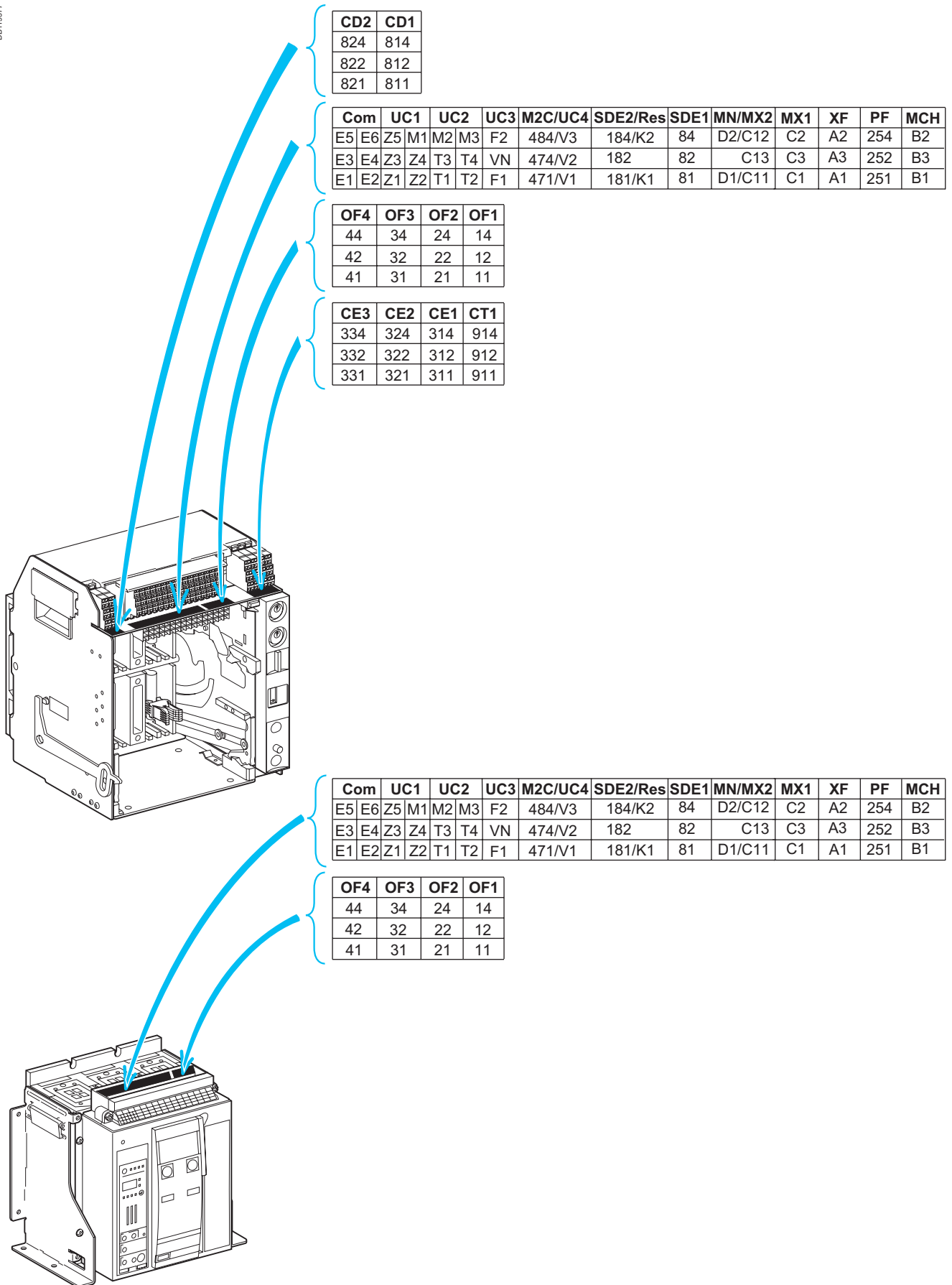

MVS08-40(N/H/T)

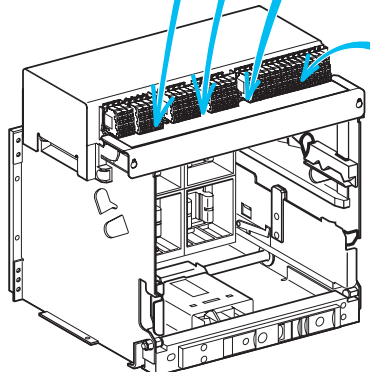

CD3 CD2 CD1

834	824	814
832	822	812
831	821	811

Com	UC1	UC2	UC3	UC4	M2C/M6C	SDE2/Res _n	SDE1	CE3	CE2	CE1			
E5	E6	Z5	M1	M2	M3	F2 +	V3	484/Q3	184/K2	84	334	324	314
E3	E4	Z3	Z4	T3	T4	VN	V2	474/Q2	182	82	332	322	312
E1	E2	Z1	Z2	T1	T2	F1 -	V1	471/Q1	181/K1	81	331	321	311

MN/MX2	MX1	XF	PF	MCH
D2/C12	C2	A2	254	B2
/C13	C3	A3	252	B3
D1/C11	C1	A1	251	B1

OF14	OF13	OF12	OF11	OF4	OF3	OF2	OF1	CT3	CT2	CT1
144	134	124	114	44	34	24	14	934	924	914
142	132	122	112	42	32	22	12	932	922	912
141	131	121	111	41	31	21	11	931	921	911

Indication contacts

OF14	ON/OFF indication	OF 4	ON/OFF indication
OF13	contacts	OF 3	contacts
OF12	contacts	OF 2	contacts
OF11	(optional)	OF 1	(standard)

Chassis contacts

CD3	Disconnected position	CE3	Connected position	CT3	Test position
CD2	contacts	CE2	contacts	CT2	contacts
CD1		CE1		CT1	

Draw-out Air Circuit Breaker

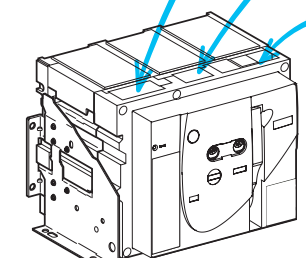

Com	UC1	UC2	UC3	UC4	M2C/M6C	SDE2/Res _n	SDE1	CE3	CE2	CE1			
E5	E6	Z5	M1	M2	M3	F2 +	V3	484/Q3	184/K2	84	334	324	314
E3	E4	Z3	Z4	T3	T4	VN	V2	474/Q2	182	82	332	322	312
E1	E2	Z1	Z2	T1	T2	F1 -	V1	471/Q1	181/K1	81	331	321	311

MN/MX2	MX1	XF	PF	MCH
D2/C12	C2	A2	254	B2
/C13	C3	A3	252	B3
D1/C11	C1	A1	251	B1

OF14	OF13	OF12	OF11	OF4	OF3	OF2	OF1
144	134	124	114	44	34	24	14
142	132	122	112	42	32	22	12
141	131	121	111	41	31	21	11

Fixed Air Circuit Breaker

The diagram is shown with circuits de-energised, all devices open, connected and charged and relays in normal position.

Power

ET/ETA/ETV trip system

Remote operation

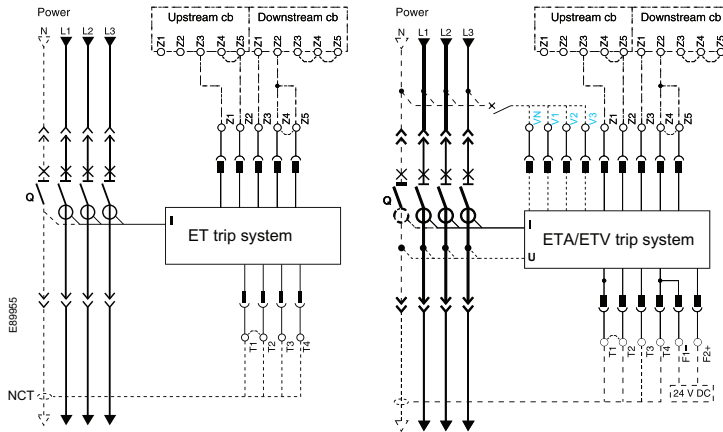

Note: V1...VN Voltage connections are available in ETV trip system.

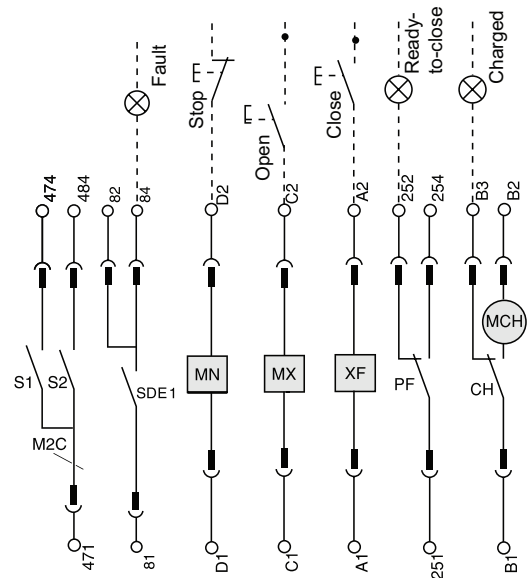

ET trip system

UC1	UC2
○ Z5	
○ Z3 ○ Z4	○ T3 ○ T4
○ Z1 ○ Z2	○ T1 ○ T2

EA/ETV trip system

Com	UC1	UC2	UC3	M2C
○ E5 ○ E6	○ Z5 ○ M1	○ M2 ○ M3	○ F2+	○ 484
○ E3 ○ E4	○ Z3 ○ Z4	○ T3 ○ T4	○ VN	○ 474
○ E1 ○ E2	○ Z1 ○ Z2	○ T1 ○ T2	○ F1-	○ 471

Remote operation

SDE	MN	MX	XF	PF	MCH
○ 84	○ D2	○ C2	○ A2	○ 254	○ B2
○ 82				○ 252	○ B3
○ 81	○ D1	○ C1	○ A1	○ 251	○ B1

ET/ETA/ETV trip system

UC1 :
Z1-Z5 zone selective interlocking
Z1=ZSI OUT SOURCE
Z2=ZSI OUT ; Z3 = ZSI IN SOURCE
Z4 =ZSI IN ST (short time)
Z5 =ZSI IN GF (earth fault)
COM :E1-E6 communication

UC2 :
T1, T2, T3, T4=external neutral
MC2 : 2 programmable contacts (external relay)
ext. 24 V DC power supply required.
UC3 :
F2+, F1-: external 24 V DC power supply
VN: external voltage connector (must be connected to the neutral CT with a 3P circuit breaker equipped with ETV trip system)

Remote operation

SDE: Fault-trip indication contact (supplied as standard)
MN: Undervoltage release
MX: Shunt release (standard for Electrical breaker)
XF: Closing release (standard for Electrical breaker)
PF: "Ready to close"contact
MCH: Gear motor (standard for Electrical breaker)

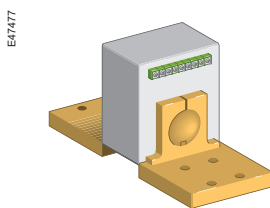

External sensor(CT)

External sensors (Neutral CT)

External sensor for earth-fault protection

The sensors, used with the 3P circuit breakers, are installed on the neutral conductor for:

- residual type earth-fault protection (with ET/ETA/ETV 6G Trip System)

The rating of the sensor (CT) must be compatible with the rating of the circuit breaker:

- MVS06 to MVS 16: CT 400/1600; UV number: 33576
- MVS08 to MVS 20: CT 400/2000; UV number: 34035
- MVS25 to MVS 40: CT 1000/4000; UV number: 34036

MVS06-16(C)

Indication contacts

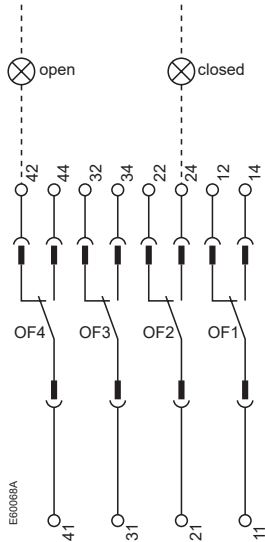

Chassis contacts

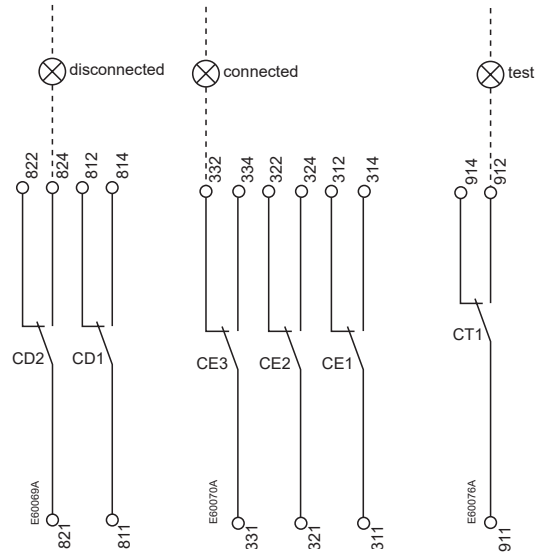

Indication contacts

OF4	OF3	OF2	OF1
44	34	24	14
42	32	22	12
41	31	21	11

Contacts chassis

CD2	CD1	CE3	CE2	CE1	CT1
824	814	334	324	314	914
822	812	332	322	312	912
821	811	331	321	311	911

Indication contacts

OF4 / OF3 / OF2 / OF1: ON/OFF indication contacts

Chassis contacts

CD2-CD1: Disconnected-position
 CE3-CE2-CE1: Connected-position
 CT1: Test-position contacts

(*) 440/480 V AC gear motor for charging
 (380 V motor + additional resistor)

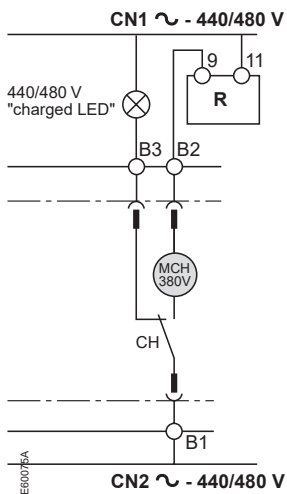

Key:

- Drawout device only
- SDE1, OF1, OF2, OF3, OF4 supplied as standard
- Interconnected connections (only one wire per connection point)

MVS08-40(N/H/T)

Indication contacts

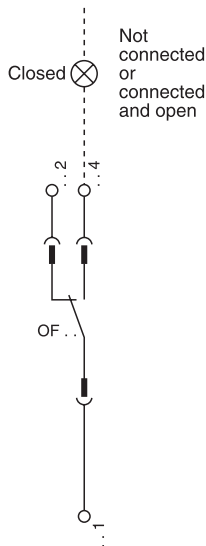
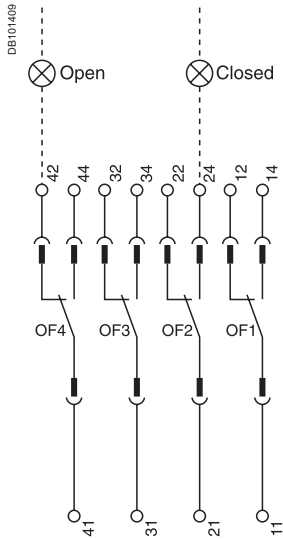

Chassis contacts

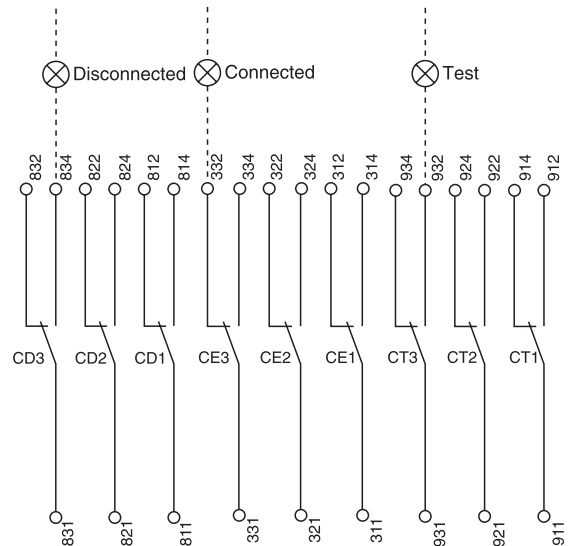

Indication contacts

OF4	OF3	OF2	OF1
44	34	24	14
42	32	22	12
41	31	21	11

standard

OF14	OF13	OF12	OF11
144	134	124	114
142	132	122	112
141	131	121	111

optional

Chassis contacts

CD3	CD2	CD1	CE3	CE2	CE1	CT3	CT2	CT1
834	824	814	334	324	314	934	924	914
832	822	812	332	322	312	932	922	912
831	821	811	331	321	311	931	921	911

optional

Indication contacts

OF4	ON/OFF
OF3	indication
OF2	contacts
OF1	(standard)

OF 14	ON/OFF
OF 13	indication
OF 12	contacts
OF 11	(optional)

Chassis contacts

CD3	Disconnected	CE3	Connected	CT3	Test-position
CD2	position	CE2	position	CT2	contacts
CD1	contacts	CE1	contacts	CT1	

Key:

Draw out device only

SDE, OF1, OF2, OF3, OF4 supplied as standard

Interconnected connections (only one wire per connection point)

MVS06-16 (C)

The ON/OFF indication contacts signal the status of the device main contacts.

Circuit breaker

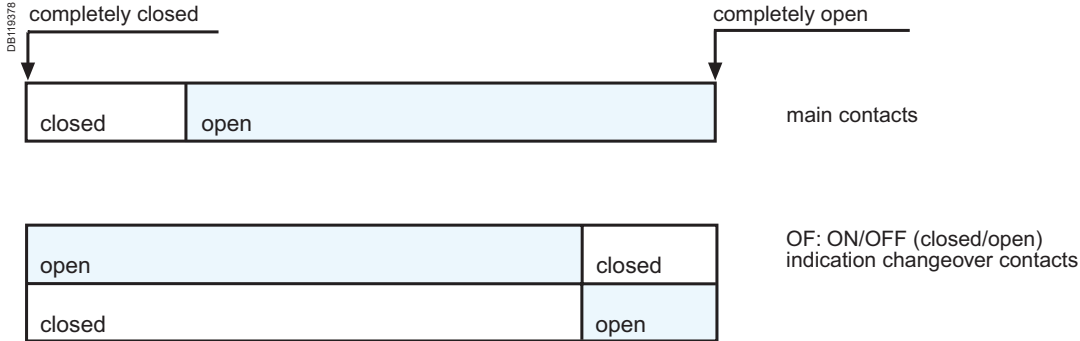

The carriage switches indicate the "connected", "test" and "disconnected" positions.

Chassis

For information on the separation distance of the main circuits in the "test" and "disconnected" positions, see page 16.

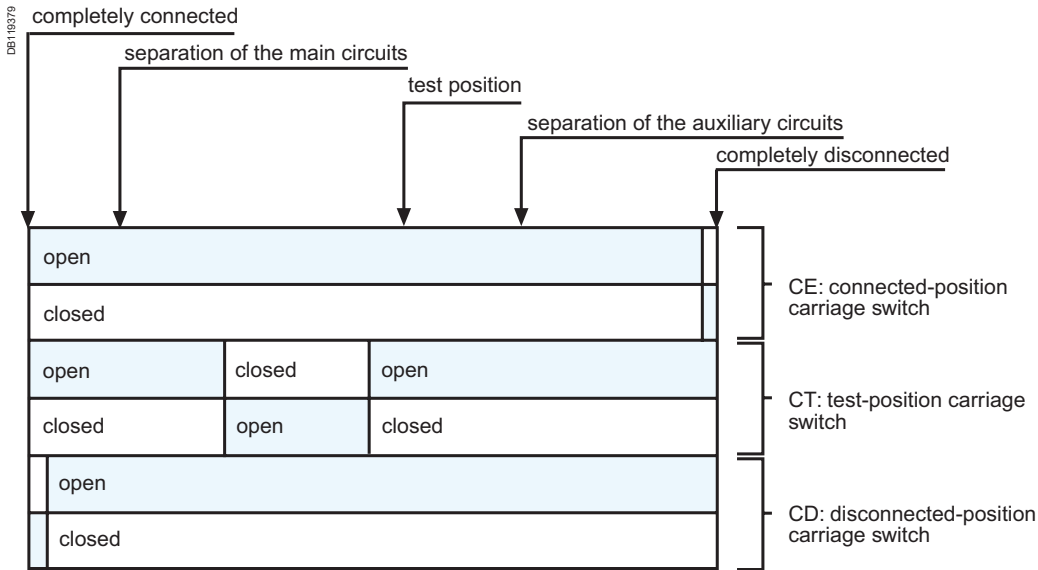

MVS08-40(N/H/T)

The ON/OFF indication contacts signal the status of the device main contacts.

Circuit breaker

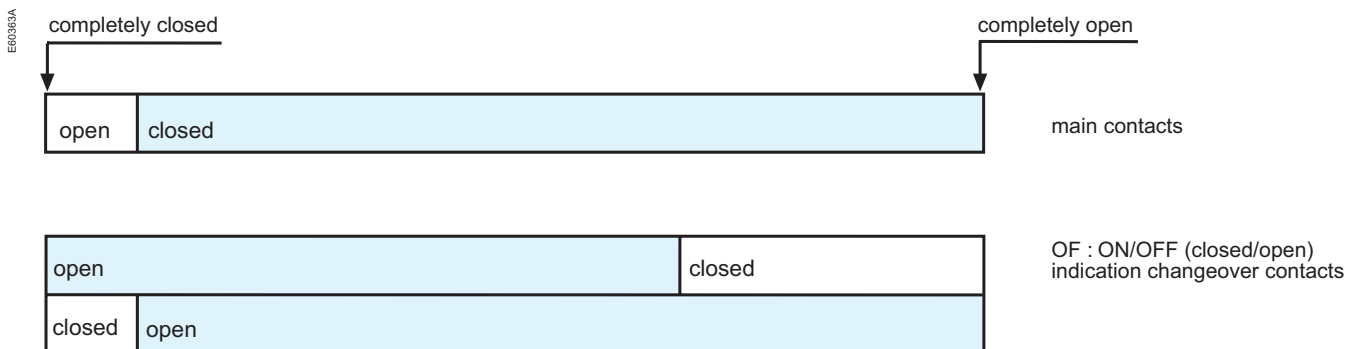

The carriage switches indicate the "connected", "test" and "disconnected" positions.

Chassis

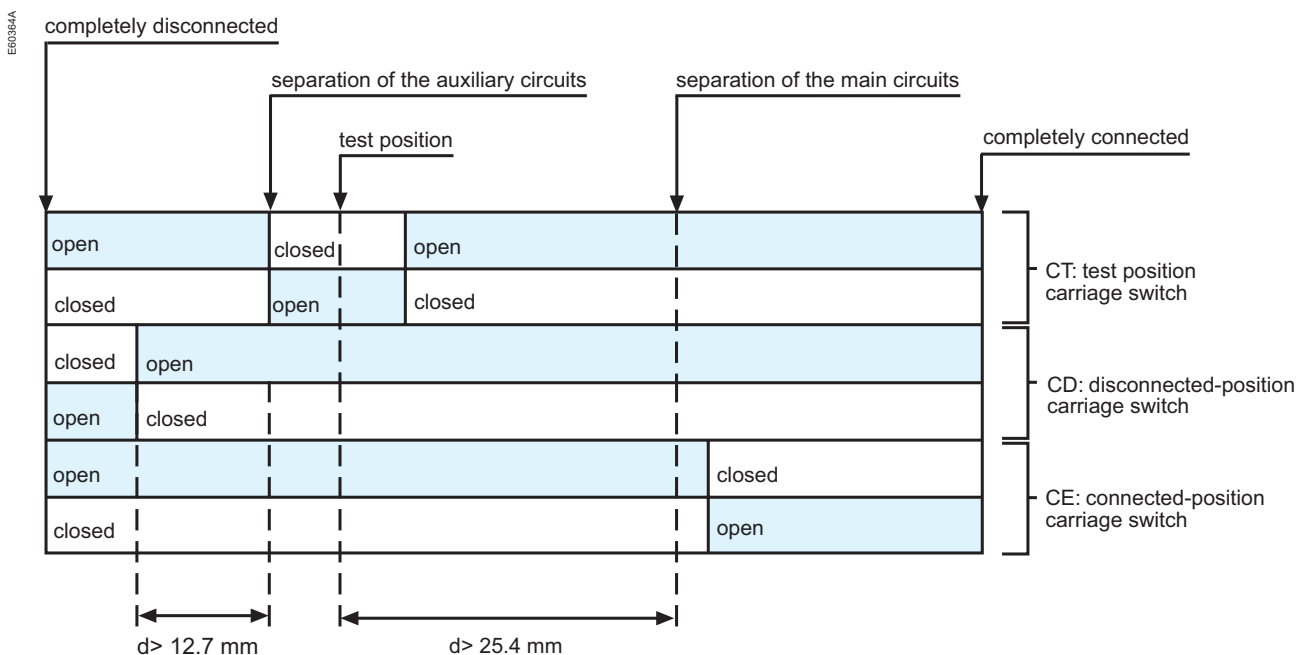

MVS06-16(C)

"Springs charged" limit switch contact (CH)

- Contact included with MCH gear motor, one CH contact per device.
- The contact indicates the "charged" status of the operating mechanism (springs charged).
- Changeover contact
- Breaking capacity 50/60 Hz for AC power (AC12 / DC12 as per IEC 60947-5-1):

V AC	240	10A(rms)
	380	6 A (rms)
	480	6 A (rms)
	690	3 A (rms)
V DC	24/48	3 A
	125	0.5 A
	250	0.25 A

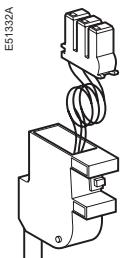

"Ready to close" contact (PF)

- One optional PF contact per device
- The contact indicates that the device may be closed because all the following are valid:
 - circuit breaker is open
 - spring mechanism is charged
 - a maintained closing order is not present
 - a maintained opening order is not present.
- Changeover contact
- Breaking capacity at $\cos \varphi = 0.3$ (AC12 / DC12 as per IEC 60947-5-1)
 - standard, minimum current 10 mA / 24 V

V AC	240/380	5 A (rms)
------	---------	-----------

MVS08-40(N/H/T)

E51331A

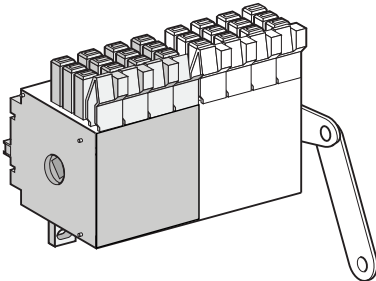

ON/OFF indication contacts(OF)

- | | | |
|---|--|--|
| <ol style="list-style-type: none"> 1. standard equipment:
4 OF per device. | <ol style="list-style-type: none"> 1. OF contacts indicate the position of main contacts 2. they trip when the minimum isolation distance between the main contacts is reached | <ol style="list-style-type: none"> 1. 4 changeover contacts 2. rated current: 10 A 3. breaking capacity 50/60 Hz for AC power (AC12 as per IEC60947-5-1): <ol style="list-style-type: none"> a. 240/380 V: 10 A (rms) b. 480 V: 10 A (rms) 4. breaking capacity for DC power (DC12 as per IEC60947-5-1):250 V:3A. |
|---|--|--|

Optional ON/OFF indication contacts(OF)

- | | | |
|---|--|---|
| <ol style="list-style-type: none"> 1. optional equipment, one block of 4 OF contacts per device 2. connection cables not included, see below: one block of 4 OF contacts:47887 3. connection cables: <ol style="list-style-type: none"> a. for fixed device:47074 b. for drawout device:47849 | <ol style="list-style-type: none"> 1. OF contacts indicate the position of the main contacts 2. they trip when the minimum isolation distance between the main contacts is reached | <ol style="list-style-type: none"> 1. changeover contacts 2. rated current: 6 A 3. breaking capacity 50/60 Hz for AC power (AC12 as per IEC60947-5-1): <ol style="list-style-type: none"> a. 240/380 V: 6A (rms) b. 480 V: 6 A (rms) 4. breaking capacity for DC power (DC12 IEC60947-5-1):250 V:3A. |
|---|--|---|

"Fault-trip" indication contact(SDE)

- | | | |
|---|--|--|
| <ol style="list-style-type: none"> 1. standard equipment on circuit breakers, one SDE contact per device 2. not available for switch- disconnecter versions | <ol style="list-style-type: none"> 1. the contact provides a remote indication of device opening due to an electrical fault | <ol style="list-style-type: none"> 1. changeover contacts 2. rated current: 5 A 3. breaking capacity 50/60 Hz for AC power (AC12 as per IEC60947-5-1): <ol style="list-style-type: none"> a. 240/380V:5A(rms) b. 480 V: 5 A (rms) 4. breaking capacity for DC power (DC12 as per IEC60947-5-1): <ol style="list-style-type: none"> a. 48 V: 3 A b. 125 V: 0.3 A c. 250 V: 0.15 A. |
|---|--|--|

E51332A

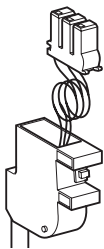

"Ready to close" contact(PF)

- | | | |
|--|---|--|
| <ol style="list-style-type: none"> 1. optional equipment, one PF contact per device 2. connections cables not included one PF Contact :47080 3. connection cables: <ol style="list-style-type: none"> a. for fixed device:47074 b. for drawout device: 47849 | <ol style="list-style-type: none"> 1. the contact indicates that the device may be closed because all the following are valid: <ol style="list-style-type: none"> a. circuit breaker is open b. spring mechanism is charged c. a maintained closing order is not present d. a maintained opening order is not present | <ol style="list-style-type: none"> 1. change over contact 2. rated current: 5 A 3. breaking capacity 50/60 Hz for AC power (AC12 as per IEC60947-5-1): <ol style="list-style-type: none"> a. 240/380 V: 5 A (rms) b. 480 V: 5 A (rms) 4. breaking capacity for DC power (DC12 as per IEC60947-5-1): <ol style="list-style-type: none"> a. 48 V: 3 A b. 125 V: 0.3 A c. 250 V: 0.15 A. |
|--|---|--|

"Springs charged" limit switch contact (CH)

- | | | |
|--|--|--|
| <ol style="list-style-type: none"> 1. standard equipment, one CH contact per device | <ol style="list-style-type: none"> 1. the contact indicates the "charged" status of the operating mechanism (springs charged) | <ol style="list-style-type: none"> 1. changeover contact 2. rated current: 10 A 3. breaking capacity 50/60 Hz for AC power (AC12 as per 60947-5-1): <ol style="list-style-type: none"> a. 240 V: 10 A (rms) |
|--|--|--|

MVS06-16(C)

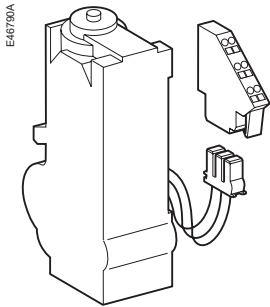

Gear motor (MCH)

- Optional accessory, one MCH gear motor per device
- Power supply:
 - V AC 50/60 Hz:
 - 100/130 V AC
 - 200/240 V AC
 - 380/415 V AC
 - V DC:
 - 24/30 V DC
 - 48/60 V DC
 - 100/125 V DC
 - 200/250 V DC
- The gear motor automatically charges the spring mechanism.
- Operating threshold: 0.85 to 1.1 Un
- Consumption: 180 VA or W
- Inrush current: 2 to 3 In for 0.1 second
- Charging time: 3 seconds max.
- Operating rate: maximum 3 cycles per minute

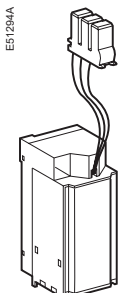

Opening releases MX closing release XF

- Optional accessory, 1 or 2 MX releases per device, 1 XF per device
- The function (MX or XF) is determined by where the coil is installed
- Power supply:
 - V AC 50/60 Hz:
 - 24 V AC
 - 48 V AC
 - 100/130 V AC
 - 200/250 V AC
 - 380/480 V AC
 - V DC:
 - 24/30 V DC
 - 48/60 V DC
 - 100/130 V DC
 - 200/250 V DC
- The MX release instantaneously opens the circuit breaker when energised
- The XF release instantaneously closes the circuit breaker when energised, if the device is "ready to close".
- Operating threshold:
 - XF: 0.85 to 1.1 Un
 - MX: 0.7 to 1.1 Un
- Consumption:
 - pick-up: 200 VA or W (80 ms)
 - hold: 4.5 VA or W
- Circuit-breaker response time at Un:
 - XF: 55 ms ± 10
 - MX: 50 ms ± 10.

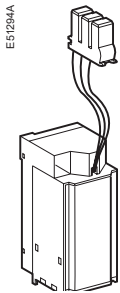

Instantaneous undervoltage releases (MN)

- Optional accessory, 1 MN per device
- Not compatible with the MX2 opening release
- Power supply:
 - V AC 50/60 Hz:
 - 24 V AC
 - 48 V AC
 - 100 / 130 V AC
 - 200 / 250 V AC
 - 380 / 480 V AC
 - V DC:
 - 24 / 30 V DC
 - 48 / 60 V DC
 - 100 / 130 V DC
 - 200 / 250 V DC
- The MN release instantaneously opens the circuit breaker when its supply voltage drops.
- Device response time: 90 ms ± 5
- Operating threshold:
 - opening: 0.35 to 0.7 x Un
 - closing: 0.85 x Un
- Consumption:
 - pick-up (80 ms): 200 VA
 - hold: 4.5 VA.

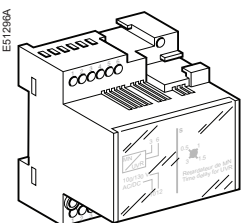

Delay unit for MN releases

- Optional accessory, 1 MNR with delay unit per device.
- Delay-unit (must be ordered in addition to the MN):
 - 48/60 V AC 50/60 Hz / DC
 - 100/130 V AC 50/60 Hz / DC
 - 200/250 V AC 50/60 Hz / DC
 - 380/480 V AC 50/60 Hz / DC.
- The unit delays operation of the MN release to eliminate circuit-breaker nuisance tripping during short voltage dips
- The unit is wired in series with the MN and must be installed outside the circuit breaker.
- Device response time: 0.5, 1, 1.5, 3 seconds
- Operating threshold:
 - opening: 0.35 to 0.7 x Un
 - closing: 0.85 x Un
- Consumption:
 - pick-up (80 ms): 200 VA
 - hold: 4.5 VA.

MVS08-40(N/H/T)

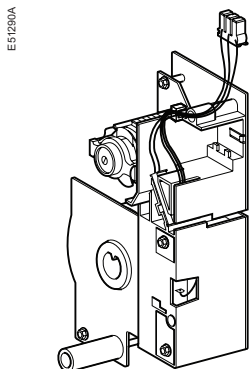

E51290A

Gear motor (MCH)

- optional equipment, one MCH gear motor per device
 - connection cables not included, see below:
 - 24/30V DC : 47888
 - 48/60V DC : 47889
 - 100/130V DC: 47890
 - 200/250V DC: 47891
 - 100/130V AC: 47893
 - 200/240V AC: 47894
 - 380/415V AC: 47896
 - connection cables:
 - for fixed device:4707
 - for drawout device:47849
- the gear motor automatically charges and recharges the spring mechanism
- charging time: 4 seconds max.
 - consumption:
 - 180 VA AC
 - 180 W DC
 - in rush current: 2 to 3 In for 0.1 second
 - operating rate: maximum 3 cycles per minute.

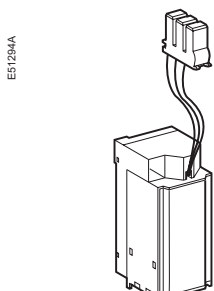

E51294A

Opening release(MX)

- optional equipment, 1 MX per device.
 - connections cables not included, see below.
 - 24/30 V AC/DC: 33659
 - 48/60 V AC/DC: 33660
 - 100/130 V AC/DC: 33661
 - 200/250 V AC/DC: 33662
 - 380/480 V AC/DC: 33664
 - connection cables:
 - for fixed device: 47074
 - for drawout device: 47849
- the MX release instantaneously opens the circuit breaker when energised
 - the coil to be fixed at the defined location only
- device response time: 50ms ±10
 - operating threshold: 0.7to1.1xUn
 - the supply can be maintained
 - consumption:
 - pick-up: 200VA/200W
 - hold: 4.5 VA/4.5W.

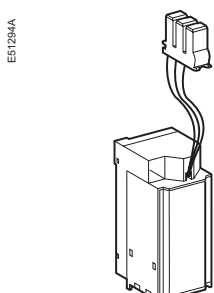

E51294A

Closing release(XF)

- optional equipment, 1 XF per device.
 - connections cables not included, see below.
 - 24/30 V AC/DC: 33659
 - 48/60 V AC/DC: 33660
 - 100/130 V AC/DC: MVS15511
 - 200/250 V AC/DC: MVS15512
 - 380/480 V AC/DC: MVS15513
 - connection cables:
 - for fixed device:47074
 - for drawout device: 47849
- the XF release instantaneously closes the circuit breaker when energised, if the device is "ready to close".
 - the coil to be fixed at the defined location only.
- device response time: 70ms+10/-15
 - operating threshold: 0.85 to 1.1xUn
 - the supply can be maintained
 - consumption:
 - pick-up: 200VA/200W
 - hold: 4.5 VA/4.5W.

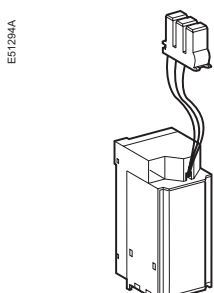

E51294A

Instantaneous undervoltage releases(MN)

- optional equipment, 1 MN per device
 - connection cables not included, see below:
 - 24/30 V AC/DC: 33668
 - 48/60 V AC/DC: 33669
 - 100/130 V AC/DC: 33670
 - 200/250 V AC/DC: 33671
 - 380/480 V AC/DC: 33673
 - connection cables:
 - for fixed device:47074
 - for drawout device:47849
- the MN release instantaneously opens the circuit breaker when its supply voltage drops below threshold values
- device response time: 90 ms±5
 - operating threshold:
 - opening: 0.35to0.7 xUn
 - closing:0.85xUn
 - consumption:
 - pick-up: 200VA/200W
 - hold: 4.5 VA/4.5W

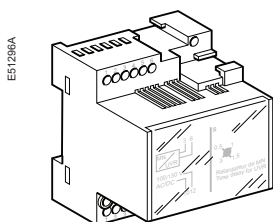

E51294A

Delay unit for MN releases

- optional equipment, 1 MN with delay unit per device.
 - delay-unit (must be ordered in addition to the MN):
 - 48/60 V AC/DC
 - 100/130V AC/DC
 - 200/250V AC/DC
 - 380/480V AC/DC
- the unit delays operation of the MN release to eliminate circuit-breaker nuisance tripping during short voltage dips
 - the unit is wired in series with the MN and must be installed outside the circuit breaker
- device response time (adjustable type): 0.5s-0.9s-1.5s-3s
 - operating threshold:
 - opening: 0.35 to 0.7 x Un
 - closing:0.85xUn
 - consumption:
 - pick-up: 200VA/200W
 - hold: 4.5 VA/4.5W

MN delay unit(1part)		R (non-adjustable)	Rr(adjustable)
AC50/60Hz	48/60VAC/DC		33680
DC	100/130 V AC/DC	33684	33681
	200/250 V AC/DC	33685	33682
	380/480 V AC/DC		33683

MVS06-16(C)

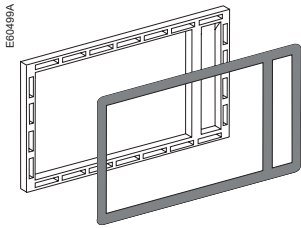

Escutcheon (CDP)

- Optional accessory, one CDP per device
- for fixed device
- for drawout device.
- The CDP increases the degree of protection to IP 40 and IK 07 (fixed and drawout devices).

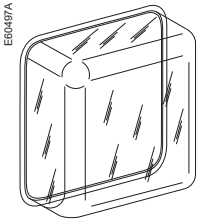

Transparent cover (CCP)

- Optional accessory, one CCP per device equipped with a CDP
- Mounted with a CDP, the CCP increases the degree of protection to IP 54 and IK 10 (fixed and drawout devices).

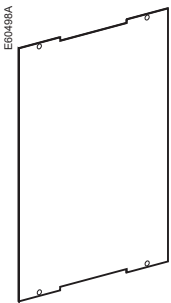

Blanking plate (OP)

- Optional accessory, one OP per device
- Used with the escutcheon, this option closes off the door cut-out of a cubicle not yet equipped with a device. It may be used with the escutcheon for both fixed and drawout devices.

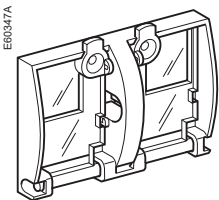

Transparent cover for pushbutton locking using a padlock, lead seal or screws

- Optional accessory, one locking cover per device
- The transparent cover blocks access (together or separately) to the pushbuttons used to open and close the device
- Locking requires a padlock, a lead seal or two screws.

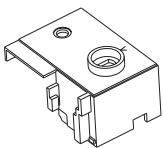

Device OFF position locking kit for keylocks

- Optional accessory: one locking kit (without keylock) per device
- Locks not included:
 - for Profalux keylocks
 - for Ronis keylocks
 - for Castell keylocks
 - for Kirk keylocks.
- The kit inhibits local or remote closing of the device
- Mounted on the chassis and accessible with the door closed, this system locks the circuit breaker in "disconnected" position using one or two keylocks.

Ronis

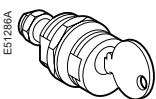

Profalux

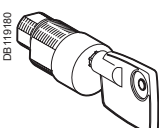

Keylocks required for the device OFF position locking kit:

- One keylock per device, Ronis or Profalux type.
- Adaptation kits alone are available for Castell and Kirk keylocks.

MVS08-40(N/H/T)

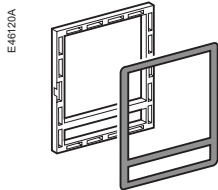

Escutcheon(CDP)

standard equipment, one Escutcheon per device
 a. for fixed device:48601
 b. for drawout device:48603

1. the Escutcheon increases the degree of protection to IP 40 and IK 07 (fixed and drawout devices).

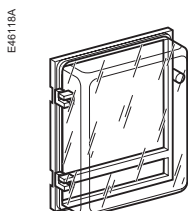

Transparent cover(CP)

optional equipment, one Transparent cover per device equipped with a Escutcheon (only for drawout devices:48604)

1. mounted with a Escutcheon, the Transparent cover increases the degree of protection to IP 55 and IK 10 (only for drawout devices).

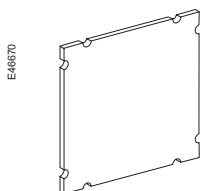

Blankingplate

Blanking plate(OP) for escutcheon

optional equipment, one Blanking plate per device equipped with a Escutcheon (only for drawout devices:48605)

1. Used with the Escutcheon, this option closes off the door cut-out of a cubicle not yet equipped with a device.

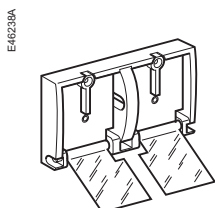

Transparent cover for pushbutton locking(VBP)

1. optional equipment, one locking cover per device:48536

1. the transparent cover blocks access (together or separately) to the push buttons used to open and close the device
2. locking requires a padlock, a lead seal or two screws.

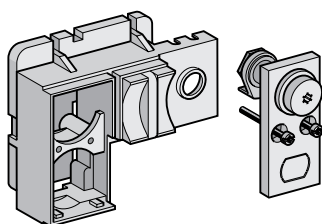

Device OFF position locking kit for keylocks(VSPO)

1. optional equipment,
 2. one locking kit per device. (key locks not included. Common for Rois/ Profalux type keylocks)
 3. part number: 64925

1. the kit inhibits local or remote closing of the device.

PROFALUX

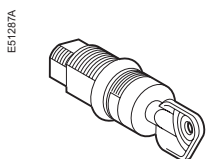

RONIS

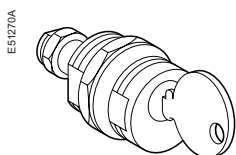

Note: Knock-out provision available in the front cover for fixing key-lock.

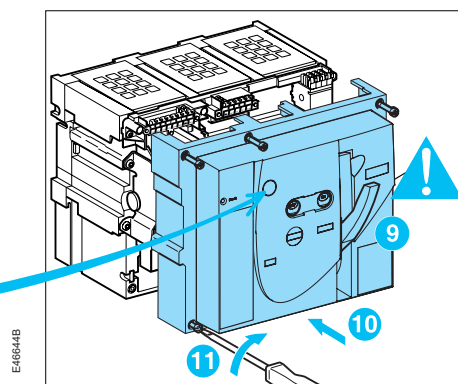

Keylocks required for the device locking kit

1. a. one key lock for locking kit.
 b. part number:
 i). Profalux:42888
 ii). Ronis:41940

2. a. two keylocks* with same profile.
 b. part number:
 i). Profalux:42878
 ii). Ronis:41950
 * one keylock mounted on the device +one keylock supplied separately for interlocking another device.

MVS06-16(C)

Top shutter closed

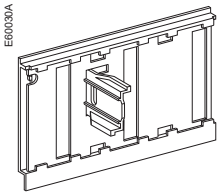

Bottom shutter closed

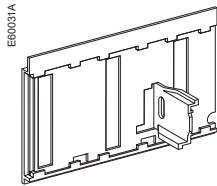

If specified when ordering the chassis, this locking function may be adapted to operate in all positions ("connected", "test" and "disconnected"), instead of in "disconnected" position alone.

Safety shutters

- Standard accessories, provided on every chassis.
- The safety shutters automatically block the access to the disconnecting contact cluster when the device is in the "disconnected" or "test" positions.
- IP 20 for chassis connections
- IP 40 for the disconnecting contact cluster.

Chassis breaker locking in "disconnected" position

- Optional accessory, one locking system per device
 - for Profalux or Ronis keylocks
 - for Castell keylocks
 - for Kirk keylocks.
- Mounted on the chassis and accessible with the door closed, this system locks the chassis in "disconnected" position using one or two keylocks.

Ronis

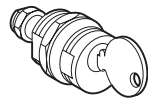
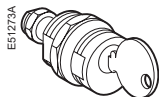
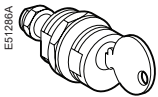

Profalux

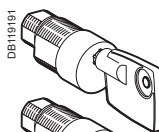
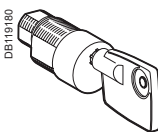

Keylocks required with the "disconnected" position locking system

- One or two keylocks per locking system
 - Ronis:
 - 1 keylock
 - 1 keylock + one identical keylock
 - 2 different key locks
 - Profalux:
 - 1 keylock
 - 1 keylock + one identical keylock
 - 2 different key locks.
- Adaptation kits alone are available for Kirk and Castell keylocks.

MVS06-16(C)

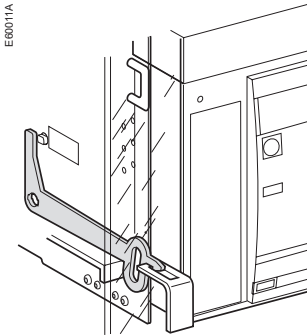

Door interlock

- Optional accessory, one door interlock per chassis
- This device inhibits opening of the cubicle door when the circuit breaker is in "connected" or "test" position.
- It may be mounted on the left or right-hand side of the chassis.

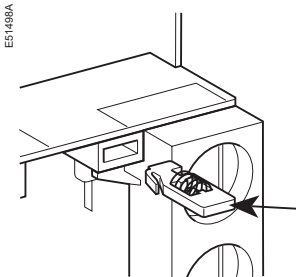

Racking interlock

- Optional accessory, one racking interlock per chassis
- This device prevents insertion of the racking handle when the cubicle door is open.
- It is mounted on the right-hand side of the chassis.

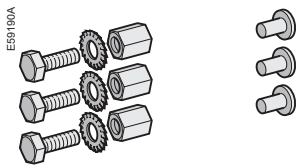

Mismatch protection

- Optional accessory, one mismatch protection device per chassis
- Mismatch protection offers twenty different combinations that the user may select to ensure that only a compatible circuit breaker is mounted on a given chassis.

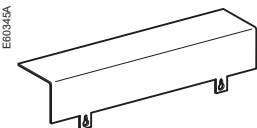

Auxiliary terminal shield (CB)

- Optional accessory, one CB shield per chassis
- The shield prevents access to the terminal block of the electrical auxiliaries.

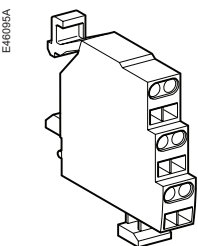

"Connected", "disconnected" and "test" position carriage switches (CE, CD, CT)

- Optional accessories, one to six carriage switches
- Standard configuration, 0 to 3 CE, 0 to 2 CD, 0 to 1 CT
- The carriage switches indicate the three positions:
 - CE: connected position
 - CD: disconnected position (when the minimum isolation distance between the main contacts and the auxiliary contacts is reached)
 - CT: test position.
- Changeover contact
- Breaking capacity at $\cos \varphi = 0.3$ (AC12 / DC12 as per IEC 60947-5-1)
 - standard, minimum current 10 mA / 24 V

V AC	240	8 A (rms)
	380	8 A (rms)

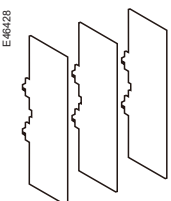

Interphase barriers (EIP)

1. optional equipment
 2. for rear connected
1. flexible insulated partitions used to reinforce isolation of connection points in installations with busbars.
 2. they are installed vertically between rear connection terminals.

MVS08-40(N/H/T)

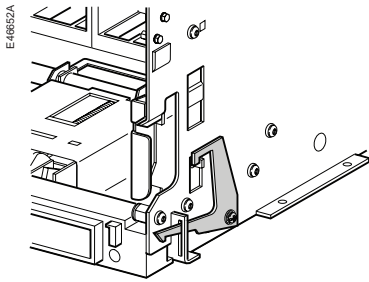

Door interlock(VPEC)

1. optional equipment, one door interlock per chassis
2. part number:47914
1. this device inhibits opening of the cubicle door when the circuit breaker is in "connected" or "test" position
1. it may be mounted on the left or right-hand side of the chassis.

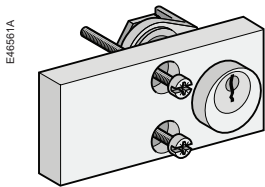

Circuit breaker locking in "disconnected" position(VSPD)

1. optional equipment, one locking kit per device for Profalux or Ronis keylocks(not included)
2. part number:48564
3. key locks to be ordered separately.
1. mounted on the chassis and accessible with the door closed,this system locks the circuit breaker in "disconnected" position using one keylock
2. the "disconnected" position locking system may be modified to lock the circuit breaker in all three positions.

Profalux

Ronis

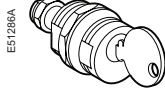
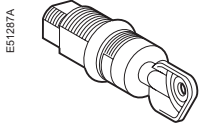

Keylocks required with the "disconnected" position locking system

1. a. one lock for locking system
b. part number:
i). Profalux: 42888
ii). Ronis: 41940
2. a. two keylocks with same profile.
b. part number:
i). Profalux: 42878
ii). Ronis: 41950
* one keylock mounted on the device
+one keylock supplied separately for interlocking another device.

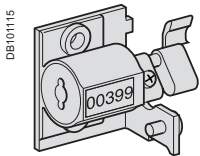

Operation counter(CDM)

1. optional equipment, per device
The operation counter sums the number of operating cycles and is visible on the front panel. It is compatible with manual and electrical control functions.
This option is compulsory for all the source-changeover systems.
2. part number: : 48535

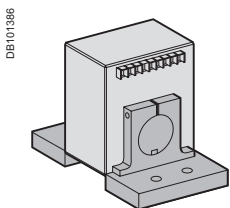

External neutral sensors (TCE)

External sensor for earth-fault protection

The sensors, used with the 3P circuit breakers, are installed on the neutral conductor for:

1. residual type earth-fault protection (with ET/ETA/ETV 6G Trip System)
The rating of the sensor (CT) must be compatible with the rating of the circuit breaker:
a. MVS08 to MVS 20: CT 400/2000; UV number: 34035
b. MVS25 to MVS 40: CT 1000/4000; UV number: 34036

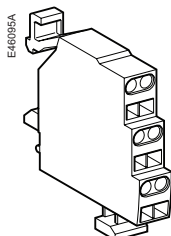

"Connected", "disconnected" and "test" position carriage switches (CE, CD, CT)

1. optional equipment, one to nine carriage switches
Standard configuration, 0 to 3 CE, 0 to 3 CD, 0 to 3 CT
2. part number (connection cables not included)
 - a. 1 carriage switch 33170
1. the carriage switches indicate the three positions:
CE: connected position
CD: disconnected position (when the minimum isolation distance between the main contacts and the auxiliary contacts is reached)
CT: test position (in this position, the power circuits are disconnected and the auxiliary circuits are connected)
2. function defined based on the location in chassis.
 1. changeover contact
 2. rated current: 8 A
 3. breaking capacity 50/60 Hz for AC power (AC12 as per IEC60947-5-1):
240 V: 8 A (rms)
380 V/415 V: 8 A (rms)
 4. breaking capacity for DC power (DC12 as per IEC60947-5-1):
125 V: 0.8 A.

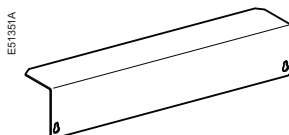

Auxiliary terminal shield (CB)

1. optional equipment, one shield per chassis
2. part number:
3 pole: 64942
4 pole: 48596
1. the shield prevents access to the terminal block of the electrical auxiliaries.

E51334A Top shutter closed

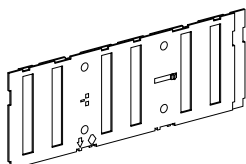

Bottom shutter closed

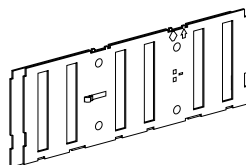

Safety shutters (VO)

1. standard equipment
2. set of shutters for top and bottom:
 - a. MVS08/MVS40
3 poles
4 poles
 - b. part number:
3 poles: 48721
4 poles: 48723
1. mounted on the chassis, the safety shutters automatically block access to the disconnecting contact cluster when the device is in the "disconnected" or "test" positions.
1. IP20.

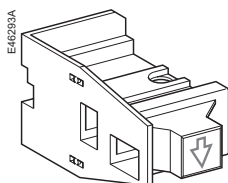

Shutter locking blocks

1. optional equipment:
2. blocks for MVS08 to MVS40
3. part number: 48591
1. the block may be padlocked. It:
 - prevents connection of the device
 - locks the shutters in the closed position.

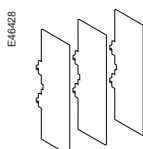

Interphase barriers (EIP)

1. optional equipment
2. for rear connected
 - fixed (3 pole & 4 pole): 48599
 - draw-out (3 pole & 4 pole): 48600
1. flexible insulated partitions used to reinforce isolation of connection points in installations with busbars.
2. they are installed vertically between rear connection terminals

These operations must be carried out in particular before using a EasyPact MVS device for the first time.

A general check of the circuit breaker takes only a few minutes and avoids any risk of mistakes due to errors or negligence.

A general check must be carried out:

1. prior to initial use
2. following an extended period during which the circuit breaker is not used.

A check must be carried out with the entire switchboard de-energised.

In switchboards with compartments, only those compartments that may be accessed by the operators must be de-energised.

Electrical tests

Insulation and dielectric-withstand tests must be carried out immediately after delivery of the switchboard. These tests are precisely defined by international standards and must be directed and carried out by a qualified expert.

Prior to running the tests, it is absolutely necessary to disconnect all the electrical auxiliaries of the circuit breaker (MCH, MX, XF, MN,).

Switchboard inspection

Check that the circuit breakers are installed in a clean environment, free of any installation scrap or items (tools, electrical wires, broken parts or shreds, metal objects, etc.).

Conformity with the installation diagram

Check that the devices conform with the installation diagram:

1. breaking capacities indicated on the rating plates
2. identification of the ET/ETA/ETV Trip System (type, rating)
3. presence of any optional functions (remote ON/OFF with motor mechanism, auxiliaries, etc.)
4. protection settings (long time, short time, instantaneous, earth fault)
5. identification of the protected circuit marked on the front of each circuit breaker.

Condition of connections and auxiliaries

Check device mounting in the switchboard and the tightness of power connections.

Check that all auxiliaries and accessories are correctly installed:

1. electrical auxiliaries*
2. terminal blocks
3. connections of auxiliary circuits.

Operation

Check the mechanical operation of the circuit breakers:

1. opening of contacts
2. closing of contacts.

Check on the ET/ETA/ETV Trip System

Check the ET/ETA/ETV Trip System of each circuit breaker using this user manual (from page 31 to page 38).

* Make sure that XF (closing coil) & MX (opening coil) are installed at the right locations. Avoid installation of XF release at MX position. Failure to follow the instruction of MN-MX-XF can not keep the circuit breaker at OFF position by remote control that resulting equipment damage or risk of life.

What to do when the circuit breaker trips

Note the fault

Faults are signalled locally and remotely by the indicators and auxiliary contacts installed on circuit breakers (depending on each configuration). See page 13 in this manual.

Identify the cause of tripping

A circuit must never be reclosed (locally or remotely) before the cause of the fault has been identified and cleared.

A fault may have a number of causes.

1. depending on the type of trip system, fault diagnostics are available. See page 36 of this manual for details on the type of fault indications.
2. depending on the type of fault and the criticality of the loads, a number of precautionary measures must be taken, in particular the insulation and dielectric tests on a part of or the entire installation. These checks and test must be directed and carried out by qualified personnel.

Inspect the circuit breaker following a short-circuit

1. check the arc chutes (see page 95).
2. check the contacts (see page 95).
3. check the disconnecting-contact clusters (see page 96).
4. check the tightness of connections (50 N.m see the device installation manual)

Reset the circuit breaker

The circuit breaker can be reset locally.

See page 10 for information on how the circuit breaker can be reset.

Recommended program for devices used under normal operating conditions:
Ambient temperature: -5° C / +60°C Normal atmosphere

Periodic inspections required

Interval	Operations	Procedure
each year	<ol style="list-style-type: none"> open and close the device locally and remotely, successively using the various auxiliaries test the operating sequences test ET/ETA/ETV Trip System using the mini test kit 	see pages 12 and 13 see page 10 see page 36
every two years	<ol style="list-style-type: none"> check the arc chutes check the main contacts check the disconnecting-contact clusters check the tightness of connections(50 N.m) 	see page 95 see page 95 see page 96 see the device installation manual

Parts requiring replacement, depending on the number of operating cycles

The following parts must be replaced periodically to lengthen the service life of the device (maximum number of operating cycles).

Part	Intervening entity	Description or procedure
arc chutes	1. user	see page 95.
main contacts	<ol style="list-style-type: none"> inspection: user replacement: Schneider After Sales Support 	see page 95.
MCH gear motor	1. user	see page 11.
mechanical interlocks	1. user	see Mechanical interlocking manual.
connecting-rod springs	1. Schneider After Sales Support	
MX/MN/XF	1. user	see pages 12, 13.

Part replacement must be programmed on the basis of the data below, listing the service life of the various parts in numbers of O/C cycles at the rated current.

Number of O/C cycles at the rated current

Type of circuit breaker	Maximum service life	Service life of various parts*			
		Arc chutes	Main contacts	Connecting-rod springs, MCH	MX/XF releases
MVS 06-16 (C)	10000	5000	5000	5000	5000
MVS 08-16 (N/H/T)	20000	6000	6000	10000	10000
MVS 20-40 (N/H/T)	20000	5000	5000	10000	10000

* the service life of arc chutes & main contacts are at an operational voltage of 440V AC.

Before undertaking any maintenance work, de-energise the installation and fit locks or warnings in compliance with all applicable safety standards.

Arc chutes MVS 06-16 (C)

1. remove the 2 fixing screws:

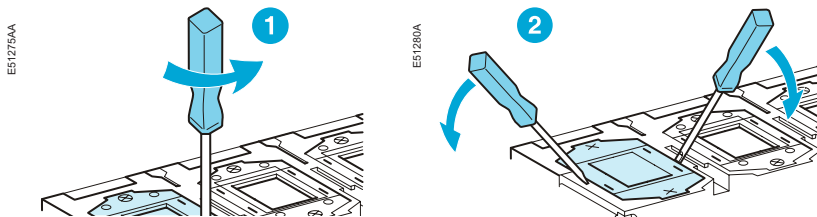

2. check the arc chutes:
chamber not cracked separators not corroded.

If necessary, replace the arc chutes.

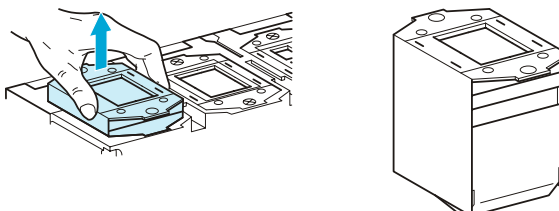

Arc chutes MVS 08-40 (N/H/T)

1. remove the 2 fixing screws:

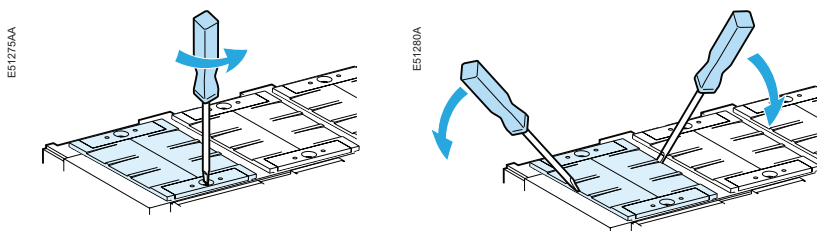

2. check the arc chutes:
chamber not cracked separators not corroded.

If necessary, replace the arc chutes.

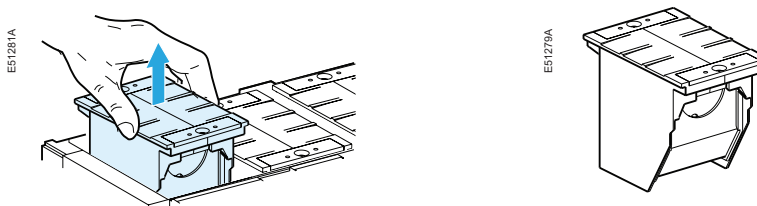

If the contacts are worn, have the concerned poles replaced by the Schneider service centre.

Wear of main contacts

1. remove the arc chutes
2. close the device and check the contacts

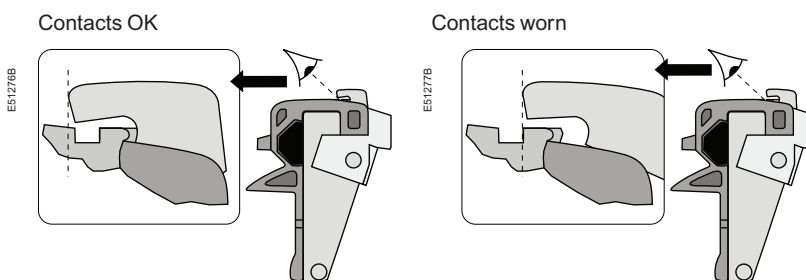

Disconnecting-contact clusters

1. grease the contacts using the grease, supplied by Schneider Electric
2. check the contacts as follows:
 - a. open the circuit breaker
 - b. de-energise the busbars
 - c. disconnect the circuit breaker
 - d. remove the circuit breaker
 - e. check the contact fingers (no sign of copper should be visible)
Replace any worn clusters.
3. the position of the clusters must correspond to the table below.

Rating Type	MVS06	MVS08	MVS10	MVS12	MVS16	MVS20	MVS25	MVS32	MVS40
C	layout n°1	layout n°1	layout n°1	layout n°1	layout n°6				
N		layout n°2	layout n°2	layout n°2	layout n°2	layout n°2	layout n°3	layout n°4	layout n°5
H		layout n°2	layout n°2	layout n°2	layout n°2	layout n°2	layout n°2	layout n°4	layout n°5
CA	layout n°1	layout n°1	layout n°1	layout n°1	layout n°6				
NA		layout n°2	layout n°2	layout n°2	layout n°2	layout n°2	layout n°3	layout n°4	layout n°5
HA		layout n°2	layout n°2	layout n°2	layout n°2	layout n°2	layout n°2	layout n°4	layout n°5

layout n°1

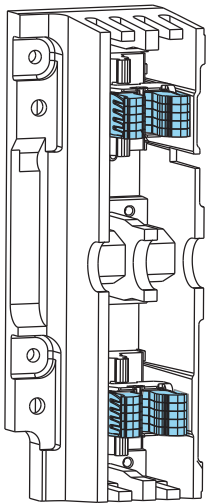

layout n°2

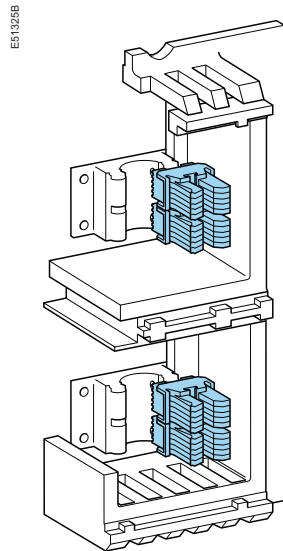

layout n°3

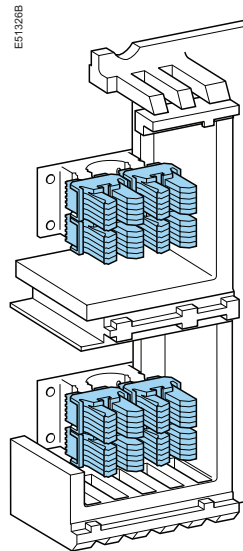

layout n°4

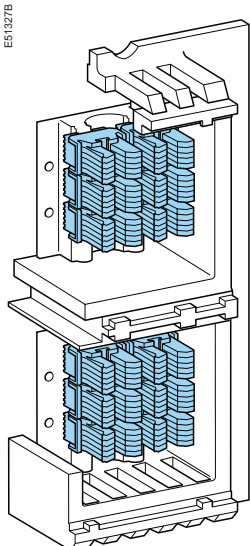

layout n°5

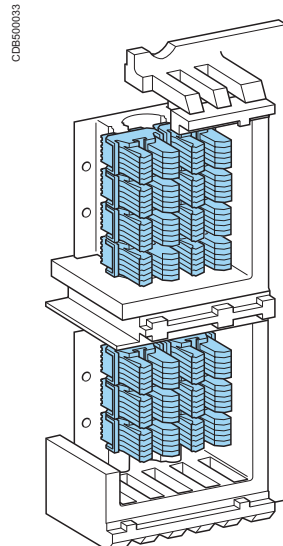

layout n°6

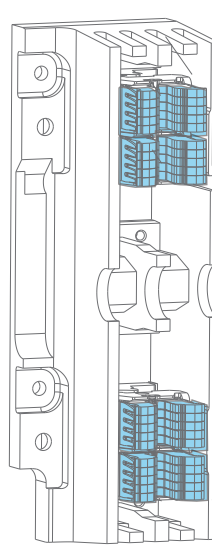

MVS06-16(C)

Electrical accessories

The electrical accessories that may require replacement are the following:

1. MCH gear motor
2. MX opening release
3. XF closing release
4. MN under voltage release.

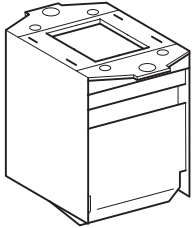

Arc chutes

- 1 chute per pole.

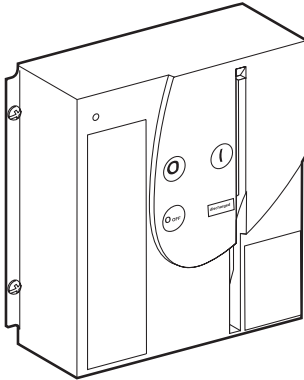

Front

- 1 per 3- or 4- pole device.



Charging handle

- 1 per device.

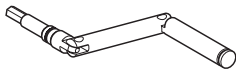

Crank

- 1 per device.

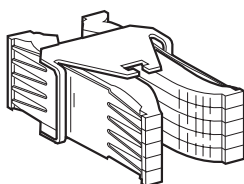

Disconnecting-contact clusters

- number per circuit breaker, see table page 96.

MVS08-40(N/H/T)

Electrical accessories

The electrical accessories that may require replacement are the following:

1. MCH gear motor
2. MX opening release
3. XF closing release
4. MN under voltage release.

See page 85 in the "Auxiliaries for remote operation" section for their characteristics and part numbers.

Arc chutes

1. arc chute: MVS08-40
part number: MVS21807
1. 3 or 4 chutes per circuit breaker

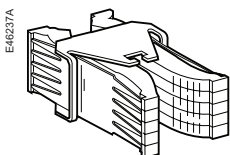
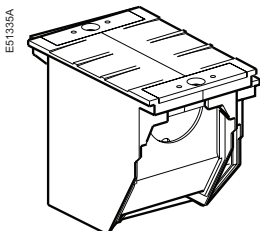

Disconnecting-contact clusters for standard MVS

1. cluster :
part number: 33166
1. number per circuit breaker, see table page 96.

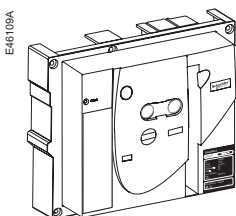

Front cover with knock-out provision for key lock(standard)

1. front cover for 3-or 4 poles devices.
part number: MVS21808
1. one per device.

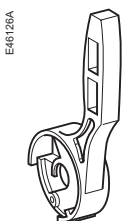

Charging handle

1. Manual operating spring charging handle.
part number: 47940
1. one handle per device.

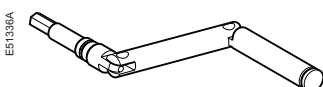

Crank

1. crank per device.
part number: 47944
1. one per device.

Problem	Problem	Problem
circuit breaker cannot be closed locally or remotely	1. circuit breaker padlocked or keylocked in the "open" position	a. disable the locking function
	2. circuit breaker interlocked mechanically in a source changeover system	a. check the position of the other circuit breaker in the changeover system b. modify the situation to release the interlock
	3. circuit breaker not completely connected	a. terminate racking in (connection) of the circuit breaker
	4. the reset button signalling a fault trip has not been reset	a. clear the fault b. push the reset button on the front of the circuit breaker
	5. stored energy mechanism not charged	a. charge the mechanism manually b. if it is equipped with a an MCH gear motor, check the supply of power to the motor. If the problem persists, replace the gear motor(MCH)
	6. MX opening shunt release permanently supplied with power	a. there is an opening order. Determine the origin of the order. The order must be cancelled before the circuit breaker can be closed
	7. MN under voltage release not supplied with power	a. there is an opening order. Determine the origin of the order. b. check the voltage and the supply circuit ($U > 0.85 U_n$). If the problem persists,replace the release
	8. XF closing release continuously supplied with power,but circuit breaker not "ready to close" (XF not wired in series with PF contact)	a. cut the supply of power to the XF closing release, then send the closing order again via the XF, but only if the circuit breaker is "ready to close"
circuit breaker cannot be closed remotely but can be closed locally using the closing pushbutton on breaker	1. closing order not executed by the XF closing release	a. check the voltage and the supply circuit ($0.85-1.1U_n$). If the problem persists, replace the XF release
unexpected tripping without activation of the reset button signalling a fault trip	1. MN undervoltage release supply voltage too low	a. check the voltage and the supply circuit ($U > 0.85 U_n$)
	2. load-shedding order sent to the MX opening release by another device	a. check the overall load on the distribution system b. if necessary, modify the settings of devices in the installation
	3. unnecessary opening order from the MX opening release	a. determine the origin of the order
unexpected tripping with activation of the reset button signalling a fault trip	1. overload	a. determine and clear the causes of the fault
	2. earth fault	b. check the condition of the circuit breaker before putting it back into service
instantaneous opening after each attempt to close the circuit breaker with activation of the reset button signalling a fault trip	3. short-circuit detected by Trip unit	
	1. thermal memory	a. refer to page no.34-35 of this user manual.
	2. transient over current when closing	b. press the reset button a. modify the distribution system or the Trip unit settings. b. check the condition of the circuit breaker before putting it back into service
	3. closing on a short-circuit	c. press the reset button a. clear the fault b. check the condition of the circuit breaker before putting it back into service c. press the reset button

Problem	Probable causes	Solutions
circuit breaker cannot be opened remotely, but can be opened locally	1. opening order not executed by the MX opening release	check the voltage and the supply circuit (0.7-1.1Un). If the problem persists, replace the MX release
	2. opening order not executed by the MN undervoltage release	drop in voltage insufficient or residual voltage ($U < 0.35U_n$) across the terminals of the undervoltage release. If the problem persists, replace the MN release
circuit breaker can not be opened locally	1. operating mechanism malfunction or welded contacts	contact a Schneider service centre
circuit breaker can not be reset locally	1. insufficient supply voltage for the MCH gear motor	check the voltage and the supply circuit (0.85 - 1.1 Un). If the problem persists, replace the MCH release
nuisance tripping of the circuit breaker with activation of the reset button signalling a fault trip	1. reset button not pushed-in completely	push the reset button in completely
impossible to insert the crank in connected, test or disconnected position	1. a padlock or keylock is present on the chassis or a door interlock is present	disable the locking function
impossible to turn the crank	1. the position release button has not been pressed	press the position release button
circuit breaker cannot be removed from chassis	1. circuit breaker not in disconnected position	turn the crank until the circuit breaker is in disconnected position and the position release button is popped-out.
	2. the rails are not completely out	pull the rails all the way out
circuit breaker cannot be connected (racked in)	1. the safety shutters are locked	remove the lock(s)
	2. the disconnecting-contact clusters are incorrectly positioned	reposition the clusters
	3. chassis locked in disconnected position	disable the chassis locking function
circuit breaker cannot be locked in disconnected position	4. the position release button has not been pressed, preventing rotation of the crank	press the position release button
	5. the circuit breaker has not been sufficiently inserted in the chassis	insert the circuit breaker completely so that it is engaged in the racking mechanism
	1. the circuit breaker is not in the right position	check the circuit breaker position by making sure the position release button is popped-out.
circuit breaker cannot be locked in connected, test or disconnected position	2. the crank is still in the chassis	remove the crank and store it
	1. check that locking in any position is enabled	contact a Schneider service centre
the crank cannot be inserted to connect or disconnected the circuit breaker	2. the circuit breaker is not in the right position	check the circuit breaker position by making sure the position release button is popped-out.
	3. the crank is still in the chassis	remove the crank and store it
the right-hand rail (chassis alone) or the circuit breaker cannot be drawn out	1. the rails are not completely in	push the rails all the way in
the right-hand rail (chassis alone) or the circuit breaker cannot be drawn out	1. the crank is still in the chassis	remove the crank and store it

EF51260B

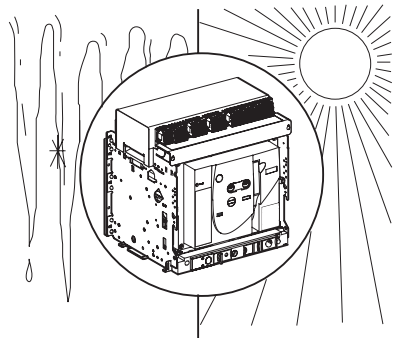

Ambient temperature

EasyPact MVS devices can operate under the following temperature conditions:

1. the electrical and mechanical characteristics are stipulated for an ambient temperature of -5°C to $+60^{\circ}\text{C}$
2. circuit-breaker closing is guaranteed down to -35°C
3. EasyPact MVS (without Trip System) can be stored in an ambient temperature of -40°C to $+85^{\circ}\text{C}$
4. the Trip System can be stored in an ambient temperature of -25°C to $+85^{\circ}\text{C}$.

EF51264B

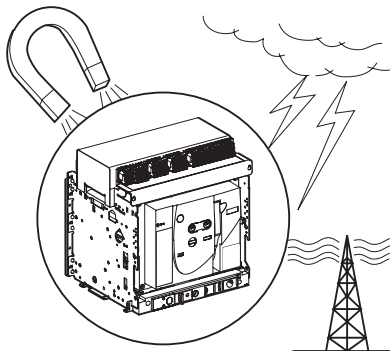

Electromagnetic disturbances

EasyPact MVS devices are protected against:

1. overvoltages caused by devices that generate electromagnetic disturbances
2. overvoltages caused by atmospheric disturbances or by a distribution-system outage (e.g. failure of a lighting system)
3. devices emitting radio waves (radios, walkie-talkies, radar, etc.)
4. electrostatic discharges produced by users.

EasyPact MVS devices have successfully passed the electromagnetic-compatibility tests (EMC) defined by the following international standards:
IEC 60947-2, appendix F

The above tests guarantee that:

1. no nuisance tripping occurs
2. tripping times are respected.

Cleaning

1. non-metallic parts:
never use solvent, soap or any other cleaning product. Clean with a dry cloth only
2. metal parts:
clean with a dry cloth whenever possible. If solvent, soap or any other cleaning product must be used, make sure that it does not come into contact with non-metallic parts.

Schneider Electric Industries SAS

35, rue Joseph Monier
CS 30323
92506 Rueil Malmaison Cedex
France

RCS Nanterre 954 503 439
Capital social 928 298 512 €
www.se.com

As standards, specifications and designs change from time to time, please ask for confirmation of the information given in this publication.



This document has been printed on ecological paper

Design: Schneider Electric
Photos: Schneider Electric
Printed:

MVS21734



09-2022