

TeSys Control

Star-delta starters - up to 132 kW ⁽¹⁾

Product references

Open motor starters

FB123608.eps



LC3D32A●●

Plate mounted starters without isolating device

Maximum operating rate: 30 starts/hour. Maximum starting time: 30 seconds.

Standard power ratings of squirrel cage motors Mains voltage - delta connection				Auxiliary contacts available on each contactor						Star delta mechanical interlock	Basic reference, to be completed by adding the voltage code ^{(2) (3)}	Weight
220/230 V	380/400 V	415 V	440 V	line KM2	delta KM3	star KM1						
kW	kW	kW	kW								kg	
4	7.5	7.5	7.5	-	-	-	- ⁽⁴⁾	-	1	With	LC3D09A●●	1.530
5.5	11	11	11	-	-	-	- ⁽⁴⁾	-	1	With	LC3D12A●●	1.530
11	18.5	22	22	-	-	-	- ⁽⁴⁾	-	1	With	LC3D18A●●	1.730
15	25	30	30	-	-	-	- ⁽⁴⁾	-	1	With	LC3D32A●●	2.030
37	75	75	75	-	1	1	- ⁽⁴⁾	-	- ⁽⁴⁾	Without	LC3D80●●	5.200
										With	LC3D80●●A64	5.400
63	110	110	110	-	1	1	- ⁽⁴⁾	-	- ⁽⁴⁾	Without	LC3D115●● ⁽⁵⁾	11.800
										With	LC3D115●●A64 ⁽⁵⁾	12.100
75	132	132	147	-	1	1	- ⁽⁴⁾	-	1 ⁽⁴⁾	Without	LC3D150●● ⁽⁵⁾	12.100
										With	LC3D150●●A64 ⁽⁵⁾	12.100

Rail mounted starters (35 mm rail) without isolating device

Maximum operating rate: 12 starts/hour. Maximum starting time: 30 seconds.

Standard power ratings of squirrel cage motors Mains voltage - delta connection				Auxiliary contacts available on each contactor						Star delta mechanical interlock	Basic reference, to be completed by adding the voltage code ^{(2) (3)}	Weight
220/230 V	380/400 V	415 V	440 V	line KM2	delta KM3	star KM1						
kW	kW	kW	kW								kg	
4	7.5	7.5	7.5	-	-	-	-	-	1	With	LC3K09●●	0.740
4	7.5	7.5	7.5	-	-	-	- ⁽⁴⁾	-	1	With	LC3D090A●●	1.530
5.5	11	11	11	-	-	-	- ⁽⁴⁾	-	1	With	LC3D120A●●	1.530
11	18.5	22	22	-	-	-	- ⁽⁴⁾	-	1	With	LC3D180A●●	1.730
15	25	30	30	-	-	-	- ⁽⁴⁾	-	1	With	LC3D320A●●	2.030

⁽¹⁾ Protection must be provided by the addition of a thermal overload relay, to be ordered separately. Select appropriate overload relay for setting at 0.58 of the full load rated motor current (see pages B11/4 and B11/5).

⁽²⁾ Standard control circuit voltages:

Volts ~ 50/60 Hz 24 36 42 48 110 220 230 240 380 400 415 440

Star-delta starters LC3K09

Code B7 C7 D7 E7 F7 M7 P7 U7 - - - -

Star-delta starters LC3D09A...D150, LC3D090A...D320A

Code B7 - D7 E7 F7 M7 P7 U7 Q7 V7 N7 R7

For other voltages, please consult your Regional Sales Office.

⁽³⁾ Please check the availability of your variant in the index page A2/16. The SEARCH function of your viewer can be used.

⁽⁴⁾ One auxiliary contact block type LADN can also be fitted, see page B8/36.

⁽⁵⁾ These starters consist of contactors LC1D115 or D150 without connectors.

Open motor starters

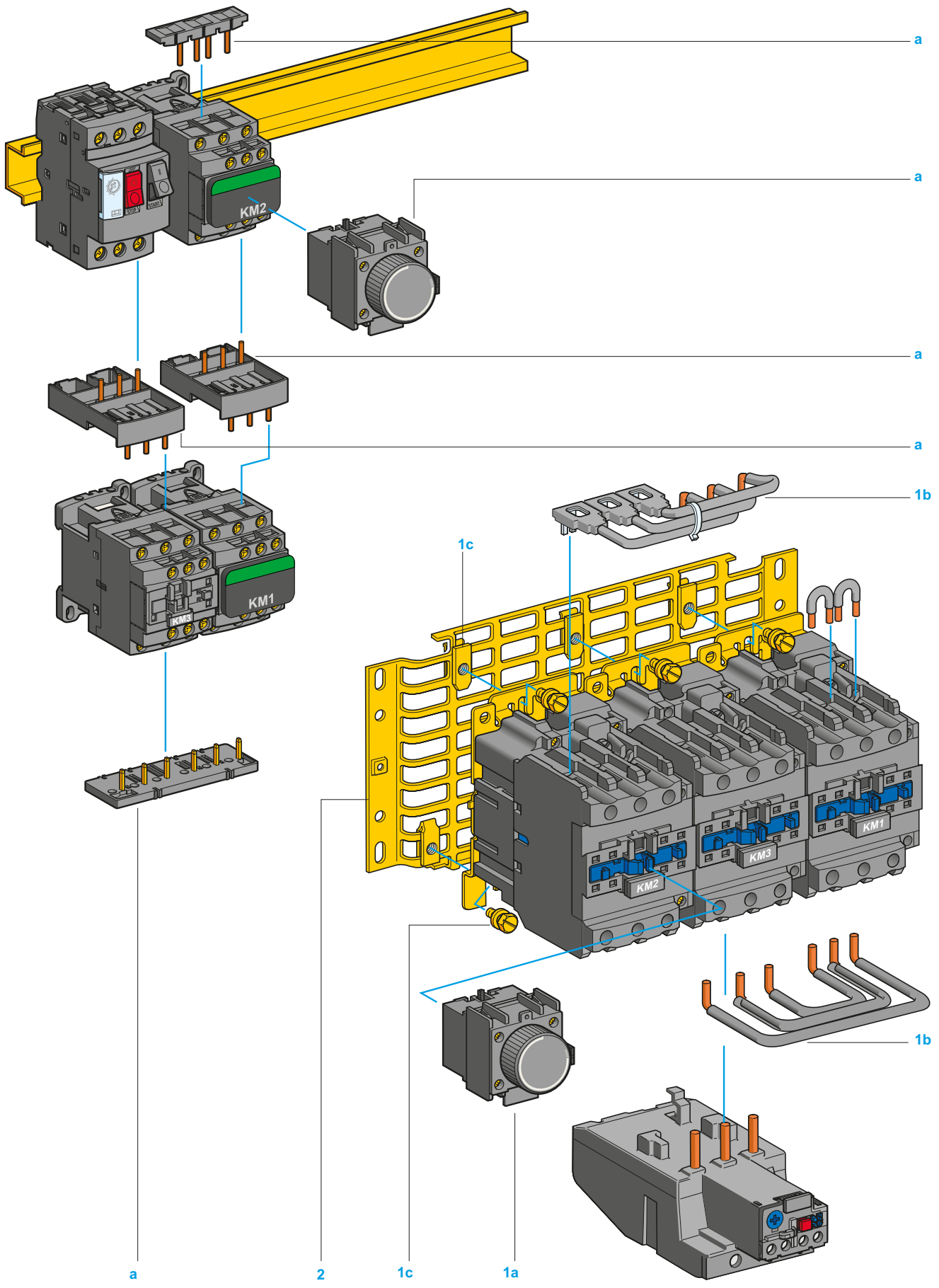

Star-delta starters without mechanical interlock, for customer assembly on plate or on mounting rail ⁽²⁾

Starters for direct combination with a circuit breaker

Maximum operating rate: 30 starts/hour. Maximum starting time: 30 seconds

Standard power ratings of squirrel cage motors ⁽³⁾	Thermal-magnetic motor circuit breaker <i>References in italics are available in CEE zone only</i>	Contactors (basic references, to be completed by adding the voltage code) ⁽⁴⁾		
		line	delta	star
Mains voltage-delta connection				
400/415 V	440 V			
kW	kW	KM2	KM3	KM1
7.5	7.5	GV2ME20 or <i>GV2ME20AP</i>	LC1D09●●	LC1D09●●
–	9	GV2ME21 or <i>GV2ME21AP</i>	LC1D12●●	LC1D09●●
9	11	GV2ME21 or <i>GV2ME21AP</i>	LC1D12●●	LC1D12●●
11	–	GV2ME22 or <i>GV2ME22AP</i>	LC1D12●●	LC1D09●●
15	15	GV2ME32 or <i>GV2ME32AP</i>	LC1D18●●	LC1D09●●

Separate component

Description	Illustration item no.	Reference
Mounting kit comprising: power circuit connections and 1 time delay contact block LADS2	a	LAD912GV

Starters for mounting separately from upstream protection

Maximum operating rate: 30 starts/hour. Maximum starting time: 30 seconds.

Standard power ratings of squirrel cage motors ⁽³⁾				Contactors (basic references, to be completed by adding the voltage code) ⁽⁴⁾			Separate components (see below)
Mains voltage - delta connection				line	delta	star	
220/230 V	380/400 V	415 V	440 V	line	delta	star	
kW	kW	kW	kW	KM2	KM3	KM1	Component types
4	7.5	7.5	7.5	LC1D09●●	LC1D09●●	LC1D09●●	D09
5.5	11	11	11	LC1D18●● ⁽⁶⁾	LC1D12●●	LC1D09●●	D12
11	18.5	22	22	LC1D25●● ⁽⁷⁾	LC1D25●● ⁽⁷⁾	LC1D09●●	D18
15	25	30	30	LC1D32●●	LC1D32●●	LC1D18●●	D32
18.5	37	37	37	LC1D40A●●	LC1D40A●●	LC1D40A●●	D40
30	55	59	59	LC1D50A●●	LC1D50A●●	LC1D40A●●	D50
37	75	75	75	LC1D80●●	LC1D80●●	LC1D50A●●	D80
63	110	110	110	LC1D115●●	LC1D115●●	LC1D80●●	D115 ⁽⁵⁾
75	132	132	147	LC1D150●●	LC1D150●●	LC1D115●●	D150 ⁽⁵⁾

Separate components

Description	Illustration item no.	For components type ⁽⁵⁾	Reference	Without timer LADS2
Mounting kit comprising: - 1 time delay contact block LADS2 (D09...D80) ⁽³⁾ , - power circuit connections (D09...D80), - screws and clamps for fixing contactors to the plate (D40...D80).	1 a	LC1D09 to D38 ⁽⁸⁾	LAD91217	LAD91218
	1 b	LC1D09 to D38 ⁽⁹⁾	LAD93217	LAD93218
	1 c	D40 and D50	LA9D5017	–
		D80	LA9D8017	–
Equipment mounting plates	2	LC1D09 to D38 D80	LA9D12974 LA9D80973	

⁽¹⁾ Protection must be provided by the addition of a thermal overload relay, to be ordered separately.

Select appropriate overload relay for setting at 0.58 of the full load rated motor current, see pages B11/4 and B11/5.

⁽²⁾ For mounting, assembly and cabling: please refer to installation instructions supplied with the equipment.

⁽³⁾ See comments on page A2/22.

⁽⁴⁾ See page B8/22.

⁽⁵⁾ For D115 and D150 components, see illustration and separate parts on pages A2/12 and A2/13.

⁽⁶⁾ A D12 component is adequate for the application, but use of a D18 is recommended. (connection capacity, correct use of power connection kit and connections).

⁽⁷⁾ A D18 component is adequate for the application, but use of a D25 is recommended. (connection capacity, correct use of power connection kit and connections).

⁽⁸⁾ For assembly of 3 contactors of the same physical size (depth).

⁽⁹⁾ For assembly of 3 contactors with star contactor physically smaller (depth).

Open motor starters

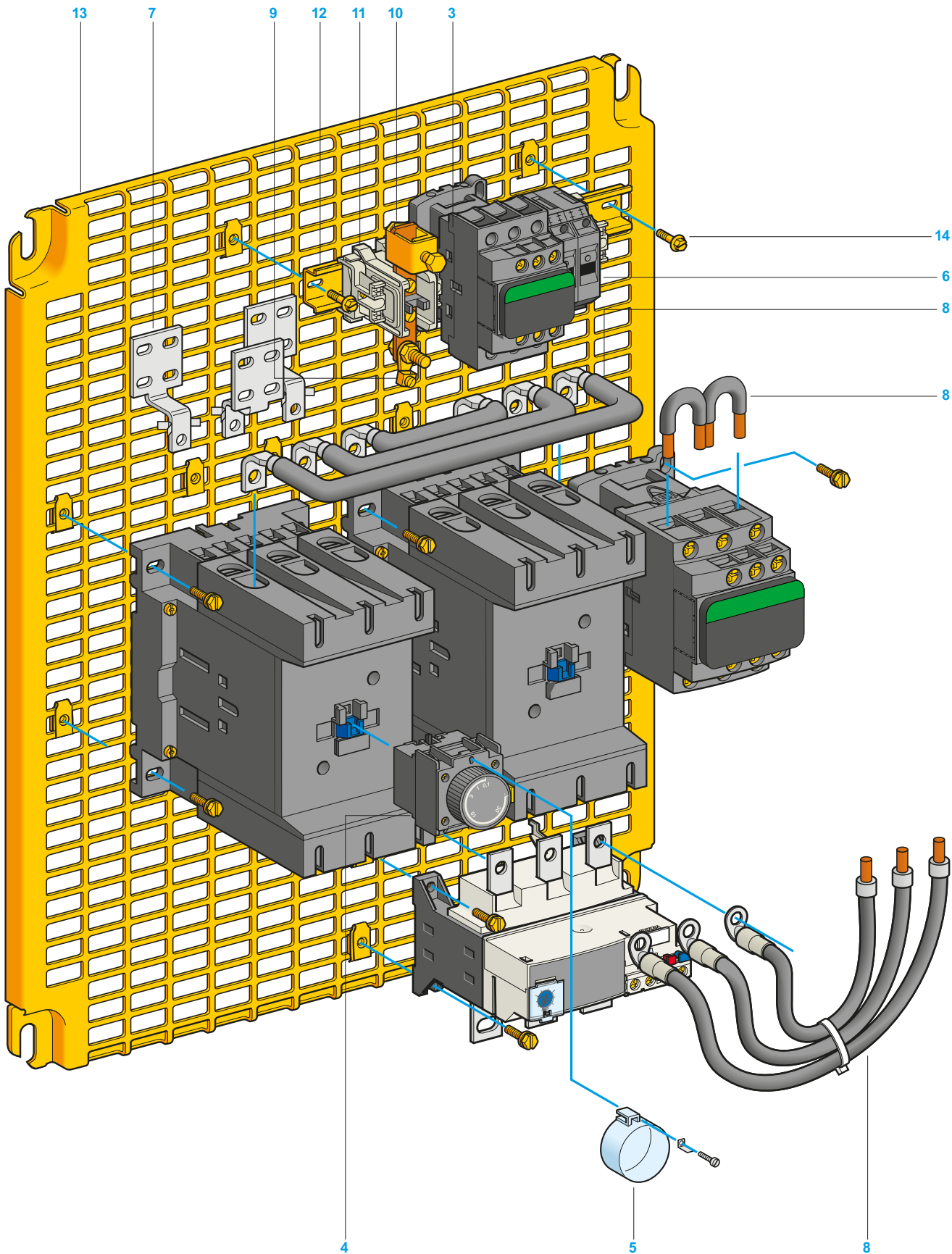

Starters for mounting separately from upstream protection						
Separate components (continued)						
Description	Illustration item no.	For use on	No.	Sold in lots of	Unit reference	Weight kg
Instantaneous auxiliary contact blocks 1 N/O	1	D115 (star)	1	1	LADN10	0.020
Control relay	3	D115, D150	1	1	CAD32	0.320
Time delay auxiliary contact blocks	4	D115, D150	1	1	LADT2	0.060
Lead sealing kit for time delay auxiliary contact blocks	5	D115, D150	1	1	LA9D901	0.005
Thermal magnetic circuit breaker for control circuit (200...415 V)	6	D115, D150	2	6	GB2CB05	0.060
Set of 3 connectors for wider terminations (optional)	7	D115, D150	1	1	LA9FG980	0.200
Set of power connections with fixing accessories	8	D115	1	1	LA9D11517	0.800
		D150	1	1	LA9D15017	1.050
Spare volt free terminals	9	D115, D150	1	10	DZ3HA3	0.007
			2	10	DZ3GA3	0.006
Lug-connector terminal block	10	D115, D150	1	10	AB1BC9535	0.236
End stop	11	D115, D150	3	100	AB1AB8M35	0.005
Mounting rail 35 mm	12	D115, D150	1	10	NSYDPR25	0.210
Pre-slotted mounting plate	13	D115, D150	1	1	AM3PA65	1.950
Screw with captive washer	14	D115, D150	12	100	AF1VA618	0.006
			2	100	AF1VA410	0.002

⁽¹⁾ Protection must be provided by the addition of a thermal overload relay, to be ordered separately. Select appropriate overload relay for setting at 0.58 of the full load rated motor current, see pages B11/4 and B11/5.



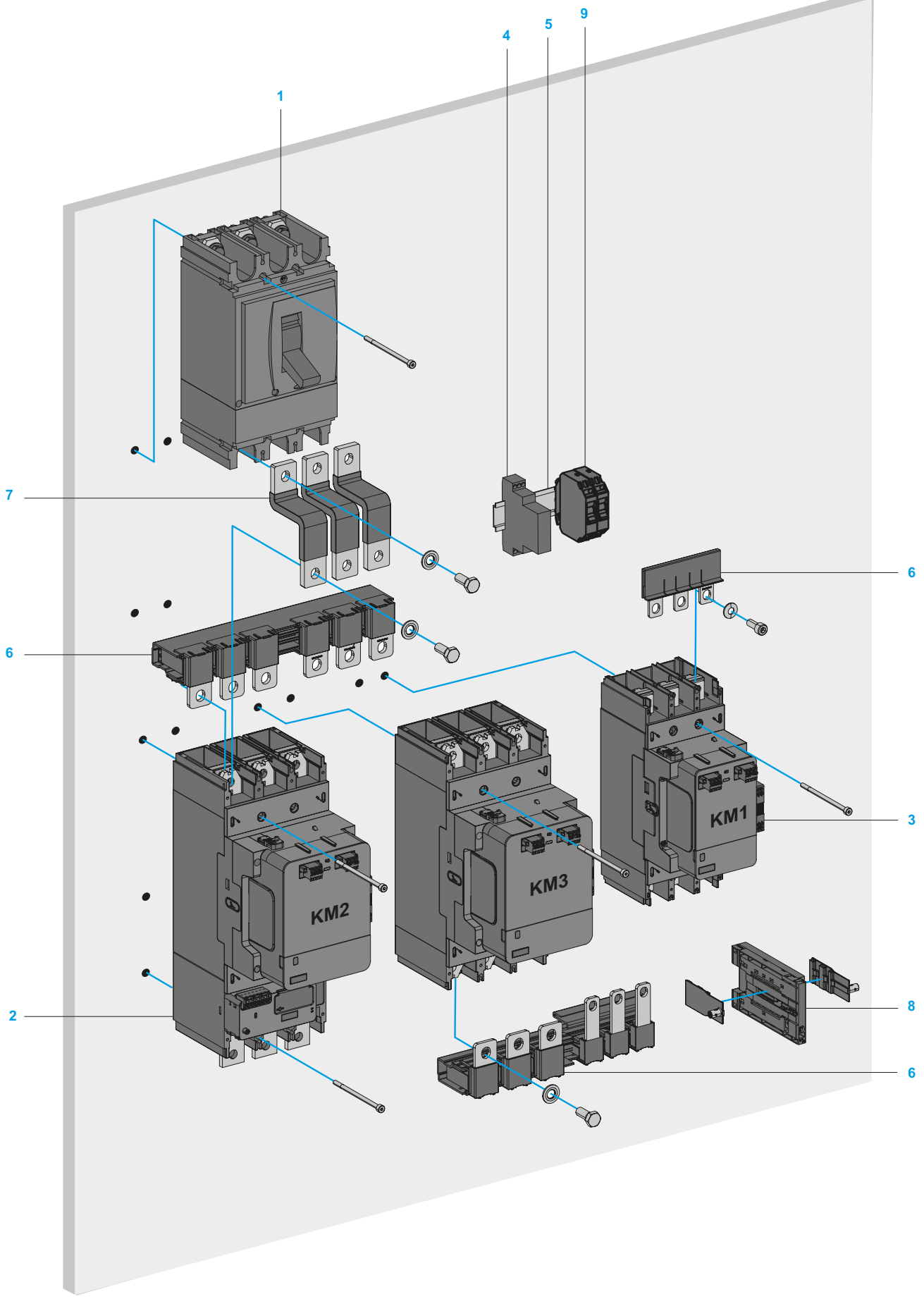

Star-delta starters with mechanical interlock for customer assembly on back-panel

Maximum operating rate: 30 starts/hour.

Maximum starting time: 30 seconds.

For selection of TeSys Giga Contactors ⁽²⁾, overload relay ⁽³⁾ and circuit breaker ⁽³⁾ at different operating voltages, please refer to coordination tables pages A5/29, A5/38 and A5/39.

For Star-delta 'Power' and 'Control' circuit diagrams, please refer to page A2/26.

Separate components ⁽⁴⁾

Description	Illustration item no.	For use on	No.	Sold in lots of	Unit reference
Circuit breakers	1	G115...G500	1	1	GV5P220...GV6P500
			1	1	NSX250...NSX630
			1	1	NS800...NS1000
Electronic thermal overload relays	2	G115...G500	1	1	LR9G115... LR9G500 ⁽⁴⁾
Auxiliary contact blocks 1NO + 1NC	3	G115...G500	3	-	LAG8N113P (Supplied with the contactor)
Timer	4	G115...G500	1	1	RE17RMMWS
Mounting Rail	5	G115...G500	1	10	NSYSDR200
Sets of power connections	6	G115...G500 (LDY) ⁽⁵⁾	1	1	LA9GQQ330
		G115...G500 (LDY) ⁽⁵⁾	1	1	LA9GSS330
		G115...G500 (LDY) ⁽⁵⁾	1	1	LA9GTT330
		LD: G265...G500 ⁽⁵⁾ Y: G115...G225 ⁽⁵⁾	1	1	LA9GSQ331
Flexible terminal extensions for MCCB	7	G115...G225	1	1	LA9G3111
		G265...G500	1	1	LA9G3112
Mechanical interlock kit	8	G115...G500	1	1	LA9G970
		G265...G500 # G115...G225	1	1	LA9G971
Thermal magnetic circuit breaker for 5 A control circuit	9	G115...G500	2	6	GB2CB10

⁽¹⁾ Protection shall be provided by a thermal-magnetic circuit breaker or by a magnetic circuit breaker and an overload relay combination.

⁽²⁾ The contactors are supplied with wide band AC/DC coils with 1 NO + 1 NC auxiliary contact block. Please refer to pages B9/10 to B9/13 for the complete references of the contactors.

⁽³⁾ The protection device settings should be adjusted according to motor characteristics and conditions of use.

⁽⁴⁾ Please refer to pages B11/11 to B11/14 for details on **LR9G** electronic overload relays.

⁽⁵⁾ L- Line contactor/ D- Delta contactor/ Y- Star contactor.



TeSys Control

Open pre-cabled motor starters

Product references

Open
motor
starters

AB1AB8M35	GV2ME06K1BW3	LC3D09AB7
AB1AB8P35	GV2ME06K2BW3	LC3D09AP7
AB1BC15035	GV2ME06K2M7	LC3D115F7A64
AB1BC9535	GV2ME07K1BW3	LC3D115M7A64
ACMGV1084	GV2ME07K2BW3	LC3D115P7
ACMGV763	GV2ME08K1BW3	LC3D115P7A64
ACMGV973	GV2ME08K1P7	LC3D120AP7
AE3FX122	GV2ME10K1BW3	LC3D12AB7
AF1CD061	GV2ME14K1B7	LC3D12AP7
AF1CD081	GV2MP01	LC3D150M7A64
AF1VA410	GV2MP02	LC3D150P7
AF1VA618	GV2MP03	LC3D150P7A64
AF1VC820	GV2MP04	LC3D180AB7
AM3PA65	LA9D11517	LC3D180AP7
CAD32	LA9D115604	LC3D18AB7
GB2CB05	LA9D115692	LC3D18AF7
GB2CB10	LA9D11570	LC3D18AP7
GK2AX50	LA9D115704	LC3D18AU7
GV2AF01	LA9D12974	LC3D320AG7
GV2AF3	LA9D15017	LC3D320AP7
GV2AF4	LA9D5017	LC3D32AB7
GV2DM102BD	LA9D730	LC3D32AF7
GV2DM107BD	LA9D80973	LC3D32AP7
GV2DM107P7	LA9D901	LC3D80B7
GV2DM108B7	LA9GQQ330	LC3D80B7A64
GV2DM108BD	LA9GSS330	LC3D80E7A64
GV2DM108P7	LA9GTT330	LC3D80F7
GV2DM110BD	LA9GSQ331	LC3D80F7A64
GV2DM114B7	LA9G3111	LC3D80M7
GV2DM114BD	LA9G3112	LC3D80P7
GV2DM116BD	LA9G970	LC3D80P7A64
GV2DM132B7	LA9G971	LC3D80U7A64
GV2DM204B7	LAD31	LC3K09P7
GV2DM205BD	LAD91217	LC4D12AP7
GV2DM206BD	LAD91218	LC4D12AV7
GV2DM208BD	LAD93217	LC4D25AB7
GV2DM221M7	LAD93219	LC4D25AP7
GV2DM221P7	LADN10	NSYDPR25
GV2DM232P7	LADN22	NSYSNM6
GV2MC01	LADT2	NSYSNM8
GV2MC02	LAG8N113P	NSYSDR200
GV2MC03	LC3D090AB7	RE17RMMWS
GV2MCK04	LC3D090AP7	

This document is current.  Click on the product reference to get the most recent availability status (hyperlink to [se.com](https://www.se.com) product datasheet).
If your product variant is no longer available, please consult your distributor or regional sales office.

Technical Data for Designers

Contents

Non-reversing / Reversing starters A2/18 to A2/21

Star-delta starters A2/22 to A2/26

TeSys Control

Open pre-cabled motor starters

Dimensions, mounting

Open motor starters

GV2ME●●K●●

On mounting rail NSYSDR200

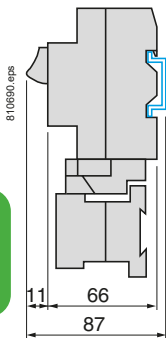

GV2ME●●K1●●

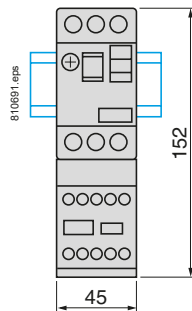

GV2ME●●K2●●

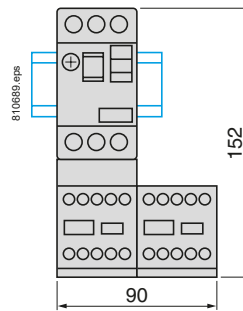

GV2DM●●●●

On mounting rail NSYSDR200

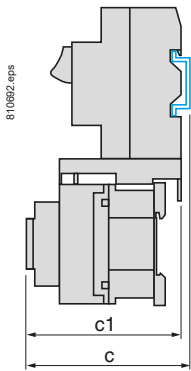

GV2DM1●●●●

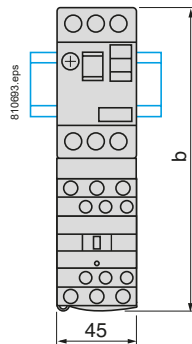

GV2DM2●●●●

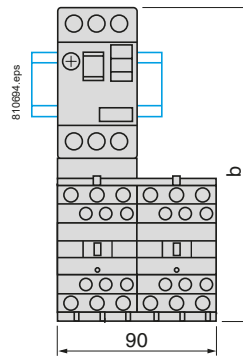

Ref.
⚡

GV2DM●●●● contactor with AC or DC coil on mounting rail NSYSDR200

GV2	DM●02●● to DM●20●●	DM●21●● to DM●32●●
b	177	187
c	106	113
c1	96	103

GV2P●● + LC●D09 + GV2AF3

On mounting rail NSYSDR200

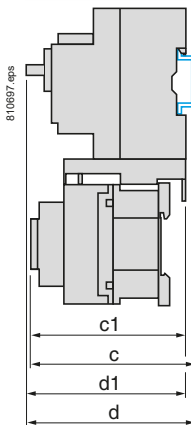

GV2P●● + LC1D●● + GV2AF3

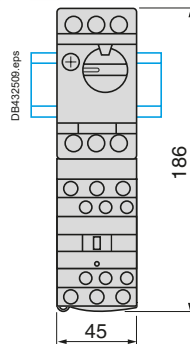

GV2P●● + LC2D●●●● + GV2AF3

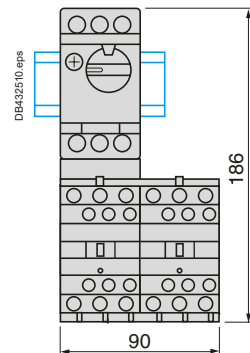

LC1D, LC2D contactor with AC or DC coil on mounting rail

GV2	P02 to P08	P10 to P32
c	111	118
c1	101	108
d	107	107
d1	97	97

TeSys Control

Open pre-cabled motor starters

Dimensions, mounting

GV3P●●1 + LC1D40A...D65A (for customer assembly)

Vertical mounting ⁽¹⁾

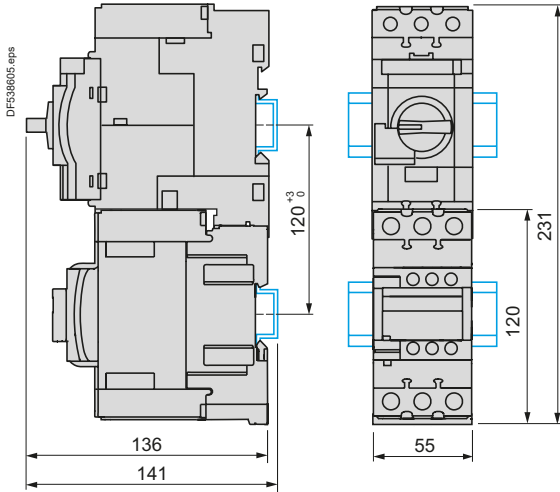

Side by side mounting with S-shape busbar system GV3 S ⁽²⁾

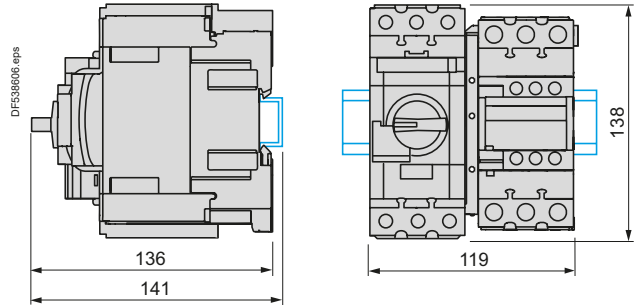

GV3P●●1 + LC2D40A...D65A (for customer assembly)

Vertical mounting ⁽¹⁾

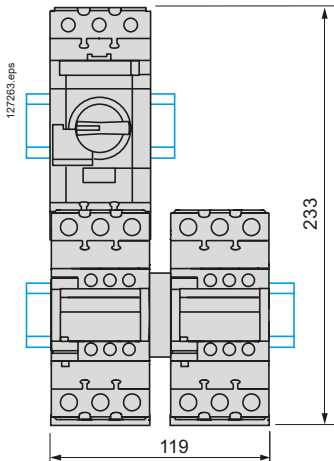

Side by side mounting with S-shape busbar system GV3 S ⁽²⁾

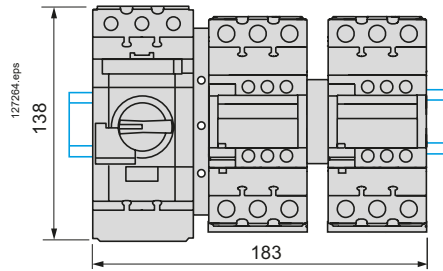

- (1) For several side-by-side motor starters, the maximum current allowed is equal to the nominal current under 400 V.
 Example: 55 A for a 30 kW motor under 400 V, for a GV3 P65 circuit breaker and a LC1 D65A contactor association.
- (2) The maximum current allowed is equal to 90 % of maximum current. Example: 45 A for a LC1 D50A contactor.

Open
motor
starters

Ref.



TeSys Control

Open pre-cabled motor starters

Schemes

Open motor starters

GV2ME●●K1●●

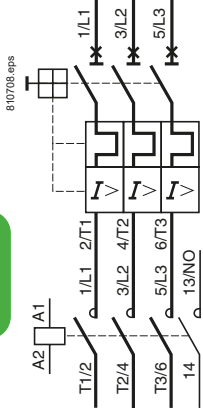

GV2ME●●K2●●

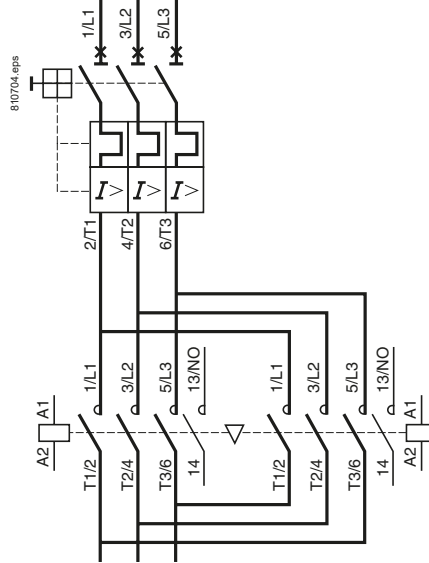

Ref.

GV2DM1●●●●

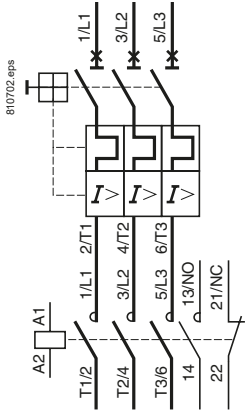

GV2DM2●●●●

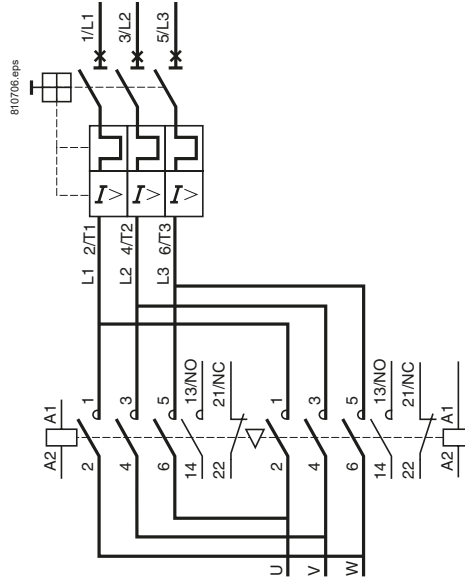

TeSys Control

Open pre-cabled motor starters

Schemes

GV2P●● + LC1D●●●●

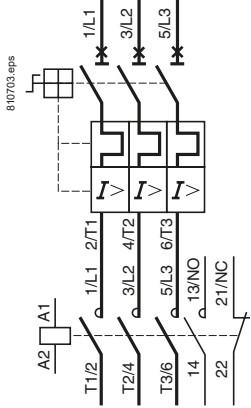

GV2P●● + LC2D●●●●

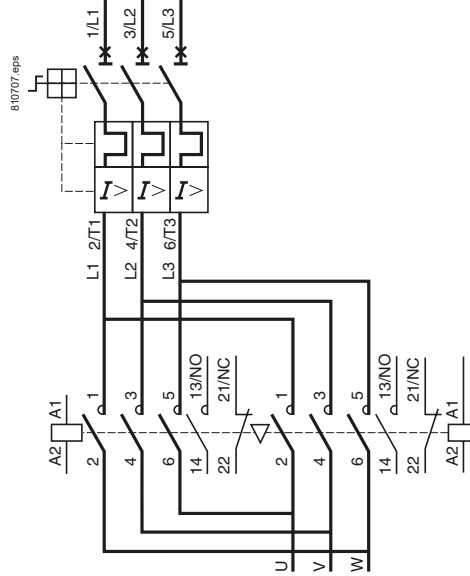

Mechanical interlock with integral electrical contacts

Control circuit ~

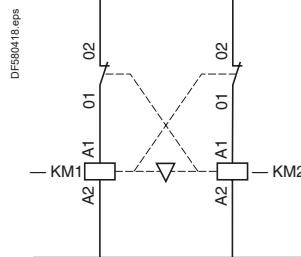
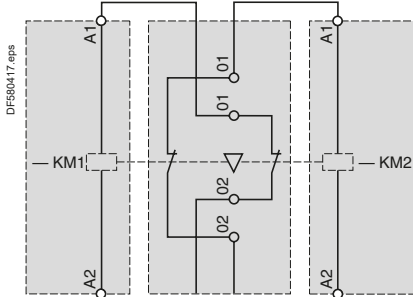

Control circuit ⋯

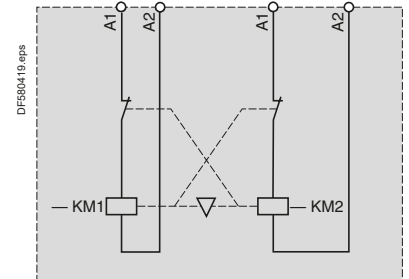

Open
motor
starters

Ref.





Star-delta starting

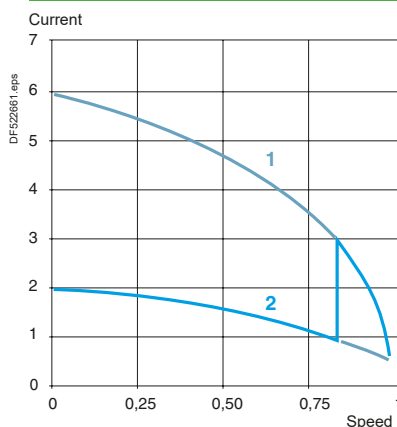

- 1 Starting in direct delta connection
- 2 Starting in star connection

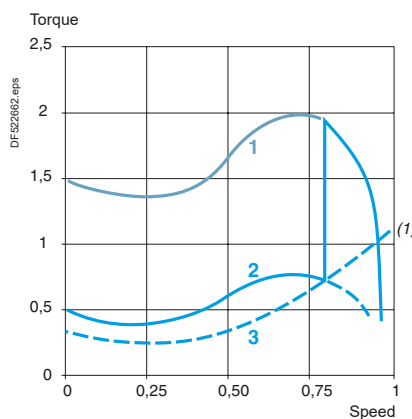

- 1 Starting in direct delta connection
- 2 Starting in star connection
- 3 Resistive torque of the machine

This method of starting is applicable to motors on which all 6 stator terminals are accessible and whose delta connection voltage corresponds to the mains voltage.

Star-delta starting should be used for motors starting on no-load or having a low load torque and gradual build-up:

- the starting torque in star connection is reduced to one third of the direct starting torque, i.e. about 50 % of the rated torque.
- the starting current in star connection is about 1.8 to 2.6 times the rated current.

The transition from star to delta connection must occur when the machine has run up to speed. A too rapid build-up in load torque would cause the stabilised run-up speed to be too low and would therefore eliminate any advantage in this method of starting: this is the case with certain machines whose load torque depends on the machine speed (a characteristic of centrifugal machines, for example).

All star-delta starters are supplied with a special LADS2 or LA2KT2 time delay relay which imposes a delay on the delta contactor during the transition period in order to allow the star contactor sufficient breaking time.

For ratings D115 and D150, this function is performed by a time delay auxiliary contact block LADT2 and a control relay.

(1) Motor manufacturers generally specify machine load torques.
Example: maximum resistive torque on completion of star-delta start (expressed as a proportion of the rated torque).

TeSys Control

Star-delta starters

Dimensions, mounting

Dimensions

LC3K plate mounted, pre-assembled

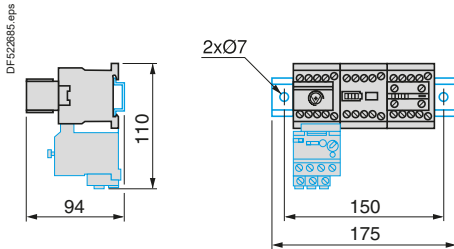

On starters LC3D09A to D18A, a connection block is mounted on the upper part of contactor KM2, increasing the overall height of the product by 6.5 mm.

LC3D09A...D32A pre-assembled or 3 x LC1D09A...D32A (customer assembly) + components

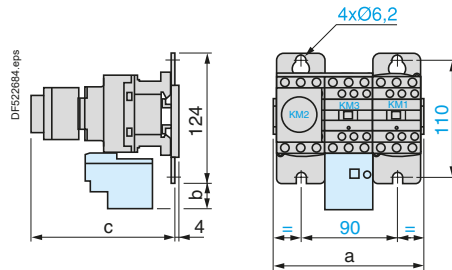

LC3	D09A	D12A	D18A	D32A
a	143	143	144	165
b	26.5	26.5	26.5	32.5
c	with LADS	139	139	145
	with LADS and sealing cover	143	143	149

LC3D80 pre-assembled or 3 x LC1D80 (customer assembly) + components

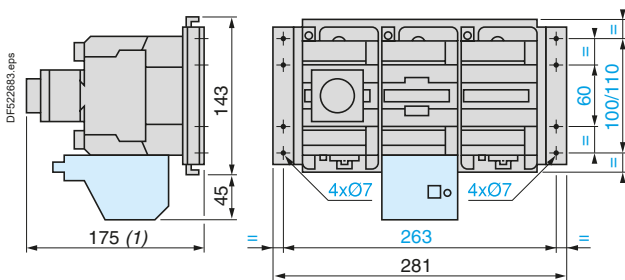

(1) +4 mm with sealing cover

LC3D115, D150 pre-assembled or 3 x LC1D115...D150 (customer assembly) + components

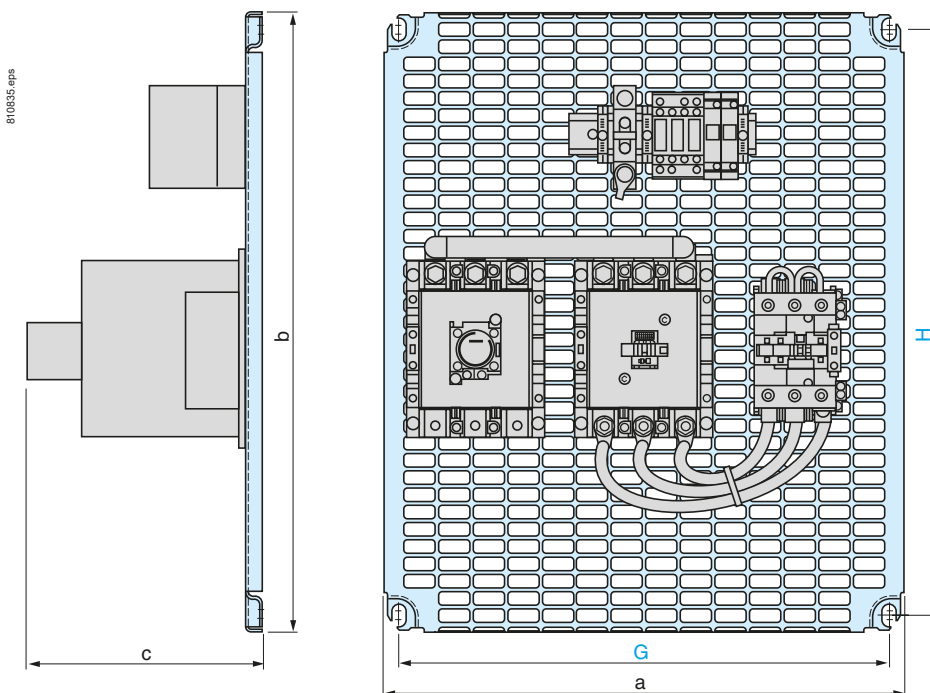

		a	b	c	G	H	
LC3D115 or 3 x LC1D	with components	D115	450	555	205	425	525
LC3D150 or 3 x LC1D	with components	D150	450	555	205	425	525

References:
pages A2/8 to A2/13

Introduction:
page A2/22

Schemes:
page A2/24

TeSys Control

Star-delta starters

Dimensions, mounting, schemes

Dimensions

LC3D090A à D320A on NSYS DR mounting rail, pre-assembled

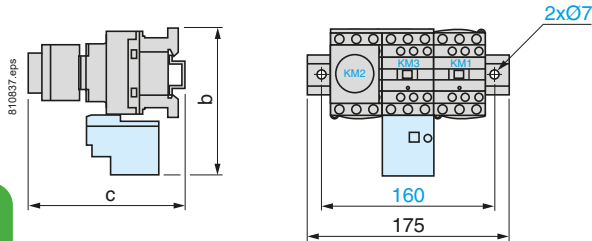

LC3	D090A à D180A	D320A
b	153	137
c	with LADS	145
	with LADS and sealing cover	149

Schemes

LC3K, LC3D09A to D80
LC3D090A to D320A

LC3K

LC3D

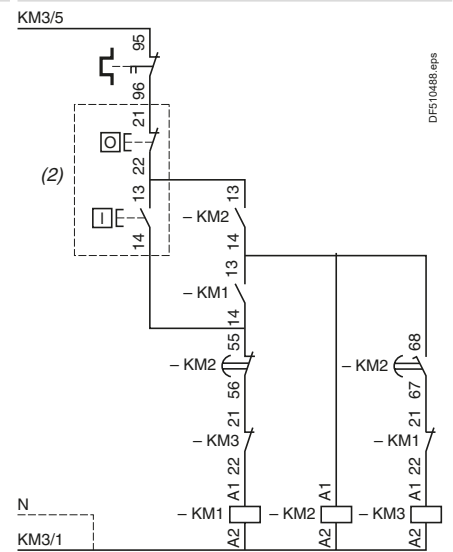
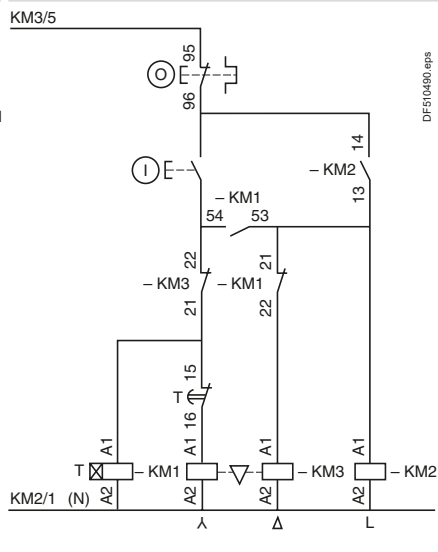
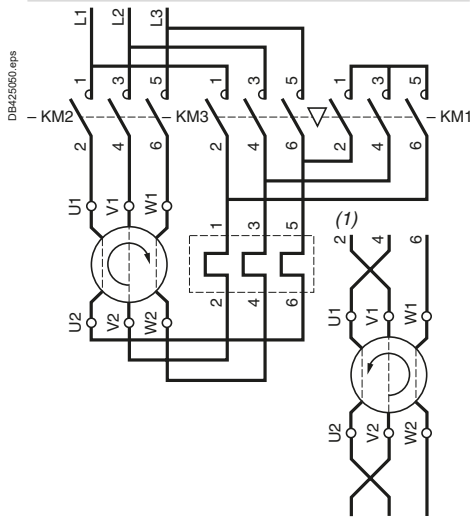

Note: LC3D09A to D18A: Mechanical interlock between KM3 and KM1.

LC3D115 and D150

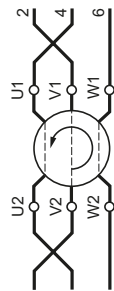
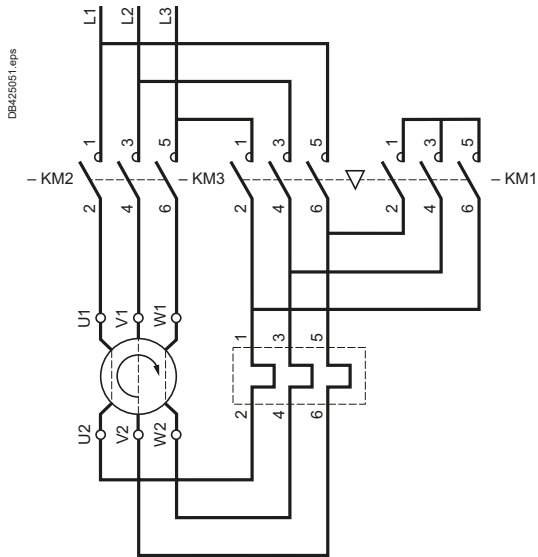

Recommended cabling for reversal of motor rotation (standard motor, viewed from shaft end).

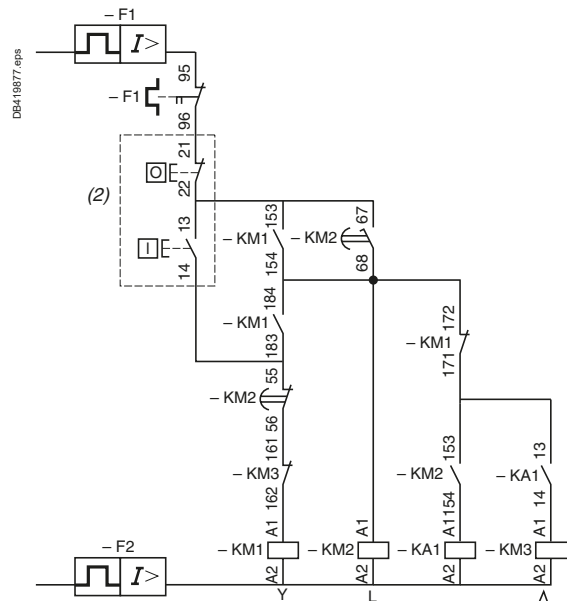

(1) Recommended cabling for reversal of motor rotation (standard motor, viewed from shaft end).

(2) Remote control.

TeSys Control

Star-delta starters

Dimensions, mounting

Dimensions

TeSys Giga star-delta starters with mechanical interlock for customer assembly on back-panel

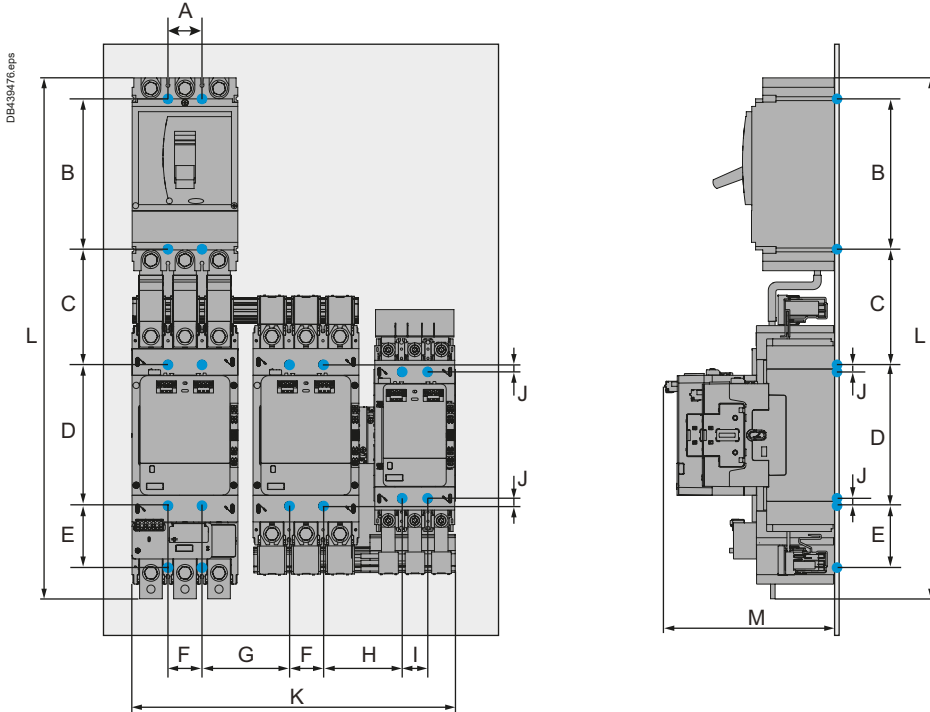

Circuit Breaker	Line & Delta Contactor	Star Contactor	Overload relay											Overall width	Overall height	Overall depth
				A	B	C	D	E	F	G	H	I	J			
NSX250	LC1G115 ...225	LC1G115 ...225	LR9G115/ LR9G225	35	125	87	166	79.15	35	92.7	92.7	35	0	364	523	193
NSX400/ NSX630	LC1G115 ...225	LC1G115 ...225	LR9G115/ LR9G225	45	200	118	166	79.15	35	92.7	92.7	35	0	364	565.5	193
NSX400/ NSX630	LC1G265 ...500	LC1G115 ...225	LR9G500	45	200	118	187	81.85	45	115	103.85	35	10.5	428	670	225
NSX400/ NSX630	LC1G265 ...500	LC1G265 ...500	LR9G500	45	200	118	187	81.85	45	115	115	45	0	463	670	225
NS800	LC1G265 ...500	LC1G115 ...225	LR9G500	199	200	217	187	81.85	45	115	103.85	35	10.5	428	804.6	225
NS800	LC1G265 ...500	LC1G265 ...500	LR9G500	199	200	217	187	81.85	45	115	115	45	0	463	804.6	225

Note: All dimensions are in mm.

Open motor starters

Ref.

i

+

TeSys Control

Star-delta starters

Schemes

Open motor starters

Ref.
i
↕

TeSys Giga star-delta motor 'Power' circuit diagram

Thermal magnetic circuit breaker + contactors

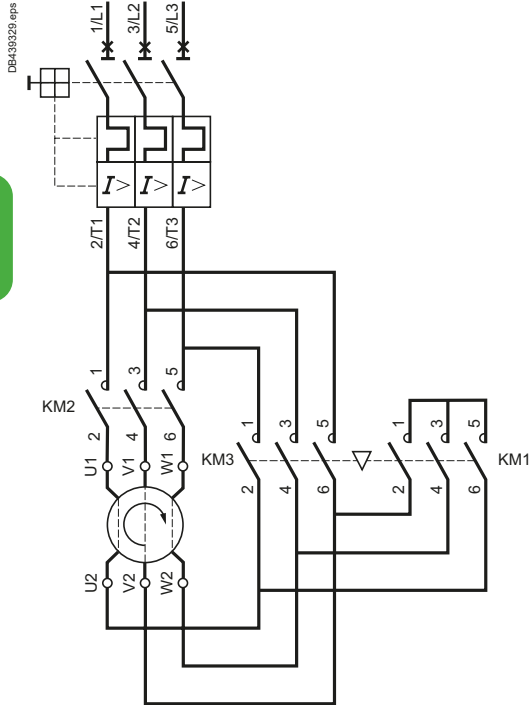

Magnetic circuit breaker + contactors + overload relay

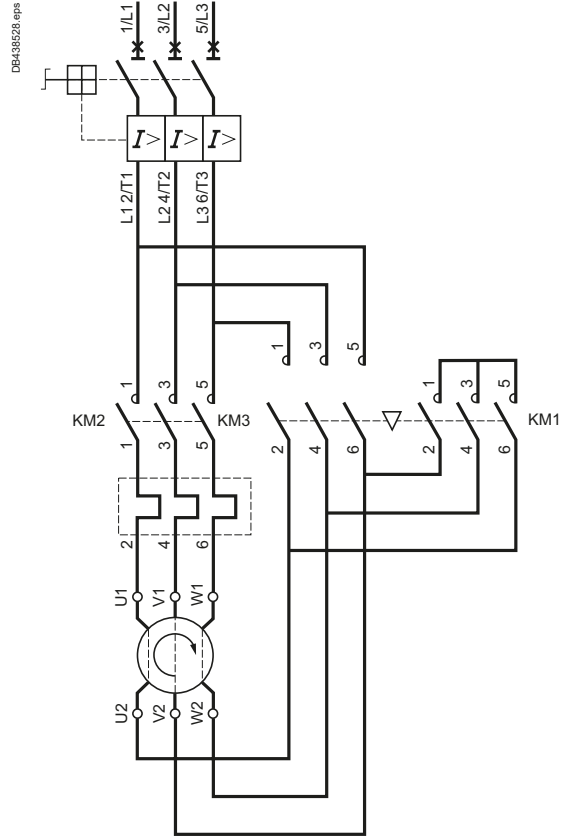

TeSys Giga star-delta motor 'Control' circuit diagram

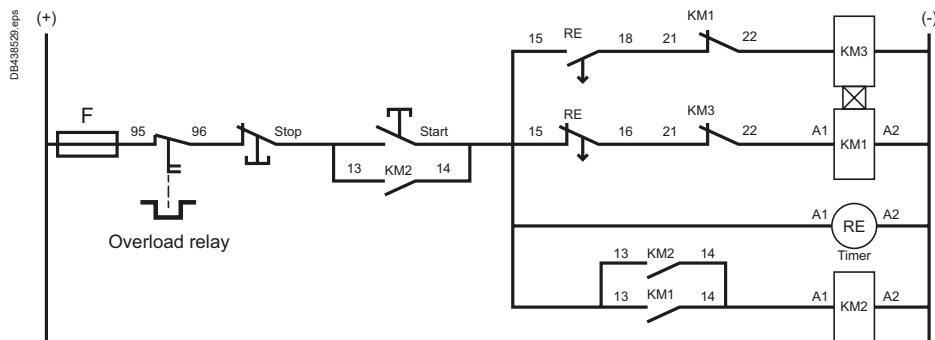

Recommended timing relay (RE): Zelio Timer ref. **RE17RMMWS** (12...240 V AC/DC 50/60 Hz – 8 AAC/DC contacts)