

Modicon Edge I/O NTS

Network Interface Modules

User Guide

Original instructions

EIO0000004794.00

12/2024

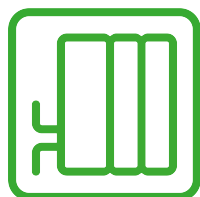

Legal Information

The information provided in this document contains general descriptions, technical characteristics and/or recommendations related to products/solutions.

This document is not intended as a substitute for a detailed study or operational and site-specific development or schematic plan. It is not to be used for determining suitability or reliability of the products/solutions for specific user applications. It is the duty of any such user to perform or have any professional expert of its choice (integrator, specifier or the like) perform the appropriate and comprehensive risk analysis, evaluation and testing of the products/solutions with respect to the relevant specific application or use thereof.

The Schneider Electric brand and any trademarks of Schneider Electric SE and its subsidiaries referred to in this document are the property of Schneider Electric SE or its subsidiaries. All other brands may be trademarks of their respective owner.

This document and its content are protected under applicable copyright laws and provided for informative use only. No part of this document may be reproduced or transmitted in any form or by any means (electronic, mechanical, photocopying, recording, or otherwise), for any purpose, without the prior written permission of Schneider Electric.

Schneider Electric does not grant any right or license for commercial use of the document or its content, except for a non-exclusive and personal license to consult it on an "as is" basis.

Schneider Electric reserves the right to make changes or updates with respect to or in the content of this document or the format thereof, at any time without notice.

To the extent permitted by applicable law, no responsibility or liability is assumed by Schneider Electric and its subsidiaries for any errors or omissions in the informational content of this document, as well as any non-intended use or misuse of the content thereof.

Table of Contents

Safety Information	4
Before You Begin	4
Start-up and Test	5
Operation and Adjustments	6
About the Book	7
Modicon Edge I/O NTS General Description	11
Overview	12
Modicon Edge I/O NTS Network Interface Modules	13
Ethernet Network Interface Modules	14
NTSNEC1200/NTSNEC1200H Network Interface Module, EtherNet/IP, Modbus TCP, 100 Mbps, 2 RJ45, Standard/Hardened	15
NTSNEC1200/NTSNEC1200H Presentation	15
Overview	15
Main Characteristics	15
Purchasing Information	16
Physical Description	18
Status LEDs	19
NTSNEC1200/NTSNEC1200H Characteristics	21
Overview	21
Dimensions	22
Weight	23
General Characteristics	24
Rotary Switch	25
Overview	25
Setting an IP Address	26
Applying the IP Address	27
Cybersecurity Switch	28
Ethernet Port	29
Overview	29
Characteristics	29
Pin Assignment	29
Status LEDs	30
Communication Cables and Connectors	30
Connecting the Network Interface Module to a PC	31
USB Port CN1 Connection	31
USB Port CN1 Characteristics	32
Configuring the Virtual Ethernet Link	32
Ethernet Port Connection	33
Ethernet Network Interface Modules Configuration	34
Memory Mapping	35
Appendices	36
Data Exchange	37
Data Exchange Principle	37
Modbus TCP Data Exchange	38
EtherNet/IP Data Exchange	41
Modbus TCP Explicit Exchange	46
Index	47

Safety Information

Important Information

Read these instructions carefully, and look at the equipment to become familiar with the device before trying to install, operate, service, or maintain it. The following special messages may appear throughout this documentation or on the equipment to warn of potential hazards or to call attention to information that clarifies or simplifies a procedure.



The addition of this symbol to a “Danger” or “Warning” safety label indicates that an electrical hazard exists which will result in personal injury if the instructions are not followed.



This is the safety alert symbol. It is used to alert you to potential personal injury hazards. Obey all safety messages that follow this symbol to avoid possible injury or death.

DANGER

DANGER indicates a hazardous situation which, if not avoided, **will result in** death or serious injury.

WARNING

WARNING indicates a hazardous situation which, if not avoided, **could result in** death or serious injury.

CAUTION

CAUTION indicates a hazardous situation which, if not avoided, **could result in** minor or moderate injury.

NOTICE

NOTICE is used to address practices not related to physical injury.

Please Note

Electrical equipment should be installed, operated, serviced, and maintained only by qualified personnel. No responsibility is assumed by Schneider Electric for any consequences arising out of the use of this material.

A qualified person is one who has skills and knowledge related to the construction and operation of electrical equipment and its installation, and has received safety training to recognize and avoid the hazards involved.

Before You Begin

Do not use this product on machinery lacking effective point-of-operation guarding. Lack of effective point-of-operation guarding on a machine can result in serious injury to the operator of that machine.

▲ WARNING
<p>UNGUARDED EQUIPMENT</p> <ul style="list-style-type: none"> • Do not use this software and related automation equipment on equipment which does not have point-of-operation protection. • Do not reach into machinery during operation. <p>Failure to follow these instructions can result in death, serious injury, or equipment damage.</p>

This automation equipment and related software is used to control a variety of industrial processes. The type or model of automation equipment suitable for each application will vary depending on factors such as the control function required, degree of protection required, production methods, unusual conditions, government regulations, etc. In some applications, more than one processor may be required, as when backup redundancy is needed.

Only you, the user, machine builder or system integrator can be aware of all the conditions and factors present during setup, operation, and maintenance of the machine and, therefore, can determine the automation equipment and the related safeties and interlocks which can be properly used. When selecting automation and control equipment and related software for a particular application, you should refer to the applicable local and national standards and regulations. The National Safety Council's Accident Prevention Manual (nationally recognized in the United States of America) also provides much useful information.

In some applications, such as packaging machinery, additional operator protection such as point-of-operation guarding must be provided. This is necessary if the operator's hands and other parts of the body are free to enter the pinch points or other hazardous areas and serious injury can occur. Software products alone cannot protect an operator from injury. For this reason the software cannot be substituted for or take the place of point-of-operation protection.

Ensure that appropriate safeties and mechanical/electrical interlocks related to point-of-operation protection have been installed and are operational before placing the equipment into service. All interlocks and safeties related to point-of-operation protection must be coordinated with the related automation equipment and software programming.

NOTE: Coordination of safeties and mechanical/electrical interlocks for point-of-operation protection is outside the scope of the Function Block Library, System User Guide, or other implementation referenced in this documentation.

Start-up and Test

Before using electrical control and automation equipment for regular operation after installation, the system should be given a start-up test by qualified personnel to verify correct operation of the equipment. It is important that arrangements for such a check are made and that enough time is allowed to perform complete and satisfactory testing.

▲ WARNING
<p>EQUIPMENT OPERATION HAZARD</p> <ul style="list-style-type: none"> • Verify that all installation and set up procedures have been completed. • Before operational tests are performed, remove all blocks or other temporary holding means used for shipment from all component devices. • Remove tools, meters, and debris from equipment. <p>Failure to follow these instructions can result in death, serious injury, or equipment damage.</p>

Follow all start-up tests recommended in the equipment documentation. Store all equipment documentation for future references.

Software testing must be done in both simulated and real environments.

Verify that the completed system is free from all short circuits and temporary grounds that are not installed according to local regulations (according to the National Electrical Code in the U.S.A, for instance). If high-potential voltage testing is necessary, follow recommendations in equipment documentation to prevent accidental equipment damage.

Before energizing equipment:

- Remove tools, meters, and debris from equipment.
- Close the equipment enclosure door.
- Remove all temporary grounds from incoming power lines.
- Perform all start-up tests recommended by the manufacturer.

Operation and Adjustments

The following precautions are from the NEMA Standards Publication ICS 7.1-1995:

(In case of divergence or contradiction between any translation and the English original, the original text in the English language will prevail.)

- Regardless of the care exercised in the design and manufacture of equipment or in the selection and ratings of components, there are hazards that can be encountered if such equipment is improperly operated.
- It is sometimes possible to misadjust the equipment and thus produce unsatisfactory or unsafe operation. Always use the manufacturer's instructions as a guide for functional adjustments. Personnel who have access to these adjustments should be familiar with the equipment manufacturer's instructions and the machinery used with the electrical equipment.
- Only those operational adjustments required by the operator should be accessible to the operator. Access to other controls should be restricted to prevent unauthorized changes in operating characteristics.

About the Book

Document Scope

This guide describes the implementation of Modicon Edge I/O NTS network interface modules. It provides the description, characteristics, wiring diagrams and configuration details for Modicon Edge I/O NTS network interface modules.

Validity Note

This document has been updated for the release of Modicon Edge I/O NTS network interface modules firmware V1.0.0.

For product compliance and environmental information (RoHS, REACH, PEP, EOL, etc.), go to www.se.com/ww/en/work/support/green-premium/.

The characteristics of the products described in this document are intended to match the characteristics that are available on www.se.com. As part of our corporate strategy for constant improvement, we may revise the content over time to enhance clarity and accuracy. If you see a difference between the characteristics in this document and the characteristics on www.se.com, consider www.se.com to contain the latest information.

Related Documents

Title of documentation	Reference number
Modicon Edge I/O - System Planning and Installation Guide	EIO0000004786 (ENG)
Modicon Edge I/O - Configurator and Web Interface - User Guide	EIO0000004810 (ENG)
Modicon Edge I/O - Software Integration and Compatibility - User Guide	EIO0000004818 (ENG)
Modicon Edge I/O - Diagnostic Data - User Guide	EIO0000004826 (ENG)
Modicon Edge I/O NTS - Discrete Modules - User Guide	EIO0000005238 (ENG)
Modicon Edge I/O NTS - Analog Modules - User Guide	EIO0000005246 (ENG)
Modicon Edge I/O NTS - Counting Modules - User Guide	EIO0000005262 (ENG)

To find documents online, visit the Schneider Electric download center (www.se.com/ww/en/download/).

Product Related Information

DANGER

HAZARD OF ELECTRIC SHOCK, EXPLOSION OR ARC FLASH

- Disconnect all power from all equipment including connected devices prior to removing any covers or doors, or installing or removing any accessories, hardware, cables, or wires except under the specific conditions specified in the appropriate hardware guide for this equipment.
- Always use a properly rated voltage sensing device to confirm the power is off where and when indicated.
- Replace and secure all covers, accessories, hardware, cables, and wires and confirm that a proper ground connection exists before applying power to the unit.
- Use only the specified voltage when operating this equipment and any associated products.

Failure to follow these instructions will result in death or serious injury.

WARNING

LOSS OF CONTROL

- Perform a Failure Mode and Effects Analysis (FMEA), or equivalent risk analysis, of your application, and apply preventive and detective controls before implementation.
- Provide a fallback state for undesired control events or sequences.
- Provide separate or redundant control paths wherever required.
- Supply appropriate parameters, particularly for limits.
- Review the implications of transmission delays and take actions to mitigate them.
- Review the implications of communication link interruptions and take actions to mitigate them.
- Provide independent paths for control functions (for example, emergency stop, over-limit conditions, and error conditions) according to your risk assessment, and applicable codes and regulations.
- Apply local accident prevention and safety regulations and guidelines.¹
- Test each implementation of a system for proper operation before placing it into service.

Failure to follow these instructions can result in death, serious injury, or equipment damage.

¹ For additional information, refer to NEMA ICS 1.1 (latest edition), "Safety Guidelines for the Application, Installation, and Maintenance of Solid State Control" and to NEMA ICS 7.1 (latest edition), "Safety Standards for Construction and Guide for Selection, Installation and Operation of Adjustable-Speed Drive Systems" or their equivalent governing your particular location.

WARNING

UNINTENDED EQUIPMENT OPERATION

- Only use software and hardware components approved by Schneider Electric for use with the system.
- Update your application program every time you change the physical hardware configuration.

Failure to follow these instructions can result in death, serious injury, or equipment damage.

Information on Non-Inclusive or Insensitive Terminology

As a responsible, inclusive company, Schneider Electric is constantly updating its communications and products that contain non-inclusive or insensitive terminology. However, despite these efforts, our content may still contain terms that are deemed inappropriate by some customers.

Terminology Derived from Standards

The technical terms, terminology, symbols and the corresponding descriptions in the information contained herein, or that appear in or on the products themselves, are generally derived from the terms or definitions of international standards.

In the area of functional safety systems, drives and general automation, this may include, but is not limited to, terms such as *safety*, *safety function*, *safe state*, *fault*, *fault reset*, *malfunction*, *failure*, *error*, *error message*, *dangerous*, etc.

Among others, these standards include:

Standard	Description
IEC 61131-2:2007	Programmable controllers, part 2: Equipment requirements and tests.
ISO 13849-1:2023	Safety of machinery: Safety related parts of control systems. General principles for design.
EN 61496-1:2020	Safety of machinery: Electro-sensitive protective equipment. Part 1: General requirements and tests.
ISO 12100:2010	Safety of machinery - General principles for design - Risk assessment and risk reduction
EN 60204-1:2006	Safety of machinery - Electrical equipment of machines - Part 1: General requirements
ISO 14119:2013	Safety of machinery - Interlocking devices associated with guards - Principles for design and selection
ISO 13850:2015	Safety of machinery - Emergency stop - Principles for design
IEC 62061:2021	Safety of machinery - Functional safety of safety-related electrical, electronic, and electronic programmable control systems
IEC 61508-1:2010	Functional safety of electrical/electronic/programmable electronic safety-related systems: General requirements.
IEC 61508-2:2010	Functional safety of electrical/electronic/programmable electronic safety-related systems: Requirements for electrical/electronic/programmable electronic safety-related systems.
IEC 61508-3:2010	Functional safety of electrical/electronic/programmable electronic safety-related systems: Software requirements.
IEC 61784-3:2021	Industrial communication networks - Profiles - Part 3: Functional safety fieldbuses - General rules and profile definitions.
2006/42/EC	Machinery Directive
2014/30/EU	Electromagnetic Compatibility Directive
2014/35/EU	Low Voltage Directive

In addition, terms used in the present document may tangentially be used as they are derived from other standards such as:

Standard	Description
IEC 60034 series	Rotating electrical machines
IEC 61800 series	Adjustable speed electrical power drive systems
IEC 61158 series	Digital data communications for measurement and control – Fieldbus for use in industrial control systems

Finally, the term *zone of operation* may be used in conjunction with the description of specific hazards, and is defined as it is for a *hazard zone* or *danger zone* in the *Machinery Directive (2006/42/EC)* and *ISO 12100:2010*.

NOTE: The aforementioned standards may or may not apply to the specific products cited in the present documentation. For more information concerning the individual standards applicable to the products described herein, see the characteristics tables for those product references.

Modicon Edge I/O NTS General Description

What's in This Part

Overview	12
Modicon Edge I/O NTS Network Interface Modules	13

Overview

The Modicon Edge I/O NTS network interface modules are devices designed to manage EtherNet/IP and Modbus TCP communication in association with I/O modules in a distributed architecture.

Software configuration is accomplished with one of the following options:

- The Edge I/O configuration software (refer to the Modicon Edge I/O Configurator and Web Interface - User Guide).
- The EcoStruxure Automation Expert software (refer to the EcoStruxure Automation Expert online help).
- The EcoStruxure Automation Expert - Motion software (refer to the EcoStruxure Automation Expert - Motion online help).
- The embedded Web interface (refer to the Modicon Edge I/O Configurator and Web Interface - User Guide).

Modicon Edge I/O NTS Network Interface Modules

The following table shows the network interface modules, with their ports, communication protocols, and connection types:

Reference	Port	Communication protocol	Connection type
NTSNEC1200	2 isolated switched Ethernet ports	EtherNet/IP Modbus TCP	RJ45
	1 USB port	USB 2.0	USB Type-C
NTSNEC1200H	2 isolated switched Ethernet ports	EtherNet/IP Modbus TCP	RJ45
	1 USB port	USB 2.0	USB Type-C

Ethernet Network Interface Modules

What's in This Part

NTSNEC1200/NTSNEC1200H Network Interface Module, EtherNet/IP, Modbus TCP, 100 Mbps, 2 RJ45, Standard/Hardened.....	15
---	----

NTSNEC1200/NTSNEC1200H Network Interface Module, EtherNet/IP, Modbus TCP, 100 Mbps, 2 RJ45, Standard/Hardened

What's in This Chapter

NTSNEC1200/NTSNEC1200H Presentation	15
NTSNEC1200/NTSNEC1200H Characteristics	21
Rotary Switch	25
Ethernet Port	29
Connecting the Network Interface Module to a PC	31
Ethernet Network Interface Modules Configuration	34

NTSNEC1200/NTSNEC1200H Presentation

Overview

The NTSNEC1200/NTSNEC1200H network interface modules are devices designed to manage EtherNet/IP or Modbus TCP communication protocol when using I/O modules for the island.

The NTSNEC1200H module is the hardened version (H suffix) of the NTSNEC1200 module (standard version). With conformal coating of the electronic boards, the hardened version of the module can be used in harsh chemical environments and at extended operating temperatures. For more information on environmental characteristics, refer to Modicon Edge I/O - System Planning and Installation Guide.

NOTE: The network interface module is the leftmost module in the main cluster.

Main Characteristics

The following table shows the main characteristics of NTSNEC1200/NTSNEC1200H network interface modules:

Characteristics	Value
Communication protocol	EtherNet/IP, Modbus TCP
Connector type	RJ45, USB Type-C
Rotary switch	3
Ethernet	2 isolated switched Ethernet ports

Purchasing Information

The following figure shows the elements of the Modicon Edge I/O NTS NTSNEC1200 network interface module:

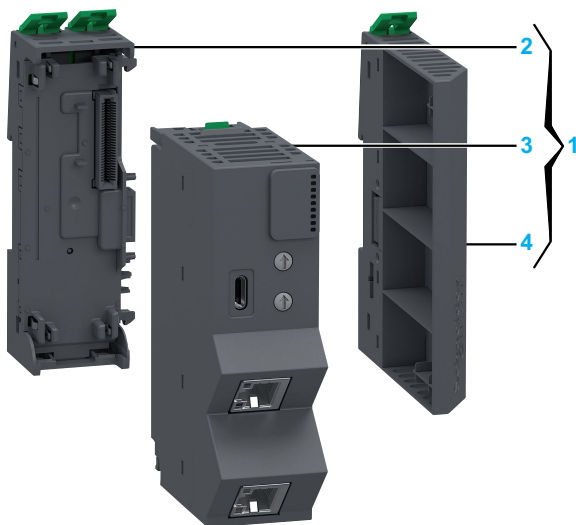

Number	Reference	Description
1	NTSNEC1200K	Base + module + cluster termination (kit) NOTE: The module, its corresponding compatible base and the cluster termination can be purchased as a kit.
2	NTSXBA0201H	Spare Base, 2 Slots, for Network Interface or Bus Extender Module, Hardened
3	NTSNEC1200	Network Interface Module, EtherNet/IP, Modbus TCP, 100 Mbps, 2 RJ45
4	NTSXMP0000H	Spare Cluster Termination, Hardened

The following figure shows the main elements of the Modicon Edge I/O NTS NTSNEC1200H network interface module:

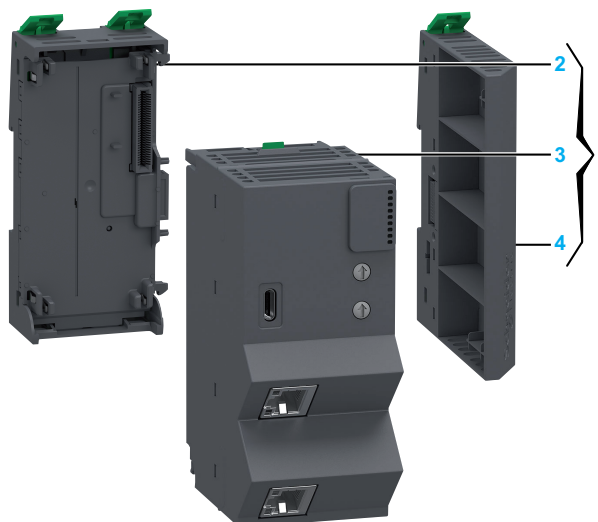

Number	Reference	Description
1	NTSNEC1200HK	Base + module + cluster termination (kit) NOTE: The module, its corresponding compatible base and the cluster termination can be purchased as a kit.
2	NTSXBA0301H	Spare Base, 3 Slots, for Network Interface Module, Hardened
3	NTSNEC1200H	Network Interface Module, EtherNet/IP, Modbus TCP, 100 Mbps, 2 RJ45, Hardened
4	NTSXMP0000H	Spare Cluster Termination, Hardened

NOTE: For more information on accessories and spare parts, refer to Modicon Edge I/O - System Planning and Installation Guide.

Physical Description

The following figures show the elements of the network interface modules:

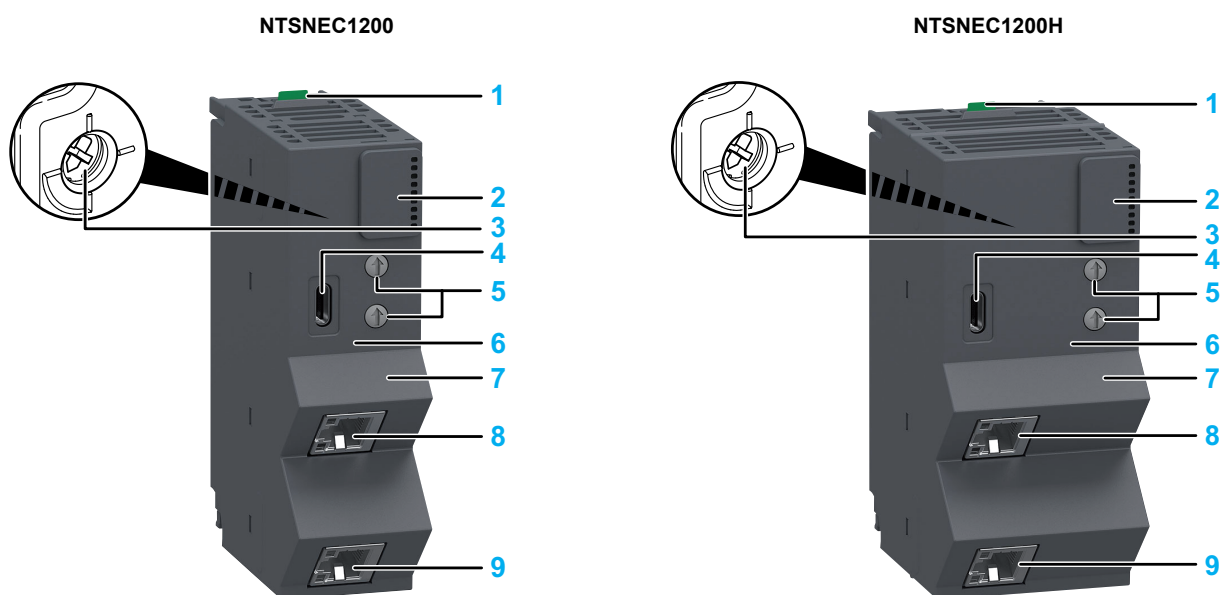

1 Release button: Use the release button to remove the module from the base.

2 Status LEDs: Indicate the status of the module.

3 Cybersecurity rotary selector switch: Use this rotary switch to set the Cybersecurity mode.

4 USB Type-C port (CN1): Use this port to configure and upgrade firmware of the island.

5 Rotary switches: Use the upper/lower rotary switch to manage the the IP address of network interface module.

6 MAC address: This unique 48-bit network ID is hard-coded in the module when manufactured.

7 Space provided for user labeling.

8 Ethernet port 1 (CN2): Use this RJ45 port to connect the network interface module to the fieldbus Ethernet network.

9 Ethernet port 2 (CN3): Use this RJ45 port to connect the network interface module to the fieldbus Ethernet network.

Status LEDs

The following figure shows the network interface module status LEDs:

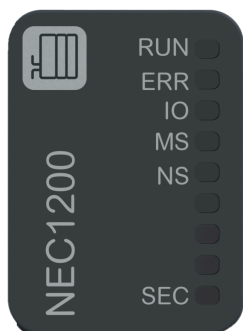

The following table describes the status LEDs during the module initialization mode:

RUN	ERR	IO	MS	NS	SEC	Description
OFF	Red ON	OFF	OFF	OFF	OFF	Indicates the first initialization step: power supply initialization.
OFF	Red Regular Flash	OFF	Red Regular Flash	OFF	OFF	Indicates the second initialization step: network interface modules Boot-up.
OFF	OFF	OFF	OFF	OFF	OFF	Indicates the third initialization step: all LEDs OFF.
OFF	OFF	OFF	Green ON	Green ON	OFF	Indicates the fourth initialization step: MS and NS LEDs green ON for 250 ms.
OFF	OFF	OFF	Red ON	Red ON	OFF	Indicates the fifth initialization step: MS and NS LEDs red ON for 250 ms.
OFF	OFF	OFF	OFF	OFF	OFF	Indicates the sixth initialization step: all LEDs OFF for 250 ms.
Green ON	Red ON	Green ON	Green ON	Green ON	Green ON	Indicates the seventh initialization step: all LEDs ON.
OFF	OFF	OFF	OFF	Green ON	OFF	Indicates that a reboot is needed for new IP address assignment.
Green Regular Flash	OFF	OFF	Red ON	Red ON	Green Regular Flash	Indicates that the factory reset is in progress.
Green ON	OFF	OFF	Red ON	Red ON	Green ON	Indicates that the factory reset is completed.
OFF	Red Regular Flash	OFF	Green Regular Flash	OFF	-	Indicates that no IP address is entered and no configuration is received.
OFF	Red Regular Flash	OFF	Green Regular Flash	Green Regular Flash	-	Indicates that a valid IP address is entered but no configuration is received. ⁽¹⁾
-	-	-	Green Regular Flash	-	-	Indicates that no IP address is entered and configuration is received.
-	-	-	Green ON	-	-	Indicates that a valid IP address is entered and configuration is received. ⁽¹⁾
Green Regular Flash	OFF	OFF	Red ON	Red ON	-	Indicates that the firmware is being updated.
Green Regular Flash	Red Regular Flash	Orange Regular Flash	Orange Regular Flash	Orange Regular Flash	Orange Regular Flash	Indicates that the device identification is ongoing.
OFF	Red ON	OFF	OFF	OFF	Red ON	Indicates that the advanced mode position is detected but not supported.

⁽¹⁾ A valid IP address means a configured IP address (from configuration, from a DHCP or from a BOOT server).

The following table describes the status LEDs during the module configuration mode and IO data communication establishment:

RUN	ERR	IO	MS	NS	SEC	Description
Green Regular Flash	OFF	-	-	Green Regular Flash	-	Indicates that no communication with the controller is established.
Green ON	OFF	-	-	Green ON	-	Indicates that the communication with the controller is established.
-	-	Green ON	-	-	-	Indicates that the IOBUS data exchange is ongoing.
-	-	-	-	-	Orange Regular Flash	Indicates that no internal unsecured connection is established (BusSec disabled).
-	-	-	-	-	Orange ON	Indicates that an internal unsecured connection is established (BusSec disabled).

The following table describes the status LEDs during the error detection operating mode:

RUN	ERR	IO	MS	NS	SEC	Description
-	-	-	Red Regular Flash	-	-	Indicates that a position change occurs on rotary switch during operation mode. ⁽¹⁾
OFF	Red ON	OFF	Red ON	OFF	OFF	Indicates that the power manager unit is in power down mode. ⁽¹⁾
-	-	-	-	Red Regular Flash	-	Indicates that the controller connection has timed out. ⁽²⁾
OFF	Red ON	OFF	Red ON	OFF	Red ON	Indicates a non recoverable detected error.
-	-	-	Red Regular Flash	Red ON	-	Indicates a Fallback duplicate IP. ⁽¹⁾
-	-	Red ON	-	-	-	Indicates that at least one I/O module or Extender module in the island is in error. ⁽¹⁾
-	-	Red Regular Flash	-	-	-	Indicates discrepancies between the configuration and missing or incorrect modules. ⁽¹⁾
-	-	-	-	-	Red Regular Flash	Indicates that a Cybersecurity error is detected.

⁽¹⁾ This detected error indicator takes precedence over the actual state, except for all initialization states.

⁽²⁾ It is only applicable for EtherNet/IP communication protocol.

The following graphic shows the system status of LEDs during module operation:

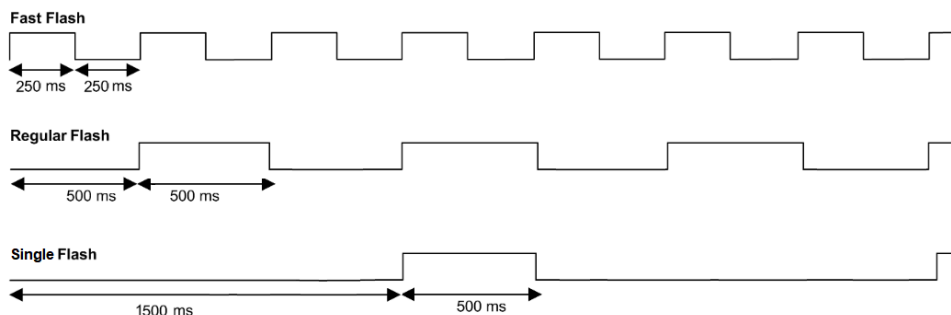

NOTE: For more information on the activities and connectivity of each associated LED of the Ethernet port, refer to Status LEDs, page 30.

NTSNEC1200/NTSNEC1200H Characteristics

Overview

This section provides a general description of the characteristics of the module.

⚠ WARNING

UNINTENDED EQUIPMENT OPERATION

Do not exceed any of the rated values specified in the environmental and electrical characteristics tables.

Failure to follow these instructions can result in death, serious injury, or equipment damage.

For more information on environmental characteristics, refer to Modicon Edge I/O - System Planning and Installation Guide.

Dimensions

The following figure shows the external dimensions of the assembled NTSNEC1200 network interface modules:

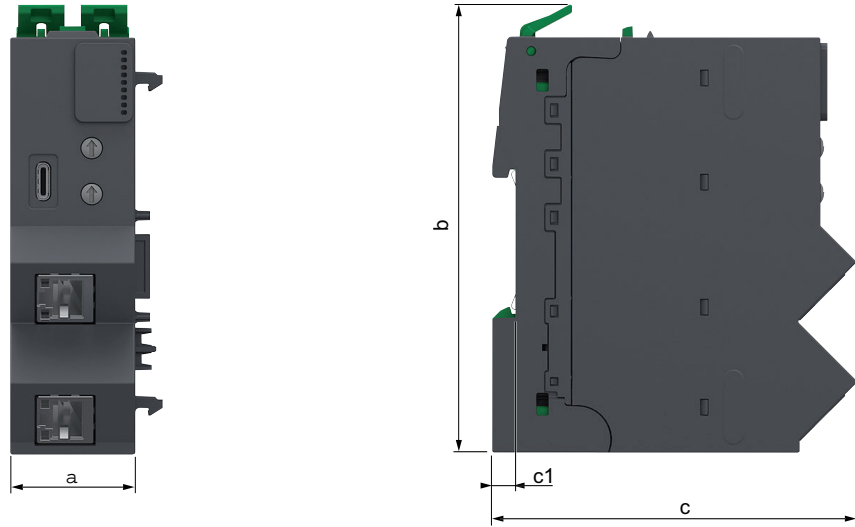

- a:** 30 mm (1.18 in)
- b:** 108.6 mm (4.28 in)
- c:** 87.8 mm (3.46 in)
- c1:** 5.6 mm (0.22 in)

The following figure shows the external dimensions of the assembled NTSNEC1200H network interface modules:

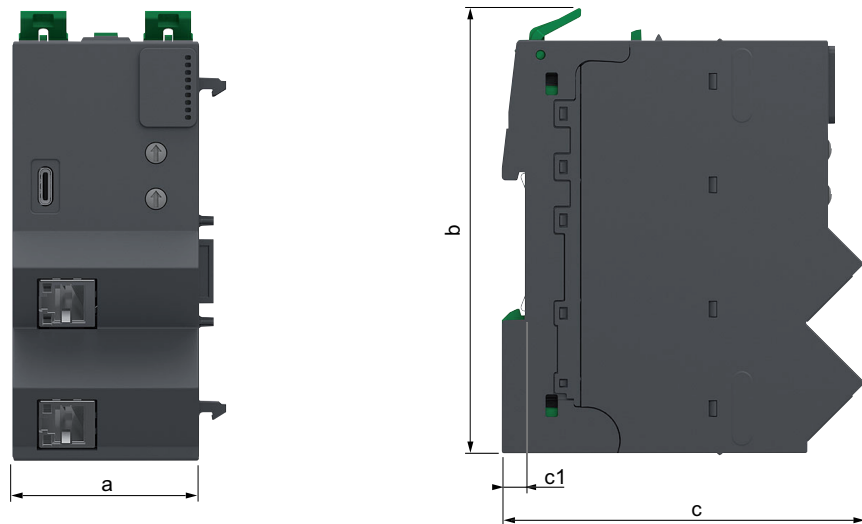

- a:** 45 mm (1.77 in)
- b:** 108.6 mm (4.28 in)
- c:** 87.8 mm (3.46 in)
- c1:** 5.6 mm (0.22 in)

Weight

- NTSNEC1200: 262 g (9.24 oz)
- NTSNEC1200K: 331 g (11.68 oz)
- NTSNEC1200H: 309 g (10.90 oz)
- NTSNEC1200HK: 388 g (13.69 oz)

General Characteristics

The following table describes the general characteristics of the module:

Characteristics		Value
Rated supplied voltage		24 Vdc
Power supplied voltage range		20.4...28.8 Vdc
Internal current consumption		140 mA at 24 Vdc
Internal isolation		1500 Vac between power supply and Ethernet ports
Power dissipation		3.46 W
Communication performances	Communication port protocol	EtherNet/IP Modbus TCP
	Number of Modbus TCP connections	Up to 8
	Number of EtherNet/IP connections	Up to 8
	Exchange mode	full duplex autonegotiation
	Transmission rate	10/100 Mbit/s
	Topology	Daisy chain Star Ring
	Baud rate	Supports Ethernet "10BaseT", "100BaseT"
	Field bus protocol	EtherNet/IP (adapter) Modbus TCP (server)
	Communication features	<ul style="list-style-type: none"> • IPV4 • USB RNDIS • Web Interface (HTTPs) • DPWS • FDR Client • BootP • DHCP Client • RSTP • NTP V4
	MAC address	<ul style="list-style-type: none"> • Base MAC address for the module internal switch • Base MAC address +1 for local (RNDIS) USB MAC address • Base MAC address +2 for remote (RNDIS) USB MAC address • Base MAC address +3 for front port RJ45 number 1 (CN2) • Base MAC address +4 for front port RJ45 number 2 (CN3)
Supported addressable modules	Per cluster	32 modules including field power supply modules
Interface and connectors	Ethernet	2 RJ45 female connectors isolated, switched Ethernet ports
	Wire type	CAT5 STP shielded twisted pair cables
	USB for a local connection to the module	USB Type-C

Rotary Switch

Overview

The two rotary switches located on the front panel of the Ethernet network interface module are used to set an IP address. Coming out from factory, a network interface module uses the DHCP addressing method by default.

The default positions of the rotary switches are:

- 0 for **TENS x**
- 0 for **ONES y**

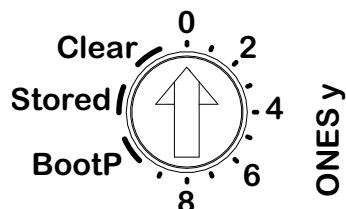
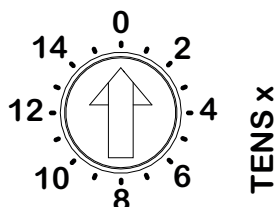

NOTE: You can also set the IP address using the Modicon Edge I/O NTS - Web Interface. The Modicon Edge I/O NTS - Web Interface configured IP address is taken into account when the **ONES y** rotary switch is in the **Stored** position.

Setting an IP Address

Set the rotary switches before:

- Applying power to the module.
- Downloading the configuration.

NOTE: Any modification of the rotary switch position after power up is not taken into account until the next power up.

This table describes the configuration of the rotary switches:

Position of the rotary switches		Description
TENS x	ONES y	
0...15	0...9	<p>Sets the network interface module to DHCP for this range. Allows you to configure the device name. This device name is used to obtain an IP address from a DHCP server or an FDR server. Use both switches to select a numeric value from 0...159 for EtherNet/IP and Modbus TCP.</p> <p>The DHCP name is in DeviceName_TensOnes format.</p> <p>For example, if TENS x = 14 and ONES y = 3, the DHCP name is NTSNEC1200_143 to which the DHCP server assigns an IP address.</p>
Any	BootP	Uses the MAC address to request the IP parameters.
Any	Stored	<p>The default IP address (10.10.MAC5.MAC6) is used. The last two fields (MAC5 and MAC6) in the default IP address are the last two hexadecimal bytes of the MAC address of the port.</p> <p>You can modify the network configuration with the embedded Modicon Edge I/O NTS - Web Interface.</p> <p>NOTE: A MAC address is always written in hexadecimal format and an IP address in decimal format. Convert the MAC address to decimal format. For example, if the MAC address is 00.80.F4.01.80.F2, the default IP address is 10.10.128.242.</p>
Any	Clear	<p>Allows you to clear the module IP parameters and the stored island configuration.</p> <p>The Cybersecurity configuration however remains.</p> <p>This option is useful if a stored IP address had been configured. Once power is cycled in this position, the module will no longer communicate. Therefore, it is necessary that another addressing method is thereafter selected and power again cycled to re-establish communications with the NIM.</p>

Carefully manage the IP addresses because each device on the network requires a unique address. Having multiple devices with the same IP address can cause unintended operation of your network and associated equipment.

⚠ WARNING
<p>UNINTENDED EQUIPMENT OPERATION</p> <ul style="list-style-type: none"> • Verify that there is only one master controller configured on the network or remote link. • Verify that all devices have unique addresses. • Obtain your IP address from your system administrator. • Confirm that the IP address of the device is unique before placing the system into service. • Do not assign the same IP address to any other equipment on the network. • Update the IP address after cloning any application that includes Ethernet communications to a unique address. <p>Failure to follow these instructions can result in death, serious injury, or equipment damage.</p>

It is good practice to ensure that your system administrator maintains a record of all assigned IP addresses on the network and subnetwork, and to inform the system administrator of all configuration changes performed.

Applying the IP Address

The device reads the position of the rotary switches at power up.

If communication is not established, verify that the position of the rotary switches is correct. You must do a power cycle to apply the new address setting.

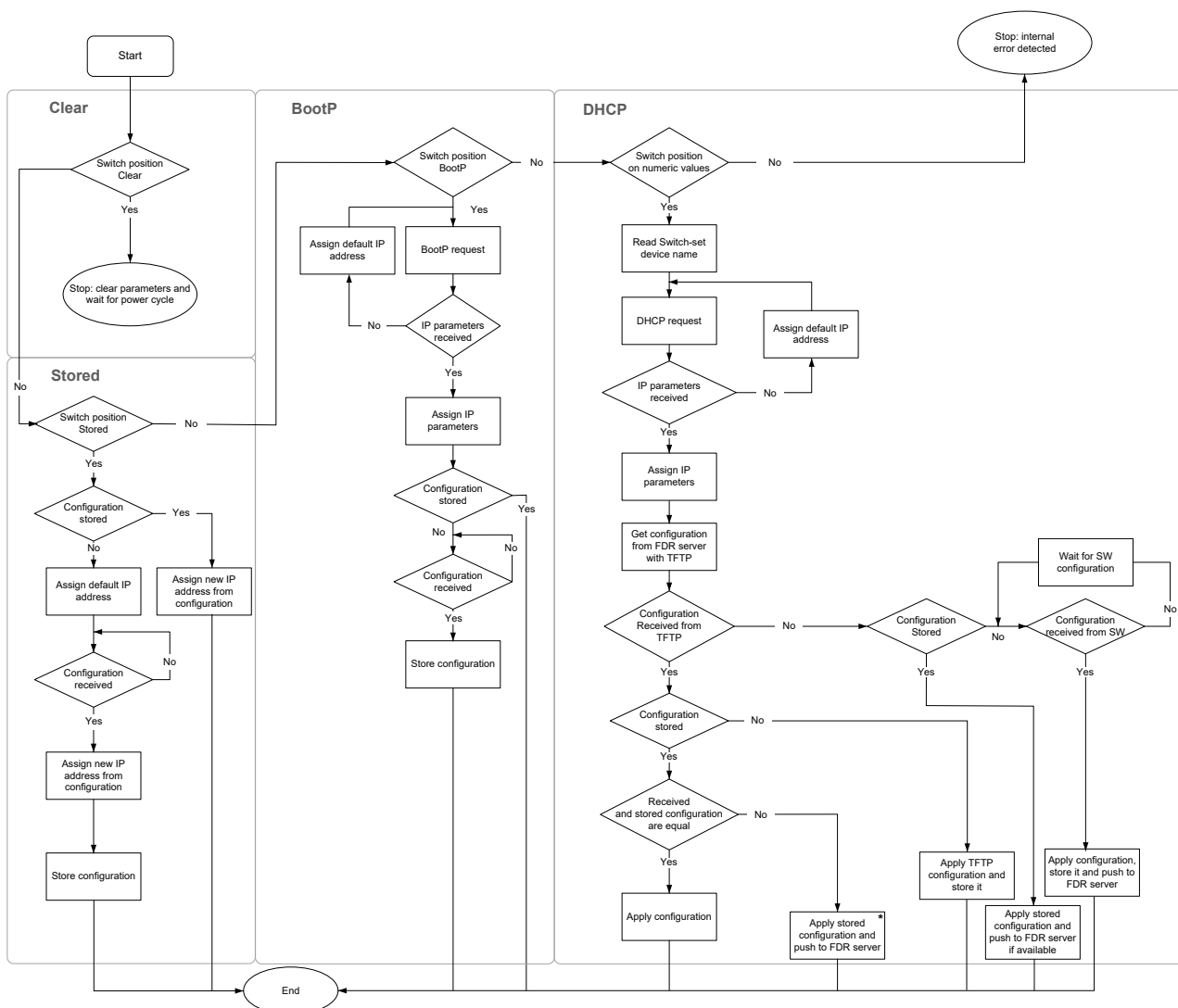

* For a device replacement with FDR, reset the replacement device to factory settings before applying power to the cluster.

When the EtherNet communication is interrupted, the NIM performs new DHCP/BootP requests to reconfigure the IP address. The store mode can be used to reduce the recovery time.

Cybersecurity Switch

A four-position rotary selector switch for Cybersecurity is located on the back of the module. To set up the rotary selector switch position, remove the module from the base. For more information on module removal, refer to Modicon Edge I/O - System Planning and Installation Guide.

NOTICE

RISK OF UNINTENDED OPERATION

Use only a small, plastic screwdriver to change the rotary switch position. Using a metal screwdriver can damage the switch, rendering it inoperable.

Failure to follow these instructions can result in equipment damage.

The four positions of the Cybersecurity switch are the following:

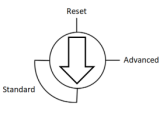
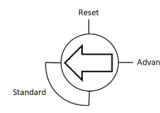
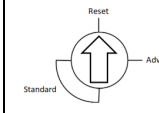
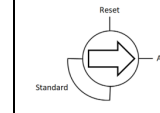
Rotary selector position				
Cybersecurity mode	Standard (default mode)		Reset	Advanced*
* Advanced mode is not supported for this release. Selecting this mode leads to a locked state with specific status LEDs.				

For more information on each Cybersecurity mode, refer to Modicon Edge I/O Configurator and Web Interface User Guide.

- **Standard mode:** The standard mode is selected by positioning the Cybersecurity rotary switch to the down or left position.
- **Reset mode:** The reset mode is selected by positioning the Cybersecurity rotary switch to the up position. When selected, it is indicated at the next power up of the network interface module that the device has been reset to factory settings through the LEDs panel as defined in Status LEDs section.
- **Advanced mode:** Not supported.

Ethernet Port

Overview

The network interface module is equipped with two isolated switched Ethernet ports (**CN2**, **CN3**).

Characteristics

The following table describes the Ethernet characteristics:

Characteristic	Description
Protocol	Modbus TCP, EtherNet/IP
Connector type	RJ45
Auto-negotiation	Yes
Automatic cross-over detection	Yes
Topology	Daisy-chain, star, ring (using RSTP)

Pin Assignment

This graphic shows the RJ45 Ethernet connector pin assignment:

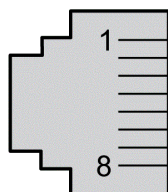

The following table describes the RJ45 Ethernet connector pins:

Pin N°	Signal
1	TX+
2	TX-
3	RX+
4	Reserved
5	Reserved
6	RX-
7	Reserved
8	Reserved

NOTE: The module supports the MDI/MDIX auto-crossover cable function. It is not necessary to use special Ethernet crossover cables to connect devices directly to this port.

Status LEDs

This graphic shows the RJ45 connectors status LEDs:

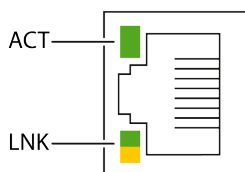

This table describes the Ethernet status LEDs:

Label	Description	LED		
		Color	Status	Description
ACT	Ethernet activity	Green	OFF	No activity
			ON	The link is detected, but there is no activity
			Flashing	Transmitting or receiving data
LNK	Ethernet link/speed	Green/Yellow	OFF	No link
			Yellow ON	Link at 10 Mbit/s
			Green ON	Link at 100 Mbit/s

Communication Cables and Connectors

The communication cables are STP (Shielded Twisted Pair) CAT5 electrical cables with shielded RJ45 connectors. The following table describes the CAT5 cables to connect the network interface modules to an Ethernet network:

Standard	Description	Maximum length	Application	Data rate	Connectors to the Fieldbus Interface
10Base-T	24-gauge, twisted pair	100 m (328 ft)	Data transmission	10 Mbit/s	8-pin male
100Base-TX				100 Mbit/s	

Connecting the Network Interface Module to a PC

USB Port CN1 Connection

The USB Port connection is suitable for short duration connections for the express purposes of configuration, maintenance, and trouble-shooting. It is not intended as a long-standing connection for other purposes. Further, the network interface module may only be connected to a PC.

The following illustration shows the USB connection to a PC:

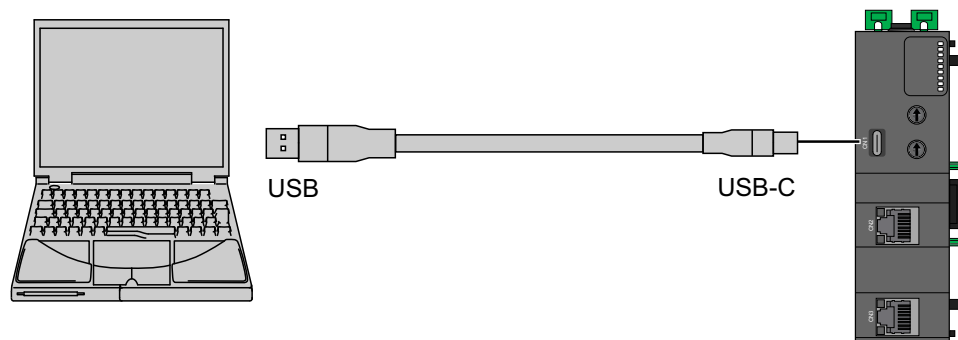

The communication cable should be connected to the PC first to minimize the possibility of electrostatic discharge affecting the network interface module.

<i>NOTICE</i>	
INOPERABLE EQUIPMENT	
Always connect the communication cable to the PC before connecting it to the network interface module.	
Failure to follow these instructions can result in equipment damage.	

To connect the network interface module to the PC, do the following:

Step	Action
1	Connect your USB cable to the PC.
2	Connect the connector of your USB cable to the network interface module USB Type-C connector (CN1). NOTE: A USB Virtual Ethernet Link must be configured on your PC to connect to the network interface module.

<i>NOTICE</i>	
INOPERABLE EQUIPMENT	
<ul style="list-style-type: none"> Always connect directly a PC to the USB port of the network interface module without any intervening device such as a USB port concentrator or hub. The USB connection is only compatible with a maximum nominal voltage of 5 V between connected devices. The connection time must not exceed the time necessary to perform configuration, maintenance, and trouble-shooting. 	
Failure to follow these instructions can result in equipment damage.	

USB Port CN1 Characteristics

The following table describes the characteristics of the USB port:

Characteristic		Description
Connector type		USB Type-C
Isolation		Not isolated
Function		Compatible with USB 2.0
Supported protocol		<ul style="list-style-type: none"> • HTTPS • RNDIS • DPWS
Baud rate		Maximum 480 Mbits
Cable	Length	Maximum 5 m (16.5 ft)
	Type	Shielded

NOTICE

INOPERABLE EQUIPMENT

Do not exceed the maximum cable length of 5 m (16.5 ft) for the USB cable.

Failure to follow these instructions can result in equipment damage.

Configuring the Virtual Ethernet Link

You must configure a virtual Ethernet Link on your USB port, before you can access the network interface module through USB.

To configure a virtual Ethernet Link, configure an Ethernet interface of the USB-RNDIS by following these steps:

Step	Action
1	Remove power from the network interface module.
2	Connect the USB cable to the PC and then to the network interface module.
3	Apply power to the network interface module.
4	Open Network and sharing center on your PC.
5	Click Change adapter settings > Remote NDIS Compatible Device > Properties .
6	Select Internet Protocol version 4 (TCP/IPv4) .
7	Click Properties .
8	Select Use the following IP address to set the USB IP address of your PC. For example: <ul style="list-style-type: none"> • IP address: 192.168.200.2 • Subnet mask: 255.255.255.0
9	Click OK .
10	Close the Properties .
11	In a web browser, enter the USB IP address of your network interface module, by default 192.168.200.1. Result: The Modicon Edge I/O NTS Web Interface is displayed.

Ethernet Port Connection

The following illustration shows the network interface module connection to a PC using the Ethernet ports:

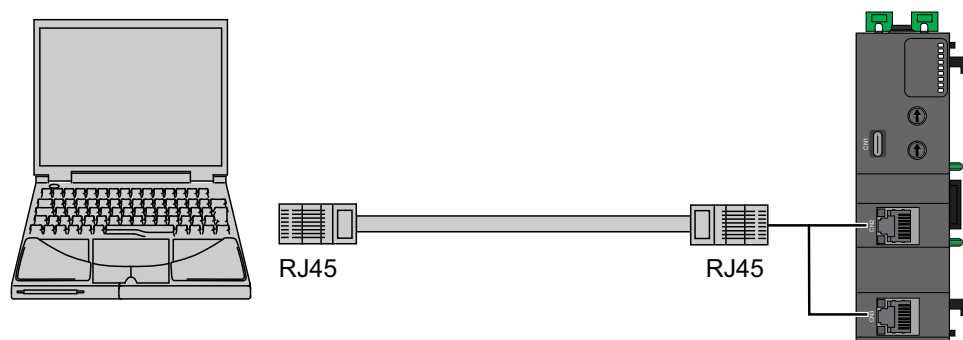

To connect the network interface module to the PC, do the following:

Step	Action
1	Connect the Ethernet cable to the PC.
2	Connect the Ethernet cable to one of the Ethernet ports on the network interface module. NOTE: Your PC and your network interface module must be on the same network and use the same subnet mask.

The default IP address is 10.10.MAC5.MAC6. The last two fields (MAC5 and MAC6) in the default IP address are the last two hexadecimal bytes of the MAC address of the port.

The default subnet mask is 255.255.0.0.

Ethernet Network Interface Modules Configuration

Configurable Parameters

For each Ethernet network interface module, you can configure the following parameters:

Displayed Name <i>Parameter Name</i>	Value(s)	Data Type	Description
NIM IP Address <i>IPConfIPAddress</i>	0.0.0.0*	BYTE	NIM IP Address - only for stored IP mode. For more information, refer to Setting an IP Address, page 26.
NIM IP Subnet Mask <i>IPConfSubnetMask</i>	0.0.0.0*	BYTE	NIM IP Subnet Mask - only for stored IP mode. NOTE: The device can communicate only on its subnetwork when there is no gateway.
NIM IP Gateway Address <i>IPConfGateway</i>	0.0.0.0*	BYTE	Gateway address - only for stored IP mode.
Implicit Communication Protocol <i>Protocol</i>	EtherNet/IP Modbus TCP*	ENUM	Protocol used for implicit exchanges with the controller.
IO Profile <i>IOProfile</i>	Standard* Optimized	ENUM	In standard mode, all implicit data are sent. Some parameters are not part of the implicit data when the optimized I/O profile is selected.
Reset via EIP <i>ResetViaEIP</i>	FALSE* TRUE	BOOL	Enables/Disables reset command over EtherNet/IP.
Communication Hold-up time <i>HoldupTime</i>	0...120000 ms 1000 ms*	UINT	Hold-up time for EtherNet/IP and Modbus TCP. When the communication is interrupted for longer than the configured communication hold-up time, the output values are set to their corresponding fallback values.
NTP primary server IP <i>PrimaryNTPServerIPAddress</i>	0.0.0.0*	BYTE	NTP primary server IP address.
NTP secondary server IP <i>SecondaryNTPServerIPAd- dress</i>	0.0.0.0*	BYTE	NTP secondary server IP address.
RSTP Bridge Identifier Priority <i>RSTPBridgeIdentifierPriority</i>	0...61440 32768*	UINT	RSTP bridge identifier priority. The value must be 0, or set in increments of 4096. Valid values are: 4096, 8192, 12288, 16384, 20480, 24576,...,61440.
IO Bus Cycle Time <i>CycleTime</i>	1 ms 2 ms 4 ms 6 ms 8 ms 10 ms* 100 ms	ENUM	Internal I/O bus exchange cycle time.
VLAN QoS status <i>VlanTag</i>	FALSE* TRUE	BOOL	Enables/Disables VLAN QoS for RIO network.
USB IP address <i>USBIPAddress</i>	192.168.200.1*	IP Address	Configures USB IP address.
USB Subnet Mask <i>USBSubnetMask</i>	255.255.255.0*	IP Address	Configures USB Subnet Mask.
* Parameter default value			

Implicit Data

The following table shows the input implicit data:

<i>Parameter Name</i>	<i>Value</i>	<i>Data Type</i> <i>Size in bytes</i>	<i>Description</i>
<i>Cluster_status</i>	–	BYTE 4	Status of Cluster (1bit/cluster).
<i>NIM_GCS</i>	0...255	BYTE 1	Group Cyclic Status Bit 0: Data quality Bit 1: General module status Bit 2: I/O status Bit 3: N/A Bit 4: N/A Bit 5: Advisory status Bit 6: N/A Bit 7: Data freshness
<i>Embedded_BusExtender_GCS</i>	0...255	BYTE 1	Embedded Bus Extender Group Cyclic Status Bit 0: Data quality Bit 1: General module status Bit 2: N/A Bit 3: N/A Bit 4: N/A Bit 5: Advisory status Bit 6: N/A Bit 7: Data freshness

The following table shows the output implicit data:

<i>Parameter Name</i>	<i>Value</i>	<i>Data Type</i> <i>Size in bytes</i>	<i>Description</i>
<i>Island_Commands</i>	0...65535	BYTE 2	Bit field: Bit 15: Edge I/O fallback value NOTE: Bits 0 to 14 are reserved.

NOTE: You can also configure your module using the FDR server. The configured IP address is taken into account when the rotary switch is in the **DHCP** position. These settings are saved in the FDR server and the non-volatile memory.

Memory Mapping

Memory mapping defines the arrangement and structure of input and output images for implicit input and output exchanges.

When you add an I/O module to the Island, the configurable parameters are displayed in the **PARAMETERS** tab of the I/O module. However, the implicit parameters of the I/O module can be found under the **MEMORY MAPPING** tab of the network interface module.

For more information about implicit and explicit I/O data exchanges, refer to *Data Exchange*, page 37.

Appendices

What's in This Part

Data Exchange	37
---------------------	----

Data Exchange

What's in This Chapter

Data Exchange Principle.....37
 Modbus TCP Explicit Exchange.....46

Overview

The assembly or data object groups different attributes from a variety of application objects into a single attribute that can be moved using a single message. This message provides the I/O data and status of the Modicon Edge I/O NTS network interface module. Assemblies or data objects can be used to bind input data or output data, as defined from the network perspective.

An I/O exchange could be made up of multiple connections. Every connection is dedicated to a part of the I/O image.

An input produces data on the network and an output consumes data from the network.

Data Exchange Principle

Island Reference

The following table describes the referenced Island used to present the data exchange principle in the following sections:

Location (Cluster: Slot)	Product Reference	Data Process Image				Description
		Input		Output		
		Offset (Word)	Length (Byte)	Offset (Word)	Length (Byte)	
–	–	0	4	–	–	I/O Island Cluster Status
–	–	–	–	0	2	I/O Island Output command
0:0	NTSNEC1200	5	1	–	–	Network Interface Module, EtherNet/IP, Modbus TCP, 100 Mbps, 2 RJ45
0:1	NTSDAI0215H	7	3	–	–	Discrete Input Module, 2 Isolated Inputs, 100...240 Vac, 1-/2-/3-wire, Hardened
0:2	NTSDAO0205	10	2	2	1	Discrete Output Module, 2 Outputs, 1 A, 100...240 Vac, 1-/2-/3-wire
0:3	NTSACI0802X	12	20	–	–	Analog Input Module, 8 Inputs, Current, 1-/2-wire, Loop Power
0:4	NTSAHO0212H	30	62	3	4	Analog Output Module, 2 Isolated Outputs, Current, HART, Hardened
0:5	NTSFMB0120	46	226	7	20	Field Device Master Module, Serial, Modbus RTU, ASCII, Client, 115 Kbps with: <ul style="list-style-type: none"> Fieldbus Device 0: 64 bytes IN and 20 bytes OUT Fieldbus Device 1: 124 bytes IN and 0 bytes OUT
<p>NOTE: In the Modicon Edge I/O Configurator software and the embedded Modicon Edge I/O NTS Web Interface, modules are identified by their Device Name.</p>						

Modbus TCP Data Exchange

Overview

Data exchange between a Modbus TCP device and the network interface module is conducted through the Ethernet port on the network interface module.

The Modicon Edge I/O NTS network interface module exchanges data stored in the process image with the Ethernet network using Modbus over TCP/IP.

Initially, data from the Ethernet host is written to the output data image area within the network interface module process image. Subsequently, status, echo output, and input data information from the I/O modules on the island are placed in the input data image area. In this location, the Modbus client can access the data over the TCP/IP network.

The data within the output and input areas of the process image is organized based on the order in which the I/O modules are assembled on the island bus. At startup, the data is sent to the outputs after the complete I/O image has been written.

Two blocks of registers in the data image of the island are involved in I/O data exchanges as shown in the table below:

Registers (MW)			Description
Start	End	Size (Words)	
0	5390	5391	Output range ⁽¹⁾
5391	25279	19888	Input range ⁽²⁾
<p>⁽¹⁾ Output registers are write-only range registers.</p> <p>⁽²⁾ To read into the island input image registers, the Modbus request must fit the registers range assigned to one or more modules, or the whole island input image.</p>			

Input Data Process Image

Input data and I/O status information from the I/O modules are sent to the input process image area and start at register 5391.

The input data starts with the cluster error status bits followed by the network interface module Group Cyclic Status (GCS only in cluster 0), and the cluster 0 Extender module Group Cyclic Status in register 5393.

Each bit of the cluster error status bits indicates, for each cluster, whether an error is detected (1 if no error is detected, 0 if an error is detected). For each cluster, the status bit is zero if any of the modules in the island has a zero in the bits 0, 1, 2, or 4 of the I/O module Group Cyclic Status. The network interface module Group Cyclic Status (cluster 0) or Extender module Group Cyclic Status (clusters 1-24) is included in the derivation of the cluster error status bit for each cluster.

The I/O modules are represented in the input process image area. Their assigned registers start at register 5394 and continue in the order of their island bus addresses.

Discrete I/O modules use two adjacent registers:

- Discrete input modules use one register to report data and the next to report status.
- Discrete output modules use one register to report echo output data and the next to report health.

Analog input modules use four adjacent registers:

- The first register to report the data for channel 1
- The second register to report status for channel 1
- The third register to report the data for channel 2

- The fourth register to report status for channel 2

Analog output modules use two adjacent registers:

- The first register to report status for channel 1
- The second register to report status for channel 2

When processing the I/O Island Input Data Image, consider the following rules:

1. The cluster error status bits is always at the start of the input map.
2. The cluster error status bits contains one bit per cluster. Each bit indicates either no error detected (= 1) or error detected (= 0).
3. A cluster error bit is set if one of the I/O modules within the cluster has zero in first 3 bits of the I/O module Group Cycle Status. The network interface module Group Cyclic Status (cluster 0) or Extender module Group Cyclic Status (clusters 1-24) is included in the derivation of the cluster error status bit for each cluster.
4. Before starting the module data for cluster 0, there are network interface module (NIM) GCS and the Extender module GCS.
5. After the end of the module data process for cluster 0 (or N) and before the module data process for cluster 1 (or N+1) there is the Extender module GCS for cluster 1 (or N+1).
6. The input map contains cyclic input data.
7. The input map contains cyclic health for all configured modules including both the Group Cyclic Status and the channels status for output modules, input modules and power supply modules (only GCS, where applicable).
8. The input status is laid out in cluster and slot order, low to high.
9. For each module the input data precedes the health data.
10. For output modules, only the health status is reported in the image.
11. The status includes the Group Cyclic Status byte for all module types.
12. The I/O module GCS byte (except the network interface module GCS and the Extender module GCS) is always in the 8 bits of the MSB of the status register (it may need more than one register for status).
13. Cyclic input data variables with a size greater than 1 byte starts in the LSB of a register. Each process parameter taking more than 1 byte starts at the beginning of a word.
14. Field Device Master (FDM) data cannot exceed 1024 bytes.
15. FDM data (including the fieldbus device modules) can be split over several PDUs according to their size. The registers of a fieldbus device cannot be split over two PDUs.
16. A fieldbus device cannot exceed 125 registers of data and it is arranged in the same PDU.
17. In channel mapping of an FDM module, each input channel is the aggregate of all the input channels of each fieldbus device and not only of each channel of a fieldbus device. For Example, for input image, FDM channel 0 aggregates the input channels of the fieldbus device connected to channel 0, and so on.

The following table represents the Modbus input Data process image and the corresponding previous rules:

Register	Word (Offset)	Bit														Rule
		MSB							LSB							
		15	14	13	12	11	10	9	8	7	6	5	4	3	2	
Modbus PDU 1																
5391	0	Cluster Error Status C0 to C15														1 and 2
5392	1	Reserved							cluster status C16 to C24							1 and 2
5393	2	Extender module GCS cluster 0							NIM GCS (Cluster 0 Only)							4
5394	3	Reserved							NTSDAI0215H input values							6
5395	4	NTSDAI0215H GCS							NTSDAI0215H channel health							12 and 7
5396	5	NTSDAO0205 GCS							NTSDAO0205 channel health							10, 7 and 12
5397	6	NTSACI0802X channel 0 input values														6
5398	7	NTSACI0802X channel 1 input values														6
5399	8	NTSACI0802X channel 2 input values														6
5400	9	NTSACI0802X channel 3 input values														6
5401	10	NTSACI0802X channel 4 input values														6
5402	11	NTSACI0802X channel 5 input values														6
5403	12	NTSACI0802X channel 6 input values														6
5404	13	NTSACI0802X channel 7 input values														6
5405	14	NTSACI0802X GCS							NTSACI0802X channel health							7 and 12
5406	15	NTSAHO0212H channel 0 QBackValue														6
5407	16	NTSAHO0212H channel 0 Meter Status														6
5408	17	NTSAHO0212H channel 0 ChannelStatus														6
5409	18	NTSAHO0212H channel 0 Primary Variable 1 (low)														6
5410	19	NTSAHO0212H channel 0 Primary Variable 1 (high)														6
5411	20	NTSAHO0212H channel 0 Secondary Variable 1 (low))														6
5412	21	NTSAHO0212H channel 0 Secondary Variable 1 (high)														6
5413	22	NTSAHO0212H channel 0 Tertiary Variable 1 (low))														6
5414	23	NTSAHO0212H channel 0 Tertiary Variable 1 (high)														6
5415	24	NTSAHO0212H channel 0 Quaternary Variable 1 (low)														6
5416	25	NTSAHO0212H channel 0 Quaternary Variable 1 (high)														6
5417	26	NTSAHO0212H channel 0 Current Value (low)														6
5418	27	NTSAHO0212H channel 0 Current Value (high)														6
5419	28	NTSAHO0212H channel 0 Percent Value (low))														6
5420	29	NTSAHO0212H channel 0 Percent Value (high)														6
5421 to 5435	30 to 44	NTSAHO0212H channel 1 values														6
5436	45	NTSAHO0212H GCS							Reserved							7 and 12
Modbus PDU 2																
5437 to 5469	78 to 139	NTSFMB0120 channel 0 - Fieldbus Device 0 Input Data (64 bytes)														16
5470 to 5531	93 to 155	NTSFMB0120 with Fieldbus Device 2 Registers														17
5532	140	NTSFMB0120 channel health 8-15							NTSFMB0120 channel health 0-7							7
5533	141	NTSFMB0120 channel health 24-31							NTSFMB0120 channel health 16-23							7
5534	142	NTSFMB0120 GCS							Reserved							12

Output Data Process Image

The output data process image contains the data written to the island from the Modbus over TCP/IP host. This data is used to update the output modules on the island bus. In the sample island bus assembly, there are two output modules, one discrete output module and one analog output module.

When processing the I/O Island Output Data Image, consider the following rules:

1. The Island I/O image begins with the Island Command and uses 1 register (the first one).
2. The discrete output module uses one Modbus register for data.
3. The analog output module requires two registers for each output channel.
4. FDM data cannot exceed 1024 bytes.
5. A fieldbus device cannot exceed 120 registers of data and it is arranged in the same PDU.

The following table represents the Modbus output Data process image and the corresponding previous rules:

Register	Word (Offset)	Bit														Rule
		MSB							LSB							
		15	14	13	12	11	10	9	8	7	6	5	4	3	2	
Modbus PDU 1																
0	0	Island Output Command														1
1	1	Reserved							NTSDAO0205 QValue 0..7							2
2	2	NTSAHO0212H QValue channel 0														3
3	3	NTSAHO0212H QValue channel 1														3
4 to 13	4 to 13	NTSFMB0120 channel 0 - Fieldbus Device 1 Output Data (20 bytes)														5

Consider the following guidelines for proper operation of the Edge I/O device:

1. At least one Modbus TCP/IP connection needs to be established between the scanner and the Edge I/O network interface module.
2. Up-to-date output data are sent to the module when the associated registers have been written for that module.
3. Up-to-date output data for a fieldbus device are sent to the FDM module when the associated registers have been written for that fieldbus device.
4. All the outputs of a module are updated in the same bus cycle. However, the outputs of different modules may be updated in different bus cycles.

EtherNet/IP Data Exchange

Overview

The assembly object combines various attributes from different application objects into a single attribute that can be transmitted using a single message. This message provides information about I/O data and the status of the EtherNet/IP network interface module.

Assembly objects are used to associate input data or output data, as seen from the perspective of the network. Specifically, an input generates data on the network, while an output consumes data from the network.

An I/O exchange may consist of multiple assemblies linked to a single Requested Packet Interval (RPI). In such cases, one assembly per connection is created to handle input and/or output I/O exchanges.

Maximum assembly sizes:

- The maximum input assembly size is 509 bytes.

- The maximum output assembly size is 505 bytes.

NOTE: For FDM modules, input and output data can be splitted into several assemblies if requiered. Data for one FDM channel cannot be splitted into several assemblies.

Input Data Process Image

Every entry in the process image is in a multiple-byte format. If modules on the island bus have input or output data entries that are not multiple bytes, the corresponding data in the process image is moved to the next byte boundary. The start of module data is aligned to byte boundaries.

The application of EtherNet/IP bit packing rules to the referenced island assembly result in 88 bytes of output data and 8 bytes of input data.

For example, a module with one bit of output data starts on a given byte boundary in the process image output data buffer. The next process image entry starts on the next byte boundary, thereby transmitting 7 unused bits of the first byte of the module. This results in latency during data transmission on the fieldbus. Bit packing allows bits of data on the fieldbus from different discrete I/O modules to be in a single byte, resulting in optimized bandwidth.

When processing the I/O island input data image, consider the following rules:

1. The first four bytes of the input process image contain island diagnostics information (Cluster Error Status).
2. Before the module data for cluster 0, there are the NIM GCS and the Extender module GCS.
3. Bit packing is organized based on the order in which the I/O modules are assembled on the island bus.
4. The data object (or echo output data object) for a specific module precedes the status object for that module.
5. If the combination of objects requires more than eight bits, the objects are placed in separate contiguous bytes. A single object cannot be split over two byte boundaries.
6. For analog input modules, channel 1 data is followed immediately by channel 1 status, then channel 2 data followed by channel 2 status.
7. The data object for each analog and discrete I/O module starts at the word boundary in the process image.
8. The image of an I/O module cannot be split over two assemblies.
9. After the end of the module data process for cluster 0 (or N) and before the module data process for cluster 1 (or N+1) there is the Extender module GCS for cluster 1 (or N+1).
10. The last byte of an I/O module data is the I/O module GCS.
11. FDM data cannot exceed 1024 bytes.
12. FDM data (including the fieldbus device modules) can be split over several assemblies according to their size. Data is organized to maintain data coherency for each connected device. Fieldbus device image cannot be split over two assemblies.

The following table represents the EtherNet/IP input Data process image and the corresponding previous rules:

Byte	Bit								Rule
	7	6	5	4	3	2	1	0	
EtherNet/IP Assembly 101									
0	Cluster status C0 to C7								1
1	Cluster status C8 to C15								1
2	Cluster status C16 to C23								1
3	Reserved							Cluster status 24	1
4	NIM GCS (Cluster 0 Only)								2
5	Extender module GCS cluster 0								2 and 9
6	NTSDAI0215H input values								4
7	NTSDAI0215H channels health								6
8	NTSDAI0215H GCS								10
9	NTSDAO0205 channel health								6
10	NTSDAO0205 GCS								10
11	NTSACI0802X input values channel 0 (1/2)								4
12	NTSACI0802X input values channel 0 (2/2)								4
13	NTSACI0802X input values channel 1 (1/2)								4
14	NTSACI0802X input values channel 1 (2/2)								4
15	NTSACI0802X input values channel 2 (1/2)								4
16	NTSACI0802X input values channel 2 (2/2)								4
17	NTSACI0802X input values channel 3 (1/2)								4
18	NTSACI0802X input values channel 3 (2/2)								4
19	NTSACI0802X input values channel 4 (1/2)								4
20	NTSACI0802X input values channel 4 (2/2)								4
21	NTSACI0802X input values channel 5 (1/2)								4
22	NTSACI0802X input values channel 5 (2/2)								4
23	NTSACI0802X input values channel 6 (1/2)								4
24	NTSACI0802X input values channel 6 (2/2)								4
25	NTSACI0802X input values channel 7 (1/2)								4
26	NTSACI0802X input values channel 7 (2/2)								4
27	NTSACI0802X channel health								6
28	NTSACI0802X GCS								10
29	NTSAHO0212H channel 0 QBackValue (1/2)								4
30	NTSAHO0212H channel 0 QBackValue (2/2)								4
31	NTSAHO0212H channel 0 Meter Status (1/2)								4
32	NTSAHO0212H channel 0 Meter Status (2/2)								4
33	NTSAHO0212H channel 0 ChannelStatus								4
34	NTSAHO0212H channel 0 Variable 1 (1/4)								4
35	NTSAHO0212H channel 0 Variable 1 (2/4)								4
36	NTSAHO0212H channel 0 Variable 1 (3/4)								4
37	NTSAHO0212H channel 0 Variable 1 (4/4)								4
38	NTSAHO0212H channel 0 Variable 2 (1/4)								4

Byte	Bit								Rule
	7	6	5	4	3	2	1	0	
39	NTSAHO0212H channel 0 Variable 2 (2/4)								4
40	NTSAHO0212H channel 0 Variable 2 (3/4)								4
41	NTSAHO0212H channel 0 Variable 2 (4/4)								4
42	NTSAHO0212H channel 0 Variable 3 (1/4)								4
43	NTSAHO0212H channel 0 Variable 3 (2/4)								4
44	NTSAHO0212H channel 0 Variable 3 (3/4)								4
45	NTSAHO0212H channel 0 Variable 3 (4/4)								4
46	NTSAHO0212H channel 0 Variable 4 (1/4)								4
47	NTSAHO0212H channel 0 Variable 4 (2/4)								4
48	NTSAHO0212H channel 0 Variable 4 (3/4)								4
49	NTSAHO0212H channel 0 Variable 4 (4/4)								4
50	NTSAHO0212H channel 0 Current Value (1/4)								4
51	NTSAHO0212H channel 0 Current Value (2/4)								4
52	NTSAHO0212H channel 0 Current Value (3/4)								4
53	NTSAHO0212H channel 0 Current Value (4/4)								4
54	NTSAHO0212H channel 0 Percent Value (1/4)								4
55	NTSAHO0212H channel 0 Percent Value (2/4)								4
56	NTSAHO0212H channel 0 Percent Value (3/4)								4
57	NTSAHO0212H channel 0 Percent Value (4/4)								4
58 to 86	NTSAHO0212H channel 1 values								4
87	NTSAHO0212H channel health								6
88	NTSAHO0212H GCS								10
89 to 184	NTSFMB0120 channel 0 - Slave Device 0 Input Data (64 bytes)								6
185 to 308	NTSFMB0120 channel 1 - Slave Device 1 Input Data (124 bytes)								6
309	NTSFMB0120 channel health 0-7								6
310	NTSFMB0120 channel health 8-15								6
311	NTSFMB0120 channel health 16-23								6
312	NTSFMB0120 channel health 24-32								6
313	NTSFMB0120 GCS								9
314 to 512 ⁽¹⁾	...								—
EtherNet/IP Assembly 103									
513	NTSDAI0215H input values								8 and 4
514	NTSDAI0215H channel health								6
515	NTSDAI0215H GCS								10
516	NTSDAO0205 channel health								4
517	NTSDAO0205 GCS								10

⁽¹⁾ Following I/O image layout does not correspond to the referenced island. In the context of this example, this represents a larger island in order to split its I/O image over at least 2 connections. The first 5 input and output modules correspond to the referenced island.

Output Data Process Image

The output data process image contains the data written to the island from the EtherNet/IP scanner. This data is used to update the output modules on the island bus. In the sample island bus assembly, there are two output modules, one discrete output module and one analog output module.

When processing the I/O island input data image, consider the following rules:

1. The Island I/O image begins with the island command and uses 1 register (the first one).
2. The discrete output module uses one Modbus register for data.
3. The analog output module uses two registers, one for each output channel.
4. The image of an I/O module cannot be splitted over two assemblies.
5. FDM data cannot exceed 1024 bytes.
6. A fieldbus device cannot exceed 250 bytes of data and it is arranged in the same assembly.

The following table represents the EtherNet/IP input Data process image and the corresponding previous rules:

Byte	Bit								Rule
	7	6	5	4	3	2	1	0	
EtherNet/IP Assembly 102									
0	Island Output Command								1
1	Island Output Command								1
2	NTSDAO0205 QValue 0-7								2
3	NTSAHO0212H QValue channel 0 (low)								3
4	NTSAHO0212H QValue channel 0 (high)								3
5	NTSAHO0212H QValue channel 1 (low)								3
6	NTSAHO0212H QValue channel 1 (high)								3
7 to 26	NTSFMB0120 channel 0 - Fieldbus Device 0 Ouput Data (20 bytes)								3

Consider the following guidelines for proper operation of the Edge I/O device:

1. An EtherNet/IP connection must be established between the scanner and the network interface module (for each assembly OUT object).
2. All I/O Island assembly OUT objects must be initialized before the Edge I/O network interface module is able to send I/O commands to the I/O Island. At the beginning of the implicit exchange, the first command to the modules is applied upon the reception of all the objects in the network interface module.
3. If an output image is made up of several assemblies, for instance assembly #102 and #104, the first command to the modules is sent once both assemblies have been received.
4. Up-to-date output data is sent to a module when the corresponding assembly output objects have been updated.
5. Up-to-date output data is sent to the fieldbus device when the corresponding assembly output objects of the fieldbus device have been updated.

Modbus TCP Explicit Exchange

The Modbus TCP supports the following Modbus requests:

Function Code	Object ID	Function
FC03	-	<i>Read multiple registers</i>
FC16	-	<i>Write multiple registers</i>
FC23	-	<i>Read and Write multiple registers</i>
FC43	0	<i>VendorName</i>
	1	<i>ProductName</i>
	2	<i>MajorMinorVersion</i>
	3	<i>VendorUrl</i>
NOTE: Minimum response time of explicit data exchange is 200 ms.		

Use the Unit ID 255 (FF hex) or 00 (00 hex) to send commands to the network interface module.

Index

C

Communication ports	
Ethernet port.....	29

N

Network Interface Modules	
NTSNEC1200.....	15
NTSNEC1200H	15

R

Rotary switch	
Ethernet.....	25

Schneider Electric
35 rue Joseph Monier
92500 Rueil Malmaison
France

+ 33 (0) 1 41 29 70 00

www.se.com

As standards, specifications, and design change from time to time, please ask for confirmation of the information given in this publication.

© 2024 – Schneider Electric. All rights reserved.

EIO0000004794.00