

# IP 67 monobloc I/O splitter boxes for fieldbuses

Advantys, FTB splitter boxes

## Presentation

To meet the needs of machine manufacturers and users, automation system architectures are becoming decentralised, while offering performances comparable to those obtained with a centralised structure.

Advantys FTB IP 67 monobloc I/O splitter boxes enable sensors and actuators to be connected in distributed automation systems using pre-assembled cables, thus reducing wiring time and costs, whilst at the same time increasing the operational availability of the installation.

These IP 67 protected splitter boxes can also be used within processes or machines in harsh environments (splashing water, oil, dust, etc.). For difficult environments (welding shops etc.), a range of Advantys FTB splitter boxes with a metal housing is available.

Advantys FTB splitter boxes allow distributed connection of sensors and actuators on machines via a fieldbus. They communicate on different buses such as: CANopen, DeviceNet, Profibus DP and INTERBUS.

Sensors and actuators are connected by means of standard M12 connectors.

Configuration and parametering of the Advantys FTB splitter boxes is carried out using configuration files (e.g.: .eds files for CANopen):

- either directly within the software workshop of the PLC used,
- or by using a SyCon type configurator (refer to our Modicon Premium automation platform catalogue).

Advantys FTB splitter boxes are available with different input (≡ 24 V IEC type 2) and output (transistor ≡ 24 V/1.6 A) configurations:

- Mixed 8 input and 8 output splitter boxes, allowing connection of either 8 sensors and 8 actuators or 8 actuators with integrated diagnostics function.
- Mixed 12 input and 4 output splitter boxes, allowing connection of either 12 sensors and 4 actuators or 4 sensors and 4 actuators with integrated diagnostics function.
- 16 input splitter boxes allowing connection of either 16 sensors or 8 sensors with integrated diagnostics function.
- Mixed 16 input or output splitter boxes, configurable per channel, allowing all possible combinations: 16 inputs, 15 inputs/1 output, 14 inputs/2 outputs, ..., 16 outputs.

## Functions

### Selection of signal type per channel

- Each M12, 5-pin connector on Advantys FTB splitter boxes allows the connection of 2 signals. Depending on the type of splitter box, these can be:
  - 1 sensor input signal,
  - 1 diagnostic input signal,
  - 1 actuator output signal.

Signal type, depending on splitter box selected:

	FTB	1●●16E	1●●08E08S	1●●12E04S	1●●16C	1D●08E08C
M12	Contact 4	Input	Output	0...3: Input 4...7: Output	Input Output	Input Output
	Contact 2	Input Diagnostic	Input Diagnostic	Input Diagnostic	Input Output Diagnostic	Input Diagnostic

**Note:** either a normally open (N/O) or a normally closed (N/C) contact can be chosen for each input signal.

# IP 67 monobloc I/O splitter boxes for fieldbuses

Advantys, FTB splitter boxes

## Diagnostics

Each Advantys FTB splitter box has one LED per channel to indicate the status of the channel and to enable fast and precise location of a fault. Fault monitoring diagnostics are indicated on the splitter box by LEDs and are fed back to the control system (PLC) via the bus.

There are 2 levels of diagnostics:

- diagnostics per channel,
- diagnostics per splitter box.

## Diagnostics per channel

### ■ Sensor short-circuit

A short-circuit or overload on contact 1 of the M12 female connector blows the self-resetting fuse. Each M12 connector is individually protected. A red LED indicates the fault on the corresponding M12 connector. This fault is signalled to the Master. Supply to the sensors is automatically restored after elimination of the fault.

### ■ Actuator short-circuit

A short-circuit or overload of an output causes disconnection of this output. The fault is signalled to the Master. A red LED indicates the fault on the corresponding M12 connector. The output does not restart automatically. After having eliminated the cause of the fault, the channel must be reset by the PLC. This operation erases the short-circuit memory.

### ■ Actuator warning

When the output is at state 0, the contact corresponding to the M12 female connector is checked for presence of 24 V voltage. If + 24 V is present, it means there is a "short-circuit". A red LED indicates the fault on the corresponding M12 connector. The fault is signalled to the Master.

## Diagnostics per splitter box

### ■ Sensor/actuator supply status.

### ■ "Undervoltage" fault on the I/O supply.

### ■ Sensor short-circuit.

### ■ Actuator short-circuit.

## Use of the sensor/actuator diagnostics function

Advantys FTB splitter boxes allow the use of sensors and actuators incorporating an integrated diagnostics function (DESINA type). Configuring contact 2 of each M12 connector as a diagnostic input enables detection of external faults associated with the sensors or actuators.

This information enables the following faults to be detected:

- damage to the detection surface,
- faulty electronics,
- no load.

Selection of either the sensor input or diagnostic input function on contact 2 is made channel by channel, by entering parameters, when configuring the splitter box.

Fault indication by a red LED is possible for each channel configured as a diagnostic input (LEDs 10 to 17).

Example of connection of a sensor with integrated diagnostics function:

Using the M12 diagnostics adaptor accessory **FTX DG12**, it is possible to monitor breaks in wiring to sensors or actuators which do not have an integrated diagnostics function.

Example of connection of a sensor with integrated diagnostics function

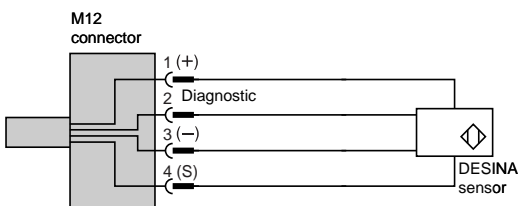

Example of connection of a standard sensor with the diagnostics adaptor

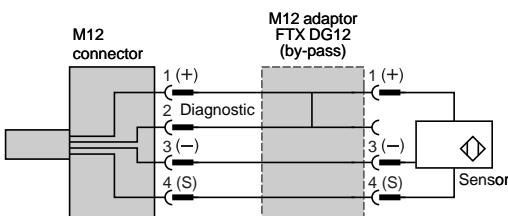

# IP 67 monobloc I/O splitter boxes for fieldbuses

Advantys, FTB splitter boxes  
CANopen and DeviceNet buses

Advantys FTB splitter boxes are of the monobloc type. Each splitter box comprises one part for connection of sensors and actuators by means of M12 connectors, and one part for connection of splitter boxes on CANopen and DeviceNet fieldbuses. These splitter boxes enable inputs/outputs to be located remotely, as close as possible to the equipment being controlled.

## CANopen bus presentation

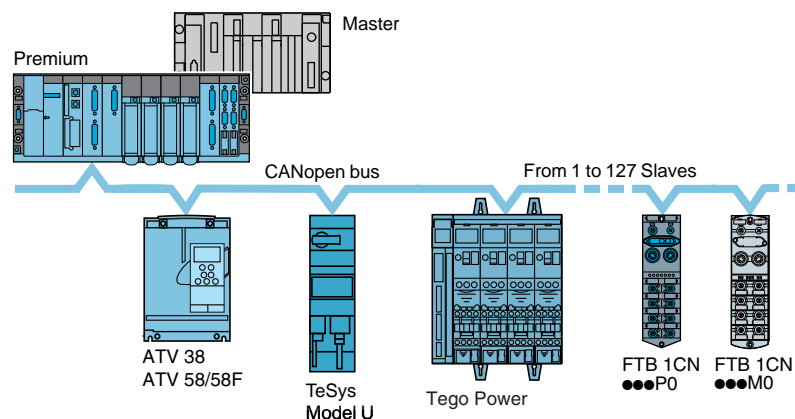

The CAN system, initially developed for real-time exchange of information in the automobile industry, is now being used more and more throughout industry. There are several fieldbuses based on CAN base layers and components. The CANopen bus conforms to international standard ISO 11898, promoted by the “CAN in Automation” association (a grouping of manufacturers and users), and guarantees a high degree of openness and inter-operability due to its communication profiles and its standardised equipment. The CANopen bus is now recognised, in Europe, as the reference standard for building industrial systems based on the CAN concept. The CANopen bus is a Multimaster bus, based on the Master/Slave principle. The physical link consists of a shielded twisted pair, to which up to a maximum of 127 Slaves can be connected by simple tap-off. The binary rate varies, depending on the length of the bus, from 1 Mbit/s for 40 m to 50 Kbit/s for 1000 m. Each end of the bus must be fitted with a line terminator.

The CANopen bus is a set of profiles on CAN systems, possessing the following characteristics:

- Open bus system.
- Data exchanges in real-time without overloading the protocol.
- Modular design allowing modification of size.
- Interconnection and interchangeability of devices.
- Standardised configuration of networks.
- Access to all device parameters.
- Synchronisation and circulation of data from cyclic and/or event-controlled processes (short system response time).
- Exchanges possible with numerous international manufacturers.

# IP 67 monobloc I/O splitter boxes for fieldbuses

Advantys, FTB splitter boxes  
CANopen and DeviceNet buses

## DeviceNet bus presentation

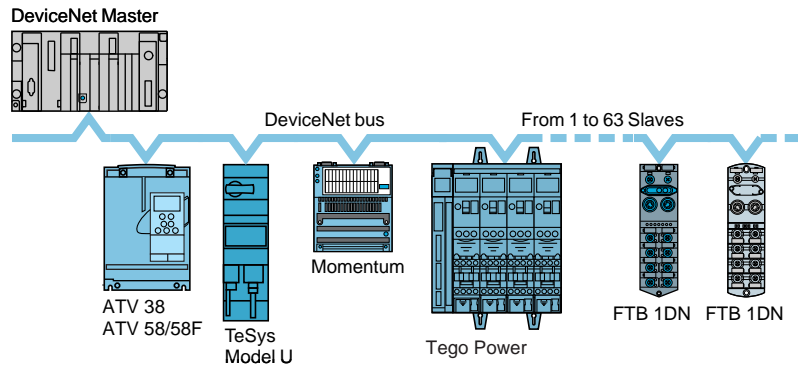

The DeviceNet system is a sensor/actuator bus system of the open Low-End type, used in various industrial applications and, in particular, the automobile industry. It is based on CAN technology (OSI layers 1 and 2).

The DeviceNet bus is based on the Master/Slave principle.

The physical link consists of 2 shielded twisted pairs (2 wires for data, 2 wires for auxiliary supply to sensors), to which up to a maximum of 63 slaves can be connected. The binary rate varies, depending on the length of the bus, from 500 K bits/s for 100 m to 125 Kbit/s for 500 m.

Each end of the bus must be fitted with a line terminator.

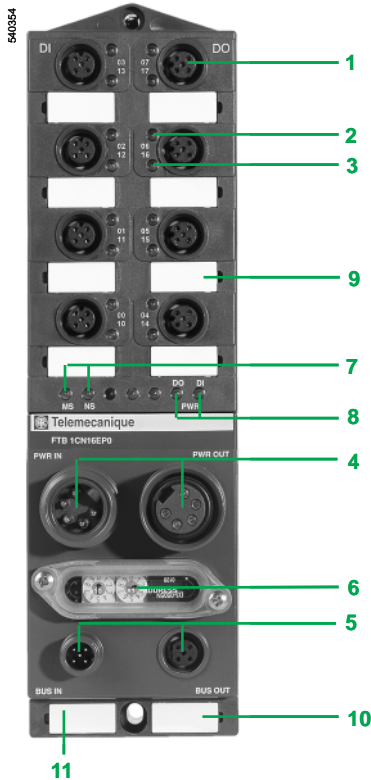

## Description

CANopen and DeviceNet monobloc I/O splitter boxes FTB 1CN and FTB 1DN have the following on the front face:

- 1 Eight M12 female connectors for connection of sensors and actuators (2 channels per connector).
- 2 Eight channel status indicator lights (00 to 07).
- 3 Eight channel status indicator lights (10 to 17) or channel diagnostic indicator lights (00 to 07) depending on the splitter box configuration.
- 4 Two 7/8 connectors for connecting the  $\pm$  24 V sensor and actuator power supplies: male for PWR IN, female for PWR OUT.
- 5 One M12 male connector (bus IN) and one M12 female connector (bus OUT) for connection of the CANopen and DeviceNet buses.
- 6 Access to coding and speed selection wheels.
- 7 Two bus diagnostic LEDs.
- 8 Two  $\pm$  24 V sensor and actuator supply status LEDs.
- 9 Eight channel marker labels.
- 10 Two splitter box marker labels.
- 11 Splitter box functional earth connection (beneath the label).

## Configuration

### CANopen bus configuration

A .eds file is assigned to each product, which contains all the important information relating to the product. An icon (.dib) is also available for installation in the system configurator.

Please refer to the configuration software documentation for the import of .eds files. Following the CANopen system initialisation phase, all the Slaves signal their presence on the bus by means of a "Boot-Up" message. A setting-up configurator (e.g.: SyCon) can then start to read and register the CANopen bus and, on the basis of the data obtained, assign a corresponding .eds file to each Slave. Based on the .eds file data, the Master creates a peripheral image of all the Slaves detected by the PLC. The user can assign I/O bytes to logic addresses within the PLC.

### Addressing

The addresses are configurable from 1 to 99 by means of 2 coding wheels (x 10 and x 1). A 3rd coding wheel enables the data transmission speed to be selected (position 0 = automatic speed recognition from 125 Kbit/s to 1 Mbit/s).

### DeviceNet bus configuration

A .eds file is assigned to each product, which contains all the important information relating to the product. An icon (.dib for CANopen, .ico for DeviceNet) is also available for installation in the system configurator.

When the network is scanned, the identification data is compared with that of the Slaves present on the network and assigned accordingly. After the scanning phase, the scanner will have identified all the Slaves and saved information relating to data length and operating mode.

The DeviceNet bus Master establishes a peripheral image of all the devices detected on the DeviceNet bus and incorporates them according to their physical location in a Scan list. The user can then assign the Scan list, according to the peripheral image of the bus devices, to logic addresses in the PLC.

The addresses are configurable from 1 to 63 by means of 2 coding wheels (x 10 and x 1). A 3rd coding wheel enables the data transmission speed to be selected

# IP 67 monobloc I/O splitter boxes for fieldbuses

Advantys, FTB splitter boxes  
CANopen and DeviceNet buses

## Cabling system

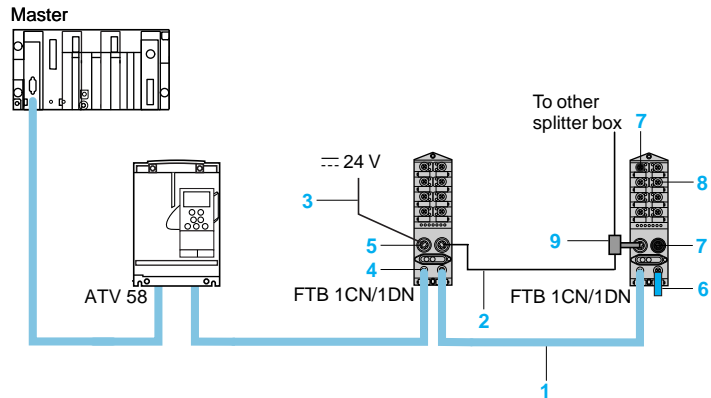

## Cabling accessories

### CANopen and DeviceNet bus connection cables

Cables FTX CN32●● enable connection of splitter boxes FTB 1CN and FTB 1DN to CANopen and DeviceNet fieldbuses.

- 1 **FTX CN32●●**: cables fitted with 2 elbowed M12, 5-pin connectors, one at each end, for chaining the bus between two splitter boxes.

### Sensor and actuator $\overline{\text{24 V}}$ power supply connection cables

Cables FTX DP2●●● enable connection of  $\overline{\text{24 V}}$  power supplies to splitter boxes FTB 1CN and FTB 1DN. Two types of cable are available, in various lengths:

- 2 **FTX DP22●●**: cables fitted with two 7/8, 5-pin connectors, one at each end, for chaining  $\overline{\text{24 V}}$  power supplies between two splitter boxes.
- 3 **FTX DP21●●**: cables fitted with a 7/8, 5-pin connector at one end, with the other end free for connection of  $\overline{\text{24 V}}$  power supplies.

### Connectors

- 4 **FTX CN12●5**: M12, 5-pin, male and female connectors for bus cables.
- 5 **FTX C78●●**: 7/8, 5-pin, male and female connectors for  $\overline{\text{24 V}}$  power supply cables.

### Other components

- 6 **FTX CNTL12**: bus line terminator fitted with an M12 connector.
- 7 **FTX C●●●B**: sealing plugs for 7/8, M12 and M8 connectors.
- 8 **FTX CY12●●**: Y-connector for M12 and M8 connectors.
- 9 **FTX CNCT1**: T-connector fitted with two 7/8, 5-pin connectors for power supply cable.

# IP 67 monobloc I/O splitter boxes for fieldbuses

Advantys, FTB splitter boxes  
Profibus DP bus

Advantys FTB splitter boxes are of the monobloc type.

Each splitter box comprises one part for connection of sensors and actuators by means of M12 connectors, and one part for connection of splitter boxes on Profibus DP fieldbus.

This splitter box enables inputs/outputs to be located remotely, as close as possible to the equipment being controlled.

## Profibus DP presentation

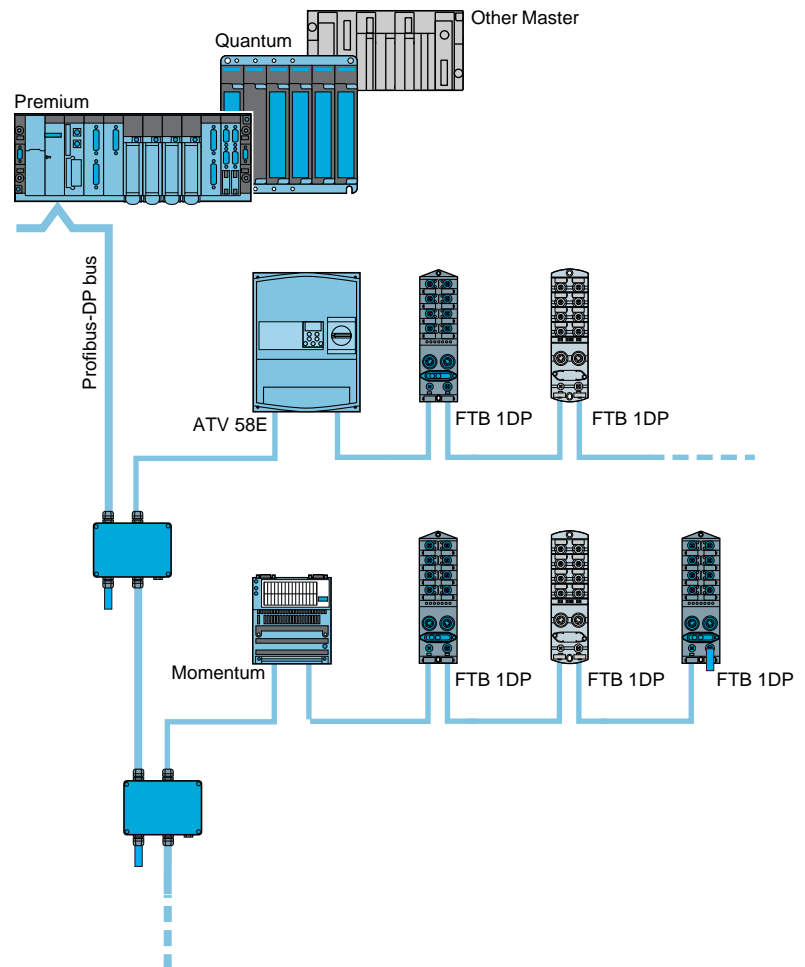

The Profibus DP (Process Fieldbus Decentralized Peripheral) is an open type fieldbus system for industrial applications. The Profibus standard is described in standard EN 50170.

The physical link is a simple, type A, shielded twisted pair.

Data exchange between the Master (processing unit) and the Slaves (decentralised devices) is performed in a cyclic manner.

A maximum of 32 Slaves can be connected to a bus segment. To increase the number of Slaves, repeaters must be installed in order to create new bus segments. The repeaters also provide galvanic isolation of the bus segments.

The total number of slaves must not exceed 126.

The bus must be fitted with a line terminator at each end of each segment created.

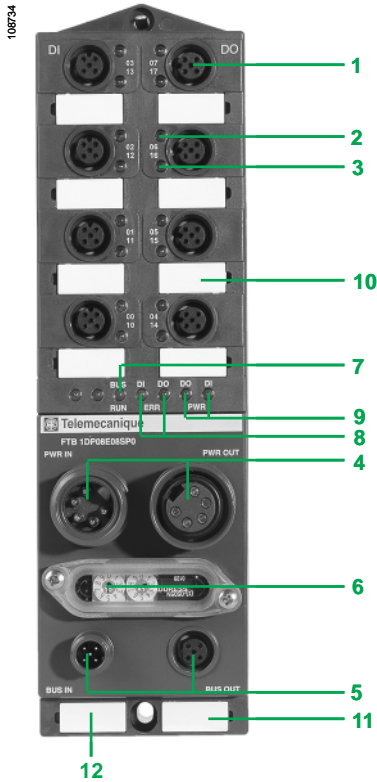

## Description

Profibus DP monobloc I/O splitter boxes FTB 1DP have the following on the front face:

- 1 Eight M12 female connectors for connection of sensors and actuators (2 channels per connector).
- 2 Eight channel status indicator lights (00 to 07).
- 3 Eight channel status indicator lights (10 to 17) or channel diagnostic indicator lights (00 to 07) depending on the splitter box configuration.
- 4 Two 7/8 connectors for connecting the 24 V sensor and actuator power supplies: male for PWR IN, female for PWR OUT.
- 5 One M12 male connector (bus IN) and one M12 female connector (bus OUT) for connection of the Profibus DP bus.
- 6 Access to the address coding wheels.
- 7 One bus diagnostics LED.
- 8 Two sensor/actuator diagnostic LEDs.
- 9 Two 24 V sensor and actuator supply status LEDs.
- 10 Eight channel marker labels.
- 11 Two splitter box marker labels.
- 12 Splitter box functional earth connection (beneath the label).

## Configuration

The Profibus DP identification number is a preset, non-modifiable element exclusive to each Slave.

A .gsd file is assigned to each product, which contains all the important information relating to the product. An icon (.dib) is also available for installation in the system configurator (please refer to the configuration software documentation for the import of .gsd files).

During configuration of the equipment, the Master receives precise criteria relating to the overall structure of the fieldbus via the system configurator. All necessary information relating to the type and operational behaviour of the various Slaves, as well as data concerning the identification number, is included in the .gsd file.

Example with SyCon configurator (refer to our Modicon Premium automation platform catalogue):

- Select the products for the application from the product catalogue library in the SyCon software (step 1),

- Product configuration (step 2):

- double-click on the product icon to access the product configuration menu,
- select the required product reference from the suggested list,
- select the associated functions that you wish to use with the product.

- Channel by channel, configure the type of signal that will be connected to it (step 3):

- input (N/O or N/C contact),
- diagnostic input (only applicable to channels 10 to 17),
- output.

## Addressing

For the Slaves, the assignment of addresses generally starts at address 3 (0-2 reserved for the Master). The addresses are configurable from 1 to 99 by means of 2 coding wheels (x 10 and x 1).

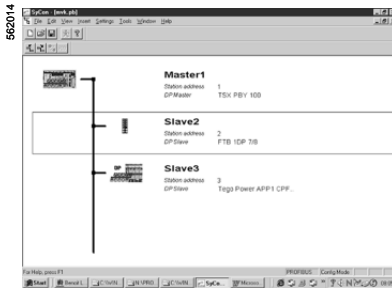

Step 1: Product selection

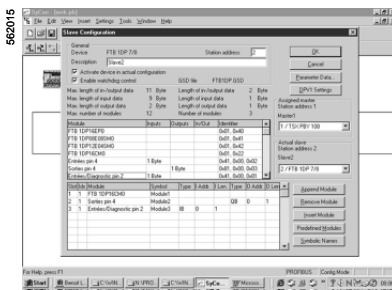

Step 2: Access to the configuration menu

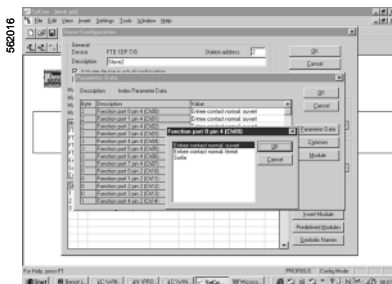

Step 3: Configuration

# IP 67 monobloc I/O splitter boxes for fieldbuses

Advantys, FTB splitter boxes  
Profibus DP bus

## Cabling system

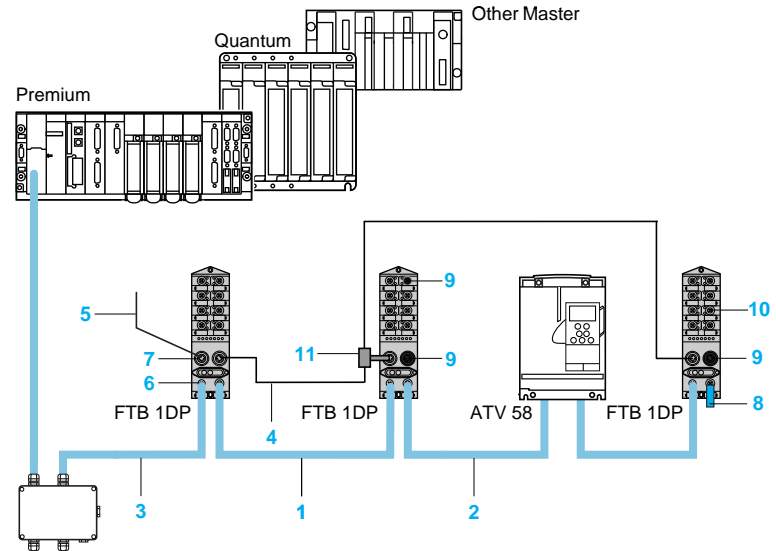

## Cabling accessories

### Profibus DP bus connection cables

Cables FTX DP●2●● enable connection of splitter boxes FTB 1DP to Profibus DP fieldbus.

- 1 **FTX DP12●●**: cables fitted with 2 straight M12, 5-pin connectors, one at each end, for chaining the bus between two splitter boxes.
- 2 **FTX DP32●●**: cables fitted with 2 elbowed M12, 5-pin connectors, one at each end, for chaining the bus between two splitter boxes.
- 3 **TSX PBSCA●00**: cables free at both ends.

### Sensor and actuator --- 24 V power supply connection cables

Cables FTX DP2●●● enable connection of --- 24 V power supplies to splitter boxes FTB 1DP. Two types of cable are available, in various lengths:

- 4 **FTX DP22●●**: cables fitted with two 7/8, 5-pin connectors, one at each end, for chaining --- 24 V power supplies between two splitter boxes.
- 5 **FTX DP21●●**: cables fitted with a 7/8, 5-pin connector at one end, with the other end free for connection of --- 24 V power supplies.

### Connectors

- 6 **FTX DP12●5**: M12, 5-pin, male and female connectors for bus cables.
- 7 **FTX C78●●**: 7/8, 5-pin, male and female connectors for --- 24 V power supply cables.

### Other components

- 8 **FTX DPTL12**: bus line terminator fitted with an M12 connector.
- 9 **FTX C●●●B**: sealing plugs for 7/8, M12 and M8 connectors.
- 10 **FTX CY12●●**: Y-connector for M12 and M8 connectors.
- 11 **FTX CNCT1**: T-connector fitted with two 7/8, 5-pin connectors for power supply cable.

# IP 67 monobloc I/O splitter boxes for fieldbuses

Advantys, FTB splitter boxes  
INTERBUS bus

Advantys FTB splitter boxes are of the monobloc type. Each splitter box comprises one part for connection of sensors and actuators by means of M12 connectors, and one part for connection of splitter boxes on INTERBUS fieldbus. This splitter box enables inputs/outputs to be located remotely, as close as possible to the equipment being controlled.

## INTERBUS bus presentation

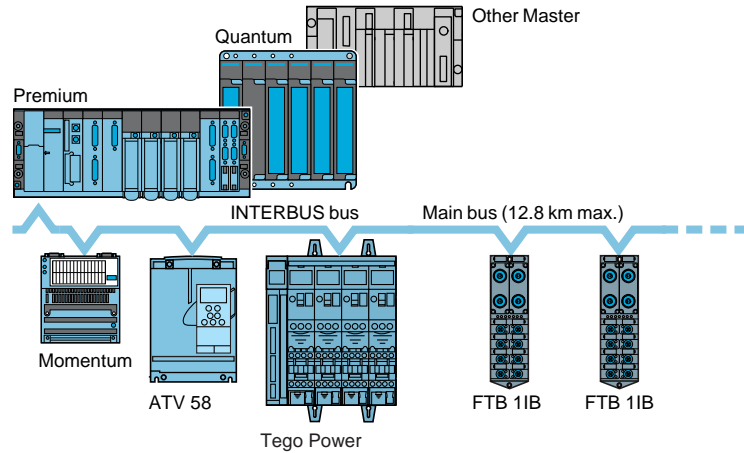

INTERBUS is a serial link type fieldbus for sensors and actuators which satisfies the requirements of industrial environments. Conforming to the standard specification, an INTERBUS can operate with up to 256 Slaves:

- 12.8 km max. with copper conductors,
- beyond 80 km using fibre optic cables.

The distance between 2 different components of the bus must not exceed 400 m (for copper conductors).

The INTERBUS system is designed in the form of a loop and has the structure of a shift register distributed on the bus. Each Slave, with its registers, constitutes a component in this shift register loop.

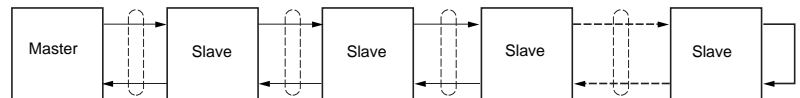

The cyclic exchange of information between the Master and the Slaves is carried out independently by the Master.

The physical link consists of 3 pairs of twisted wires with common shielding.

In addition to the main bus (long distance bus), a local bus can be set up.

- Characteristics of INTERBUS local bus,
  - the 24 V power supply also passes along the system cable (3 additional wires, 0.75 mm<sup>2</sup>) to supply the electronics and the Slave peripherals,
  - the maximum current is limited to 4.5 A, in accordance with the specification,
  - the maximum distance is 50 metres.

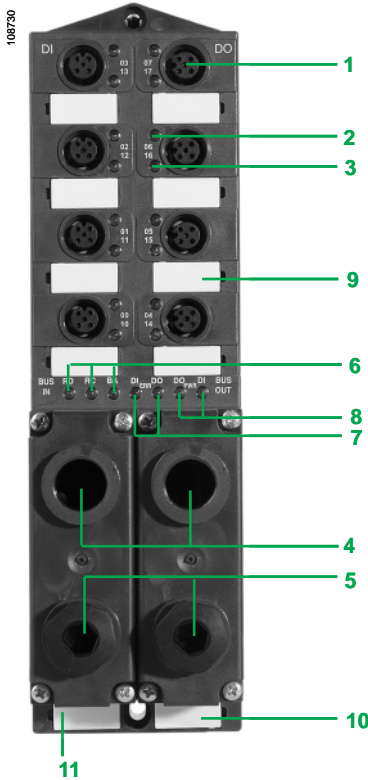

## Description

INTERBUS monobloc I/O splitter boxes FTB 1IB have the following on the front face:

- 1 Eight M12 female connectors for connection of sensors and actuators (2 channels per connector).
- 2 Eight channel status indicator lights (00 to 07).
- 3 Eight channel status indicator lights (10 to 17) or channel diagnostic indicator lights (00 to 07) depending on the splitter box configuration.
- 4 Two terminal blocks for connection of  $\pm$  24 V sensor and actuator power supplies (IN and OUT) (connectors included with product).
- 5 Four terminal blocks for connection of the INTERBUS bus (connectors included with product).
- 6 Three bus diagnostic LEDs.
- 7 Two sensor/actuator diagnostic LEDs.
- 8 Two  $\pm$  24 V sensor and actuator supply status LEDs.
- 9 Eight channel marker labels.
- 10 Two splitter box marker labels.
- 11 Splitter box functional earth connection (beneath the label).

## Configuration

Each Slave has its own identification code, so that it can be clearly identified by the INTERBUS Master. This code is configured by the manufacturer and cannot be subsequently modified. The characteristics of this code are defined in the INTERBUS specification.

Start-up of the system is immediately followed by an identification cycle. During this system initialisation phase, the identification data of all the Slaves is read by the Master according to their position in the bus. This data will, in particular, be used to prepare the peripheral image at the Master.

The following cycles are simple data cycles, whose only purpose is the exchange of process data between the Master and the Slaves.

## Addressing

The INTERBUS system allows either physical addressing or logic addressing:

### ■ Physical addressing

The assignment of the Master's peripheral image to the process image within the PLC corresponds to the layout of the splitter boxes in the fieldbus.

### ■ Logic addressing

During configuration, it is possible to carry out manual logic addressing using configuration software (for example: CMDtools), independently of the Master used. During this operation, logic addressing of the peripheral image or of parts of this image is carried out to the process image within the PLC.

# IP 67 monobloc I/O splitter boxes for fieldbuses

Advantys, FTB splitter boxes  
INTERBUS bus

## Cabling system

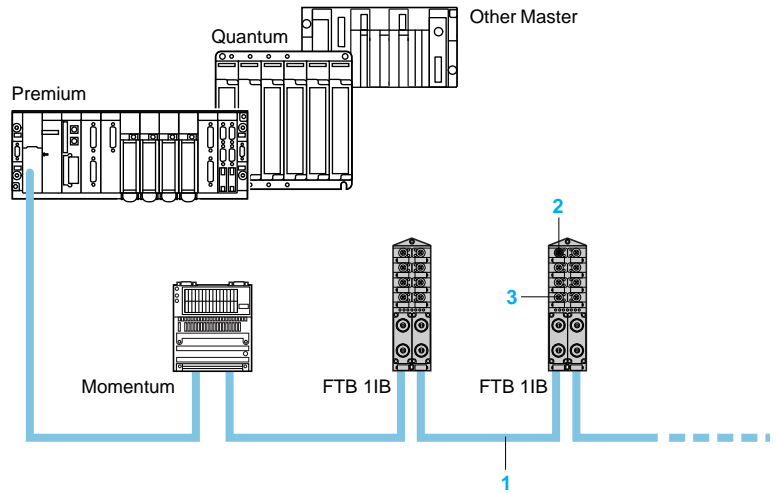

## Cabling accessories

### Connection cables for the bus and for sensor and actuator :: 24 V power supplies

Cables FTX IB12●● enable connection of splitter boxes FTB 1B to INTERBUS fieldbus.

- 1 **FTX IB12●●**: cables fitted with 2 sets of connectors at each end for chaining the bus and power supplies between two splitter boxes.

### Other components

- 2 **FTX CM●●B**: sealing plugs for M12 and M8 connectors.
  - 3 **FTX CY12●●**: Y-connector for M12 and M8 connectors.
- FTX CPE10**: cable gland.

# IP 67 monobloc I/O splitter boxes for fieldbuses

Advantys, FTB splitter boxes

Environmental characteristics			
Product certifications			cULus
Temperature	Operation	°C	0...+ 55
	Storage	°C	- 25...+ 70
Degree of protection	Conforming to IEC 60529		IP 67
Altitude		m	0...2000
Vibration resistance	Conforming to IEC 68-2-6, test Fc	Hz	For plastic housing 5 ≤ f ≤ 57.55 (constant amplitude = 1.5 mm) 57.55 ≤ f ≤ 500 (constant acceleration = 10 gn)
			For metal housing 5 ≤ f ≤ 70 (constant amplitude = 1.5 mm) 70 ≤ f ≤ 500 (constant acceleration = 15 gn)
Shock resistance	Conforming to IEC 68-2-27, test Ea		For plastic housing 30 gn, for 11 ms
			For metal housing 50 gn, for 11 ms
Resistance to electrostatic discharge	Conforming to IEC 61000-4-2	kV	Contact: ± 4 Air: ± 8
Resistance to radiated fields	Conforming to IEC 61000-4-3	V/m	10
Immunity to fast transient currents	Conforming to IEC 61000-4-4	kV	Power supply: ± 2 Signal: ± 2
Surge withstand	Conforming to IEC 61000-4-5	V	Power supply: (symmetrical) ± 500, (asymmetrical) ± 1000 Signals: (symmetrical) ± 500, (asymmetrical) ± 1000 Earth/PE: ± 500
Immunity to conducted disturbance	Conforming to IEC 61000-4-6	Vrms	10
Resistance to magnetic fields, 50 Hz	Conforming to IEC 61000-4-8	A/m	30
Mounting			All positions
Mechanical fixing			Fixing by two M4 screws for plastic housing (tightening torque 1.5 Nm) Fixing by two M6 screws for metal housing (tightening torque 9 Nm)

Fieldbus characteristics					
Bus type		CANopen	DeviceNet	Profibus DP	INTERBUS
Structure	Type	EN 50325 ISO 11898	EN 50325 ISO 11898 CAN, layer 7 DeviceNet	DIN 19245 EN 50170	DIN 19258 EN 50254
	Access method	Multimaster, priority information	Master-Slave	Master-Slave, Multi-Master	Master-Slave
Transmission	Binary rate	1 Mbit/s	500 Kbit/s	12 Mbit/s	500 Kbit/s
	Medium	2 twisted, shielded wires	4 twisted, shielded wires	2 twisted, type A, shielded wires (RS 485)	3 twisted pairs with common shielding Fibre optic
Configuration	Maximum number of devices	127	63	32 without repeater 126 with repeaters	256
	Maximum length of bus	<b>At 1 Mbit/s:</b> - Max. tap-off length: 0.3 m - Max. cumulative tap-off length: 1.5 m  <b>At 500 Kbit/s:</b> - Max. tap-off length: 6 m - Max. cumulative tap-off length: 30 m	<b>Main line:</b> - 500 m without repeater, - 3 km with repeater  <b>Tap-off:</b> 6 m max.	Without repeater: <b>At 12 Mbit/s:</b> - 100 m max.  <b>At 1.5 Mbit/s:</b> - 200 m max.  <b>At 500 Kbit/s:</b> - 400 m max.  <b>At &lt; 93.75 Kbit/s:</b> - 1.2 km max.	<b>Main bus link</b> (long distance bus): 12.8 km  <b>Local bus link:</b> 50 m

# IP 67 monobloc I/O splitter boxes for fieldbuses

Advantys, FTB splitter boxes

Input/output characteristics						
Splitter box type	FTB	1●●16E●●	1●●08E08SP●	1●●12E04SP●	1●●16C●●	1●●08E08CM0
Bus type		All types of bus				CANopen bus, DeviceNet bus and Profibus DP bus
Number of inputs/outputs		16 I (8 I + 8 diagnostic inputs)	16 I/O (8 O + 8 diagnostic inputs)	16 I/O (4 I + 4 O + 8 diagnostic inputs)	16 I/O (8 I/O + 8 diagnostic I/O)	8 I + 8 I/O (8 I + 8 diagnostic I/O)
Internal consumption of splitter box	mA	120				
Operating voltage	--- V	24				
Splitter box max. supply current	A	9 (10 for INTERBUS)				
Bus and I/O undervoltage detection	V	< 18				
Built-in short-circuit protection	mA	< 100, automatic tripping				
	mA	> 100, reset				
Input characteristics						
Number of inputs		16 I	8 I	12 I	0...16 I	8 I + 0...8 I
Conformity to IEC 1131-2		Type 2				
Compatibility with 2-wire/3-wire proximity sensors		Yes				
Input values	Nominal voltage	--- V	24			
	Maximum current	mA	200			
	Sensor power supply	V	18...30			
Logic		Positive				
Input filtering	ms	1				
Protection against reversed polarity		Yes				
Output characteristics						
Number of outputs		–	8 O	4 O	0...16 O	0...8 O
Output type		–	Transistor			
Nominal output values	Voltage	V	–	--- 24		
	Current	A	–	1.6		
Overvoltage protection		–	Yes (suppressor diode)			
Maximum switching cycles	Hz	–	20			
Maximum lamp load	W	–	10			
Output connection/cable lengths	mm <sup>2</sup>	–	0.75/10 m maximum 0.34/5 m maximum			

# IP 67 monobloc I/O splitter boxes for fieldbuses

Advantys, FTB splitter boxes



FTB 1CN...P0



FTB 1CN...M0



FTB 1DN...P0



FTB 1DN...M0



FTB 1DP...P0



FTB 1DP...M0



FTB 1IB

Number of I/O	Number, type of inputs (1)	Number, type of outputs (2)	Connection by	Housing type	Reference	Weight kg
<b>Monobloc splitter boxes for CANopen bus</b>						
16	8	8, transistor	8 x M12 female connectors	Plastic	<b>FTB 1CN08E08SP0</b>	0.430
	12	4, transistor	8 x M12 female connectors	Plastic	<b>FTB 1CN12E04SP0</b>	0.450
	16	–	8 x M12 female connectors	Plastic Metal	<b>FTB 1CN16EP0</b> <b>FTB 1CN16EM0</b>	0.440 0.820
<b>16 configurable</b>	0...16	0...16, transistor	8 x M12 female connectors	Plastic Metal	<b>FTB 1CN16CP0</b> <b>FTB 1CN16CM0</b>	0.450 0.820
<b>16 of which 8 configurable</b>	8 + 0...8	0...8, transistor	8 x M12 female connectors	Metal	<b>FTB 1CN08E08CM0</b>	0.820
<b>Monobloc splitter boxes for DeviceNet bus</b>						
16	8	8, transistor	8 x M12 female connectors	Plastic	<b>FTB 1DN08E08SP0</b>	0.450
	12	4, transistor	8 x M12 female connectors	Plastic	<b>FTB 1DN12E04SP0</b>	0.450
	16	–	8 x M12 female connectors	Plastic Metal	<b>FTB 1DN16EP0</b> <b>FTB 1DN16EM0</b>	0.430 0.820
<b>16 configurable</b>	0...16	0...16, transistor	8 x M12 female connectors	Plastic Metal	<b>FTB 1DN16CP0</b> <b>FTB 1DN16CM0</b>	0.450 0.820
<b>16 of which 8 configurable</b>	8 + 0...8	0...8, transistor	8 x M12 female connectors	Metal	<b>FTB 1DN08E08CM0</b>	0.820
<b>Monobloc splitter boxes for Profibus DP bus</b>						
16	8	8	8 x M12 female connectors	Plastic	<b>FTB 1DP08E08SP0</b>	0.430
	12	4	8 x M12 female connectors	Plastic	<b>FTB 1DP12E04SP0</b>	0.430
	16	–	8 x M12 female connectors	Plastic Metal	<b>FTB 1DP16EP0</b> <b>FTB 1DP16EM0</b>	0.430 0.820
<b>16 configurable</b>	0...16	0...16	8 x M12 female connectors	Plastic Metal	<b>FTB 1DP16CP0</b> <b>FTB 1DP16CM0</b>	0.430 0.820
<b>16 of which 8 configurable</b>	8 + 0...8	0...8	8 x M12 female connectors	Metal	<b>FTB 1DP08E08CM0</b>	0.820
<b>Monobloc splitter boxes for INTERBus bus</b>						
16	8	8	8 x M12 female connectors	Plastic	<b>FTB 1IB08E08SP1</b>	0.430
	12	4	8 x M12 female connectors	Plastic	<b>FTB 1IB12E04SP1</b>	0.440
	16	–	8 x M12 female connectors	Plastic	<b>FTB 1IB16EP1</b>	0.430
<b>16 configurable</b>	0...16	0...16	8 x M12 female connectors	Plastic	<b>FTB 1IB16CP1</b>	0.430

(1) --- 24 V IEC type 2.  
(2) --- 24 V/1.6 A.

# IP 67 monobloc I/O splitter boxes for fieldbuses

Advantys, FTB splitter boxes

108767



FTX DP2115

## Connection accessories

Description	Composition	Length m	Reference	Weight kg	
<b>For CANopen/DeviceNet buses</b>					
<b>Bus connection cables</b>	Fitted with 2 elbowed M12, 5-pin connectors, A encoded, one at each end	0.3	FTX CN3203	0.040	
		0.6	FTX CN3206	0.070	
		1	FTX CN3210	0.100	
		2	FTX CN3220	0.160	
		3	FTX CN3230	0.220	
		5	FTX CN3250	0.430	
<b>24 V power supply connection cables</b>	Fitted with two 7/8, 5-pin connectors, one at each end	0.6	FTX DP2206	0.150	
		1	FTX DP2210	0.190	
		2	FTX DP2220	0.310	
		5	FTX DP2250	0.750	
			Fitted with one 7/8, 5-pin connector, other end free	1.5	FTX DP2115
		3	FTX DP2130	0.430	
		5	FTX DP2150	0.700	
<b>Connectors</b>	M12 male, 5-pin, A encoded	–	FTX CN12M5	0.050	
	M12 female, 5-pin, A encoded	–	FTX CN12F5	0.050	
<b>Line terminator (for end of bus)</b>	Fitted with one M12 connector	–	FTX CNTL12	0.010	
<b>T-connector for power supply</b>	Fitted with two 7/8, 5-pin connectors	–	FTX CNCT1	0.100	
<b>For Profibus DP bus</b>					
<b>Bus connection cables</b>	Fitted with 2 straight M12, 5-pin connectors, one at each end	0.3	FTX DP1203	0.040	
		0.6	FTX DP1206	0.070	
		1	FTX DP1210	0.100	
		2	FTX DP1220	0.160	
		3	FTX DP1230	0.220	
			5	FTX DP1250	0.430
	Fitted with 2 elbowed M12, 5-pin connectors, one at each end	0.3	FTX DP3203	0.040	
		0.6	FTX DP3206	0.070	
		1	FTX DP3210	0.100	
		2	FTX DP3220	0.160	
3		FTX DP3230	0.220		
		5	FTX DP3250	0.430	
<b>24 V power supply connection cables</b>	Fitted with two 7/8, 5-pin connectors, one at each end	0.6	FTX DP2206	0.150	
		1	FTX DP2210	0.190	
		2	FTX DP2220	0.310	
		5	FTX DP2250	0.750	
			Fitted with one 7/8, 5-pin connector, other end free	1.5	FTX DP2115
		3	FTX DP2130	0.430	
		5	FTX DP2150	0.700	
<b>Connectors</b>	M12 male, 5-pin, B encoded	–	FTX DP12M5	0.050	
	M12 female, 5-pin, B encoded	–	FTX DP12F5	0.050	
<b>Line terminator (for end of bus)</b>	Fitted with one M12 connector	–	FTX DPTL12	0.010	
<b>T-connector for power supply</b>	Fitted with two 7/8, 5-pin connectors	–	FTX CNCT1	0.100	
<b>Cables</b>	Free at both ends	100	TSX PBSCA100	–	
		400	TSX PBSCA400	–	
<b>For INTERBUS bus</b>					
<b>Cables with connectors for bus and power supply</b>	Fitted with 2 sets of connectors	0.6	FTX IB1206	0.250	
		1	FTX IB1210	0.400	
		2	FTX IB1220	0.650	
		5	FTX IB1250	–	
<b>Cable gland</b>	M16 x 1.5 (set of 2)	–	FTX CPE10	0.020	

# IP 67 monobloc I/O splitter boxes for fieldbuses

Advantys, FTB splitter boxes



Separate components			
Description	Composition	Reference	Weight kg
<b>For all bus types</b>			
<b>Connectors</b>	7/8 male, 5-pin	<b>FTX C78M5</b>	0.050
	7/8 female, 5-pin	<b>FTX C78F5</b>	0.050
<b>Sealing plugs</b>	For M8 connector (lot of 10)	<b>FTX CM08B</b>	0.100
	For M12 connector (lot of 10)	<b>FTX CM12B</b>	0.100
	For 7/8 connector	<b>FTX C78B</b>	0.020
<b>Y-connectors</b>	Connection of 2 x M8 connectors to M12 connector on splitter box	<b>FTX CY1208</b>	0.020
	Connection of 2 x M12 connectors to M12 connector on splitter box	<b>FTX CY1212</b>	0.030
<b>Diagnostics adaptor</b>	Fitted with two M12 connectors	<b>FTX DG12</b>	0.020
<b>Marker labels</b>	For plastic splitter boxes (lot of 10)	<b>FTX BLA10</b>	0.010
	For metal splitter boxes (lot of 10)	<b>FTX MLA10</b>	0.010
<b>CD-ROM</b>	Configuration files, technical manuals and operating instructions	<b>FTX ES00</b>	0.050

# IP 67 monobloc I/O splitter boxes for fieldbuses

Advantys, FTB splitter boxes

FTB 1CN●●●P0, FTB 1DN●●●P0, FTB 1DP●●●P0

FTB 1IB●●●P1

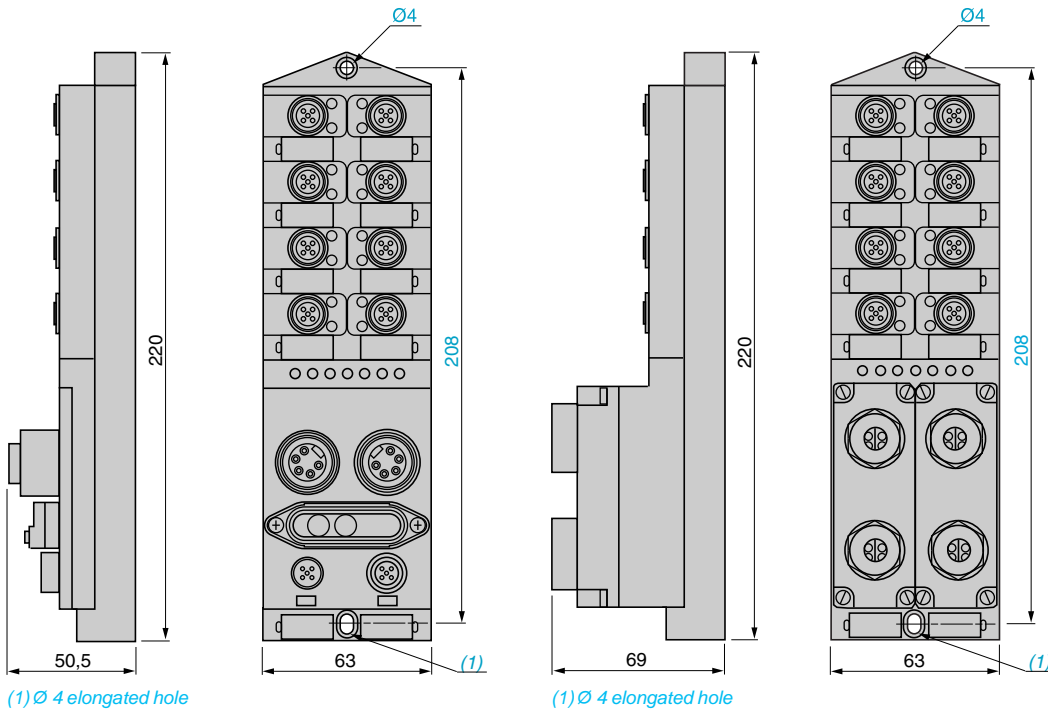

FTB 1CN●●●●●M0, FTB 1DN●●●●●M0, FTB 1DP●●●●●M0

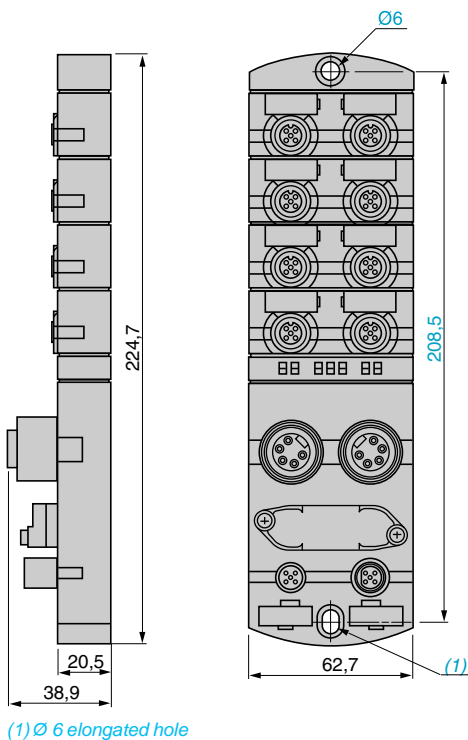

FTX CY1208

FTX CY1212

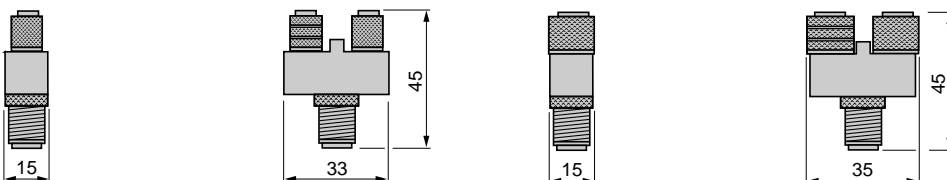

Presentation, functions:  
pages 14500/2 and 14500/3

Description, configuration:  
pages 14500/6 to 14500/12

Characteristics:  
pages 14500/14 and 14500/15

References:  
pages 14500/16 to 14500/18

**Sensor/actuator connection**

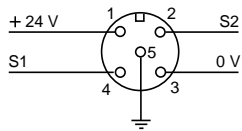

M12 female connector

**Y-constructor connection**

FTX CY1208

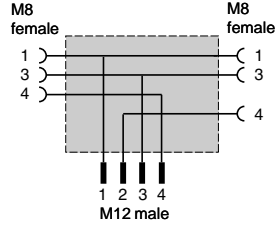

FTX CY1212

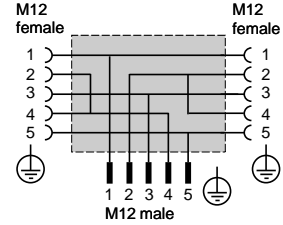

**CANopen and DeviceNet buses**

**Supply to splitter box**

Supply input

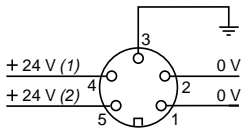

7/8 male connector

Supply output

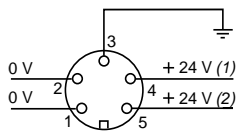

7/8 female connector

**Bus input/Bus output**

Bus input

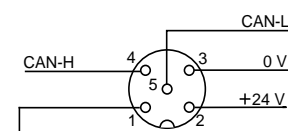

M12 male connector

Bus output

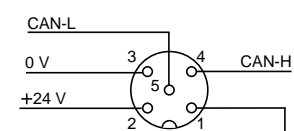

M12 female connector

(1) Supply to splitter box and sensors.  
(2) Supply to actuators.

**Profibus DP bus**

**Supply to splitter box**

Supply input

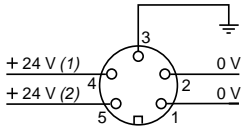

7/8 male connector

Supply output

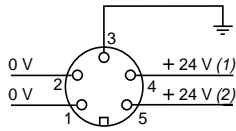

7/8 female connector

**Bus input/Bus output**

Bus input

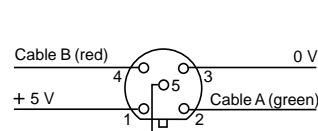

M12 male connector

Bus output

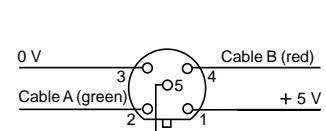

M12 female connector

(1) Supply to splitter box and sensors.  
(2) Supply to actuators.

**Note:** connectors linked to shielding.

# IP 67 monobloc I/O splitter boxes for fieldbuses

Advantys, FTB splitter boxes

**INTERBUS bus**

**Connections to splitter box**



**Supply to splitter box**

**1 Supply input**

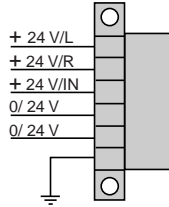

**2 Supply output**

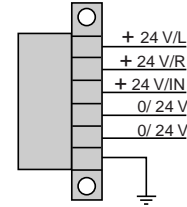

**Bus input/Bus output**

**3 Local bus, bus input**

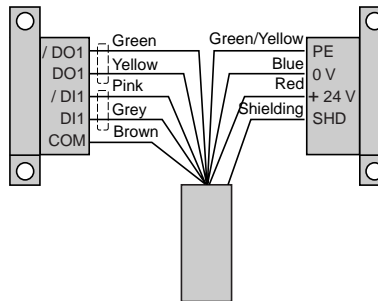

**3 Main bus, bus input**

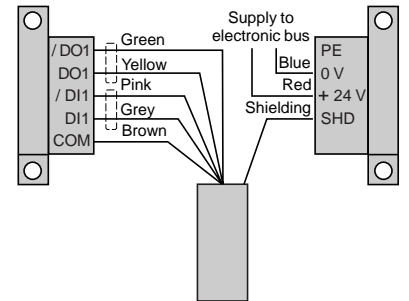

**4 Local bus, bus output**

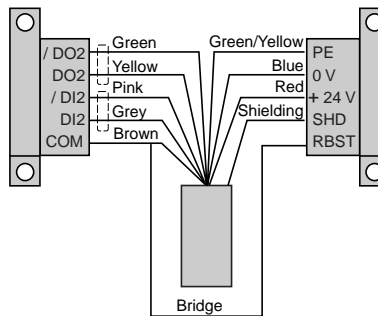

**4 Main bus, bus output**

