

Modicon M258

Logic Controller Hardware Guide

04/2012

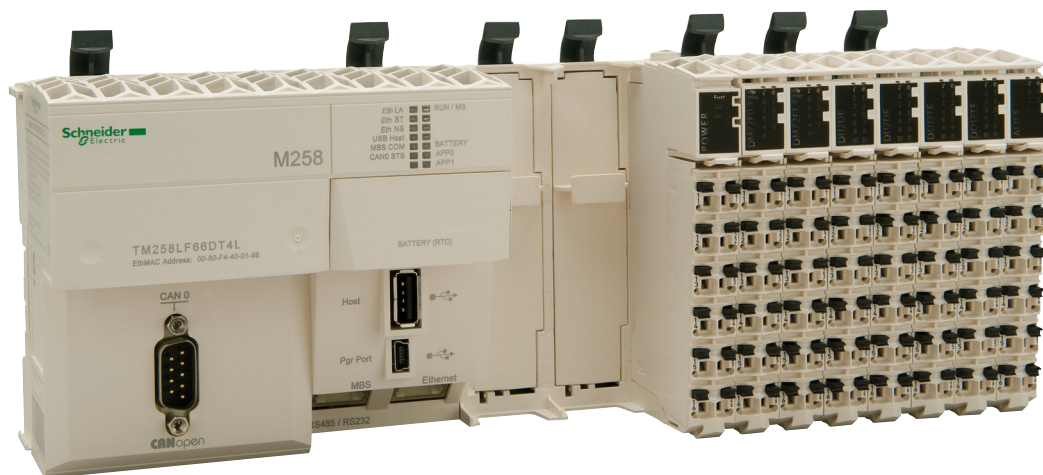

The information provided in this documentation contains general descriptions and/or technical characteristics of the performance of the products contained herein. This documentation is not intended as a substitute for and is not to be used for determining suitability or reliability of these products for specific user applications. It is the duty of any such user or integrator to perform the appropriate and complete risk analysis, evaluation and testing of the products with respect to the relevant specific application or use thereof. Neither Schneider Electric nor any of its affiliates or subsidiaries shall be responsible or liable for misuse of the information contained herein. If you have any suggestions for improvements or amendments or have found errors in this publication, please notify us.

No part of this document may be reproduced in any form or by any means, electronic or mechanical, including photocopying, without express written permission of Schneider Electric.

All pertinent state, regional, and local safety regulations must be observed when installing and using this product. For reasons of safety and to help ensure compliance with documented system data, only the manufacturer should perform repairs to components.

When devices are used for applications with technical safety requirements, the relevant instructions must be followed.

Failure to use Schneider Electric software or approved software with our hardware products may result in injury, harm, or improper operating results.

Failure to observe this information can result in injury or equipment damage.

© 2012 Schneider Electric. All rights reserved.

Table of Contents



	Safety Information	5
	About the Book	7
Chapter 1	TM5 System General Rules for Implementing	13
	Installation Requirements	14
	Wiring Rules and Recommendations	17
	Environmental Characteristics	23
Chapter 2	Modicon M258 Logic Controller Features	27
	About the Modicon M258 Logic Controller	28
	Controller Description	30
	Controller Common Characteristics	31
	Real Time Clock (RTC)	34
Chapter 3	Modicon M258 Logic Controller Installation	39
	First Startup	39
Chapter 4	TM258LD42DT	41
	General Description	42
	Characteristics of the Controller Power Distribution Module	46
Chapter 5	TM258LD42DT4L	49
	General Description	50
	Characteristics of the Controller Power Distribution Module	54
Chapter 6	TM258LF42DT••	57
	General Description	58
	Characteristics of the Controller Power Distribution Module	62
Chapter 7	TM258LF42DT4L••	65
	General Description	66
	Characteristics of the Controller Power Distribution Module	70
Chapter 8	TM258LF66DT4L••	73
	General Description	74
	Characteristics of the Controller Power Distribution Module	78
Chapter 9	TM258LF42DR••	81
	General Description	82
	Characteristics of the Controller Power Distribution Module	86

Chapter 10	Power Distribution Wiring Diagram	89
	Wiring Diagram for External Power Supplies	89
Chapter 11	Integrated Communication Ports	91
	Ethernet Port	92
	CAN Port	95
	USB Programming Port	99
	USB Host Port	101
	Serial Line Port	103
Chapter 12	PCI Slots	107
	PCI Slots	107
Chapter 13	Embedded Expert I/O	109
	Expert I/O	110
	Fast Inputs Characteristics	115
	Regular Inputs	118
	Fast Outputs	120
Chapter 14	Embedded Regular I/O	123
	Digital DI6DE	124
	Digital DI12DE	127
	Digital DO12TE	131
	Analog AI4LE	136
	Relay DO6RE	141
Chapter 15	Connecting the Modicon M258 Logic Controller to a PC	147
	Connecting the Controller to a PC	147
Glossary	151
Index	159

Safety Information

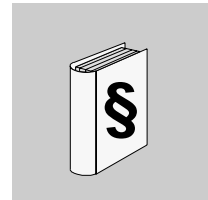

Important Information

NOTICE

Read these instructions carefully, and look at the equipment to become familiar with the device before trying to install, operate, or maintain it. The following special messages may appear throughout this documentation or on the equipment to warn of potential hazards or to call attention to information that clarifies or simplifies a procedure.



The addition of this symbol to a Danger safety label indicates that an electrical hazard exists, which will result in personal injury if the instructions are not followed.



This is the safety alert symbol. It is used to alert you to potential personal injury hazards. Obey all safety messages that follow this symbol to avoid possible injury or death.

DANGER

DANGER indicates an imminently hazardous situation which, if not avoided, **will result in** death or serious injury.

WARNING

WARNING indicates a potentially hazardous situation which, if not avoided, **can result in** death or serious injury.

 **CAUTION**

CAUTION indicates a potentially hazardous situation which, if not avoided, **can result in** minor or moderate injury.

NOTICE

NOTICE is used to address practices not related to physical injury.

PLEASE NOTE

Electrical equipment should be installed, operated, serviced, and maintained only by qualified personnel. No responsibility is assumed by Schneider Electric for any consequences arising out of the use of this material.

A qualified person is one who has skills and knowledge related to the construction and operation of electrical equipment and its installation, and has received safety training to recognize and avoid the hazards involved.

About the Book

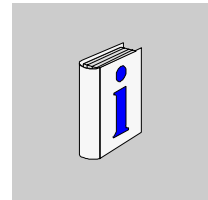

At a Glance

Document Scope

The purpose of this document is to:

- show you how to install and operate your controller,
- show you how to connect the controller to a programming device equipped with SoMachine software
- help you understand how to interface the controller with I/O modules, HMI and other devices
- help you become familiar with the controller features.

NOTE: Read and understand this document and all related documents (*see page 8*) before installing, operating or maintaining your controller.

The users should read through the entire document to understand all its features.

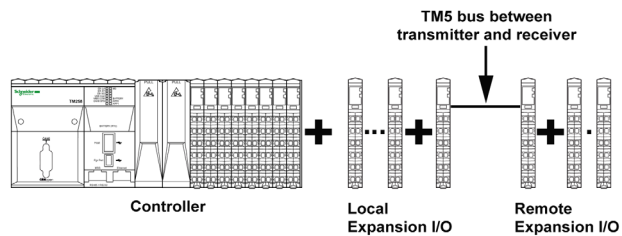

Validity Note

This document has been updated with the release of SoMachine V3.1.

The technical characteristics of the device(s) described in this manual also appear online. To access this information online:

Step	Action
1	Go to the Schneider Electric home page <i>www.schneider-electric.com</i> .
2	In the Search box type the model number of a product or the name of a product range. <ul style="list-style-type: none">• Do not include blank spaces in the model number/product range.• To get information on a grouping similar modules, use asterisks (*).
3	If you entered a model number, go to the Product datasheets search results and click on the model number that interests you. If you entered the name of a product range, go to the Product Ranges search results and click on the product range that interests you.
4	If more than one model number appears in the Products search results, click on the model number that interests you.
5	Depending on the size of your screen, you may need to scroll down to see the data sheet.
6	To save or print a data sheet as a .pdf file, click Download XXX product datasheet .

The characteristics presented in this manual should be the same as those that appear online. In line with our policy of constant improvement we may revise content over time to improve clarity and accuracy. In the event that you see a difference between the manual and online information, use the online information as your reference.

Related Documents

Title of Documentation	Reference Number
Modicon M258 Logic Controller Programming Guide	EIO0000000402 (ENG); EIO0000000403 (FRE); EIO0000000404 (GER); EIO0000000405 (SPA); EIO0000000406 (ITA); EIO0000000407 (CHS)
Modicon Flexible TM5 System - System Planning and Installation Guide	EIO0000000426 (ENG); EIO0000000427 (FRE); EIO0000000428 (GER); EIO0000000429 (SPA); EIO0000000430 (ITA); EIO0000000431 (CHS)

Modicon TM5 Digital I/O Modules Hardware Guide	EIO0000000450 (ENG); EIO0000000451 (FRE); EIO0000000452 (GER); EIO0000000453 (SPA); EIO0000000454 (ITA); EIO0000000455 (CHS)
Modicon TM5 Analog I/O Modules Hardware Guide	EIO0000000444 (ENG); EIO0000000445 (FRE); EIO0000000446 (GER); EIO0000000447 (SPA); EIO0000000448 (ITA); EIO0000000449 (CHS)
Modicon TM5 Expert (High Speed Counter) Modules Hardware Guide	EIO0000000462 (ENG); EIO0000000463 (FRE); EIO0000000464 (GER); EIO0000000465 (SPA); EIO0000000466 (ITA); EIO0000000467 (CHS)
Modicon TM5 Transmitter and Receiver Modules Hardware Guide	EIO0000000468 (ENG); EIO0000000469 (FRE); EIO0000000470 (GER); EIO0000000471 (SPA); EIO0000000472 (ITA); EIO0000000473 (CHS)
TM5 PCI Communication Modules Hardware Guide	EIO0000000474 (ENG); EIO0000000475 (FRE); EIO0000000476 (GER); EIO0000000477 (SPA); EIO0000000478 (ITA); EIO0000000479 (CHS)
Transparent Ready User Guide	31006929 02 (ENG); 31006930 02 (FRE); 31006931 02 (GER); 31006932 02 (SPA)
Quantum Ethernet User Guide for NOE-211/251	840 USE 107 00 (ENG); 840 USE 107 01 (FRE); 840 USE 107 02 (GER); 840 USE 107 03 (SPA)
Modicon M258 Logic Controller Instruction Sheet	BBV56040

You can download these technical publications and other technical information from our website at www.schneider-electric.com.

Product Related Information

DANGER

HAZARD OF ELECTRIC SHOCK, EXPLOSION OR ARC FLASH

- Disconnect all power from all equipment including connected devices prior to removing any covers or doors, or installing or removing any accessories, hardware, cables, or wires except under the specific conditions specified in the appropriate hardware guide for this equipment.
- Always use a properly rated voltage sensing device to confirm the power is off where and when indicated.
- Replace and secure all covers, accessories, hardware, cables, and wires and confirm that a proper ground connection exists before applying power to the unit.
- Use only the specified voltage when operating this equipment and any associated products.

Failure to follow these instructions will result in death or serious injury.

DANGER

EXPLOSIVE POTENTIAL

- Only use this equipment in non-hazardous locations, or in locations that comply with Class I, Division 2, Groups A, B, C and D.
- Do not substitute components which would impair compliance to Class I Division 2.
- Do not connect or disconnect equipment unless power has been removed or the location is known to be non-hazardous.

Failure to follow these instructions will result in death or serious injury.

WARNING

LOSS OF CONTROL

- The designer of any control scheme must consider the potential failure modes of control paths and, for certain critical control functions, provide a means to achieve a safe state during and after a path failure. Examples of critical control functions are emergency stop and overtravel stop, power outage and restart.
- Separate or redundant control paths must be provided for critical control functions.
- System control paths may include communication links. Consideration must be given to the implications of unanticipated transmission delays or failures of the link.
- Observe all accident prevention regulations and local safety guidelines.¹
- Each implementation of this equipment must be individually and thoroughly tested for proper operation before being placed into service.

Failure to follow these instructions can result in death, serious injury, or equipment damage.

¹ For additional information, refer to NEMA ICS 1.1 (latest edition), "Safety Guidelines for the Application, Installation, and Maintenance of Solid State Control" and to NEMA ICS 7.1 (latest edition), "Safety Standards for Construction and Guide for Selection, Installation and Operation of Adjustable-Speed Drive Systems" or their equivalent governing your particular location.

WARNING

UNINTENDED EQUIPMENT OPERATION

- Only use software approved by Schneider Electric for use with this equipment.
- Update your application program every time you change the physical hardware configuration.

Failure to follow these instructions can result in death, serious injury, or equipment damage.

User Comments

We welcome your comments about this document. You can reach us by e-mail at techcomm@schneider-electric.com.

TM5 System General Rules for Implementing



What's in this Chapter?

This chapter contains the following topics:

Topic	Page
Installation Requirements	14
Wiring Rules and Recommendations	17
Environmental Characteristics	23

Installation Requirements

Before Starting

Read and understand this chapter before beginning the installation of your TM5 System.

DANGER

HAZARD OF ELECTRIC SHOCK, EXPLOSION OR ARC FLASH

- Disconnect all power from all equipment including connected devices prior to removing any covers or doors, or installing or removing any accessories, hardware, cables, or wires except under the specific conditions specified in the appropriate hardware guide for this equipment.
- Always use a properly rated voltage sensing device to confirm the power is off where and when indicated.
- Replace and secure all covers, accessories, hardware, cables, and wires and confirm that a proper ground connection exists before applying power to the unit.
- Use only the specified voltage when operating this equipment and any associated products.

Failure to follow these instructions will result in death or serious injury.

NOTICE

ELECTROSTATIC DISCHARGE

- Store all components in their protective packaging until immediately before assembly.
- Never touch exposed conductive parts such as contacts or terminals.

Failure to follow these instructions can result in equipment damage.

Programming Considerations

WARNING

UNINTENDED EQUIPMENT OPERATION

- Only use software approved by Schneider Electric for use with this equipment.
- Update your application program every time you change the physical hardware configuration.

Failure to follow these instructions can result in death, serious injury, or equipment damage.

Operating Environment** DANGER****EXPLOSIVE POTENTIAL**

- Only use this equipment in non-hazardous locations, or in locations that comply with Class I, Division 2, Groups A, B, C and D.
- Do not substitute components which would impair compliance to Class I Division 2.
- Do not connect or disconnect equipment unless power has been removed or the location is known to be non-hazardous.

Failure to follow these instructions will result in death or serious injury.

 WARNING**UNINTENDED EQUIPMENT OPERATION**

Install and operate this equipment according to the environmental conditions described in the operating limits.

Failure to follow these instructions can result in death, serious injury, or equipment damage.

Installation Considerations

WARNING

UNINTENDED EQUIPMENT OPERATION

- Use appropriate safety interlocks where personnel and/or equipment hazards exist.
- Install and operate this equipment in an enclosure appropriately rated for its intended environment.
- Use the sensor and actuator power supplies only for supplying power to the sensors or actuators connected to the module.
- Power line and output circuits must be wired and fused in compliance with local and national regulatory requirements for the rated current and voltage of the particular equipment.
- Do not use this equipment in safety-critical machine functions.
- Do not disassemble, repair, or modify this equipment.
- Do not connect any wiring to reserved, unused connections, or to connections designated as Not Connected (N.C.).

Failure to follow these instructions can result in death, serious injury, or equipment damage.

NOTE: Schneider Electric recommends the use of UL-recognized and CSA approved JDYX2 or JDYX8 fuse types.

Wiring Rules and Recommendations

Introduction

There are several rules that must be followed when wiring the TM5 System.

Wiring Rules

**DANGER****HAZARD OF ELECTRIC SHOCK, EXPLOSION OR ARC FLASH**

- Disconnect all power from all equipment including connected devices prior to removing any covers or doors, or installing or removing any accessories, hardware, cables, or wires except under the specific conditions specified in the appropriate hardware guide for this equipment.
- Always use a properly rated voltage sensing device to confirm the power is off where and when indicated.
- Replace and secure all covers, accessories, hardware, cables, and wires and confirm that a proper ground connection exists before applying power to the unit.
- Use only the specified voltage when operating this equipment and any associated products.

Failure to follow these instructions will result in death or serious injury.

The following rules must be applied when wiring the TM5 System:

- I/O and communication wiring must be kept separate from the power wiring. Route these 2 types of wiring in separate cable ducting.
- Verify that the operating conditions and environment are within the specification values.
- Use proper wire sizes to meet voltage and current requirements.
- Use copper conductors only.
- Use twisted-pair, shielded cables for analog, expert or fast I/O and TM5 bus signals.
- Use twisted-pair, shielded cables for encoder, networks and field bus (CAN, serial, Ethernet).

⚠ WARNING

IMPROPER GROUNDING CAN CAUSE UNINTENDED EQUIPMENT OPERATION





- Use cables with insulated shielded jackets for analog I/O, fast I/O and communication signals.
- Ground shielded cables for analog I/O, fast I/O and communication signals at a single point ¹
- Always comply with local wiring requirements regarding grounding of cable shields.

Failure to follow these instructions can result in death, serious injury, or equipment damage.

NOTE: ¹Multipoint grounding is permissible if connections are made to an equipotential ground plane dimensioned to help avoid cable shield damage in the event of power system short circuit currents.

Refer to the section Grounding the TM5 System (*see Modicon TM5 / TM7 Flexible System, System Planning and Installation Guide*) to ground the shielded cables.

The table below provides the wire sizes to use with the removable spring terminal blocks:

 mm in.				
mm ²	0,08...2,5	0,25...2,5	0,25...1,5	2 x 0,25...2 x 0,75
AWG	28...14	24...14	24...16	2 x 24...2 x 18

⚠ DANGER

FIRE HAZARD

Use only the recommended wire sizes for I/O channels and power supplies.

Failure to follow these instructions will result in death or serious injury.

The spring clamp connectors of the terminal block are designed for only one wire or one cable end. Two wires to the same connector must be installed with a double wire cable end to help prevent loosening.

⚠ DANGER**LOOSE WIRING CAUSES ELECTRIC SHOCK**

Do not insert more than one wire per connector of the terminal block without a double wire cable end.

Failure to follow these instructions will result in death or serious injury.

Terminal Block

Plugging a terminal block into the incorrect electronic module can cause an electric shock or unintended operation of the application and/or damage the electronic module.

⚠ DANGER**UNINTENDED EQUIPMENT OPERATION OR ELECTRIC SHOCK**

Be sure to connect the terminal blocks to their designated location.

Failure to follow these instructions will result in death or serious injury.

NOTE: To help prevent a terminal block from being inserted incorrectly, clearly and uniquely code and label each terminal block and electronic module according to the instructions in *Coding the TM5 System (see Modicon TM5 / TM7 Flexible System, System Planning and Installation Guide)*.

Stress Relief Using Cable Tie

There are two methods to reduce the stress on cables:

- The terminal blocks (*see Modicon TM5 / TM7 Flexible System, System Planning and Installation Guide*) have slots to attach cable ties. A cable tie can be fed through this slot to secure cables and wires to reduce stress between them and the terminal block connections.
- After grounding the TM5 System via the TM2XMTGB grounding plate (*see Modicon TM5 / TM7 Flexible System, System Planning and Installation Guide*), wires can be bundled and fixed to the grounding plate tabs using wire ties to reduce stress on the cables.

The table below provides the size of the cable tie and shows the two methods to reduce the stress on the cables:

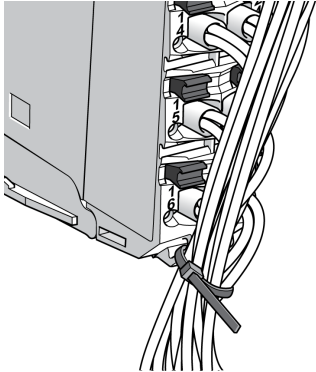
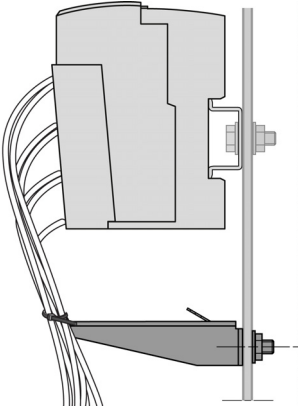
Cable Tie Size	Terminal block	TM2XMTGB Grounding plate
Thickness	1.2 mm (0.05 in.) maximum	1.2 mm (0.05 in.)
Width	4 mm (0.16 in.) maximum	2.5...3 mm (0.1...0.12 in.)
Mounting figure		

Protecting Outputs from Inductive Load Damage

Depending on the load, a protection circuit may be needed for the outputs on the controllers and certain modules. Inductive loads using DC voltages may create voltage reflections resulting in overshoot that will damage or shorten the life of output devices.

⚠ CAUTION
OUTPUT CIRCUIT DAMAGE DUE TO INDUCTIVE LOADS
Use an appropriate external protective circuit or device to reduce the risk of inductive direct current load damage.
Failure to follow these instructions can result in injury or equipment damage.

Relay outputs can support up to 240 Vac. Inductive damage to these types of outputs can result in welded contacts and loss of control. Each inductive load must be equipped with a protection device such as a peak limiter, RC circuit or flyback diode. Capacitive loads are not supported by these relays.

⚠ WARNING

RELAY OUTPUTS WELDED CLOSED

- Always protect relay outputs from inductive alternating current load damage using an appropriate external protective circuit or device.
- Do not connect relay outputs to capacitive loads.

Failure to follow these instructions can result in death, serious injury, or equipment damage.

Protective circuit A: this protection circuit can be used for both AC and DC load power circuits.

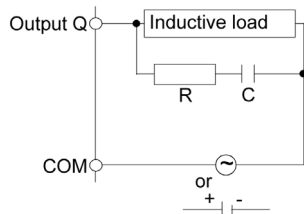

- C represents a value from 0.1 to 1 μF .
- R represents a resistor of approximately the same resistance value as the load.

Protective circuit B: this protection circuit can be used for DC load power circuits.

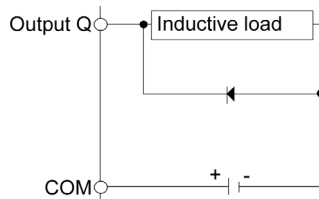

Use a diode with the following ratings:

- Reverse withstand voltage: power voltage of the load circuit x 10.
- Forward current: more than the load current.

Protective circuit C: this protection circuit can be used for both AC and DC load power circuits.

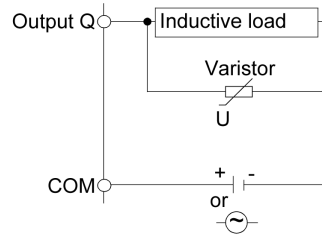

- In applications where the inductive load is switched on and off frequently and/or rapidly, ensure that the continuous energy rating (J) of the varistor exceeds the peak load energy by 20 % or more.

Environmental Characteristics

Introduction

The following information describes the system-wide environmental requirements and characteristics for the TM5 System.

The general environmental characteristics are common to all components of the TM5 System.

Enclosure Requirements

TM5 components are designed as Zone B, Class A industrial equipment according to IEC/CISPR Publication 11. If they are used in environments other than those described in the standard, or in environments that do not meet the specifications in this manual, your ability to meet electromagnetic compatibility requirements in the presence of conducted and/or radiated interference may be reduced.

All TM5 components meet European Community (CE) requirements for open equipment as defined by EN61131-2. You must install them in an enclosure designed for the specific environmental conditions and to minimize the possibility of unintended contact with hazardous voltages. Your enclosure should be constructed of metal to improve the electromagnetic immunity of your TM5 System. Your enclosure should have a keyed locking mechanism to minimize unauthorized access.

Environmental Characteristics

This equipment meets UL, CSA, GOST-R and c-Tick certifications and CE requirements as indicated in the table below. This equipment is intended for use in a Pollution Degree 2 industrial environment.

The table below provides the general environmental characteristics:

Characteristic	Specification	
This product is compliant with Europe RoHS recommendations and China RoHS regulations.		
		
Standard	IEC61131-2 ed. 3 2007	
Agencies	UL 508 CSA 22.2 No. 142-M1987 CSA 22.2 No. 213-M1987	
Ambient operating temperature	Horizontal installation	-10...60 °C (14...140 °F) ^{1, 3}
	Vertical installation	-10...50 °C (14...122 °F) ³
Storage temperature	-40...70 °C (-40...158 °F) ²	

Characteristic	Specification	
Relative humidity	5...95% (non-condensing)	
Degree of pollution	IEC60664	2
Degree of protection	IEC61131-2	IP20
Corrosion immunity	No	
Operating altitude	0...2,000 m (0...6,560 ft.)	
Storage altitude	0...3,000 m (0...9,842 ft.)	
Vibration resistance	Mounted on a DIN rail	3.5 mm (0.138 in.) fixed amplitude from 5...8.4 Hz 9.8 m/s ² (1 g _n) fixed acceleration from 8.4...150 Hz
Mechanical shock resistance	147 m/s ² (15 g _n) for a duration of 11 ms	
Connection type	Removable spring terminal block	
Connector insertion/removal cycles	50	
Controller RTC Battery Type	Renata Type CR2477 (replaceable)	
<p>Note:</p> <ol style="list-style-type: none"> 1 Some devices have temperature operating restrictions that require de-rating between 55 °C and 60 °C (131 °F and 140 °F), and may be subject to other possible restrictions. See the specific characteristics for your electronic module. 2 All controllers with a battery installed must be stored in the temperature range between -30...70 °C (-22...158 °F). 3 For compliance to Class I, Div 2 environment ratings, do not operate this device in locations with ambient temperatures less than 0 °C (32° F). 		

NOTE: Replacement of the battery in the controllers other than with the type specified in this documentation may present a risk of fire or explosion. For more important information concerning the procedures for replacing lithium batteries, please consult the hardware guide for your controller.

⚠ WARNING
IMPROPER BATTERY CAN PROVOKE FIRE OR EXPLOSION
Replace battery only with identical type: Renata Type CR2477M.
Failure to follow these instructions can result in death, serious injury, or equipment damage.

Electromagnetic Susceptibility

The table below provides the TM5 System electromagnetic susceptibility specifications:

Characteristic	Specification	Range
Electrostatic discharge	IEC/EN 61000-4-2	8 kV (air discharge) 4 kV (contact discharge)
Electromagnetic fields	IEC/EN 61000-4-3	10 V/m (80 MHz...2 GHz) 1 V/m (2...2.7 GHz)
Fast transients burst	IEC/EN 61000-4-4	Power lines: 2 kV I/O: 1 kV Shielded cable: 1 kV Repetition rate: 5 and 100 KHz
Surge immunity 24 Vdc circuit	IEC/EN 61000-4-5	1 kV in common mode 0.5 kV in differential mode
Surge immunity 230 Vac circuit		2 kV in common mode 1 kV in differential mode
Induced electromagnetic field	IEC/EN 61000-4-6	10 V _{eff} (0.15...80 MHz)
Conducted emission	EN 55011 (IEC/CISPR11)	150...500 kHz, quasi peak 79 dB μ V
		500 kHz...30 MHz, quasi peak 73 dB μ V
Radiated emission	EN 55011 (IEC/CISPR11)	30...230 MHz, 10 m@40 dB μ V/m
		230 MHz...1 GHz, 10 m@47 dB μ V/m

Modicon M258 Logic Controller Features

2

Introduction

This chapter describes the features of the Modicon M258 Logic Controller.

What's in this Chapter?

This chapter contains the following topics:

Topic	Page
About the Modicon M258 Logic Controller	28
Controller Description	30
Controller Common Characteristics	31
Real Time Clock (RTC)	34

About the Modicon M258 Logic Controller

Overview

The Schneider Electric Modicon M258 Logic Controller is a controller with a variety of powerful features. It can control a wide range of applications.

The Software configuration is described in the SoMachine Programming Guide.

Key Features

The SoMachine software supports the following IEC61131-3 programming languages for use with these controllers:

- IL: Instruction List
- LD: Ladder Diagram
- ST: Structured Text
- FBD: Function Block Diagram
- SFC: Sequential Function Chart
- CFC: Continuous Function Chart

All controllers support the following fieldbuses and network capabilities:

- CANopen Master
- Ethernet
- Serial Line

All controllers support the following functions and I/O types:

- Expert functions (counting, reflex outputs...)
- Embedded I/Os

All controllers support up to 21 application program tasks with the following limits:

- 4 cyclic tasks: one is configured by default (MAST)
- 1 freewheeling task
- 8 software event driven tasks
- 8 hardware event driven tasks

Controller Range

	PCI	CAN	USB A	USB Pgr	Ethernet	Serial Line
TM258LD42DT <i>(see page 41)</i>	0	0	1	1	1	1
TM258LD42DT4L <i>(see page 49)</i>	2	0	1	1	1	1
TM258LF42DT** <i>(see page 57)</i>	0	1	1	1	1	1
TM258LF42DT4L** <i>(see page 65)</i>	2	1	1	1	1	1

	PCI	CAN	USB A	USB Pgr	Ethernet	Serial Line
TM258LF66DT4L** (see page 73)	2	1	1	1	1	1
TM258LF42DR** (see page 81)	2	1	1	1	1	1

	Embedded Expert I/O				Embedded Regular I/O			
		Fast Inputs	Fast Outputs	Regular Inputs		Digital Inputs	Digital Outputs	Analog Inputs
TM258LD42DT (see page 41)	2x	5	2	2	1x	12	12	0
TM258LD42DT4L (see page 49)	2x	5	2	2	1x	12	12	4
TM258LF42DT** (see page 57)	2x	5	2	2	1x	12	12	0
TM258LF42DT4L** (see page 65)	2x	5	2	2	1x	12	12	4
TM258LF66DT4L** (see page 73)	2x	5	2	2	2x	12	12	4
TM258LF42DR** (see page 81)	2x	5	2	2	2x	6	6 Relays	0

Controller Description

Overview

The Modicon M258 Logic Controller and its range are described below.

Physical Description

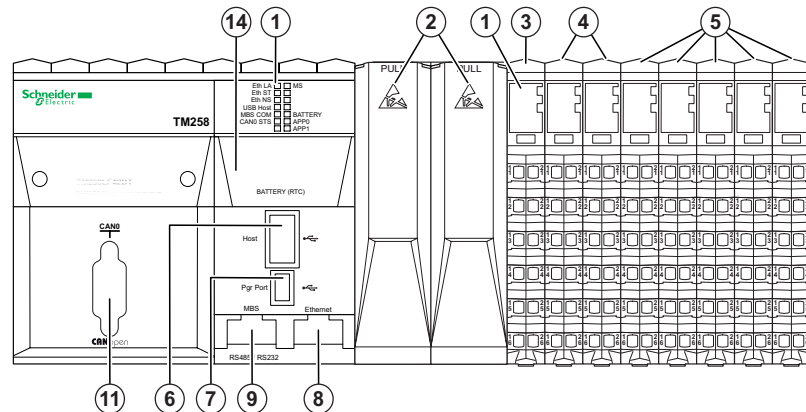

- 1 LED Status
- 2 PCI slots (depending on the controller reference)
- 3 Controller Power Distribution Module (CPDM)
- 4 Expert I/O (Embedded)
- 5 Regular I/O (Embedded)
- 6 USB A port (Host)
- 7 USB programming port (Pgr Port)
- 8 Ethernet port (Ethernet)
- 9 Serial Line port (MBS)
- 11 CANopen port (CAN0)
- 14 Real Time Clock battery (Battery (RTC))

Controller Common Characteristics

Overview

The common characteristics for all the Modicon M258 Logic Controllers are described below.

Programming

Use the SoMachine software to program the controller.

WARNING

UNINTENDED EQUIPMENT OPERATION

- Only use software approved by Schneider Electric for use with this equipment.
- Update your application program every time you change the physical hardware configuration.

Failure to follow these instructions can result in death, serious injury, or equipment damage.

SoMachine is a professional, efficient and open OEM software solution that helps you develop, configure and commission the entire machine in a single environment (including logic, motor control, HMI and related network automation functions).

SoMachine allows you to program and commission the entire range of elements in Schneider Electric's Flexible Machine Control (FMC) platform and helps you optimize the control solution for each machine's requirements.

All information about SoMachine is included in the global SoMachine software help system.

Memory

The following table describes the different kinds of memory:

Memory type	Size	Used
RAM	64 Mbytes	To execute the application.
Flash	128 Mbytes	To save program and data in case of a power outage.

Embedded Communication features

The four kinds of ports on the controller front panel are:

- Ethernet port
- CAN ports
- USB ports
- Serial Line Port

For more details, refer to the chapter Integrated Communication Ports (*see page 91*).

PCI

The communication electronic module range includes:

- RS232 connection electronic modules
- RS485 connection electronic modules (for Serial Line and Profibus DP)

Controller Power Distribution Module (CPDM)

The controller power distribution module is divided into 3 power circuits:

- 24 Vdc Embedded expert modules power
- 24 Vdc Main power (for controller, fieldbus and TM5 power bus)
- 24 Vdc I/O power segment

There is no configuration necessary for this module.

Embedded Expert Input/Output

The controller base provides:

- 2 Embedded Expert I/O modules (DM72F0 and DM72F1) each with:
 - 5 fast inputs
 - 2 regular inputs
 - 2 fast outputs

Embedded Regular Input/Output

The Embedded Regular I/O may include, depending on the controller range:

- digital input electronic modules
- digital output electronic modules
- analog input electronic modules
- relay output electronic modules

Every digital and analog electronic module channel has a status LED.

Expansion Modules

You can expand the number of I/O for your controller by adding expansion I/O slices. The following table lists the different types of electronic modules available to create expansion I/O slices:

Reference	Description
TM5C**	Compact I/O modules (see <i>Modicon TM5, Compact I/O Modules, Hardware Guide</i>)
TM5SD**	Digital modules (see <i>Modicon TM5, Digital I/O Modules, Hardware Guide</i>)
TM5SA**	Analog modules (see <i>Modicon TM5, Analog I/O Modules, Hardware Guide</i>)
TM5SPS**	Power distribution modules (see <i>Modicon TM5 / TM7 Flexible System, System Planning and Installation Guide</i>)
TM5SE**	Specialized expansion modules (see <i>Modicon TM5, Expert (High Speed Counter) Modules, Hardware Guide</i>)
TM5SBE**	Transmitter and receiver modules (see <i>Modicon TM5, Transmitter and Receiver Modules, Hardware Guide</i>)
TM5SPD**	Common Distribution Module (see <i>Modicon TM5 / TM7 Flexible System, System Planning and Installation Guide</i>)
TM5SD000	Dummy module (see <i>Modicon TM5 / TM7 Flexible System, System Planning and Installation Guide</i>)

Real Time Clock (RTC)

Overview

These controllers include an RTC to provide system date and time information, and to support related functions requiring a real-time clock. To continue to keep time when power is off, a non-rechargeable but replaceable battery is delivered with the controller. A battery LED indicates if the battery charge is low or the battery absent.

The following table shows how RTC drift is managed:

RTC characteristics	Description
RTC drift	Less than 30 seconds per month without any user calibration at 25° C (77° F)
RTC drift with user logic assistance	Less than or equal to 6 seconds per month with user calibration (<i>see Modicon M258 Logic Controller, System Functions and Variables, Modicon M258 PLCSystem Library Guide</i>) through application software when the controller is in RUN mode.

RTC Battery

The controller has one RTC battery.

In the event of a power outage, the backup battery will retain the time of the controller.

The table below shows the characteristics of the RTC battery:

Use	In the event of a transient power outage, the battery will power the RTC
Backup Time	At least 1.5 years at 45° C max (113° F). At higher temperatures, the time is reduced
Battery Monitoring Features	Yes
Replaceable	Yes
Controller RTC Battery Type	Type BBCV2, Renata Type CR2477M

Installing and Replacing the RTC battery

While lithium batteries are preferred due to their slow discharge and long life, they can present hazards to personnel, equipment and the environment, and must be handled properly. For more important information concerning the procedures for replacing lithium batteries, please consult the hardware guide for your controller.

DANGER

EXPLOSION, FIRE, OR CHEMICAL HAZARD

Follow these instructions for the lithium batteries:

- Replace with identical type.
- Follow all battery manufacturer's instructions.
- Remove all replaceable batteries before discarding unit.
- Recycle or properly dispose of used batteries.
- Protect battery from any potential short circuit.
- Do not recharge, disassemble, heat above 100 °C (212 °F), or incinerate.
- Use your hands or insulated tools to remove or replace the battery.
- Maintain proper polarity when inserting and connecting a new battery.

Failure to follow these instructions will result in death or serious injury.

To install or replace the RTC battery, follow these steps:

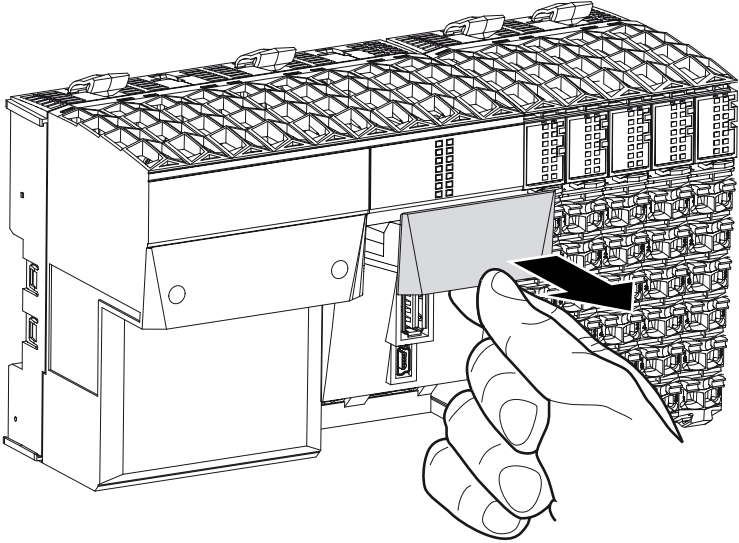
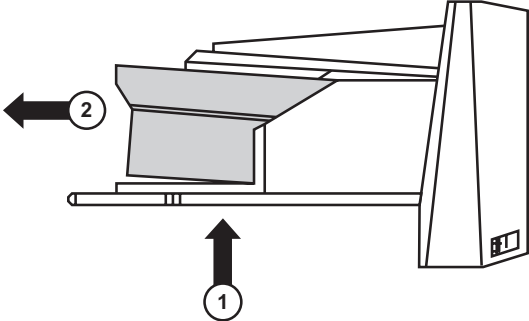
Step	Action
1	Power off your controller.
2	<p>Slide out the battery holder of the controller:</p> 
3	<p>Remove the battery from the battery holder:</p> 

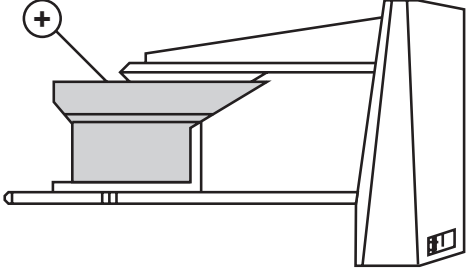
Step	Action
4	Insert the new battery into the battery holder in accordance with the polarity markings on the battery: 
5	Replace the battery holder on the controller and verify that the latch clicks into place.
6	Power up your Modicon M258 Logic Controller. NOTE: If you do not power up your Modicon M258 Logic Controller immediately, the external backup battery life might be significantly reduced.
7	Set the internal clock. For further details on the internal clock, please refer to RTC Library (see <i>Modicon M258 Logic Controller, System Functions and Variables, Modicon M258 PLCSystem Library Guide</i>).

NOTE: Replacement of the battery in the controllers other than with the type specified in this documentation may present a risk of fire or explosion. For more important information concerning the procedures for replacing lithium batteries, please consult the hardware guide for your controller.

⚠ WARNING

IMPROPER BATTERY CAN PROVOKE FIRE OR EXPLOSION

Replace battery only with identical type: Renata Type CR2477M.

Failure to follow these instructions can result in death, serious injury, or equipment damage.

Modicon M258 Logic Controller Installation

3

First Startup

Overview

This procedure helps you through the installation and startup of your controller.

Startup Procedure

Step	Action	Comment
1	Unpack your controller and check the contents of the package.	Contents of package: Instruction Sheet, Controller, Terminal blocks to be mounted on the controller, RTC battery in a separate bag
2	Choose an appropriate cabinet and DIN rail and install them.	Refer to the Modicon Flexible TM5 System - System Planning and Installation Guide (<i>see Modicon TM5 / TM7 Flexible System, System Planning and Installation Guide</i>).
3	Plug your controller on the DIN rail.	
4	Connect your PCI expansion modules to the controller.	Refer to the PCI Slots (<i>see page 107</i>).
5	Connect the expansion I/O slices (optional).	Refer to the Modicon Flexible TM5 System - System Planning and Installation Guide (<i>see Modicon TM5 / TM7 Flexible System, System Planning and Installation Guide</i>).
6	Connect your devices to the inputs and outputs.	Refer to Modicon TM5 Analog I/O Modules Hardware Guide (<i>see Modicon TM5, Analog I/O Modules, Hardware Guide</i>) and Modicon TM5 Digital I/O Modules Hardware Guide (<i>see Modicon TM5, Digital I/O Modules, Hardware Guide</i>).

Step	Action	Comment
7	Connect the external 24 Vdc power source(s) Controller Power Distribution Module (CPDM) and any optional Power Distribution Modules (PDM).	Refer to CPDM Wiring Diagram (<i>see page 89</i>).
8	Connect your controller to your PC. NOTE: SoMachine must be installed on your PC.	Refer to Connecting the Controller to a PC (<i>see page 147</i>).
9	Verify all connections.	—
10	Turn on power.	—
11	Login to your controller.	—
12	Create an application.	—
13	Load your application into the controller.	—
14	Create your boot application.	—
15	Run the application.	—

TM258LD42DT



4

Introduction

This chapter describes the TM258LD42DT controller.

What's in this Chapter?

This chapter contains the following topics:

Topic	Page
General Description	42
Characteristics of the Controller Power Distribution Module	46

General Description

Overview

The following figure describes the different components of the TM258LD42DT:

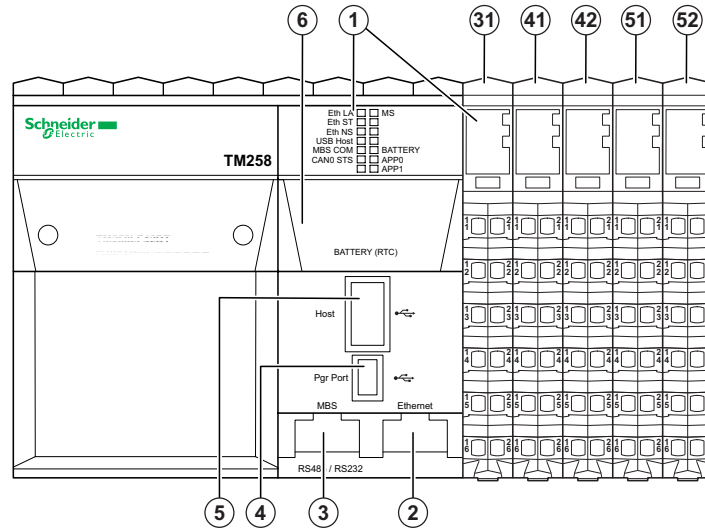

N°	Designation / Description	Refer to
1	LED status	Status LEDs (<i>see page 43</i>)
2	Ethernet port / Type RJ45	Ethernet Port (<i>see page 92</i>)
3	Serial line / Type RJ45 (RS232 or RS485)	Serial Line Port (<i>see page 103</i>)
4	USB programming port / For terminal connection to a programming PC (SoMachine)	USB Programming Port (<i>see page 99</i>)
5	USB host / For memory key management	USB Host Port (<i>see page 101</i>)
6	Battery	RTC Battery (<i>see page 34</i>)
31	Controller Power Distribution Module / For connecting external power supplies	Controller Power Distribution Module (<i>see page 32</i>)
41	Embedded Expert I/O modules / 5 fast inputs, 2 regular inputs, 2 fast outputs	Embedded Expert I/O (<i>see page 109</i>)
42		
51	Embedded Regular Input module / 12 digital inputs	Digital DI12DE (<i>see page 127</i>)
52	Embedded Regular Output module / 12 digital outputs	Digital DO12TE (<i>see page 131</i>)

Status LEDs

The following figure shows the LEDs on the front panel display:

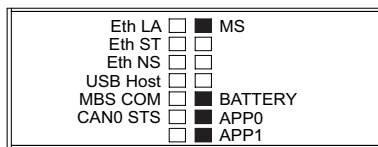

The following table describes the controller status LEDs:

Marking	Description	LED	
		Color	Description
MS	Module status	Green / Red	See MS status LED below
BATTERY	Battery status	Red	On when RTC battery needs to be replaced
APP0	Application LEDs	Green / Red	Managed by user application
APP1			

For further details on the following LEDs:

- Eth LA, Eth ST and Eth NS, please refer to Ethernet Port - Status LEDs (*see page 93*).
- USB Host, please refer to USB Host Port - Status LED (*see page 102*).
- MBS COM, please refer to Serial Line Port - Status LED (*see page 105*).
- CAN0 STS, please refer to CAN Port - Status LED (*see page 98*).

The following table describes the MS status LED:

Status LED	Controller State	Prg Port Communication	Application Execution
Flashing green / red	BOOTING	No	No
Flashing red	INVALID OS	Restricted	No
Single flash green	EMPTY	Yes	No
Green ON	RUNNING	Yes	Yes
3 flash green	RUNNING with Breakpoint	Yes	Restricted
Flashing green	STOPPED	Restricted	No
Single flash red	HALT	Yes	No
Rapid flashing red	REBOOT after a hardware error has been detected	Yes	No (Empty)
Red ON	HALT after system error detected	No	No

Status LED	Controller State	Prg Port Communication	Application Execution
OFF	No power	No	No
Green / with single flash red	RUNNING with external error detected Or different Boot Project Or no Boot Project	Yes	Yes
Flashing green / with single flash red	STOPPED with external error detected	Restricted	No

NOTE: For further details on controller states, refer to the Operating Mode discussion in the Programming Guide for your particular controller.

Controller States

The following table describes the controller states:

State	Description
BOOTING	The controller executes the boot firmware and its own internal self tests. It does not execute the application nor does it communicate. It then checks the checksum of the firmware and user application.
INVALID_OS	The Operating System is not valid. The controller can not execute an application. Communications are restricted.
EMPTY	The user application is not valid or a hardware error has been detected. The controller does not execute the application but it can communicate.
RUNNING	The controller executes the application.
STOPPED	The controller has a valid application that is stopped.
HALT	The controller has detected an application or system error and has ceased application execution.

NOTE: For further details on controller states, refer to the Operating Mode discussion in the Programming Guide for your particular controller.

Dimensions

The following figure describes the external dimensions of the controller:

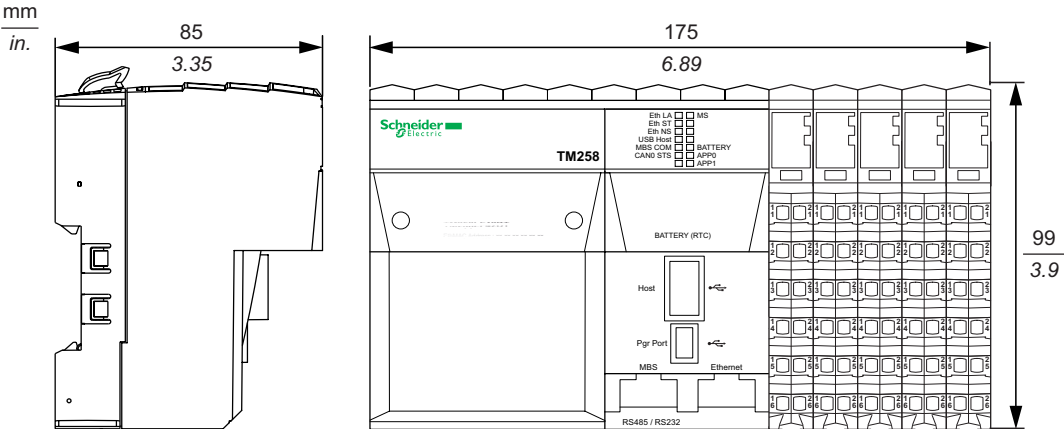

The following table describes the weight of the TM258LD42DT:

Weight	
TM258LD42DT	500 g (17.6 oz)

Characteristics of the Controller Power Distribution Module

The Controller Power Distribution Module (CPDM) has three 24 Vdc power connections:

- Main power (**Ctrl**)
- Expert I/O power (**Exp.**)
- 24 Vdc I/O Power Segment power (**I/O**)

The state of these three power connections is indicated by a set of LEDs on the CPDM:

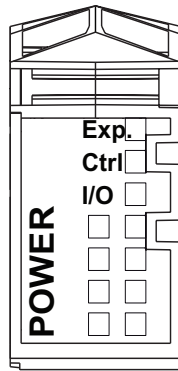

The following table describes the CPDM LED display:

LEDs	Color	Status	Description
Exp. (Expert I/O power)	Green	On	24 Vdc applied
Ctrl (Main power)	Green	On	24 Vdc applied
I/O (24 Vdc I/O Power Segment power)	Green	On	24 Vdc applied

The Main power serves the TM5 power bus, the Serial Line port, the USB port, any PCI modules that may be installed, and power for the controller electronics.

The Expert I/O power serves the Expert I/O module inputs and outputs, the power for the embedded Encoder port, and power for the Expert I/O module electronics.

The 24 Vdc I/O power segment power serves the Regular I/O modules inputs and outputs, as well as providing power to the first segment of the 24 Vdc I/O Power segment for any optional I/O slices of the local configuration.

CPDM Power Consumption Overview

The following table shows the power characteristics of the TM258LD42DT:

Rated voltage CPDM		24 Vdc	
Voltage range CPDM		20.4...28.8 Vdc	
Main power	Minimum current (no external loads)	0.3 A	
	Maximum current including the following loads:	0.8 A	
		Current for TM5 bus power when adding expansion modules	0...0.1 A
		Current for serial line when connected devices consume power	0...0.05 A
		Current for USB Host when connected devices consume power	0...0.1 A
	Inrush current	Time < 70 μ s	100 A max.
		70 ... 2000 μ s	3 A max.
Internal protection	No	see note 1	
Embedded Expert modules power	Minimum current (no external loads)	0.04 A	
	Maximum current including the following loads:	0.9 A	
		Current for Expert Inputs	0...0.1 A
		Current for Expert Outputs	0...0.8 A
	Inrush current	Time < 150 μ s	50 A max.
	Internal protection	No	see note 1
24 Vdc I/O power segment	Maximum current (depending on the modules on the segment)	10 A max.	
	Inrush current (depending on the modules on the segment)	Time < 500 μ s	25 A max.
	Internal protection	No	see note 1

¹ Add external fuse as specified in the wiring diagrams.

Refer to the chapter *Example 1: Current Consumed by a Local Configuration* (see *Modicon TM5 / TM7 Flexible System, System Planning and Installation Guide*) for further details on power consumption.

TM258LD42DT4L



5

Introduction

This chapter describes the TM258LD42DT4L controller.

What's in this Chapter?

This chapter contains the following topics:

Topic	Page
General Description	50
Characteristics of the Controller Power Distribution Module	54

General Description

Overview

The following figure shows the different components of the TM258LD42DT4L:

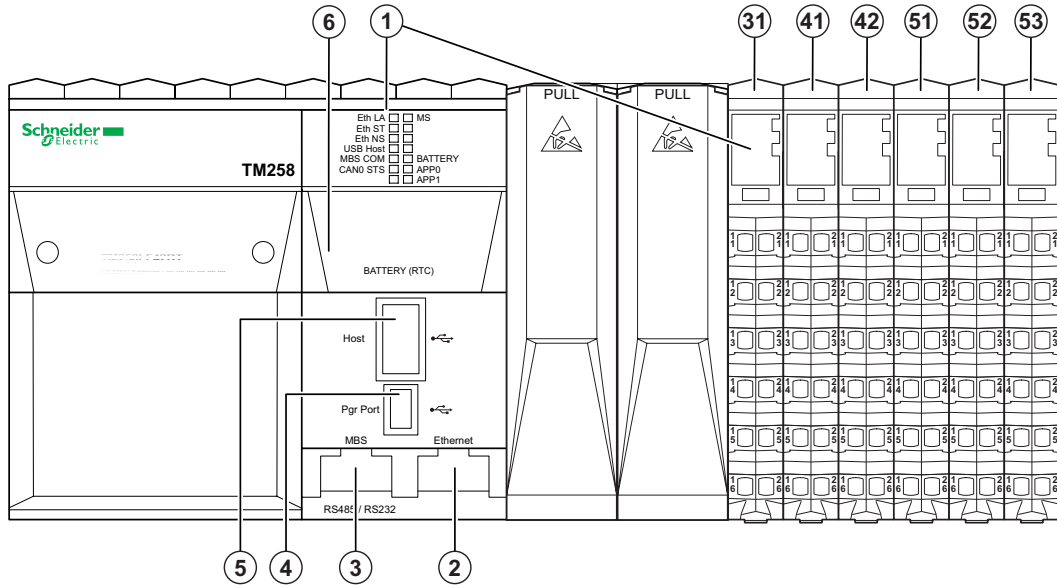

N°	Designation	Refer to
1	LED status	Status LEDs (<i>see page 51</i>)
2	Ethernet port / Type RJ45	Ethernet Port (<i>see page 92</i>)
3	Serial line / Type RJ45 (RS232 or RS485)	Serial Line Port (<i>see page 103</i>)
4	USB programming port / For terminal connection to a programming PC (SoMachine)	USB Programming Port (<i>see page 99</i>)
5	USB host / For memory key management	USB Host Port (<i>see page 101</i>)
6	Battery	RTC Battery (<i>see page 34</i>)
31	Controller Power Distribution Module / For connecting external power supplies	Controller Power Distribution Module (<i>see page 32</i>)
41	Embedded Expert I/O module / 5 fast inputs, 2 regular inputs, 2 fast outputs	Embedded Expert I/O (<i>see page 109</i>)
42		
51	Embedded Regular Input module / 12 digital inputs	Digital DI12DE (<i>see page 127</i>)
52	Embedded Regular Output module / 12 digital outputs	Digital DO12TE (<i>see page 131</i>)
53	Embedded Regular Input module / 4 analog inputs (12 bits)	Analog AI4LE (<i>see page 136</i>)

Status LEDs

The following figure shows the LEDs on the front panel display:

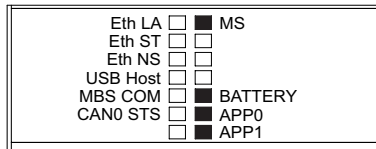

The following table describes the controller status LEDs:

Marking	Description	LED	
		Color	Description
MS	Module status	Green / Red	See MS status LED below
BATTERY	Battery status	Red	On when RTC battery needs to be replaced
APP0	Application LEDs	Green / Red	Managed by user application
APP1			

For further details on the following LEDs:

- Eth LA, Eth ST and Eth NS, please refer to Ethernet Port - Status LEDs (*see page 93*).
- USB Host, please refer to USB Host Port - Status LED (*see page 102*).
- MBS COM, please refer to Serial Line Port - Status LED (*see page 105*).
- CAN0 STS, please refer to CAN Port - Status LED (*see page 98*).

The following table describes the MS status LED:

Status LED	Controller State	Prg Port Communication	Application Execution
Flashing green / red	BOOTING	No	No
Flashing red	INVALID OS	Restricted	No
Single flash green	EMPTY	Yes	No
Green ON	RUNNING	Yes	Yes
3 flash green	RUNNING with Breakpoint	Yes	Restricted
Flashing green	STOPPED	Restricted	No
Single flash red	HALT	Yes	No
Rapid flashing red	REBOOT after a hardware error has been detected	Yes	No (Empty)
Red ON	HALT after system error detected	No	No

Status LED	Controller State	Prg Port Communication	Application Execution
OFF	No power	No	No
Green / with single flash red	RUNNING with external error detected Or different Boot Project Or no Boot Project	Yes	Yes
Flashing green / with single flash red	STOPPED with external error detected	Restricted	No

NOTE: For further details on controller states, refer to the Operating Mode discussion in the Programming Guide for your particular controller.

Controller States

The following table describes the controller states:

State	Description
BOOTING	The controller executes the boot firmware and its own internal self tests. It does not execute the application nor does it communicate. It then checks the checksum of the firmware and user application.
INVALID_OS	The Operating System is not valid. The controller can not execute an application. Communications are restricted.
EMPTY	The user application is not valid or a hardware error has been detected. The controller does not execute the application but it can communicate.
RUNNING	The controller executes the application.
STOPPED	The controller has a valid application that is stopped.
HALT	The controller has detected an application or system error and has ceased application execution.

NOTE: For further details on controller states, refer to the Operating Mode discussion in the Programming Guide for your particular controller.

Dimensions

The following figure shows the external dimensions of the controller:

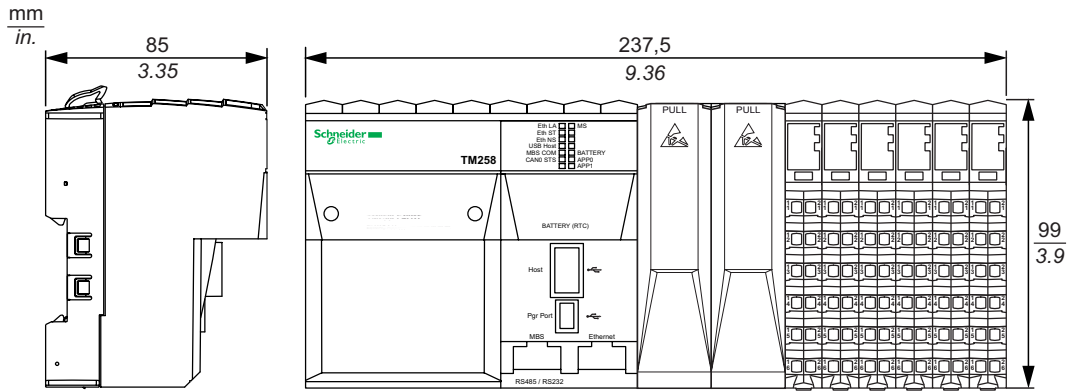

The following table describes the weight of the TM258LD42DT4L:

Weight	
TM258LD42DT4L	770 g (24.7 oz)

Characteristics of the Controller Power Distribution Module

The Controller Power Distribution Module (CPDM) has three 24 Vdc power connections:

- Main power (**Ctrl**)
- Expert I/O power (**Exp.**)
- 24 Vdc I/O Power Segment power (**I/O**)

The state of these three power connections is indicated by a set of LEDs on the CPDM:

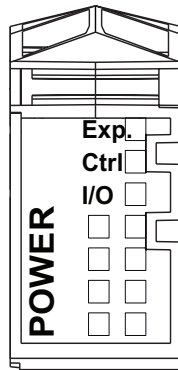

The following table describes the CPDM LED display:

LEDs	Color	Status	Description
Exp. (Expert I/O power)	Green	On	24 Vdc applied
Ctrl (Main power)	Green	On	24 Vdc applied
I/O (24 Vdc I/O Power Segment power)	Green	On	24 Vdc applied

The Main power serves the TM5 power bus, the Serial Line port, the USB port, any PCI modules that may be installed, and power for the controller electronics.

The Expert I/O power serves the Expert I/O module inputs and outputs, the power for the embedded Encoder port, and power for the Expert I/O module electronics.

The 24 Vdc I/O power segment power serves the Regular I/O modules inputs and outputs, as well as providing power to the first segment of the 24 Vdc I/O Power segment for any optional I/O slices of the local configuration.

CPDM Power Consumption Overview

The following table shows the power characteristics of the TM258LD42DT4L:

Rated voltage CPDM		24 Vdc	
Voltage range CPDM		20.4...28.8 Vdc	
Main power	Minimum current (no external loads)	0.3 A	
	Maximum current including the following loads:	1.2 A	
		Current for TM5 bus power when adding expansion modules	0...0.1 A
		Current for serial line when connected devices consume power	0...0.05 A
		Current for USB Host when connected devices consume power	0...0.1 A
		Current for optional PCI modules when connected devices consume power	Refer to your specific PCI module (see <i>Modicon TM5, PCI Modules, Hardware Guide</i>)
	Inrush current	Time < 70 μ s	100 A max.
70...2000 μ s		3 A max.	
Internal protection	No	see note 1	
Embedded Expert modules power	Minimum current (no external loads)	0.04 A	
	Maximum current including the following loads:	0.9 A	
		Current for Expert Inputs	0...0.1 A
		Current for Expert Outputs	0...0.8 A
	Inrush current	Time < 150 μ s	50 A max.
Internal protection	No	see note 1	
24 Vdc I/O power segment	Maximum current (depending on the modules on the segment)	10 A max.	
	Inrush current (depending on the modules on the segment)	Time < 500 μ s 25 A max.	
	Internal protection	No	see note 1

¹ Add external fuse as specified in the wiring diagrams.

Refer to the chapter *Example 1: Current Consumed by a Local Configuration* (see *Modicon TM5 / TM7 Flexible System, System Planning and Installation Guide*) for further details on power consumption.

TM258LF42DT**



6

Introduction

This chapter describes the TM258LF42DT** controller.

What's in this Chapter?

This chapter contains the following topics:

Topic	Page
General Description	58
Characteristics of the Controller Power Distribution Module	62

General Description

Overview

The following figure shows the different components of the TM258LF42DT••:

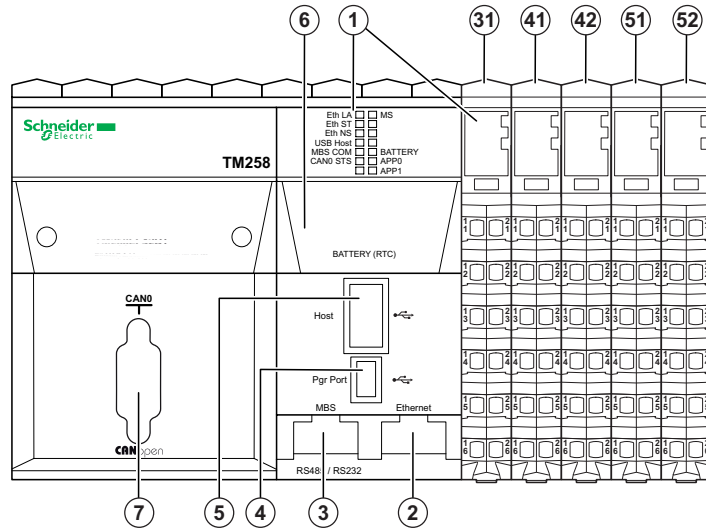

N°	Designation / Description	Refer to
1	LED status	Status LEDs (<i>see page 59</i>)
2	Ethernet port / Type RJ45	Ethernet Port (<i>see page 92</i>)
3	Serial line / Type RJ45 (RS232 or RS485)	Serial Line Port (<i>see page 103</i>)
4	USB programming port /For terminal connection to a programming PC (SoMachine)	USB Programming Port (<i>see page 99</i>)
5	USB host / For memory key management	USB Host Port (<i>see page 101</i>)
6	Battery	RTC Battery (<i>see page 34</i>)
7	CAN 0 port / Male D-Sub 9 CANopen Master	CAN Port (<i>see page 95</i>)
31	Controller Power Distribution Module / For connecting external power supplies	Controller Power Distribution Module (<i>see page 32</i>)
41	Embedded Expert I/O modules / 5 fast inputs, 2 regular inputs, 2 fast outputs	Embedded Expert I/O (<i>see page 109</i>)
42		
51	Embedded Regular Input module / 12 digital inputs	Digital DI12DE (<i>see page 127</i>)
52	Embedded Regular Output module / 12 digital outputs	Digital DO12TE (<i>see page 131</i>)

Status LEDs

The following figure shows the LEDs on the front panel display:

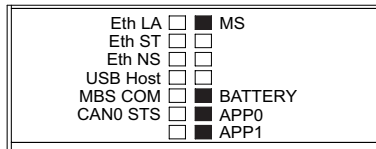

The following table describes the controller status LEDs:

Marking	Description	LED	
		Color	Description
MS	Module status	Green / Red	See MS status LED below
BATTERY	Battery status	Red	On when RTC battery needs to be replaced
APP0	Application LEDs	Green / Red	Managed by user application
APP1			

For further details on the following LEDs:

- Eth LA, Eth ST and Eth NS, please refer to Ethernet Port - Status LEDs (*see page 93*).
- USB Host, please refer to USB Host Port - Status LED (*see page 102*).
- MBS COM, please refer to Serial Line Port - Status LED (*see page 105*).
- CAN0 STS, please refer to CAN Port - Status LED (*see page 98*).

The following table describes the MS status LED:

Status LED	Controller State	Prg Port Communication	Application Execution
Flashing green / red	BOOTING	No	No
Flashing red	INVALID OS	Restricted	No
Single flash green	EMPTY	Yes	No
Green ON	RUNNING	Yes	Yes
3 flash green	RUNNING with Breakpoint	Yes	Restricted
Flashing green	STOPPED	Restricted	No
Single flash red	HALT	Yes	No
Rapid flashing red	REBOOT after a hardware error has been detected	Yes	No (Empty)
Red ON	HALT after system error detected	No	No

Status LED	Controller State	Prg Port Communication	Application Execution
OFF	No power	No	No
Green / with single flash red	RUNNING with external error detected Or different Boot Project Or no Boot Project	Yes	Yes
Flashing green / with single flash red	STOPPED with external error detected	Restricted	No

NOTE: For further details on controller states, refer to the Operating Mode discussion in the Programming Guide for your particular controller.

Controller States

The following table describes the controller states:

State	Description
BOOTING	The controller executes the boot firmware and its own internal self tests. It does not execute the application nor does it communicate. It then checks the checksum of the firmware and user application.
INVALID_OS	The Operating System is not valid. The controller can not execute an application. Communications are restricted.
EMPTY	The user application is not valid or a hardware error has been detected. The controller does not execute the application but it can communicate.
RUNNING	The controller executes the application.
STOPPED	The controller has a valid application that is stopped.
HALT	The controller has detected an application or system error and has ceased application execution.

NOTE: For further details on controller states, refer to the Operating Mode discussion in the Programming Guide for your particular controller.

Dimensions

The following figure shows the external dimensions of the controller:

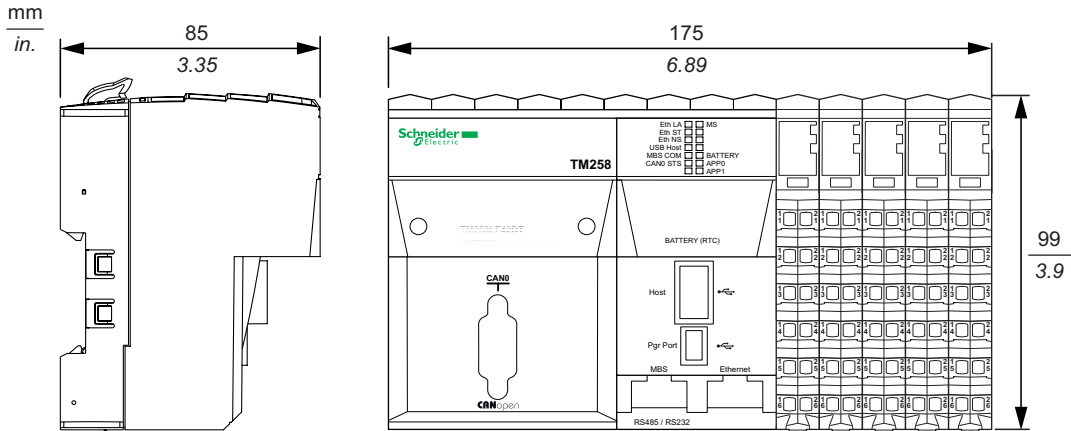

The following table describes the weight of the TM258LF42DT••:

Weight	
TM258LF42DT••	550 g (19.4 oz)

Characteristics of the Controller Power Distribution Module

The Controller Power Distribution Module (CPDM) has three 24 Vdc power connections:

- Main power (**Ctrl**)
- Expert I/O power (**Exp.**)
- 24 Vdc I/O Power Segment power (**I/O**)

The state of these three power connections is indicated by a set of LEDs on the CPDM:

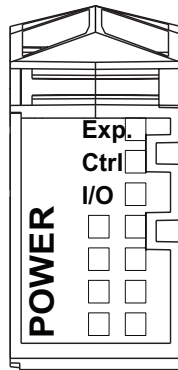

The following table describes the CPDM LED display:

LEDs	Color	Status	Description
Exp. (Expert I/O power)	Green	On	24 Vdc applied
Ctrl (Main power)	Green	On	24 Vdc applied
I/O (24 Vdc I/O Power Segment power)	Green	On	24 Vdc applied

The Main power serves the TM5 power bus, the Serial Line port, the USB port, any PCI modules that may be installed, and power for the controller electronics.

The Expert I/O power serves the Expert I/O module inputs and outputs, the power for the embedded Encoder port, and power for the Expert I/O module electronics.

The 24 Vdc I/O power segment power serves the Regular I/O modules inputs and outputs, as well as providing power to the first segment of the 24 Vdc I/O Power segment for any optional I/O slices of the local configuration.

CPDM Power Consumption Overview

The following table shows the power characteristics of the TM258LF42DT••:

Rated voltage CPDM		24 Vdc	
Voltage range CPDM		20.4...28.8 Vdc	
Main power	Minimum current (no external loads)	0.3 A	
	Maximum current including the following loads:	0.8 A	
		Current for TM5 bus power when adding expansion modules	0...0.1 A
		Current for serial line when connected devices consume power	0...0.05 A
		Current for USB Host when connected devices consume power	0...0.1 A
	Inrush current	Time < 70 μ s	100 A max.
		70...2000 μ s	3 A max.
Internal protection	No	see note 1	
Embedded Expert modules power	Minimum current (no external loads)	0.04 A	
	Maximum current including the following loads:	0.9 A	
		Current for Expert Inputs	0...0.1 A
		Current for Expert Outputs	0...0.8 A
	Inrush current	Time < 150 μ s	50 A max.
	Internal protection	No	see note 1
24 Vdc I/O power segment	Maximum current (depending on the modules on the segment)	10 A max.	
	Inrush current (depending on the modules on the segment)	Time < 500 μ s	25 A max.
	Internal protection	No	see note 1

¹ Add external fuse as specified in the wiring diagrams.

Refer to the chapter *Example 1: Current Consumed by a Local Configuration* (see *Modicon TM5 / TM7 Flexible System, System Planning and Installation Guide*) for further details on power consumption.

TM258LF42DT4L••



7

Introduction

This chapter describes the TM258LF42DT4L•• controller.

What's in this Chapter?

This chapter contains the following topics:

Topic	Page
General Description	66
Characteristics of the Controller Power Distribution Module	70

General Description

Overview

The following figure shows the different components of the TM258LF42DT4L••:

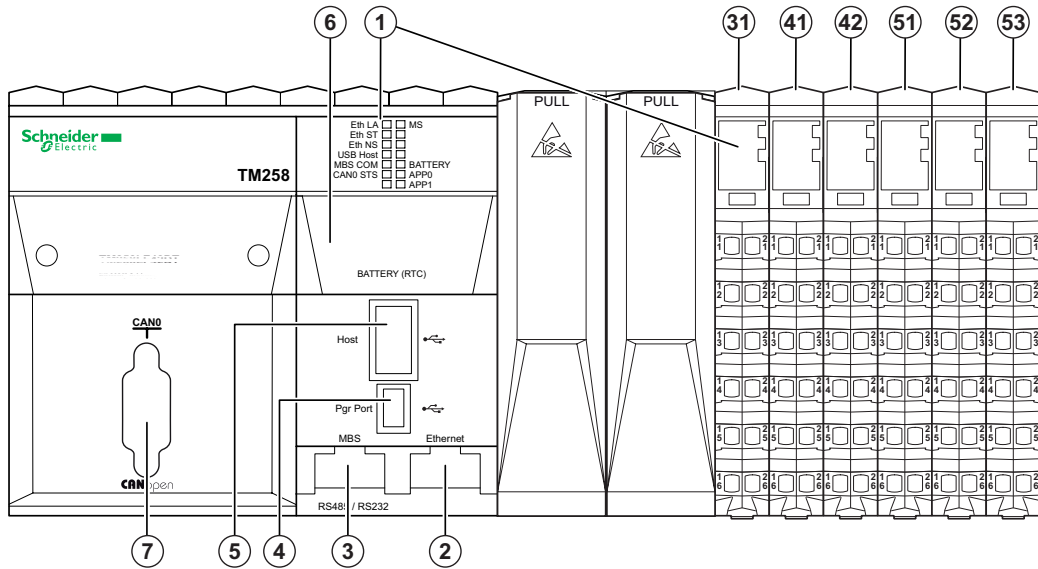

N°	Designation / Description	Refer to
1	LED status	Status LEDs (<i>see page 67</i>)
2	Ethernet port / Type RJ45	Ethernet Port (<i>see page 92</i>)
3	Serial line / Type RJ45 (RS232 or RS485)	Serial Line Port (<i>see page 103</i>)
4	USB programming port /For terminal connection to a programming PC (SoMachine)	USB Programming Port (<i>see page 99</i>)
5	USB host / For memory key management	USB Host Port (<i>see page 101</i>)
6	Battery	RTC Battery (<i>see page 34</i>)
7	CAN 0 Port / Male Sub-D 9 CANopen Master	CAN Port (<i>see page 95</i>)
31	Controller Power Distribution Module / For connecting external power supplies	Controller Power Distribution Module (<i>see page 32</i>)
41	Embedded Expert I/O modules / 5 fast inputs, 2 regular inputs, 2 fast outputs	Embedded Expert I/O (<i>see page 109</i>)
42		
51	Embedded Regular Input module / 12 digital inputs	Digital DI12DE (<i>see page 127</i>)
52	Embedded Regular Output module / 12 digital outputs	Digital DO12TE (<i>see page 131</i>)
53	Embedded Regular Input module / 4 analog inputs (12-bits)	Analog AI4LE (<i>see page 136</i>)

Status LEDs

The following figure shows the LEDs on the front panel display:

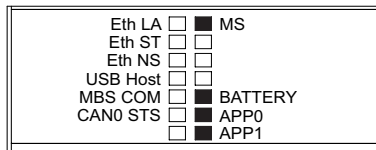

The following table describes the controller status LEDs:

Marking	Description	LED	
		Color	Description
MS	Module status	Green / Red	See MS status LED below
BATTERY	Battery status	Red	On when RTC battery needs to be replaced
APP0	Application LEDs	Green / Red	Managed by user application
APP1			

For further details on the following LEDs:

- Eth LA, Eth ST and Eth NS, please refer to Ethernet Port - Status LEDs (*see page 93*).
- USB Host, please refer to USB Host Port - Status LED (*see page 102*).
- MBS COM, please refer to Serial Line Port - Status LED (*see page 105*).
- CAN0 STS, please refer to CAN Port - Status LED (*see page 98*).

The following table describes the MS status LED:

Status LED	Controller State	Prg Port Communication	Application Execution
Flashing green / red	BOOTING	No	No
Flashing red	INVALID OS	Restricted	No
Single flash green	EMPTY	Yes	No
Green ON	RUNNING	Yes	Yes
3 flash green	RUNNING with Breakpoint	Yes	Restricted
Flashing green	STOPPED	Restricted	No
Single flash red	HALT	Yes	No
Rapid flashing red	REBOOT after a hardware error has been detected	Yes	No (Empty)
Red ON	HALT after system error detected	No	No

Status LED	Controller State	Prg Port Communication	Application Execution
OFF	No power	No	No
Green / with single flash red	RUNNING with external error detected Or different Boot Project Or no Boot Project	Yes	Yes
Flashing green / with single flash red	STOPPED with external error detected	Restricted	No

NOTE: For further details on controller states, refer to the Operating Mode discussion in the Programming Guide for your particular controller.

Controller States

The following table describes the controller states:

State	Description
BOOTING	The controller executes the boot firmware and its own internal self tests. It does not execute the application nor does it communicate. It then checks the checksum of the firmware and user application.
INVALID_OS	The Operating System is not valid. The controller can not execute an application. Communications are restricted.
EMPTY	The user application is not valid or a hardware error has been detected. The controller does not execute the application but it can communicate.
RUNNING	The controller executes the application.
STOPPED	The controller has a valid application that is stopped.
HALT	The controller has detected an application or system error and has ceased application execution.

NOTE: For further details on controller states, refer to the Operating Mode discussion in the Programming Guide for your particular controller.

Dimensions

The following figure shows the external dimensions of the controller:

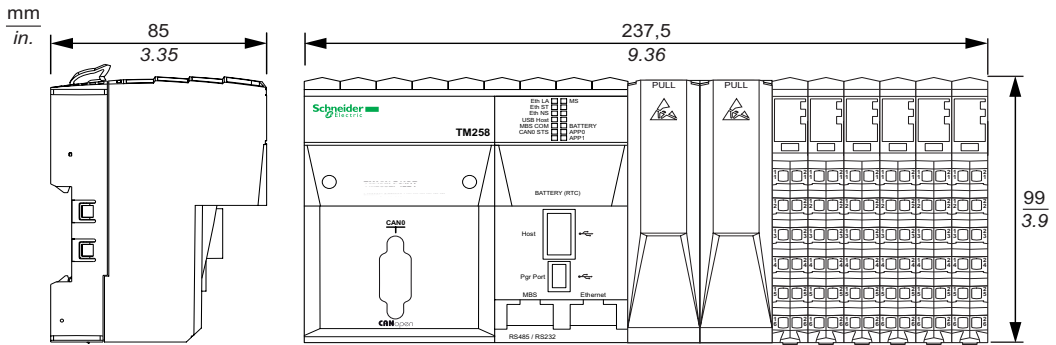

The following table describes the weight of the TM258LF42DT4L**:

Weight	
TM258LF42DT4L**	770 g (24.7 oz)

Characteristics of the Controller Power Distribution Module

The Controller Power Distribution Module (CPDM) has three 24 Vdc power connections:

- Main power (**Ctrl**)
- Expert I/O power (**Exp.**)
- 24 Vdc I/O Power Segment power (**I/O**)

The state of these three power connections is indicated by a set of LEDs on the CPDM:

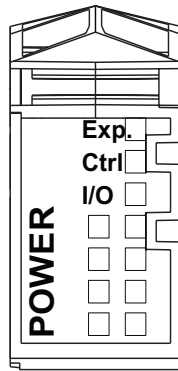

The following table describes the CPDM LED display:

LEDs	Color	Status	Description
Exp. (Expert I/O power)	Green	On	24 Vdc applied
Ctrl (Main power)	Green	On	24 Vdc applied
I/O (24 Vdc I/O Power Segment power)	Green	On	24 Vdc applied

The Main power serves the TM5 power bus, the Serial Line port, the USB port, any PCI modules that may be installed, and power for the controller electronics.

The Expert I/O power serves the Expert I/O module inputs and outputs, the power for the embedded Encoder port, and power for the Expert I/O module electronics.

The 24 Vdc I/O power segment power serves the Regular I/O modules inputs and outputs, as well as providing power to the first segment of the 24 Vdc I/O Power segment for any optional I/O slices of the local configuration.

CPDM Power Consumption Overview

The following table shows the power characteristics of the TM258LF42DT4L**:

Rated voltage CPDM		24 Vdc	
Voltage range CPDM		20.4...28.8 Vdc	
Main power	Minimum current (no external loads)	0.3 A	
	Maximum current including the following loads:	1.2 A	
		Current for TM5 bus power when adding expansion modules	0...0.1 A
		Current for serial line when connected devices consume power	0...0.05 A
		Current for USB Host when connected devices consume power	0...0.1 A
		Current for optional PCI modules when connected devices consume power	Refer to your specific PCI module (see <i>Modicon TM5, PCI Modules, Hardware Guide</i>)
	Inrush current	Time < 70 μ s	100 A max.
70...2000 μ s		3 A max.	
Internal protection	No	see note 1	
Embedded Expert modules power	Minimum current (no external loads)	0.04 A	
	Maximum current including the following loads:	0.9 A	
		Current for Expert Inputs	0...0.1 A
		Current for Expert Outputs	0...0.8 A
	Inrush current	Time < 150 μ s	50 A max.
Internal protection	No	see note 1	
24 Vdc I/O power segment	Maximum current (depending on the modules on the segment)	10 A max.	
	Inrush current (depending on the modules on the segment)	Time < 500 μ s 25 A max.	
	Internal protection	No	see note 1

¹ Add external fuse as specified in the wiring diagrams.

Refer to the chapter *Example 1: Current Consumed by a Local Configuration* (see *Modicon TM5 / TM7 Flexible System, System Planning and Installation Guide*) for further details on power consumption.

TM258LF66DT4L••



8

Introduction

This chapter describes the TM258LF66DT4L•• controller.

What's in this Chapter?

This chapter contains the following topics:

Topic	Page
General Description	74
Characteristics of the Controller Power Distribution Module	78

General Description

Overview

The following figure shows the different components of the TM258LF66DT4L••:

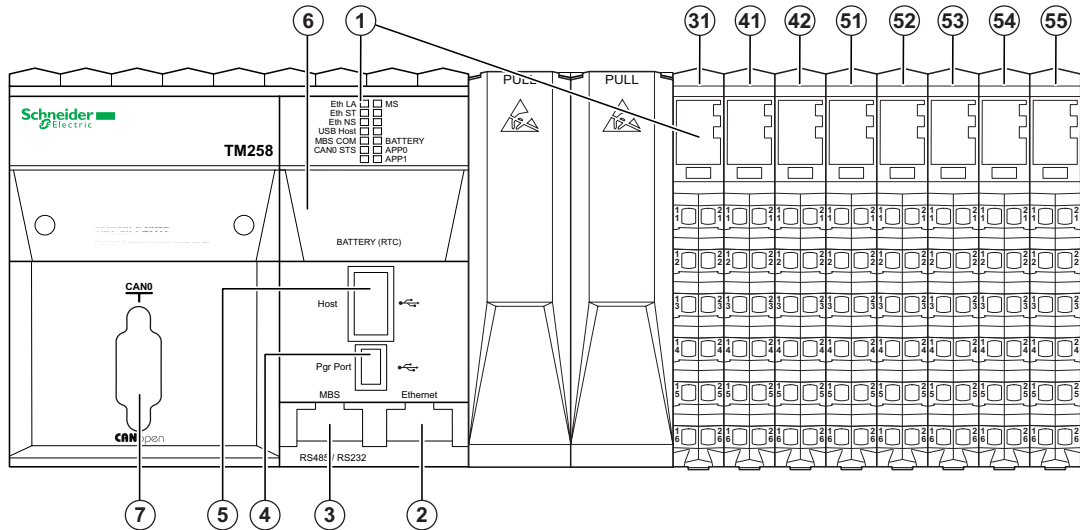

N°	Designation / Description	Refer to
1	LED status	Status LEDs (<i>see page 75</i>)
2	Ethernet port / Type RJ45	Ethernet Port (<i>see page 92</i>)
3	Serial line / Type RJ45 (RS232 or RS485)	Serial Line Port (<i>see page 103</i>)
4	USB programming port / For terminal connection to a programming PC (SoMachine)	USB Programming Port (<i>see page 99</i>)
5	USB host / For memory key management	USB Host Port (<i>see page 101</i>)
6	Battery	RTC Battery (<i>see page 34</i>)
7	CAN 0 Port / Male Sub-D 9 CANOpen Master	CAN Port (<i>see page 95</i>)
31	Controller Power distribution Module / For connecting external power supplies	Controller Power Distribution Module (<i>see page 32</i>)
41	Embedded Expert I/O modules / 5 fast inputs, 2 regular inputs, 2 fast outputs	Embedded Expert I/O (<i>see page 109</i>)
42		
51	Embedded Regular Input modules / 12 digital inputs	Digital DI12DE (<i>see page 127</i>)
52		

N°	Designation / Description	Refer to
53	Embedded Regular Output modules / 12 digital outputs	Digital DO12TE (see page 131)
54		
55	Embedded Regular Input module / 4 analog inputs (12-bits)	Analog AI4LE (see page 136)

Status LEDs

The following figure shows the LEDs on the front panel display:

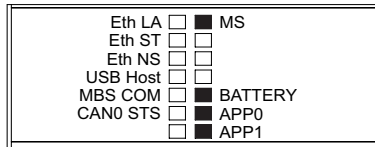

The following table describes the controller status LEDs:

Marking	Description	LED	
		Color	Description
MS	Module status	Green / Red	See MS status LED below
BATTERY	Battery status	Red	On when RTC battery needs to be replaced
APP0	Application LEDs	Green / Red	Managed by user application
APP1			

For further details on the following LEDs:

- Eth LA, Eth ST and Eth NS, please refer to Ethernet Port - Status LEDs (see page 93).
- USB Host, please refer to USB Host Port - Status LED (see page 102).
- MBS COM, please refer to Serial Line Port - Status LED (see page 105).
- CAN0 STS, please refer to CAN Port - Status LED (see page 98).

The following table describes the MS status LED:

Status LED	Controller State	Prg Port Communication	Application Execution
Flashing green / red	BOOTING	No	No
Flashing red	INVALID OS	Restricted	No
Single flash green	EMPTY	Yes	No
Green ON	RUNNING	Yes	Yes
3 flash green	RUNNING with Breakpoint	Yes	Restricted
Flashing green	STOPPED	Restricted	No

Status LED	Controller State	Prg Port Communication	Application Execution
Single flash red	HALT	Yes	No
Rapid flashing red	REBOOT after a hardware error has been detected	Yes	No (Empty)
Red ON	HALT after system error detected	No	No
OFF	No power	No	No
Green / with single flash red	RUNNING with external error detected Or different Boot Project Or no Boot Project	Yes	Yes
Flashing green / with single flash red	STOPPED with external error detected	Restricted	No

NOTE: For further details on controller states, refer to the Operating Mode discussion in the Programming Guide for your particular controller.

Controller States

The following table describes the controller states:

State	Description
BOOTING	The controller executes the boot firmware and its own internal self tests. It does not execute the application nor does it communicate. It then checks the checksum of the firmware and user application.
INVALID_OS	The Operating System is not valid. The controller can not execute an application. Communications are restricted.
EMPTY	The user application is not valid or a hardware error has been detected. The controller does not execute the application but it can communicate.
RUNNING	The controller executes the application.
STOPPED	The controller has a valid application that is stopped.
HALT	The controller has detected an application or system error and has ceased application execution.

NOTE: For further details on controller states, refer to the Operating Mode discussion in the Programming Guide for your particular controller.

Dimensions

The following figure shows the external dimensions of the controller:

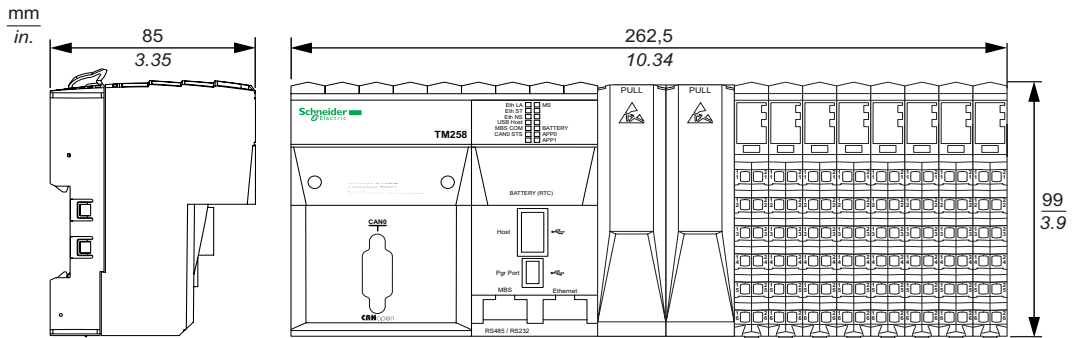

The following table describes the weight of the TM258LF66DT4L**:

Weight	
TM258LF66DT4L**	800 g (28.2 oz)

Characteristics of the Controller Power Distribution Module

The Controller Power Distribution Module (CPDM) has three 24 Vdc power connections:

- Main power (**Ctrl**)
- Expert I/O power (**Exp.**)
- 24 Vdc I/O Power Segment power (**I/O**)

The state of these three power connections is indicated by a set of LEDs on the CPDM:

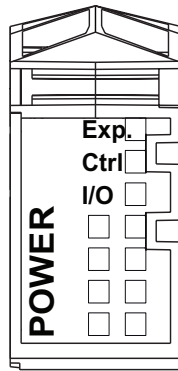

The following table describes the CPDM LED display:

LEDs	Color	Status	Description
Exp. (Expert I/O power)	Green	On	24 Vdc applied
Ctrl (Main power)	Green	On	24 Vdc applied
I/O (24 Vdc I/O Power Segment power)	Green	On	24 Vdc applied

The Main power serves the TM5 power bus, the Serial Line port, the USB port, any PCI modules that may be installed, and power for the controller electronics.

The Expert I/O power serves the Expert I/O module inputs and outputs, the power for the embedded Encoder port, and power for the Expert I/O module electronics.

The 24 Vdc I/O power segment power serves the Regular I/O modules inputs and outputs, as well as providing power to the first segment of the 24 Vdc I/O Power segment for any optional I/O slices of the local configuration.

CPDM Power Consumption Overview

The following table shows the power characteristics of the TM258LF66DT4L**:

Rated voltage CPDM		24 Vdc	
Voltage range CPDM		20.4...28.8 Vdc	
Main power	Minimum current (no external loads)	0.3 A	
	Maximum current including the following loads:	1.2 A	
		Current for TM5 bus power when adding expansion modules	0...0.1 A
		Current for serial line when connected devices consume power	0...0.05 A
		Current for USB Host when connected devices consume power	0...0.1 A
		Current for optional PCI modules when connected devices consume power	Refer to your specific PCI module (see <i>Modicon TM5, PCI Modules, Hardware Guide</i>)
	Inrush current	Time < 70 μ s	100 A max.
70...2000 μ s		3 A max.	
Internal protection	No	see note 1	
Embedded Expert modules power	Minimum current (no external loads)	0.04 A	
	Maximum current including the following loads:	0.9 A	
		Current for Expert Inputs	0...0.1 A
		Current for Expert Outputs	0...0.8 A
	Inrush current	Time < 150 μ s	50 A max.
Internal protection	No	see note 1	
24 Vdc I/O power segment	Maximum current (depending on the modules on the segment)	10 A max.	
	Inrush current (depending on the modules on the segment)	Time < 500 μ s 25 A max.	
	Internal protection	No	see note 1

¹ Add external fuse as specified in the wiring diagrams.

Refer to the chapter *Example 1: Current Consumed by a Local Configuration* (see *Modicon TM5 / TM7 Flexible System, System Planning and Installation Guide*) for further details on power consumption.

TM258LF42DR••

9

Introduction

This chapter describes the TM258LF42DR•• controller.

What's in this Chapter?

This chapter contains the following topics:

Topic	Page
General Description	82
Characteristics of the Controller Power Distribution Module	86

General Description

Overview

The following figure shows the different components of the TM258LF42DR••:

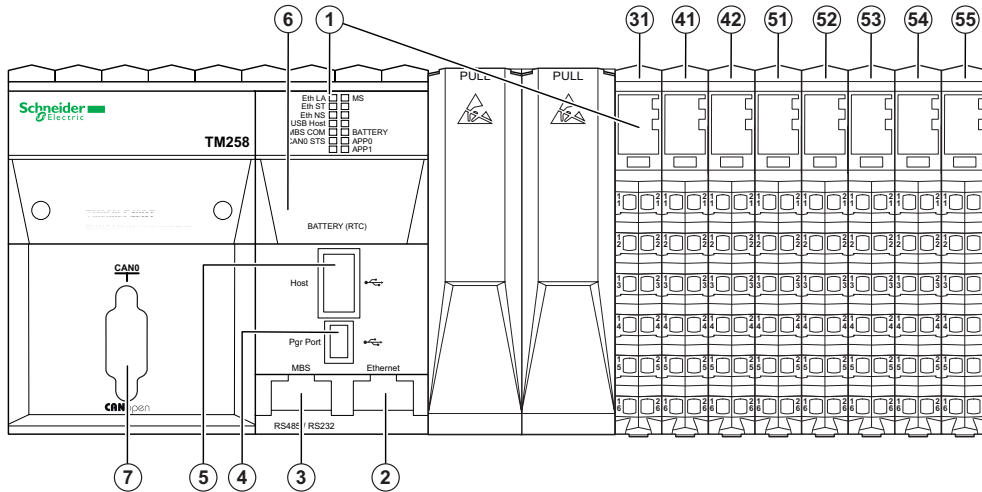

N°	Designation / Description	Refer to
1	LED status	Status LEDs (<i>see page 83</i>)
2	Ethernet port / Type RJ45	Ethernet Port (<i>see page 92</i>)
3	RS485 port / Type RJ45 (RS232 or RS485)	Serial Line Port (<i>see page 103</i>)
4	USB programming port / For terminal connection to a programming PC (SoMachine)	USB Programming Port (<i>see page 99</i>)
5	USB host / For memory key management	USB Host Port (<i>see page 101</i>)
6	Battery	RTC Battery (<i>see page 34</i>)
7	CAN 0 Port / Male Sub-D 9 CANopen Master	CAN Port (<i>see page 95</i>)
31	Controller Power Distribution Module / For connecting external power supplies	Controller Power Distribution Module (<i>see page 32</i>)
41	Embedded Expert I/O modules / 5 fast inputs, 2 regular inputs, 2 fast outputs	Embedded Expert I/O (<i>see page 109</i>)
42		
51	Embedded Regular Input modules / 6 digital inputs	Digital DI12DE (<i>see page 127</i>)
52		
53	Embedded Regular Output modules / 6 relay outputs	Relay DO6RE (<i>see page 141</i>)
54		

Status LEDs

The following figure shows the LEDs on the front panel display:

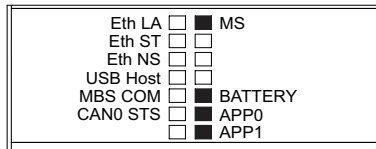

The following table describes the controller status LEDs:

Marking	Description	LED	
		Color	Description
MS	Module status	Green / Red	See MS status LED below
BATTERY	Battery status	Red	On when RTC battery needs to be replaced
APP0	Application LEDs	Green / Red	Managed by user application
APP1			

For further details on the following LEDs:

- Eth LA, Eth ST and Eth NS, please refer to Ethernet Port - Status LEDs (*see page 93*).
- USB Host, please refer to USB Host Port - Status LED (*see page 102*).
- MBS COM, please refer to Serial Line Port - Status LED (*see page 105*).
- CAN0 STS, please refer to CAN Port - Status LED (*see page 98*).

The following table describes the MS status LED:

Status LED	Controller State	Prg Port Communication	Application Execution
Flashing green / red	BOOTING	No	No
Flashing red	INVALID OS	Restricted	No
Single flash green	EMPTY	Yes	No
Green ON	RUNNING	Yes	Yes
3 flash green	RUNNING with Breakpoint	Yes	Restricted
Flashing green	STOPPED	Restricted	No
Single flash red	HALT	Yes	No
Rapid flashing red	REBOOT after a hardware error has been detected	Yes	No (Empty)
Red ON	HALT after system error detected	No	No

Status LED	Controller State	Prg Port Communication	Application Execution
OFF	No power	No	No
Green / with single flash red	RUNNING with external error detected Or different Boot Project Or no Boot Project	Yes	Yes
Flashing green / with single flash red	STOPPED with external error detected	Restricted	No

NOTE: For further details on controller states, refer to the Operating Mode discussion in the Programming Guide for your particular controller.

Controller States

The following table describes the controller states:

State	Description
BOOTING	The controller executes the boot firmware and its own internal self tests. It does not execute the application nor does it communicate. It then checks the checksum of the firmware and user application.
INVALID_OS	The Operating System is not valid. The controller can not execute an application. Communications are restricted.
EMPTY	The user application is not valid or a hardware error has been detected. The controller does not execute the application but it can communicate.
RUNNING	The controller executes the application.
STOPPED	The controller has a valid application that is stopped.
HALT	The controller has detected an application or system error and has ceased application execution.

NOTE: For further details on controller states, refer to the Operating Mode discussion in the Programming Guide for your particular controller.

Dimensions

The following figure shows the external dimensions of the controller:

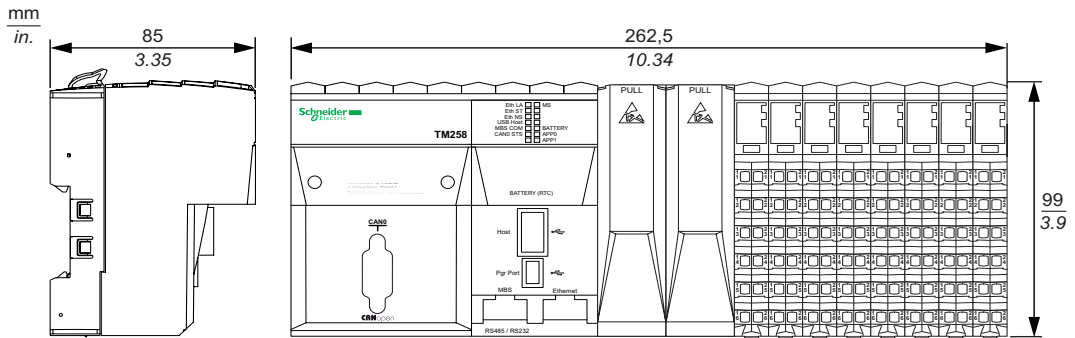

The following table describes the weight of the TM258LF42DR••:

Weight	
TM258LF42DR••	800 g (28.2 oz)

Characteristics of the Controller Power Distribution Module

The Controller Power Distribution Module (CPDM) has three 24 Vdc power connections:

- Main power (**Cutler**)
- Expert I/O power (**Expo.**)
- 24 Vdc I/O Power Segment power (**I/O**)

The state of these three power connections is indicated by a set of LEDs on the CPDM:

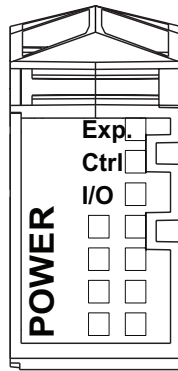

The following table describes the CPDM LED display:

LEDs	Color	Status	Description
Expo. (Expert I/O power)	Green	On	24 Vdc applied
Ctrl (Main power)	Green	On	24 Vdc applied
I/O (24 Vdc I/O Power Segment power)	Green	On	24 Vdc applied

The Main power serves the TM5 power bus, the Serial Line port, the USB port, any PCI modules that may be installed, and power for the controller electronics.

The Expert I/O power serves the Expert I/O module inputs and outputs, the power for the embedded Encoder port, and power for the Expert I/O module electronics.

The 24 Vdc I/O power segment power serves the Regular I/O modules inputs and outputs, as well as providing power to the first segment of the 24 Vdc I/O Power segment for any optional I/O slices of the local configuration.

CPDM Power Consumption Overview

The following table shows the power characteristics of the TM258LF42DR**:

Rated voltage CPDM		24 Vdc	
Voltage range CPDM		20.4...28.8 Vdc	
Main power	Minimum current (no external loads)	0.3 A	
	Maximum current including the following loads:	1.3 A	
		Current for TM5 bus power when adding expansion modules	0...0.1 A
		Current for serial line when connected devices consume power	0...0.05 A
		Current for USB Host when connected devices consume power	0...0.1 A
		Current for optional PCI modules when connected devices consume power	Refer to your specific PCI module (see <i>Modicon TM5, PCI Modules, Hardware Guide</i>)
	Inrush current	Time < 70 μ s	100 A max.
70...2000 μ s		3 A max.	
Internal protection	No	see note 1	
Embedded Expert modules power	Minimum current (no external loads)	0.04 A	
	Maximum current including the following loads:	0.9 A	
		Current for Expert Inputs	0...0.1 A
		Current for Expert Outputs	0...0.8 A
	Inrush current	Time < 150 μ s	50 A max.
Internal protection	No	see note 1	
24 Vdc I/O power segment	Maximum current (depending on the modules on the segment)	10 A max.	
	Inrush current (depending on the modules on the segment)	Time < 500 μ s	25 A max.
	Internal protection	No	see note 1

¹ Add external fuse as specified in the wiring diagrams.

Refer to the chapter *Example 1: Current Consumed by a Local Configuration* (see *Modicon TM5 / TM7 Flexible System, System Planning and Installation Guide*) for further details on power consumption.

Power Distribution Wiring Diagram

10

Wiring Diagram for External Power Supplies

Wiring Diagram

 WARNING
POTENTIAL OF OVERHEATING AND FIRE <ul style="list-style-type: none">• Do not connect the modules directly to line voltage.• Use only isolating PELV or SELV power supplies to supply power to the modules. <p>Failure to follow these instructions can result in death, serious injury, or equipment damage.</p>

The following figure shows the wiring diagram of the Controller Power Distribution Module (CPDM):

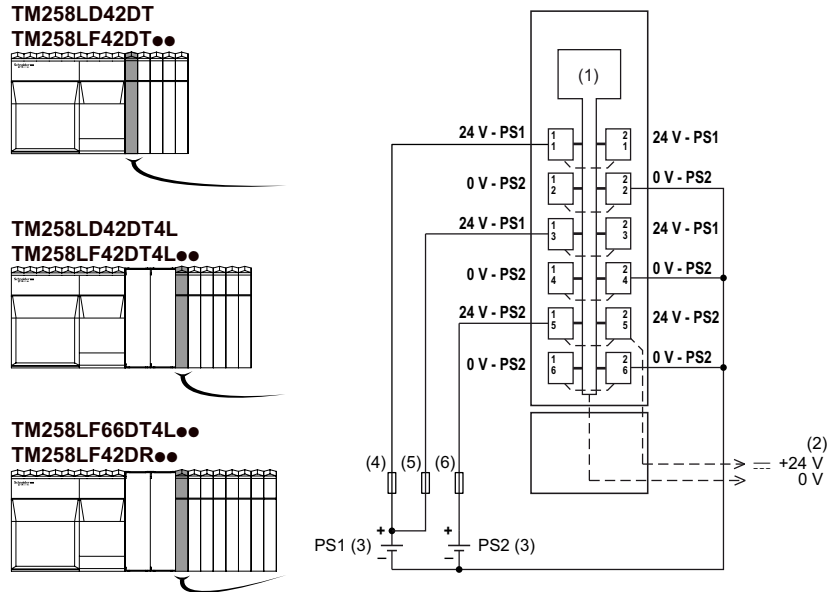

- 1 Internal electronics
- 2 24 Vdc I/O power segment integrated into the bus bases
- 3 PS1/PS2: External isolated power supply 24 Vdc
- 4 External fuse, Type T slow-blow, 3 A 250 V
- 5 External fuse, Type T slow-blow, 2 A 250 V
- 6 External fuse, Type T slow-blow, 10 A max., 250 V

⚠ DANGER

FIRE HAZARD

Use only the recommended wire sizes for I/O channels and power supplies.
Failure to follow these instructions will result in death or serious injury.

⚠ WARNING

UNINTENDED EQUIPMENT OPERATION

Do not exceed any of the rated values specified in the following tables.
Failure to follow these instructions can result in death, serious injury, or equipment damage.

Integrated Communication Ports

11

What's in this Chapter?

This chapter contains the following topics:

Topic	Page
Ethernet Port	92
CAN Port	95
USB Programming Port	99
USB Host Port	101
Serial Line Port	103

Ethernet Port

Overview

The following figure shows the location of the Ethernet port of the controller:

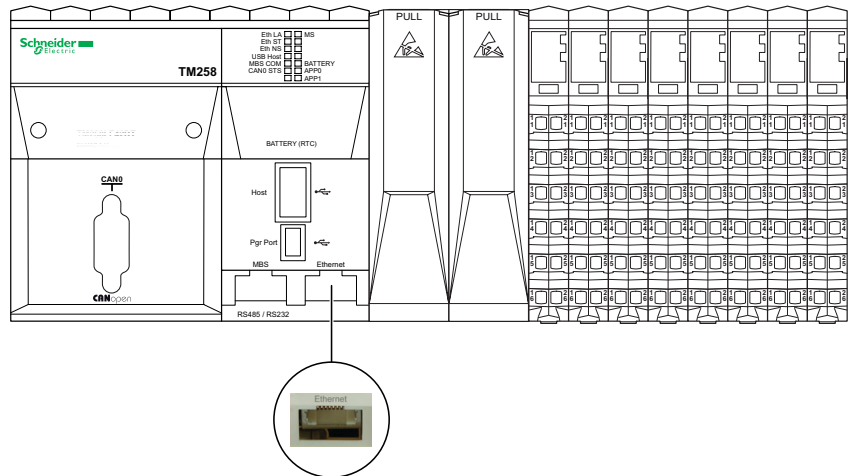

For more information, please refer to Transparent Ready User Guide.

Characteristics

The following table describes the different Ethernet characteristics:

Characteristic	Description
Standard	Ethernet
Connector type	RJ45
Baud rate	Supports Ethernet "10BaseT" and "100BaseTX" with auto-negotiation
Auto-crossover	MDI / MDIX
Protocol supported	<ul style="list-style-type: none"> ● SoMachine Protocol ● Modbus Client/server ● Ethernet IP device ● FTP server ● HTTP server ● SNMP
IP address negotiation type supported	<ul style="list-style-type: none"> ● DHCP ● BOOTP ● Configured IP
Supplied current	No

Pin Assignment

The following figure shows the Ethernet connector pins:

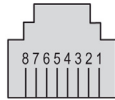

The following table describes the Ethernet connector pins:

Pin N°	Signal
1	TD+
2	TD-
3	RD+
4	-
5	-
6	RD-
7	-
8	-

NOTE: The controller supports the MDI/MDIX auto-crossover cable function. It is not necessary to use special Ethernet crossover cables to connect devices directly to this port (connections without an Ethernet hub or switch).

Status LEDs

The following figure shows the LEDs on the front panel display:

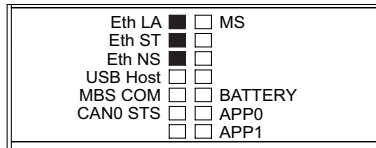

The following table describes the Ethernet status LEDs:

Marking	Description	LED	
		Color	Description
Eth LA	Ethernet Activity	Green / Yellow	See Ethernet status LED below
Eth ST	Ethernet Status	Green / Red	
Eth NS	Ethernet Network Status	Green / Red	

The following table describes the Ethernet status LED:

LED	Status	Description
Eth LA	Off	No link
	Flashing green / yellow	Power up testing. 3 flashes
	Solid green	Link at 100 Mbit/s
	Solid yellow	Link at 10 Mbit/s
	Flashing green	Activity at 100 Mbit/s
	Flashing yellow	Activity at 10 Mbit/s
Eth ST	Off	No cable connected, no IP address obtained
	Flashing green / red	Power up testing. 3 flashes
	Solid green	Port is connected and an IP address obtained
	3 flashes green	No cable connected, but the card has an IP address
	4 flashes green	Duplicated IP address detected
	5 flashes green	The card is performing a BOOTP or DHCP sequence
	6 flashes green	The configured IP is invalid. The default IP is used instead.
Eth NS	Off	The device does not have an IP address or is powered off
	Flashing green / red	Power up testing. 3 flashes
	Solid green	The device has at least one established connection
	Rapid flashing green	The device has not established connections but has obtained an IP address
	Rapid flashing red	One or more of the connections in which this device is the target has timed out.
	Solid red	The device has detected that its IP address is already in use. The controller Ethernet port can not communicate using this IP address.

CAN Port

Overview

The following figure shows the location of the CAN port of the controller:

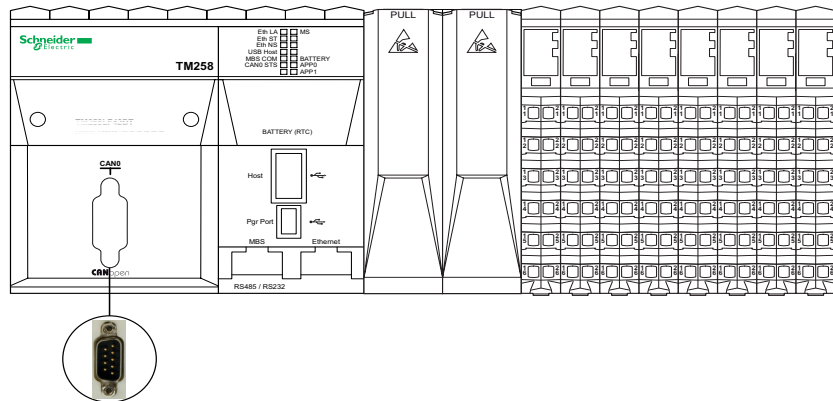

For more information, please refer to CANopen Hardware Setup Manual.

Capabilities

The protocol and function supported by the CAN port is CANopen.

Characteristics

The following table describes the CAN characteristics:

Characteristic	Description
Standard	CAN-CiA (ISO 11898-2:2002 Part 2) ¹
Connector type	Sub-D9, 9 pins male
Protocol supported	CANopen
CAN power distribution	No
Maximal cable length	See Transmission Speed and Cable - CANopen Hardware Setup Manual

Characteristic	Description
Isolation	See note ²
Bit rate	See table below ⁴
Line termination	No. See note ³

NOTE:

¹ Part 1 and Part 2 of ISO 11898:2002 are equivalent to ISO 11898:1993.

² The isolation of the electronic module is 500 Vac RMS between the electronics powered by TM5 power bus and the part powered by 24 Vdc I/O power segment connected to the module. In practice, the TM5 electronic module is installed in the bus base, and there is a bridge between TM5 power bus and 24 Vdc I/O power segment. The two power circuits reference the same functional ground (FE) through specific components designed to reduce effects of electromagnetic interference. These components are rated at 30 Vdc or 60 Vdc. This effectively reduces isolation of the entire system from the 500 Vac RMS.

³ A resistor (R) is needed on each end of the CAN field bus.

⁴ Maximum cable length is described in the following table:

Baud rate		1 Mbit/s	800 Kbit/s	500 Kbit/s	250 Kbit/s	125 Kbit/s	50 Kbit/s	20 Kbit/s	10 Kbit/s
Maximum cable length	m	4	25	100	250	500	1000	2500	5000
	ft.	13.12	82.02	328.08	820.20	1640.41	3280.83	8202.07	16404.15

Pin Assignment

The following graphic describes the pins of the CAN port:

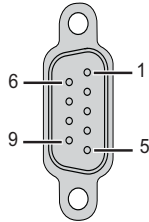

The following table describes the pins of the CAN port:

PIN N°	Signal	Description
1	N.C.	Reserved
2	CAN_L	CAN_L bus Line (Low)
3	CAN_GND	CAN 0 Vdc
4	N.C.	Reserved
5	CAN_SHLD	N.C.
6	GND	0 Vdc
7	CAN_H	CAN_H bus Line (High)
8	N.C.	Reserved
9	N.C.	Reserved

N.C.: Not Connected.

The shield is connected to pin 6, the 0 Vdc pin.

NOTE: Pin 9 is not connected internally. The controller does not provide power on CAN_V+.

WARNING

UNINTENDED EQUIPMENT OPERATION

Do not connect wires to unused terminals or terminals marked “Not Connected (N.C.)”.

Failure to follow these instructions can result in death, serious injury, or equipment damage.

Status LEDs

The following figure shows the LED on the front panel display:

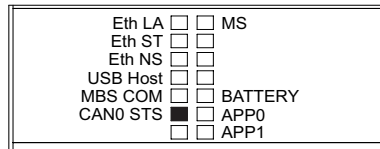

The following table describes the CAN status LED:

Marking	Description	LED	
		Color	Description
CAN0 STS	CAN 0 port status	Green / Red	See CAN0 STS status LED below

The following table describes the CAN0 STS status LED when the CAN 0 port is used as CANopen master:

CAN0 STS LED	CANopen Status	Description
OFF	No CANopen configured	CANopen is not active in the application
Single flash red / with green ON	Acceptable detected error limit threshold has been reached	The controller has detected that the maximum number of error frames has been reached or exceeded.
Double flash red / with green ON	Node Guarding or Heartbeat event	The controller has detected either a Node Guarding or Heartbeat exception for the CANopen master or slave device.
Red ON	Bus off	The CANopen bus is stopped
Green ON	The CANopen bus is operational	

For further details, please refer to the CANopen Hardware Setup Manual.

USB Programming Port

Overview

The following figure shows the location of the USB mini-B programming port of the controller:

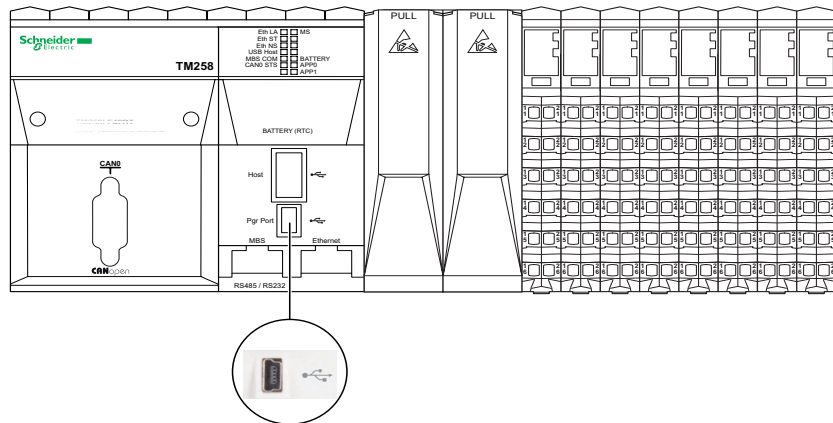

The USB Mini-B Port is the programming port you can use to connect a PC with a USB host port using SoMachine software. Using a typical USB cable, this connection is suitable for quick updates of the program or short duration connections to perform maintenance and inspect data values. It is not suitable for long term connections such as commissioning or monitoring without the use of specially adapted cables to help minimize electromagnetic interference.

⚠ WARNING

INOPERABLE EQUIPMENT OR UNINTENDED EQUIPMENT OPERATION

- You must use a shielded USB cable such as a BMX XCAUSBH0 secured to the functional ground (FE) of the system for any long term connection.
- Do not connect more than one controller at a time using USB connections.

Failure to follow these instructions can result in death, serious injury, or equipment damage.

Characteristics

The following table describes the characteristics for the USB Programming port:

Parameter	USB Programming Port
Standard	Hi-Speed USB 2.0 Device
Connector type	Mini-B
Maximum baud rate	480 Mbit/s
Protocol supported	<ul style="list-style-type: none">● SoMachine Protocol● FTP Server● HTTP Server
Supplied current	No
Maximum cable length	3 m (9.8 ft)
Isolation	None

USB Host Port

Overview

The following figure shows the location of the USB type A host port of the controller:

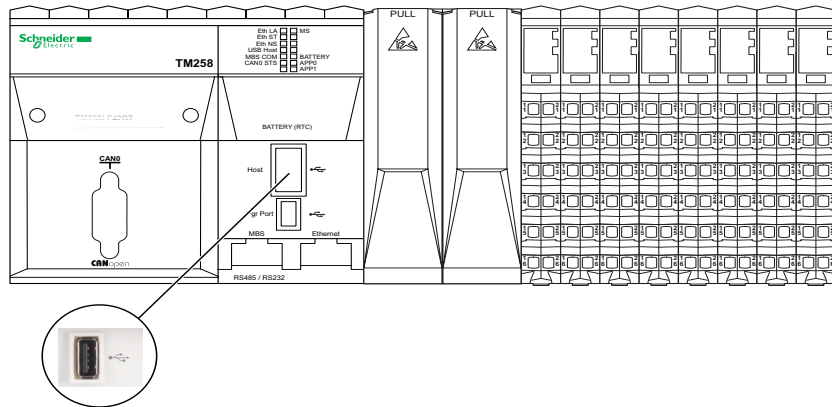

NOTE: The USB type A host port provides 500 mA continuous current (USB-standard) and 700 mA for short duration current spikes.

The Modicon M258 Logic Controller allows firmware updates and file transfers using a USB Memory Key. This makes it possible to perform device and data updates without the need for a SoMachine instance or the FTP Server.

The USB Host port can be used for upgrading the firmware and data files transfer with a USB Memory key.

For further details on firmware upgrades, please refer to Upgrading Controller Firmware (see *Modicon M258 Logic Controller, Programming Guide*).

For further details on data file transfers, please refer to File Transfer with USB Memory Key (see *Modicon M258 Logic Controller, Programming Guide*).

Characteristics

The following table describes the characteristics for the USB Host port:

Characteristic	Description
Standard	Hi-speed USB 2.0 Host
Connector type	A
Maximum baud rate	480 Mbit/s
Protocol supported	Mass Storage
Supplied current	5 Vdc USB Standard
Isolation	None

Status LED

The following figure shows the LEDs on the front panel display:

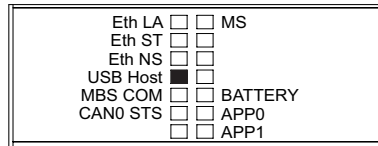

The following table describes the USB status LED:

Marking	Description	LED	
		Color	Description
USB Host	USB Host	Green / Red	<ul style="list-style-type: none"> ● Off when nothing is connected ● Rapid flashing green during exchange ● Solid green when no exchange ● Solid red for detected script error

Serial Line Port

Overview

The following figure shows the location of the Serial Line port of the controller:

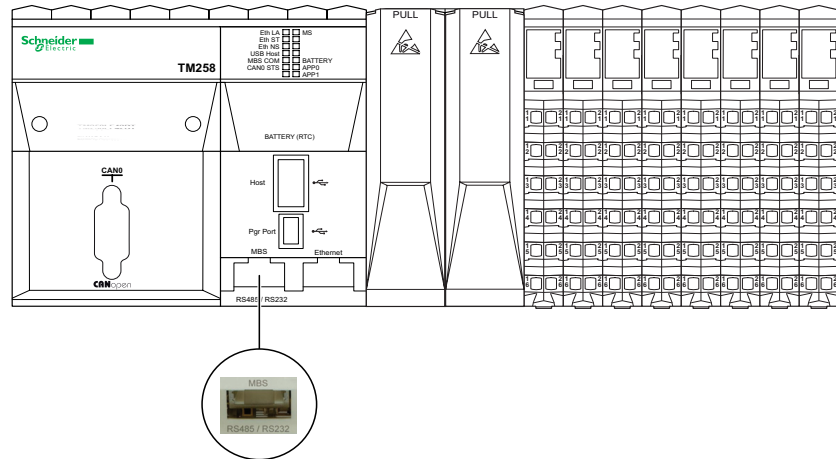

The serial line:

- is used to communicate with devices supporting the Modbus protocol as either master or slave, ASCII protocol (printer, modem...) and SoMachine Protocol (HMI,...).
- provides a 5 Vdc power distribution.

For further details, please refer to Serial Line - Planning and Installation.

Characteristics

Characteristic	Description
Standard	RS485 or RS232 software configured
Connector type	RJ45
Baud rate	300 up to 115 200 bps ²
Protocol supported	<ul style="list-style-type: none"> ● ASCII ● Modbus (RTU or ASCII) ● SoMachine
Device power distribution	5 Vdc / 200 mA
5 Vdc Protection	Withstands up to 24 Vdc
Isolation	See note ¹
Polarization	Two 560 Ω resistors switched on or off by software configuration

NOTE:

¹ The isolation of the electronic module is 500 Vac RMS between the electronics powered by TM5 power bus and the part powered by 24 Vdc I/O power segment connected to the module. In practice, the TM5 electronic module is installed in the bus base, and there is a bridge between TM5 power bus and 24 Vdc I/O power segment. The two power circuits reference the same functional ground (FE) through specific components designed to reduce effects of electromagnetic interference. These components are rated at 30 Vdc or 60 Vdc. This effectively reduces isolation of the entire system from the 500 Vac RMS.

² The maximum Baud rate for the Serial Line Port depends on the protocol used. For further information, refer to Serial Line Configuration (*see Modicon M258 Logic Controller, Programming Guide*).

Pin Assignment

The following figure shows the pins for RS485 and RS232:



The following table describes the pins for RS485 and RS232:

Pin	RS485	RS232
1	N.C.	RxD
2	N.C.	TxD
3	N.C.	RTS
4	D1 (A+)	N.C.

Pin	RS485	RS232
5	D0 (B-)	N.C.
6	N.C.	CTS
7	5 Vdc / 200 mA	5 Vdc / 200 mA
8	0 Vdc	0 Vdc

CTS: Clear To Send

N.C.: Not Connected

RTS: Ready To Send

RxD: Received Data

TxD: Transmitted Data

⚠ WARNING
UNINTENDED EQUIPMENT OPERATION
Do not connect wires to unused terminals or terminals marked “Not Connected (N.C.)”.
Failure to follow these instructions can result in death, serious injury, or equipment damage.

Status LED

The following figure shows the LEDs on the front panel display:

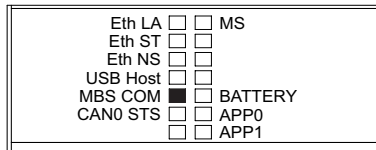

The following table describes the Serial line status LED:

Marking	Description	LED	
		Color	Description
MBS COM	Serial line port activity	Yellow	Rapid flashing when frames are received or transmitted

PCI Slots

12

PCI Slots

Overview

The following figure shows the location of the controller PCI slots:

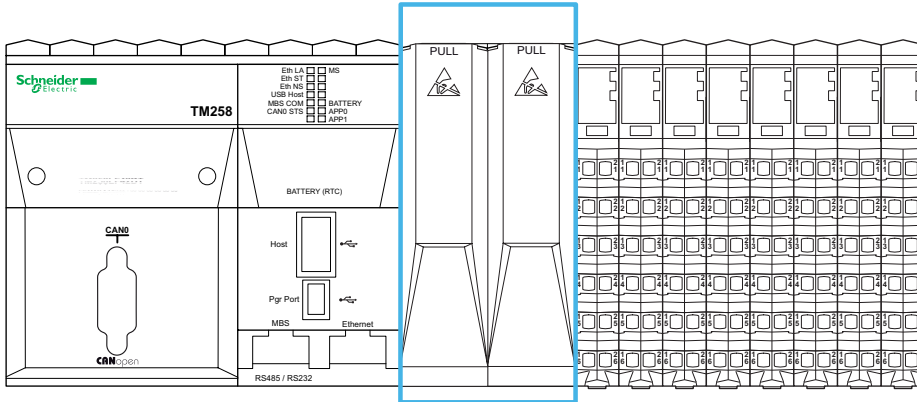

For more information, please refer to TM5 System General Rules for Implementing (see *Modicon TM5, PCI Modules, Hardware Guide*).

Description

The following figure shows the covers of the PCI slots found on the front of the controller:

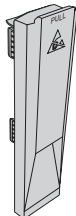

Compatibilities

There are two PCI slots to connect up to two interface modules depending on the controller reference.

The PCI modules are used for specific application expansions of the controller. They are inserted in the PCI slots of the controller:

Reference	Type	Description
TM5PCRS2	Serial line	TM5 interface electronic module, 1 RS232, electrically isolated
TM5PCRS4	Serial line	TM5 interface electronic module, 1 RS485, electrically isolated
TM5PCDPS	Profibus DP	TM5 interface electronic module, 1 RS485, electrically isolated

The following table describes the compatibilities between electronic modules and controllers:

Controllers	PCI Slots		
	TM5PCRS2	TM5PCRS4	TM5PCDPS
TM258LD42DT4L <i>(see page 49)</i>	OK	—	OK
TM5258LF42DT4L** <i>(see page 65)</i>	OK	—	OK
TM5258LF66DT4L** <i>(see page 73)</i>	—	OK	OK
TM5258LF42DR** <i>(see page 81)</i>	—	OK	OK

For further details about installing PCI modules, please refer to PCI Electronic Modules Installation *(see Modicon TM5, PCI Modules, Hardware Guide)*

NOTICE

ELECTROSTATIC DISCHARGE

- Ensure that empty PCI slots have their covers in place before applying power to the controller.
- Never touch an exposed PCI connector.

Failure to follow these instructions can result in equipment damage.

Embedded Expert I/O

13

Introduction

This chapter describes the embedded Expert I/O.

What's in this Chapter?

This chapter contains the following topics:

Topic	Page
Expert I/O	110
Fast Inputs Characteristics	115
Regular Inputs	118
Fast Outputs	120

Expert I/O

Overview

The following figure shows the location of the Expert I/O of the controller:

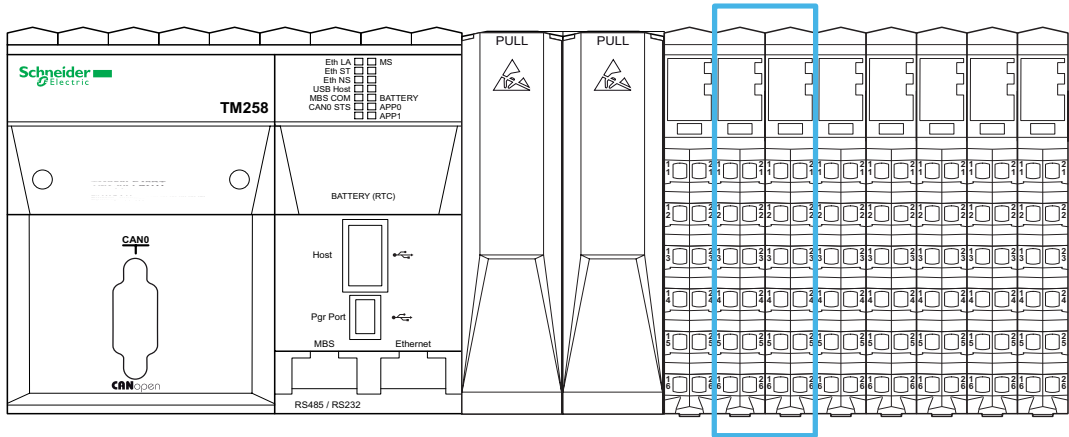

The controller has 2 modules of Embedded Expert I/O. Each module is comprised of:

- 5 fast inputs, 2 regular inputs and 2 fast outputs
- 3 commons

Advanced Functions

Expert I/O modules support the following advanced functions:

- High speed counter (HSC)
- Event input
- Latch input
- Run/Stop input
- Pulse width generator (PWM)
- Frequency generator
- Alarm output

Wiring Diagram

The following figure shows the wiring diagram of the expert I/O:

TM258LD42DT
TM258LF42DT●●

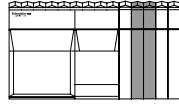

TM258LD42DT4L
TM258LF42DT4L●●

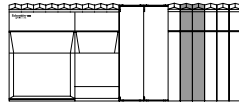

TM258LF66DT4L●●
TM258LF42DR●●

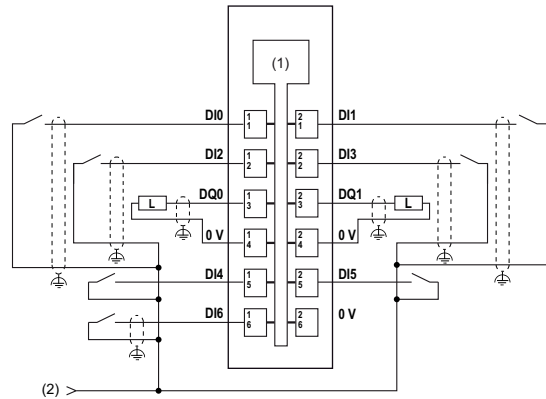
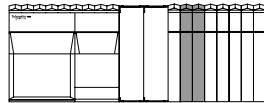

- 1 Internal electronics
- 2 24 Vdc Embedded expert modules power by external connection

The following figure shows the wiring diagram of the expert I/O with encoder:

TM258LD42DT
TM258LF42DT●●

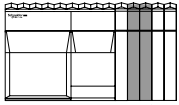

TM258LD42DT4L
TM258LF42DT4L●●

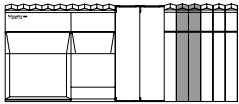

TM258LF66DT4L●●
TM258LF42DR●●

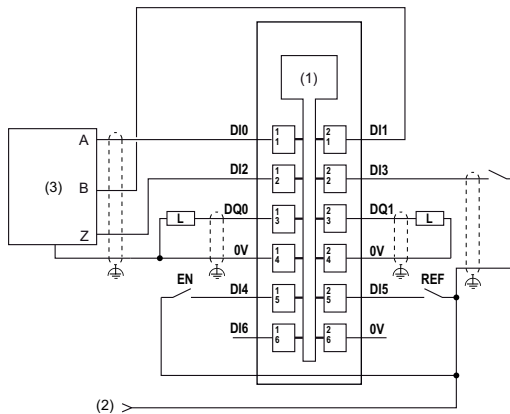
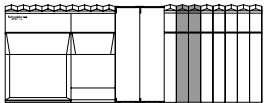

- 1 Internal electronics
- 2 24 Vdc Embedded expert modules power by external connection
- 3 Encoder

 WARNING

IMPROPER GROUNDING CAN CAUSE UNINTENDED EQUIPMENT OPERATION

- Use cables with insulated shielded jackets for analog I/O, fast I/O and communication signals.
- Ground shielded cables for analog I/O, fast I/O and communication signals at a single point ¹
- Always comply with local wiring requirements regarding grounding of cable shields.

Failure to follow these instructions can result in death, serious injury, or equipment damage.

NOTE: ¹Multipoint grounding is permissible if connections are made to an equipotential ground plane dimensioned to help avoid cable shield damage in the event of power system short circuit currents.

For more information, refer to the TM5 System Wiring Rules and Recommendation (*see page 17*).

 WARNING

UNINTENDED EQUIPMENT OPERATION

Do not connect wires to unused terminals or terminals marked “Not Connected (N.C.)”.

Failure to follow these instructions can result in death, serious injury, or equipment damage.

Status LEDs

The following figure shows the LEDs for the Expert I/O:

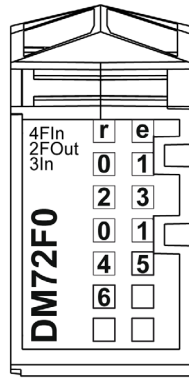

The table below describes the Expert I/O status LEDs:

LED	Color	Status	Description
r	Green	Off	No power supply
		Single Flash	Reset mode
		Flashing	Preoperational mode
		On	Normal operation
e	Red	Off	OK or no power supply
e+r	Steady red / single green flash		Invalid firmware
0-3	Green	On	Input status of the corresponding input 0...3
0-1	Yellow	On	Output status of the corresponding output 0...1
4-6	Green	On	Input status of the corresponding input 4...6

General Characteristics

WARNING

UNINTENDED EQUIPMENT OPERATION

Do not exceed any of the rated values specified in the following tables.

Failure to follow these instructions can result in death, serious injury, or equipment damage.

The following table describes the general characteristics of the embedded Expert modules:

General characteristics		
Input voltage range		19.2...28.8 Vdc
Rated voltage		24 Vdc
Isolation	Between channels and internal bus	See note ¹
	Between channels	Not isolated
Number of 0 Vdc commons		3 (internally connected)
24 Vdc I/O power segment current draw		17 mA
Internal power consumption		0.4 W max.

¹ The isolation of the electronic module is 500 Vac RMS between the electronics powered by TM5 power bus and the part powered by 24 Vdc I/O power segment connected to the module. In practice, the TM5 electronic module is installed in the bus base, and there is a bridge between TM5 power bus and 24 Vdc I/O power segment. The two power circuits reference the same functional ground (FE) through specific components designed to reduce effects of electromagnetic interference. These components are rated at 30 Vdc or 60 Vdc. This effectively reduces isolation of the entire system from the 500 Vac RMS.

Fast Inputs Characteristics

Input Characteristics

DANGER

FIRE HAZARD

Use only the recommended wire sizes for I/O channels and power supplies.

Failure to follow these instructions will result in death or serious injury.

WARNING

UNINTENDED EQUIPMENT OPERATION

Do not exceed any of the rated values specified in the following tables.

Failure to follow these instructions can result in death, serious injury, or equipment damage.

The following table describes the inputs characteristics of the fast inputs:

Input characteristics		
Number of fast inputs		5
Input signal type		Sink (see note ²)
Rated input current		4 mA
Input impedance		6 k Ω
Input type		Type 1 (IEC 61131-2)
OFF state 0 (voltage / current)		5 Vdc max. / 1.5 mA max.
ON state 1 (voltage / current)		15 Vdc min. / 2 mA min.
Integrator filtering		0 - 1.5 - 4 or 12 ms
Anti-bounce filtering		2 μ s...4 ms
Turn ON time		1 ms max.
Turn OFF time		1 ms max.
Isolation	Between channels and internal bus	See note ¹
	Between channels	Not isolated

Input characteristics	
Cable type	Shielded cable required
Cable length	5 m (16.4 ft.) max.

¹ The isolation of the electronic module is 500 Vac RMS between the electronics powered by TM5 power bus and the part powered by 24 Vdc I/O power segment connected to the module. In practice, the TM5 electronic module is installed in the bus base, and there is a bridge between TM5 power bus and 24 Vdc I/O power segment. The two power circuits reference the same functional ground (FE) through specific components designed to reduce effects of electromagnetic interference. These components are rated at 30 Vdc or 60 Vdc. This effectively reduces isolation of the entire system from the 500 Vac RMS.

² Connected to the 24 Vdc embedded Expert modules

Integrator Filter Principle

The integrator filter is designed to reduce the effect of noise. Setting a filter value allows the controller to ignore some sudden changes of input levels caused by noise.

The following timing diagram illustrates the integrator filter effects for a value of 4 ms:

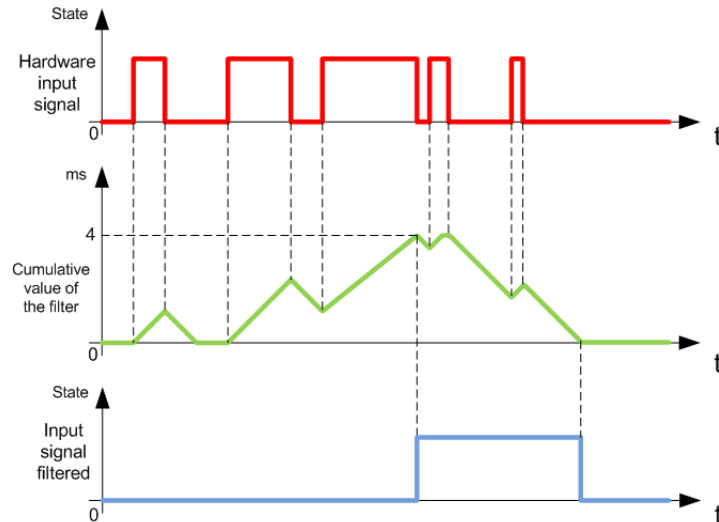

NOTE: The value selected for the filter's time parameter specifies the cumulative time in ms that must elapse before the input is recognized as logical 1, as well as specifying how long the filtered input signal remains at logical 1.

Bounce Filter Principle

The bounce filter is designed to reduce the bounce effect at the inputs. Setting a bounce filter value allows the controller to ignore some sudden changes of input levels caused by contact bounce. The bounce filter is only available on the fast inputs.

The following timing diagram illustrates the anti-bounce filter effects:

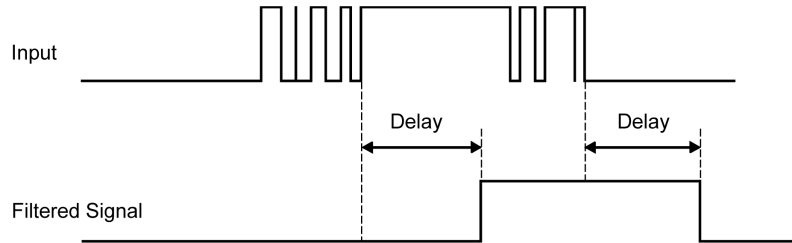

Regular Inputs

Input Characteristics

 **DANGER**

FIRE HAZARD

Use only the recommended wire sizes for I/O channels and power supplies.

Failure to follow these instructions will result in death or serious injury.

 **WARNING**

UNINTENDED EQUIPMENT OPERATION

Do not exceed any of the rated values specified in the following tables.

Failure to follow these instructions can result in death, serious injury, or equipment damage.

The following table describes the characteristics of the regular inputs:

Input characteristics	
Number of input channels	2
Input signal type	Sink (see note ²)
Rated input current	4 mA
Input impedance	6 k Ω
Input type	Type 1 (IEC 61131-2)
OFF state 0 (voltage / current)	5 Vdc max. / 1.5 mA max.
ON state 1 (voltage / current)	15 Vdc min. / 2 mA min.
Integrator filtering	0 - 1.5 - 4 or 12 ms

Input characteristics		
Isolation	Between channels and internal bus	See note ¹
	Between channels	Not isolated
Cable length		30 m (98.4 ft.) max.

¹ The isolation of the electronic module is 500 Vac RMS between the electronics powered by TM5 power bus and the part powered by 24 Vdc I/O power segment connected to the module. In practice, the TM5 electronic module is installed in the bus base, and there is a bridge between TM5 power bus and 24 Vdc I/O power segment. The two power circuits reference the same functional ground (FE) through specific components designed to reduce effects of electromagnetic interference. These components are rated at 30 Vdc or 60 Vdc. This effectively reduces isolation of the entire system from the 500 Vac RMS.

² Connected to the 24 Vdc embedded Expert modules

For further details on integrator filtering, please refer to Integrator Filter Principle (*see page 116*).

For further details on anti-bounce filtering, please refer to Bounce Filter Principle (*see page 117*).

Fast Outputs

Output Characteristics

⚠ DANGER
FIRE HAZARD
Use only the recommended wire sizes for I/O channels and power supplies.
Failure to follow these instructions will result in death or serious injury.

⚠ WARNING
UNINTENDED EQUIPMENT OPERATION
Do not exceed any of the rated values specified in the following tables.
Failure to follow these instructions can result in death, serious injury, or equipment damage.

For additional important information about fast output protection, refer to Protecting Outputs from Inductive Load Damage (see page 20).

The following table describes the characteristics of the fast outputs:

Output characteristics		
Number of fast outputs		2
Output signal type		Sink / Source
Output type		Push / pull
Rated Output current at 24 Vdc		0.5 A max.
Maximum switching frequency		0.2 A up to 25 KHz
		0.05 A up to 100 KHz
Protection against overload / short circuit		Yes (device becomes inoperable if current exceeds 0.625 A)
Delay time	From 0 to 1	2 μ s
	From 1 to 0	4 μ s
Isolation	Between channels	None (referenced to 0 Vdc of the 24 Vdc embedded expert modules power)
	Between output and internal bus	See note ¹

Output characteristics	
Cable type	Shielded cable required
Cable length	5 m (16.4 ft.) max.

¹ The isolation of the electronic module is 500 Vac RMS between the electronics powered by TM5 power bus and the part powered by 24 Vdc I/O power segment connected to the module. In practice, the TM5 electronic module is installed in the bus base, and there is a bridge between TM5 power bus and 24 Vdc I/O power segment. The two power circuits reference the same functional ground (FE) through specific components designed to reduce effects of electromagnetic interference. These components are rated at 30 Vdc or 60 Vdc. This effectively reduces isolation of the entire system from the 500 Vac RMS.

For further details on integrator filtering, please refer to Integrator Filter Principle (*see page 116*).

For further details on anti-bounce filtering, please refer to Bounce Filter Principle (*see page 117*).

Embedded Regular I/O

14

Introduction

This chapter describes the embedded regular I/O.

What's in this Chapter?

This chapter contains the following topics:

Topic	Page
Digital DI6DE	124
Digital DI12DE	127
Digital DO12TE	131
Analog AI4LE	136
Relay DO6RE	141

Digital DI6DE

Overview

The digital DI6DE electronic module is equipped with 6 sink inputs.

⚠ DANGER

FIRE HAZARD

Use only the recommended wire sizes for I/O channels and power supplies.

Failure to follow these instructions will result in death or serious injury.

⚠ WARNING

UNINTENDED EQUIPMENT OPERATION

Do not exceed any of the rated values specified in the following tables.

Failure to follow these instructions can result in death, serious injury, or equipment damage.

Input Characteristics

The table describes the input characteristics of the DI6DE electronic module:

Input Characteristics		
Number of input channels	6	
Wiring type	1 or 2 wires	
Input type	Type 1	
Signal type	Sink	
Rated input voltage	24 Vdc	
Input voltage range	20.4...28.8 Vdc	
Rated input current at 24 Vdc	3.75 mA	
Input impedance	6.4 kΩ	
OFF state	5 Vdc max.	
ON state	15 Vdc min.	
Input filter	Hardware	≤100 μs
	Software	Default 1 ms, can be configured between 0 and 25 ms in 0.2 ms intervals.

Input Characteristics		
Isolation	Between input and internal bus	See note ¹
	Between channels	Not isolated
24 Vdc I/O segment current draw		37 mA (all inputs On)

¹ The isolation of the electronic module is 500 Vac RMS between the electronics powered by TM5 power bus and the part powered by 24 Vdc I/O power segment connected to the module. In practice, the TM5 electronic module is installed in the bus base, and there is a bridge between TM5 power bus and 24 Vdc I/O power segment. The two power circuits reference the same functional ground (FE) through specific components designed to reduce effects of electromagnetic interference. These components are rated at 30 Vdc or 60 Vdc. This effectively reduces isolation of the entire system from the 500 Vac RMS.

Wiring Diagram

The following figure describes the wiring diagram of the DI6DE:

TM258LF42DR●●

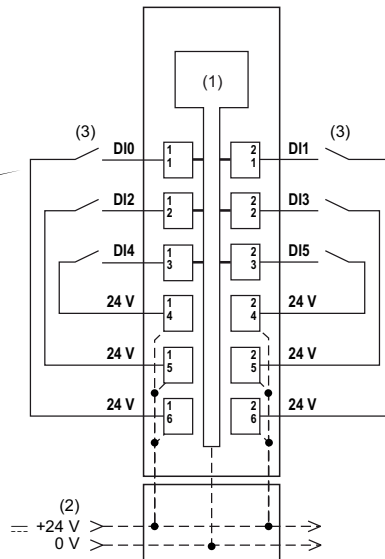
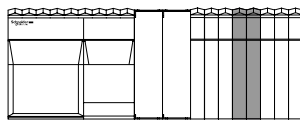

- 1 Internal electronics
- 2 24 Vdc I/O power segment integrated into the bus bases
- 3 2-wire sensor

⚠ WARNING

UNINTENDED EQUIPMENT OPERATION

Do not connect wires to unused terminals or terminals marked “Not Connected (N.C.)”.

Failure to follow these instructions can result in death, serious injury, or equipment damage.

Status LEDs

The following figure shows the LEDs for DI6DE:

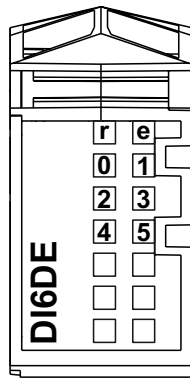

The table below shows the DI6DE status LEDs:

LEDs	Color	Status	Description
r	Green	Off	No power supply
		Single Flash	Reset mode
		Flashing	Preoperational mode
		On	Normal operation
e	Red	Off	OK or no power supply
e+r	Steady red / single green flash		Invalid firmware
0-5	Green	Off	Corresponding input deactivated
		On	Corresponding input activated

Digital DI12DE

Overview

The digital DI12DE module is equipped with 12 sink inputs.

DANGER

FIRE HAZARD

Use only the recommended wire sizes for I/O channels and power supplies.

Failure to follow these instructions will result in death or serious injury.

WARNING

UNINTENDED EQUIPMENT OPERATION

Do not exceed any of the rated values specified in the following tables.

Failure to follow these instructions can result in death, serious injury, or equipment damage.

Input Characteristics

The table below shows the characteristics of the DI12DE electronic module:

Characteristic		Value
Number of input channels		12
Wiring type		1 wire
Input type		Type 1
Signal type		Sink
Rated input voltage		24 Vdc
Input voltage range		20.4...28.8 Vdc
De-rating	55...60 °C (131...140 °F)	11 channels
Rated input current at 24 Vdc		3.75 mA
Input impedance		6.4 kΩ
OFF state		5 Vdc max.
ON state		15 Vdc min.
Input filter	Hardware	≤100 μs
	Software	Default 1 ms, can be configured between 0 and 25 ms in 0.2 ms intervals.

Characteristic		Value
Isolation	Between input and internal bus	See note ¹
	Between channels	Not isolated
24 Vdc I/O segment current draw		73 mA (all inputs On)

¹ The isolation of the electronic module is 500 Vac RMS between the electronics powered by TM5 power bus and the part powered by 24 Vdc I/O power segment connected to the module. In practice, the TM5 electronic module is installed in the bus base, and there is a bridge between TM5 power bus and 24 Vdc I/O power segment. The two power circuits reference the same functional ground (FE) through specific components designed to reduce effects of electromagnetic interference. These components are rated at 30 Vdc or 60 Vdc. This effectively reduces isolation of the entire system from the 500 Vac RMS.

Wiring Diagram

The following figure describes the wiring diagram of the DI12DE:

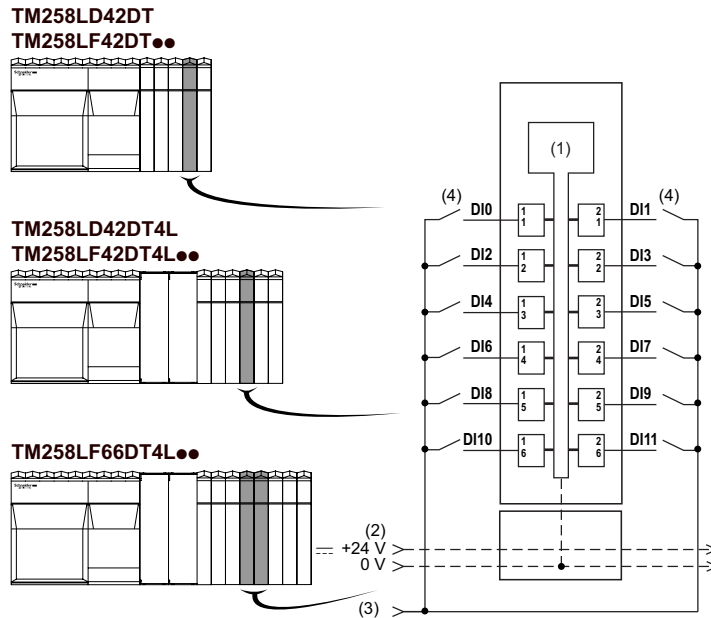

- 1 Internal electronics
- 2 24 Vdc I/O power segment integrated into the bus bases
- 3 24 Vdc I/O power segment by external connection
- 4 2-wire sensor

⚠ WARNING

POTENTIAL EXPLOSION OR FIRE

Connect the returns from the devices to the same power source as the 24 Vdc I/O power segment serving the module.

Failure to follow these instructions can result in death, serious injury, or equipment damage.

⚠ WARNING

UNINTENDED EQUIPMENT OPERATION

Do not connect wires to unused terminals or terminals marked “Not Connected (N.C.)”.

Failure to follow these instructions can result in death, serious injury, or equipment damage.

Status LEDs

The following figure shows the LEDs for DI12DE:

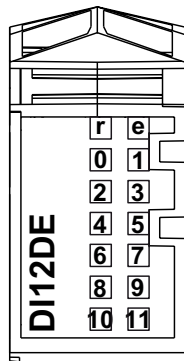

The table below shows the DI12DE status LEDs:

LEDs	Color	Status	Description
r	Green	Off	No power supply
		Single Flash	Reset mode
		Flashing	Preoperational mode
		On	Normal operation
e	Red	Off	OK or no power supply
e+r	Steady red / single green flash		Invalid firmware
0-11	Green	Off	Corresponding input deactivated
		On	Corresponding input activated

Digital DO12TE

Overview

The digital DO12TE electronic module is equipped with 12 source outputs.

DANGER

FIRE HAZARD

Use only the recommended wire sizes for I/O channels and power supplies.

Failure to follow these instructions will result in death or serious injury.

WARNING

UNINTENDED EQUIPMENT OPERATION

Do not exceed any of the rated values specified in the following tables.

Failure to follow these instructions can result in death, serious injury, or equipment damage.

Output Characteristics

For additional important information about fast output protection, refer to Protecting Outputs from Inductive Load Damage (*see page 20*).

The following table describes the characteristics of the DO12TE electronic module:

Characteristic	Value
Output channels	12
Wiring type	1 wire
Output type	Transistor
Signal type	Source
Output current	0.5 A max. per output
Total output current	6 A max.
Rated output voltage	24 Vdc
Output voltage range	20.4 ... 28.8 Vdc
De-rating at 60° C (140° F)	I=0.4 A max. by channel
Voltage drop	0.3 Vdc max. at 0.5 A rated current
Diagnostic status	Output monitoring with 10 ms delay
Leakage current when switched off	5 µA
Turn on time	300 µs max.

Characteristic		Value
Turn off time		300 μ s max.
Output protection		Against short-circuit and overload, thermal protection
Short circuit output peak current		12 A max.
Automatic rearming after short circuit or overload		Yes, 10 ms min. depending on internal temperature
Protection against reverse polarity		Yes
Clamping voltage		Typ. 50 Vdc
Switching frequency	Resistive load	500 Hz Max.
	Inductive load	See the switching inductive load characteristics (<i>see page 133</i>)
Isolation	Between input and internal bus	See note ¹
	Between channels	Not isolated
24 Vdc I/O segment current draw		48 mA

¹ The isolation of the electronic module is 500 Vac RMS between the electronics powered by TM5 power bus and the part powered by 24 Vdc I/O power segment connected to the module. In practice, the TM5 electronic module is installed in the bus base, and there is a bridge between TM5 power bus and 24 Vdc I/O power segment. The two power circuits reference the same functional ground (FE) through specific components designed to reduce effects of electromagnetic interference. These components are rated at 30 Vdc or 60 Vdc. This effectively reduces isolation of the entire system from the 500 Vac RMS.

Switching Inductive Load

The following curves provide the switching inductive load characteristics for the DO12TE electronic module.

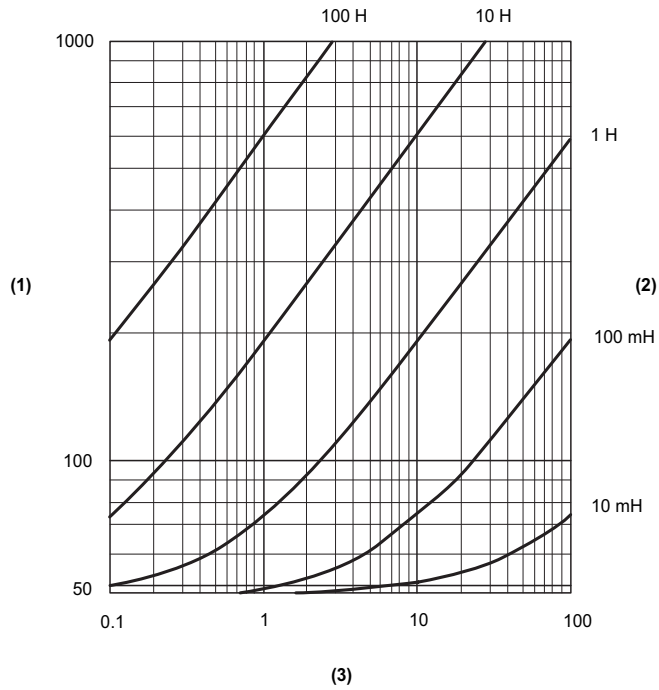

- 1 Coil resistance in Ω
- 2 Coil inductance
- 3 Max. operating cycles / second

Wiring Diagram

The following figure shows the wiring diagram of the DO12TE:

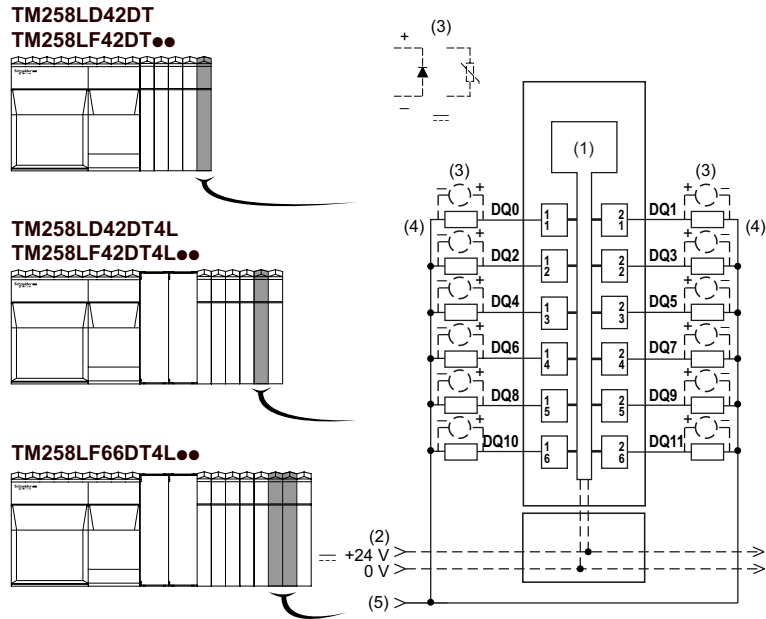

- 1 Internal electronics
- 2 24 Vdc I/O power segment integrated into the bus bases
- 3 Inductive load protection
- 4 2-wire load
- 5 0 Vdc I/O power segment by external connection

⚠ WARNING

POTENTIAL EXPLOSION OR FIRE

Connect the returns from the devices to the same power source as the 24 Vdc I/O power segment serving the module.

Failure to follow these instructions can result in death, serious injury, or equipment damage.

⚠ WARNING

UNINTENDED EQUIPMENT OPERATION

Do not connect wires to unused terminals or terminals marked “Not Connected (N.C.)”.

Failure to follow these instructions can result in death, serious injury, or equipment damage.

Status LEDs

The following figure shows the LEDs for DO12TE:

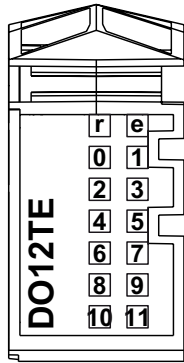

The following table describes the DO12TE status LEDs:

LEDs	Color	Status	Description
r	Green	Off	No power supply
		Single Flash	Reset mode
		Flashing	Preoperational mode
		On	Normal operation
e	Red	Off	OK or no power supply
		Single flash	Detected error for an output channel
e+r	Steady Red / Single Green flash		Invalid firmware
0- 11	Yellow	Off	Corresponding output deactivated
		On	Corresponding output activated

Analog AI4LE

Overview

The analog AI4LE electronic module is equipped with 4 12-bit inputs.

 **DANGER**

FIRE HAZARD

Use only the recommended wire sizes for I/O channels and power supplies.

Failure to follow these instructions will result in death or serious injury.

 **WARNING**

UNINTENDED EQUIPMENT OPERATION

Do not exceed any of the rated values specified in the following tables.

Failure to follow these instructions can result in death, serious injury, or equipment damage.

Input Characteristics

The following table describes the characteristics of the AI4LE electronic module:

Characteristic	Voltage input	Current input
Number of input channels	4	
Input range	-10... +10 Vdc	0...20 mA / 4...20 mA
Input impedance	20 M Ω min.	-
Load impedance	-	400 Ω max.
Sample duration time	400 μ s for all inputs without filtering 1 ms for all inputs with filtering	
Input type	Differential	
Conversion mode	Successive Approximative Register	
Input filter	Low pass 3rd order / cut-off frequency 1 kHz	
Input tolerance - maximum deviation at ambient 25° C (77° F)	< 0.08% of the measurement	< 0.08% of the measurement
Input tolerance - temperature drift	0.006% / °C of the measurement	0.009% / °C of the measurement
Input tolerance - non linearity	< 0.025% of the full scale (20 V)	< 0.05% of the full scale (20 mA)
Digital resolution	12 bit + sign	12 bit

Characteristic	Voltage input	Current input
Resolution value	2.441 mV	4.883 μ A
Common mode rejection	DC	70 dB min.
	50 Hz	70 dB min.
Cable type	Shielded cable required	
Crosstalk rejection between channels	70 dB min.	
Isolation between channels	Not isolated	
Isolation between channels and bus	See note ¹ .	
Permitted input signal	± 30 Vdc max.	± 50 mA max.
Input protection	Protection against wiring with 24 Vdc supply voltage	
Common mode voltage allowable between channels	± 12 Vdc max.	
24 Vdc I/O power segment current draw	48 mA	

¹ The isolation of the electronic module is 500 Vac RMS between the electronics powered by TM5 power bus and the part powered by 24 Vdc I/O power segment connected to the module. In practice, the TM5 electronic module is installed in the bus base, and there is a bridge between TM5 power bus and 24 Vdc I/O power segment. The two power circuits reference the same functional ground (FE) through specific components designed to reduce effects of electromagnetic interference. These components are rated at 30 Vdc or 60 Vdc. This effectively reduces isolation of the entire system from the 500 Vac RMS.

Wiring Diagram

The following figure shows the wiring diagram of the AI4LE:

TM258LD42DT4L
TM258LF42DT4L●●

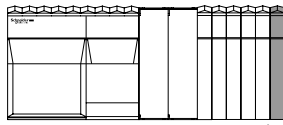

TM258LF66DT4L●●

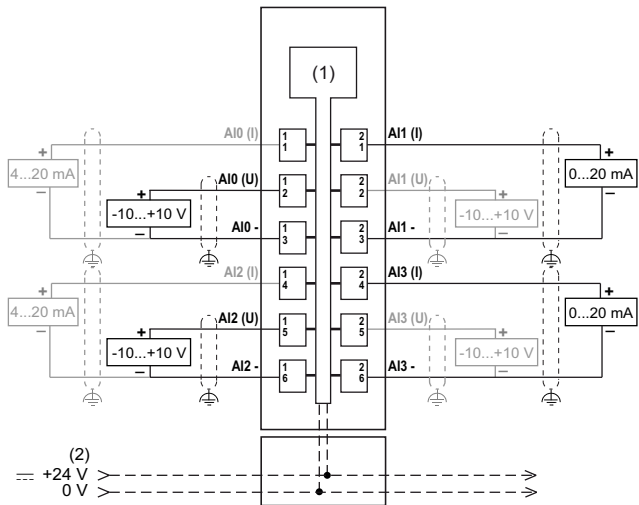
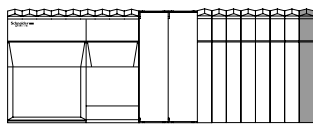

- 1 Internal electronics
- 2 24 Vdc I/O power segment integrated into the bus bases
- I Current
- U Voltage

⚠ WARNING

IMPROPER GROUNDING CAN CAUSE UNINTENDED EQUIPMENT OPERATION

- Use cables with insulated shielded jackets for analog I/O, fast I/O and communication signals.
- Ground shielded cables for analog I/O, fast I/O and communication signals at a single point ¹
- Always comply with local wiring requirements regarding grounding of cable shields.

Failure to follow these instructions can result in death, serious injury, or equipment damage.

NOTE: ¹Multipoint grounding is permissible if connections are made to an equipotential ground plane dimensioned to help avoid cable shield damage in the event of power system short circuit currents.

For more information, refer to the TM5 System Wiring Rules and Recommendation (see page 17).

⚠ WARNING**UNINTENDED EQUIPMENT OPERATION**

Do not connect wires to unused terminals or terminals marked “Not Connected (N.C.)”.

Failure to follow these instructions can result in death, serious injury, or equipment damage.

If you have physically wired, for example, your analog module channel for a voltage signal, and you configure the channel for a current signal in SoMachine, you may damage the analog module.

NOTICE**INOPERABLE EQUIPMENT**

Be sure that the physical wiring of the module is compatible with the software configuration for the module.

Failure to follow these instructions can result in equipment damage.

Status LEDs

The following figure shows LEDs for AI4LE:

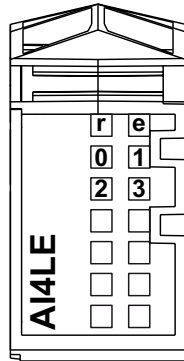

The following table describes the AI4LE status LEDs:

LEDs	Color	Status	Description
r	Green	Off	No power supply
		Single Flash	Reset mode
		Flashing	Preoperational mode
		On	Normal operation
e	Red	Off	OK or no power supply
		On	Detected error or reset state
		Double Flash	System detected error: <ul style="list-style-type: none"> ● Scan time overrun ● Synchronization detected error
0-3	Green	Off	Open connection or sensor is disconnected
		On	The analog/digital converter is running, value is available

Relay DO6RE

Overview

The relay DO6RE electronic module is equipped with 6 relay outputs.

DANGER

FIRE HAZARD

Use only the recommended wire sizes for I/O channels and power supplies.

Failure to follow these instructions will result in death or serious injury.

WARNING

UNINTENDED EQUIPMENT OPERATION

Do not exceed any of the rated values specified in the following tables.

Failure to follow these instructions can result in death, serious injury, or equipment damage.

Durability Electric

The curves below provide the expected life of the relay contacts for the DO6RE electronic module.

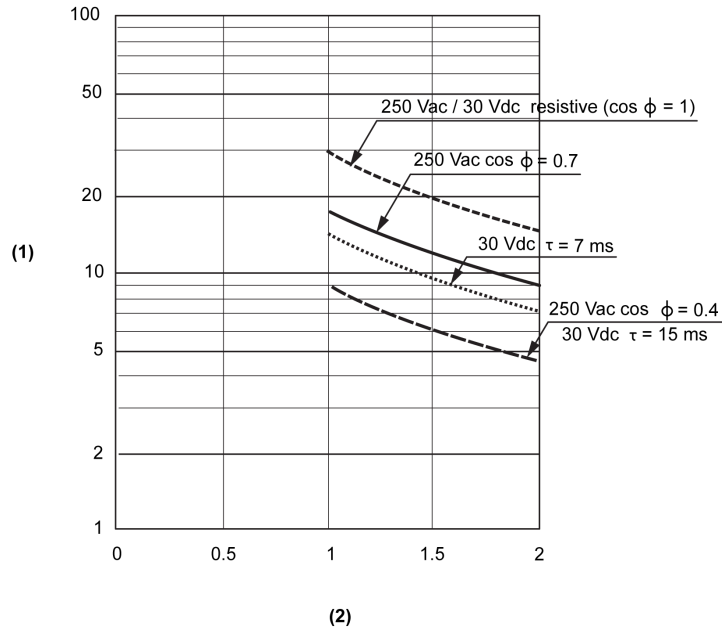

- 1 Switching procedures ($\times 10^4$)
- 2 Switching current in A

Output Characteristics

The table below describes the characteristics of DO6RE electronic module:

Characteristic	Value
Output channels	6
Wiring type	6 contacts
Contact type	NO (Normally Open)
Output current	24 Vdc / 2 A (Resistive load) 240 Vac / 2 A (cos Φ = 1)
Switching frequency	3600 cycles by hour max.
Relay dielectric maximum voltage	2000 V rms, 50/60 Hz for 1 mn
Maximum switching load	264 Vac / 125 Vdc
Minimum switching load	5 Vdc at 1 mA
Maximum power of filament lamp	1.2 W

Characteristic		Value
Turn on time		12 ms max.
Turn off time		10 ms max.
Protective circuit ²	Internal	None
	External DC AC	Flyback diode, RC combination or Varistor RC combination or Varistor
Automatic rearming after short circuit or overload		Yes, 10 ms min. depending on internal temperature
Switching capacity	Minimum	10 mA at 5 Vdc
	Maximum	150 W / 1250 VA
Protection against reverse polarity		Yes
Isolation	Between channels and bus	See note ¹
	Between outputs	Not isolated
Mechanical durability		Typically 2×10^7 cycles or more
24 Vdc I/O segment current draw		0 mA

¹ Refer to Protecting Outputs from Inductive Load Damage (*see page 20*) for additional important information on this topic.

² The isolation of the electronic module is 500 Vac RMS between the electronics powered by TM5 power bus and the part powered by 24 Vdc I/O power segment connected to the module. In practice, the TM5 electronic module is installed in the bus base, and there is a bridge between TM5 power bus and 24 Vdc I/O power segment. The two power circuits reference the same functional ground (FE) through specific components designed to reduce effects of electromagnetic interference. These components are rated at 30 Vdc or 60 Vdc. This effectively reduces isolation of the entire system from the 500 Vac RMS.

Wiring Diagram

The following figure describes the wiring diagram of the DO6RE:

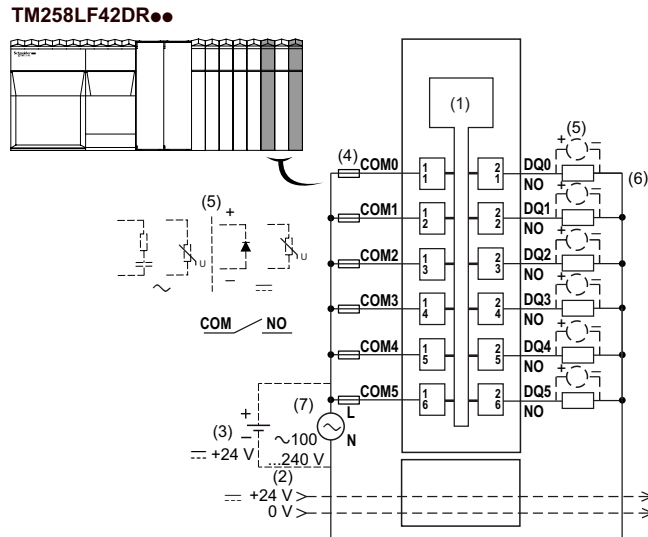

- 1 Internal electronics
- 2 24 Vdc I/O power segment integrated into the bus bases
- 3 External isolated power supply 24 Vdc
- 4 External fuse type T slow-blow 2 A 250 Vac
- 5 Inductive load protection
- 6 2-wire load
- 7 External power supply 100...240 Vac

⚠ WARNING

POTENTIAL OF OVERHEATING AND FIRE

- Do not connect the modules directly to line voltage.
- Use only isolating PELV or SELV power supplies to supply power to the modules.

Failure to follow these instructions can result in death, serious injury, or equipment damage.

⚠ WARNING

UNINTENDED EQUIPMENT OPERATION

Do not connect wires to unused terminals or terminals marked “Not Connected (N.C.)”.

Failure to follow these instructions can result in death, serious injury, or equipment damage.

NOTE: Refer to Protecting Outputs from Inductive Load Damage (*see page 20*) for additional important information on this topic.

Status LEDs

The following figure shows the LEDs for DO6RE:

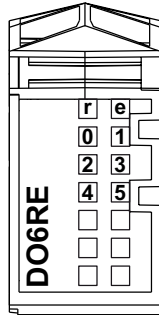

The table below shows the DO6RE status LEDs:

LEDs	Color	Status	Description
r	Green	Off	No power supply
		Single Flash	Reset mode
		Flashing	Preoperational mode
		On	Normal operation
e	Red	Off	OK or no power supply
		On	Detected error or reset state
e+r	Steady red / single green flash		Invalid firmware
0-5	Green	Off	Corresponding output deactivated
		On	Corresponding output activated

Connecting the Modicon M258 Logic Controller to a PC

15

Connecting the Controller to a PC

Overview

To transfer, run and monitor the applications, connect the controller to a computer, that has SoMachine installed, use either a USB cable or an Ethernet connection.

<i>NOTICE</i>
INOPERABLE EQUIPMENT
Always connect the communication cable to the PC before connecting it to the controller.
Failure to follow these instructions can result in equipment damage.

USB Mini-B Port Connection

TSX CNA MUM3P : This USB cable is suitable for short duration connection like quick updates or retrieving data values.

BMX XCA USBH045 : Grounded and shielded, this USB cable is suitable for long duration connection.

NOTE: You can only connect 1 controller to the PC at the same time.

The USB Mini-B Port is the programming port you can use to connect a PC with a USB host port using SoMachine software. Using a typical USB cable, this connection is suitable for quick updates of the program or short duration connections to perform maintenance and inspect data values. It is not suitable for long term connections such as commissioning or monitoring without the use of specially adapted cables to help minimize electromagnetic interference.

⚠ WARNING

INOPERABLE EQUIPMENT OR UNINTENDED EQUIPMENT OPERATION

- You must use a shielded USB cable such as a BMX XCAUSBH0** secured to the functional ground (FE) of the system for any long term connection.
- Do not connect more than one controller at a time using USB connections.

Failure to follow these instructions can result in death, serious injury, or equipment damage.

The communication cable should be connected to the PC first to minimize the possibility of electrostatic discharge affecting the controller.

The following figure shows the USB connection to a PC:

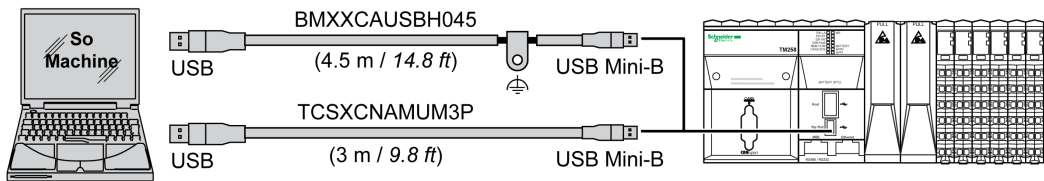

To connect the USB cable to your controller, do the following:

Step	Action
1	<p>1a If making a long term connection using the cable BMX XCA USBH045, or other cable with a ground shield connection, be sure to securely connect the shield connector to the functional ground (FE) or protective ground (PE) of your system before connecting the cable to your controller and your PC.</p> <p>1b If making a short term connection using the cable TSX CNA MUM3P or other non-grounded USB cable, proceed to step 2.</p>
2	Connect the USB cable connector to the PC.
3	Connect the Mini connector of your USB cable to the controller USB connector.

Ethernet Port Connection

You can also connect the controller to a PC using an Ethernet cable.

The following figure shows the Ethernet connection to a PC:

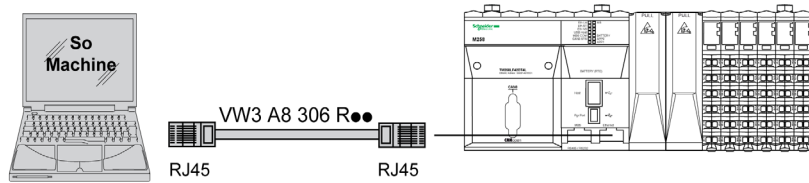

To connect the controller to the PC, do the following:

Step	Action
1	Connect your Ethernet cable to the PC.
2	Connect your Ethernet cable to the Ethernet port on the controller.

Glossary

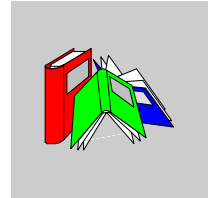

A

analog input

An *analog input* module contains circuits that convert an analog DC input signal to a digital value that can be manipulated by the processor. By implication, the analog input is usually direct. That means a data table value directly reflects the analog signal value.

analog output

An *analog output* module contains circuits that transmit an analog DC signal proportional to a digital value input to the module from the processor. By implication, these analog outputs are usually direct. That means a data table value directly controls the analog signal value.

AWG

The *american wire gauge* standard specifies wire gauges in North America.

B

bus base

A *bus base* is a mounting device that is designed to seat an electronic module on a DIN rail and connect it to the TM5 bus for M258 and LMC058 controllers. Each base bus extends the TM5 data and to the power buses and the 24 Vdc I/O power segment. The electronic modules are added to the TM5 system through their insertion on the base bus. The base bus also supplies the articulation point for the terminal blocks.

C

CAN

The *controller area network* protocol (ISO 11898) for serial bus networks is designed for the interconnection of smart devices (from multiple manufacturers) in smart systems for real-time industrial applications. CAN multimaster systems help ensure high data integrity through the implementation of broadcast messaging and advanced diagnostic mechanisms. Originally developed for use in automobiles, CAN is now used in a variety of industrial automation control environments.

CANopen

CANopen is an open industry-standard communication protocol and device profile specification.

compact I/O module

A *compact I/O module* is an indissociable group of five analog and/or digital I/O electronic modules in a single reference.

configuration

The *configuration* includes the arrangement and interconnection of hardware components within a system and the hardware and software selections that determine the operating characteristics of the system.

controller

A *controller* (or “programmable logic controller,” or “programmable controller”) is used to automate industrial processes.

CPDM

controller power distribution module

CSA

The *canadian standards association* defines and maintains standards for industrial electronic equipment in hazardous environments.

CTS

Clear to send is a data transmission signal and acknowledges the RDS signal from the transmitting station.

D

De-rating

De-rating describes a reduction in an operating specification. For devices in general it is usually a specified reduction in nominal power to facilitate operation at increased ambient conditions like higher temperatures or higher altitudes.

DHCP

The *dynamic host configuration protocol* is an advanced extension of BOOTP. DHCP is a more advanced, but both DHCP and BOOTP are common. (DHCP can handle BOOTP client requests.)

digital I/O

A *digital input or output* has an individual circuit connection at the electronic module that corresponds directly to a data table bit that holds the value of the signal at that I/O circuit. It gives the control logic digital access to I/O values.

DIN

Deutsches Institut für Normung is a German institution that sets engineering and dimensional standards.

E

electronic module

In a programmable controller system, most electronic modules directly interface to the sensors, actuators, and external devices of the machine/process. This electronic module is the component that mounts in a bus base and provides electrical connections between the controller and the field devices. Electronic modules are offered in a variety of signal levels and capacities. (Some electronic modules are not I/O interfaces, including power distribution modules and transmitter/receiver modules.)

EN

EN identifies one of many European standards maintained by CEN (*European Committee for Standardization*), CENELEC (*European Committee for Electrotechnical Standardization*), or ETSI (*European Telecommunications Standards Institute*).

encoder

An *encoder* is a device for length or angular measurement (linear or rotary encoders).

Ethernet

Ethernet is a physical and data link layer technology for LANs, also known as IEE 802.3.

expansion bus

The *expansion bus* is an electronic communication bus between expansion modules and a CPU.

expert I/O

Expert I/Os are dedicated modules or channels for advanced features. These features are generally embedded in the module in order to not use the resources of the PLC Controller and to allow a fast response time, depending of the feature. Regarding the function, it could be considered as a “stand alone” module, because the function is independent of the Controller processing cycle, it just exchanges some information with the Controller CPU.

F

FAST I/O

FAST I/Os are specific I/Os with some electrical features (response time, for example) but the treatment of these channels is done by the Controller CPU.

FE

Functional ground is the point of a system or device that must be grounded to help prevent equipment damage.

FG

frequency generator

firmware

The *firmware* represents the operating system on a controller.

H

hot swapping

Hot swapping is the replacement of a component with a like component while the system remains operational. The replacement component begins to function automatically after it is installed.

HSC

high-speed counter.

I

I/O

input/output

IEC

The *international electrotechnical commission* is a non-profit and non-governmental international standards organization that prepares and publishes international standards for all electrical, electronic, and related technologies.

input filter

An *input filter* is a special function that rejects input noises. It is useful for helping to minimize input noises and chatter in limit switches. All inputs provide a level of input filtering using the hardware. Additional filtering with software is also configurable through the programming or the configuration software.

IP 20

Ingress protection rating according to IEC 60529. IP20 modules are protected against ingress and contact of objects larger than 12.5 mm. The module is not protected against harmful ingress of water.

L

LED

A *light emitting diode* is an indicator that lights up when electricity passes through it.

M

Modbus

The Modbus communication protocol allows communications between many devices connected to the same network.

N

NC

A *normally closed* contact is a contact pair that is closed when the actuator is de-energized (no power is applied) and open when the actuator is energized (power is applied).

network

A network includes interconnected devices that share a common data path and protocol for communications.

P

PCI

A *peripheral component interconnect* is an industry-standard bus for attaching peripherals.

PDM

A *power distribution module* distributes either AC or DC field power to a cluster of I/O modules.

PE

Protective ground is a return line across the bus for fault currents generated at a sensor or actuator device in the control system.

Profibus DP

Profibus Decentralised Peripheral is a linear bus with a centralized access procedure of the Master/Slave type. Only Master stations, also known as active stations, have access rights to the bus. The Slave or passive stations can only respond to prompts. The physical connection is a single shielded twisted pair, but fiber optic interfaces are available to create tree, star, or ring structures. Compared to the ISO model, only layers 1, 2 are implemented, since access from the user interface is made directly to the link layer via simple mapping of variables.

Pt100/Pt1000

Platinum resistance thermometer are characterized by their nominal resistance R_0 at a temperature of 0°C .

- Pt100 ($R_0 = 100 \text{ Ohm}$)
- Pt1000 ($R_0 = 1 \text{ kOhm}$)

PWM

Pulse width modulation is used for regulation processes (e.g. actuators for temperature control) where a pulse signal is modulated in its length. For these kind of signals, transistor outputs are used.

R**RS-232**

RS-232 (also known as EIA RS-232C or V.24) is a standard type of serial communication bus, based on three wires.

RS-485

RS-485 (also known as EIA RS-485) is a standard type of serial communication bus, based on two wires.

RTS

Request to send is a data transmission signal and will be acknowledged by the CTS signal from the destination node.

RxD

receiving data (data transmission signal)

S

SEL-V

A system that follows IEC 61140 guidelines for *safety extra low voltage* is protected in such a way that voltage between any 2 accessible parts (or between 1 accessible part and the PE terminal for Class 1 equipment) does not exceed a specified value under normal conditions or under single-fault conditions.

sink input

A *sink input* is a wiring arrangement in which the device provides current to the input electronic module. A sink input is referenced to 0 Vdc.

SL

serial line

source output

A *source output* is a wiring arrangement in which the output electronic module provides current to the device. A source output is referenced to +24 Vdc.

T

terminal block

The *terminal block* is the component that mounts in an electronic module and provides electrical connections between the controller and the field devices.

TxD

TxD represents a transmit signal.

U

UL

Underwriters laboratories, US organization for product testing and safety certification.

Index

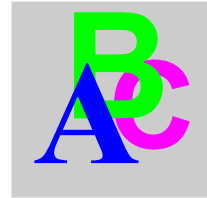

A

Analog AI4LE, *136*

C

CAN Port, *95*
Communication Ports, *91*

D

Digital DI12DE, *127*
Digital DI6DE, *124*
Digital DO12TE, *131*

E

environmental characteristics, *23*
Ethernet Port, *92*
Expert I/O, *110*

F

Fast Inputs Characteristics, *115*
Fast Outputs, *120*
First Startup, *39*

I

installation
installation requirements, *14*

M

M258
TM258LD42DT, *41*
TM258LD42DT4L, *49*
TM258LF42DR••, *81*
TM258LF42DT••, *57*
TM258LF42DT4L••, *65*
TM258LF66DT4L••, *73*

P

PCI Slots, *107*
Pin Assignment
CAN Port (CAN 0 or CAN 1), *97*
Serial Line Port, *104*

S

Serial Line Port, *103*
Startup procedure
First Startup, *39*
Status LED
Serial Line Port, *105*
USB Host Port, *102*
Status LEDs
CAN Ports, *98*
Ethernet Port, *93*

T

TM258LD42DT, *41*
TM258LD42DT4L, *49*

TM258LF42DR••, 81
TM258LF42DT••, 57
TM258LF42DT4L••, 65
TM258LF66DT4L••, 73

U

USB Host Port, 101
USB Programming Port, 99

W

wiring rules, 17