

Altivar Soft Starter ATS490

Soft Starter for Asynchronous Motors

EtherNet Manual

PKR63423.01

12/2024



Legal Information

The information provided in this document contains general descriptions, technical characteristics and/or recommendations related to products/solutions.

This document is not intended as a substitute for a detailed study or operational and site-specific development or schematic plan. It is not to be used for determining suitability or reliability of the products/solutions for specific user applications. It is the duty of any such user to perform or have any professional expert of its choice (integrator, specifier or the like) perform the appropriate and comprehensive risk analysis, evaluation and testing of the products/solutions with respect to the relevant specific application or use thereof.

The Schneider Electric brand and any trademarks of Schneider Electric SE and its subsidiaries referred to in this document are the property of Schneider Electric SE or its subsidiaries. All other brands may be trademarks of their respective owner.

This document and its content are protected under applicable copyright laws and provided for informative use only. No part of this document may be reproduced or transmitted in any form or by any means (electronic, mechanical, photocopying, recording, or otherwise), for any purpose, without the prior written permission of Schneider Electric.

Schneider Electric does not grant any right or license for commercial use of the document or its content, except for a non-exclusive and personal license to consult it on an "as is" basis.

Schneider Electric reserves the right to make changes or updates with respect to or in the content of this document or the format thereof, at any time without notice.

To the extent permitted by applicable law, no responsibility or liability is assumed by Schneider Electric and its subsidiaries for any errors or omissions in the informational content of this document, as well as any non-intended use or misuse of the content thereof.

Table of Contents

Safety Information	5
About the Book.....	11
Validity note.....	11
Document Scope	11
Related Documents	12
Electronic product data sheet.....	13
Terminology.....	14
Structure of the Parameter Table.....	14
Contact us.....	14
Hardware Setup	15
Procedure to access to the port of the Soft starter	16
Electrical Installation	17
Cable Routing Practice	18
Automation Commissioning Only	19
Cybersecurity Generalities	20
Software Setup.....	21
Software Overview	22
Overview	23
IP Parameter Settings.....	24
Ethernet Embedded Configuration	26
Ethernet Embedded Diagnostic	28
Most Common parameters	29
Additional Settings.....	33
Product Restart.....	33
Fast Device Replacement.....	34
Configuring I/O Scanning.....	45
DNS Settings.....	45
SNTP Settings.....	47
SNMP Settings	48
Embedded Webserver	50
Overview.....	50
Connection to the Webserver.....	51
My Dashboard	53
Display - Device.....	54
Setup - My Preference.....	54
Operation	56
Profile.....	57
Functional Profiles Supported by the Altivar Soft Starter	58
Command Channel.....	59
Command Register and Status — [Standard Profile]	61
I/O Profile.....	68
Extended Control Word and Internal State register in [Standard Profile] & [I/O Profile].....	72
Extended Control Word	73
Internal State register.....	74
Starting Sequence	75
Sequence for a Soft starter	76

Sequence for a Soft starter with Mains Contactor Control	79
Monitoring of Communication Channel	81
Network Layer Supported Functions/Protocols	82
TCP and UDP Protocol	84
Modbus TCP Features	86
Modbus TCP Frames	86
Modbus TCP Servers	87
Supported Modbus TCP Functions	87
EtherNet/IP Features	89
EtherNet/IP	89
Cyclical Exchanges (Implicit Exchanges)	89
Messaging (Explicit Exchanges)	90
CIP Object	91
Supported Object Classes	91
Identity Object (01 hex)	92
Message Router Object (02 hex)	95
Assembly Object (04 hex)	96
Connection Manager Object (06 hex)	98
Modbus Object (44 hex)	101
Application Object (70 hex to C7 hex) / Explicit Messaging	102
Port Object (F4 hex)	104
TCP/IP Interface Object (F5 hex)	105
Ethernet Link Object (F6 hex)	108
Diagnostics and Troubleshooting	110
Fieldbus Status LEDs	111
Configuring Communication Error Response	113
Communication troubleshooting	114
Control-Signal Diagnostics	115
Warning Messages	116
Communication error codes	119
ATS490 integration under M580 (in control expert) using	
DTM	122
Introduction	123
Configuration of the M580	124
Soft Starter Configuration with Control Expert	125
Establish the communication between M580 and Soft starter	130
ATS490 integration under Allen Bradley Rockwell using	
EDS	133
Introduction	134
Soft Starter Configuration with SoMove	135
Allen-Bradley Control Logix Configuration	138
Annex	143
Soft Starter State	144
How to interpret and react to a NST state	145
Glossary	146

Safety Information

Important Information

Read these instructions carefully, and look at the equipment to become familiar with the device before trying to install, operate, service, or maintain it. The following special messages may appear throughout this documentation or on the equipment to warn of potential hazards or to call attention to information that clarifies or simplifies a procedure.



The addition of this symbol to a "Danger" or "Warning" safety label indicates that an electrical hazard exists which will result in personal injury if the instructions are not followed.



This is the safety alert symbol. It is used to alert you to potential personal injury hazards. Obey all safety messages that follow this symbol to avoid possible injury or death.

⚠ DANGER
DANGER indicates a hazardous situation which, if not avoided, will result in death or serious injury.

⚠ WARNING
WARNING indicates a hazardous situation which, if not avoided, could result in death or serious injury.

⚠ CAUTION
CAUTION indicates a hazardous situation which, if not avoided, could result in minor or moderate injury.

NOTICE
NOTICE is used to address practices not related to physical injury.

Please Note

Electrical equipment should be installed, operated, serviced, and maintained only by qualified personnel. No responsibility is assumed by Schneider Electric for any consequences arising out of the use of this material.

A qualified person is one who has skills and knowledge related to the construction and operation of electrical equipment and its installation, and has received safety training to recognize and avoid the hazards involved.

Qualification of Personnel

Only appropriately trained persons who are familiar with and understand the contents of this manual and all other pertinent product documentation are authorized to work on and with this product. In addition, these persons must have received safety training to recognize and avoid hazards involved. These persons must have sufficient technical training, knowledge and experience and be able to foresee and detect potential hazards that may be caused by using the product, by changing the settings and by the mechanical, electrical and electronic equipment of the entire system in which the product is used. All persons working on and with the product must be fully familiar with all applicable standards, directives, and accident prevention regulations when performing such work.

Intended Use

This product is intended for industrial use according to this manual.

The product may only be used in compliance with all applicable safety standard and local regulations and directives, the specified requirements and the technical data. The product must be installed outside the hazardous ATEX zone. Prior to using the product, you must perform a risk assessment in view of the planned application. Based on the results, the appropriate safety measures must be implemented. Since the product is used as a component in an entire system, you must ensure the safety of persons by means of the design of this entire system (for example, machine design). Any use other than the use explicitly permitted is prohibited and can result in hazards.

Product related information

Read and understand these instructions before performing any procedure with this soft starter.

DANGER

HAZARD OF ELECTRIC SHOCK, EXPLOSION, OR ARC FLASH

- Only appropriately trained persons who are familiar with and fully understand the contents of the present manual and all other pertinent product documentation and who have received all necessary training to recognize and avoid hazards involved are authorized to work on and with this equipment.
- Installation, adjustment, repair and maintenance must be performed by qualified personnel.
- Verify compliance with all local and national electrical code requirements as well as all other applicable regulations with respect to grounding of all equipment.
- Only use properly rated, electrically insulated tools and measuring equipment.
- Do not touch unshielded components or terminals with voltage present.
- Prior to performing any type of work on the equipment, block the motor shaft to prevent rotation.
- Insulate both ends of unused conductors of the motor cable.

Failure to follow these instructions will result in death or serious injury.

⚡ ⚠ DANGER

HAZARD OF ELECTRIC SHOCK, EXPLOSION, OR ARC FLASH

Before performing work on the equipment:

- Use all required personal protective equipment (PPE).
- Disconnect all power, including external control power that may be present. Take into account that the circuit breaker or main switch does not de-energize all circuits.
- Place a "Do Not Turn On" label on all power switches related to the equipment.
- Lock all power switches in the open position.
- Verify the absence of voltage using a properly rated voltage sensing device.

Before applying voltage to the equipment:

- Verify that the work has been completed and that the entire installation cannot cause hazards.
- If the mains input terminals and the motor output terminals have been grounded and short-circuited, remove the ground and the short circuits on the mains input terminals and the motor output terminals.
- Verify proper grounding of all equipment.
- Verify that all protective equipment such as covers, doors, grids is installed and/or closed.

Failure to follow these instructions will result in death or serious injury.

⚡ ⚠ DANGER

HAZARD OF ELECTRIC SHOCK, EXPLOSION, OR ARC FLASH

- Never operate energized switch with door open.
- Turn off switch before removing or installing fuses or making load side connections.
- Do not use renewable link fuses in fused switches.

Failure to follow these instructions will result in death or serious injury.

Damaged products or accessories may cause electric shock or unanticipated equipment operation.

⚡ ⚠ DANGER

ELECTRIC SHOCK OR UNANTICIPATED EQUIPMENT OPERATION

Do not use damaged products or accessories.

Failure to follow these instructions will result in death or serious injury.

Contact your local Schneider Electric sales office if you detect any damage whatsoever.

This equipment has been designed to operate outside of any hazardous location. Only install this equipment in zones known to be free of a hazardous atmosphere.

⚠ DANGER

POTENTIAL FOR EXPLOSION

Install and use this equipment in non-hazardous locations only.

Failure to follow these instructions will result in death or serious injury.

Your application consists of a whole range of different interrelated mechanical, electrical, and electronic components, the soft starter being just one part of the application. The soft starter by itself is neither intended to nor capable of providing the entire functionality to meet all safety-related requirements that apply to your application. Depending on the application and the corresponding risk assessment to be conducted by you, a whole variety of additional equipment is required such as, but not limited to, external monitoring devices, guards, etc.

As a designer/manufacturer of machines, you must be familiar with and observe all standards that apply to your machine. You must conduct a risk assessment and determine the appropriate Performance Level (PL) and/or Safety Integrity Level (SIL) and design and build your machine in compliance with all applicable standards. In doing so, you must consider the interrelation of all components of the machine. In addition, you must provide instructions for use that enable the user of your machine to perform any type of work on and with the machine such as operation and maintenance in a safe manner.

The present document assumes that you are fully aware of all normative standards and requirements that apply to your application. Since the soft starter cannot provide all safety-related functionality for your entire application, you must ensure that the required Performance Level and/or Safety Integrity Level is reached by installing all necessary additional equipment.

⚠ WARNING

INSUFFICIENT PERFORMANCE LEVEL/SAFETY INTEGRITY LEVEL AND/OR UNINTENDED EQUIPMENT OPERATION

- Conduct a risk assessment according to EN ISO 12100 and all other standards that apply to your application.
- Use redundant components and/or control paths for all critical control functions identified in your risk assessment.
- Verify that the service life of all individual components used in your application is sufficient for the intended service life of your overall application.
- Perform extensive commissioning tests for all potential error situations to verify the effectiveness of the safety-related functions and monitoring functions implemented, for example, but not limited to, speed monitoring by means of encoders, short circuit monitoring for all connected equipment, correct operation of brakes and guards.
- Perform extensive commissioning tests for all potential error situations to verify that the load can be brought to a safe stop under all conditions.

Failure to follow these instructions can result in death, serious injury, or equipment damage.

Product may perform unexpected movements because of incorrect wiring, incorrect settings, incorrect data or other errors.

⚠ WARNING

UNANTICIPATED EQUIPMENT OPERATION

- Carefully install the wiring in accordance with the EMC requirements.
- Do not operate the product with unknown or unsuitable settings or data.
- Perform a comprehensive commissioning test.

Failure to follow these instructions can result in death, serious injury, or equipment damage.

▲ WARNING

LOSS OF CONTROL

- The designer of any control scheme must consider the potential failure modes of control paths and, for critical control functions, provide a means to achieve a safe state during and after a path failure. Examples of critical control functions are emergency stop, overtravel stop, power outage and restart.
- Separate or redundant control paths must be provided for critical control functions.
- System control paths may include communication links. Consideration must be given to the implications of unanticipated transmission delays or failures of the link.
- Observe all accident prevention regulations and local safety guidelines (1).
- Each implementation of the product must be individually and thoroughly tested for proper operation before being placed into service.

Failure to follow these instructions can result in death, serious injury, or equipment damage.

(1) For USA: Additional information, refer to NEMA ICS 1.1 (latest edition), Safety Guidelines for the Application, Installation and Maintenance of Solid State Control.

Machines, controllers, and related equipment are usually integrated into networks. Unauthorized persons and malware may gain access to the machine as well as to other devices on the network/fieldbus of the machine and connected networks via insufficiently secure access to software and networks.

▲ WARNING

UNAUTHORIZED ACCESS TO THE MACHINE VIA SOFTWARE AND NETWORKS

- In your hazard and risk analysis, consider all hazards that result from access to and operation on the network/fieldbus and develop an appropriate cyber security concept.
- Verify that the hardware infrastructure and the software infrastructure into which the machine is integrated as well as all organizational measures and rules covering access to this infrastructure consider the results of the hazard and risk analysis and are implemented according to best practices and standards covering IT security and cyber security (such as: ISO/IEC 27000 series, Common Criteria for Information Technology Security Evaluation, ISO/IEC 15408, IEC 62351, ISA/IEC 62443, NIST Cybersecurity Framework, Information Security Forum - Standard of Good Practice for Information Security, SE recommended Cybersecurity Best Practices*).
- Verify the effectiveness of your IT security and cyber security systems using appropriate, proven methods.

Failure to follow these instructions can result in death, serious injury, or equipment damage.

(*) : SE Recommended Cybersecurity Best Practices can be downloaded on SE.com.

▲ WARNING

LOSS OF CONTROL

Perform a comprehensive commissioning test to verify that communication monitoring properly detects communication interruptions.

Failure to follow these instructions can result in death, serious injury, or equipment damage.

This product meets the EMC requirements according to the standard IEC 60947-4-2. This device has been designed for environment A. Use of this product in a domestic environment (B environment) may cause unwanted radio interference.

▲ WARNING

RADIO INTERFERENCE

- In a domestic environment (B environment), this product may cause radio interference in which case supplementary mitigation measures may be required.

Failure to follow these instructions can result in death, serious injury, or equipment damage.

NOTICE

DESTRUCTION DUE TO INCORRECT MAINS VOLTAGE

Before switching on and configuring the product, verify that it is approved for the mains voltage.

Failure to follow these instructions can result in equipment damage.

About the Book

Validity note

Original instructions and information given in the present document have been written in English (before optional translation).

NOTE: The products listed in the document are not all available at the time of publication of this document online. The data, illustrations and product specifications listed in the guide will be completed and updated as the product availabilities evolve. Updates to the guide will be available for download once products are released onto the market.

This documentation is valid only for ATS490.

The characteristics that are presented in this manual should be the same as those characteristics that appear online. In line with our policy of constant improvement, we may revise content over time to improve clarity and accuracy. If you see a difference between the manual and online information, use the online information as your reference.

The technical characteristics of the devices described in the present document also appear online. To access the information online:

Step	Action
1	Go to the Schneider Electric home page www.se.com .
2	In the Search box type the reference of the product or the name of a product range. <ul style="list-style-type: none"> • Do not include blank spaces in the reference or product range. • To get information on grouping similar modules, use asterisks (*).
3	If you entered a reference, go to the Product Datasheets search results and click on the reference that interests you. If you entered the name of a product range, go to the Product Ranges search results and click on the product range that interests you.
4	If more than one reference appears in the Products search results, click on the reference that interests you.
5	Depending on the size of your screen, you may need to scroll down to see the data sheet.
6	To save or print a data sheet as a .pdf file, click Download XXX product datasheet .

Document Scope

The purpose of this document is to:

- Show how to configure the soft starter to use the Ethernet interface for monitoring and control.
- Provide examples of setup using Ethernet communication.

NOTE: Read and understand this document and all related documents (see below) before installing, operating, or maintaining your soft starter.

Related Documents

Use your tablet or your PC to quickly access detailed and comprehensive information on all our products on www.se.com The Internet site provides the information you need for products and solutions:

- The whole catalog for detailed characteristics and selection guides
- The CAD files to help design your installation, available in over 20 different file formats
- All software and firmware to maintain your installation up to date
- A large quantity of White Papers, Environment documents, Application solutions, Specifications... to gain a better understanding of our electrical systems and equipment or automation
- And finally all the User Guides related to your soft starter, listed below:

Catalog

Title of documentation	Reference number
Catalog: Altivar Soft Starter ATS490	DIA2ED2240603EN (English) DIA2ED2240603FR (French)

Documentations

Title of documentation	Reference number
ATS490 Getting Started	PKR63410 (English), PKR63411 (French) PKR63412 (Spanish), PKR63413 (Italian) PKR63414 (German), PKR63415 (Chinese) PKR63416 (Portuguese), PKR63417 (Turkish)
ATS490 Getting Started Manual Annex for UL	PKR63418 (English)
ATS490 User Manual	PKR52680 (English), PKR52681 (French) PKR52682 (Spanish), PKR52683 (Italian) PKR52684 (German), PKR52685 (Chinese) PKR52686 (Portuguese), PKR52687 (Turkish)
ATS490 Embedded Safety Function Manual	PKR63419 (English)
ATS490 ATEX Manual	BQT74920 (English)
ATS490 Embedded Modbus RTU Manual	PKR63421 (English)
ATS490 EtherNet Manual	PKR63423 (English)
ATS490 PROFIBUS DP Manual (VW3A3607)	PKR63425 (English)
ATS490 CANopen Manual (VW3A3608, VW3A3618, VW3A3628)	PKR63426 (English)
ATS490 Communication Parameter Addresses	PKR63420 (English)
Recommended Cybersecurity Best Practices	CS-Best-Practices-2019–340 (English)

You can download there technical publications and other technical information from our website at www.se.com/en/download.

Videos

Title of documentation	Reference number
Video: Getting Started with ATS490	FAQ000263202 (English)

Software

Title of documentation	Reference number
SoMove: FDT	SoMove FDT (English, French, German, Spanish, Italian, Chinese)
ATS490: DTM	ATS490 DTM Library EN (English – to be installed first) ATS490 DTM Lang FR (French) ATS490 DTM Lang SP (Spanish) ATS490 DTM Lang IT (Italian) ATS490 DTM Lang DE (German) ATS490 DTM Lang CN (Chinese)

Electronic product data sheet

Scan the QR code in front of the soft starter to get the product data sheet.

The diagram illustrates the process of scanning a QR code on a soft starter to access a mobile application interface. The interface displays the following product details:

- Range: Altivar Soft Starter ATS490
- Ref.:
- Desc.:
- SN: 123

The application interface also includes navigation options for:

- Characteristics
- Documentation
- Spare parts

Scanning the QR Code gives you access to :

- Product ID Card : Product range, Reference, short description and a Serial Number (Use the serial number to retrieve the product’s manufacturing date).
- The product characteristics : Main characteristics, environment, packing units, sustainability...
- Documentation : Technical Guidance at Glance (Presentation, Dimensions, Mounting, Wiring, Commissioning...) and Product Documentation (User guide, Instructions sheets, Certificates, How To videos...)
- Spare parts for your product

Terminology

The technical terms, terminology, and the corresponding descriptions in this manual normally use the terms or definitions in the relevant standards.

In the area of soft starters this includes, but is not limited to, terms such as **error**, **error message**, **failure**, **fault**, **fault reset**, **protection**, **safe state**, **safety function**, **warning**, **warning message**, and so on.

Among others, these standards include:



- ISO 13849-1 & 2 Safety of machinery - safety related parts of control systems
- IEC 61158 series: Industrial communication networks - Fieldbus specifications
- IEC 61784 series: Industrial communication networks - Profiles
- IEC 60204-1: Safety of machinery - Electrical equipment of machines – Part 1: General requirements
- IEC 60947–1 Low–Voltage Switchgear and Control Gear – General rules
- IEC 60947–4-2 Semiconductor Motor controllers, Starters and Soft Starters
- IEC 62443: Security for industrial automation and control systems

In addition, the term **zone of operation** is used in conjunction with the description of specific hazards, and is defined as it is for a **hazard zone** or **danger zone** in the EC Machinery Directive (2006/42/EC) and in ISO 12100.

Also see the glossary at the end of this manual.

Structure of the Parameter Table

General Legend

Pictogram	Description
	Power cycle must be performed after setting this parameter.
	Read only parameter, mainly used for monitoring.
	Expert mode required to access this parameter.

Contact us

Select your country on www.se.com/contact.

Schneider Electric Industries SAS

Head Office

35, rue Joseph Monier

92500 Rueil-Malmaison

France

Hardware Setup

What's in This Part

Procedure to access to the port of the Soft starter	16
Electrical Installation.....	17
Cable Routing Practice	18
Automation Commissioning Only.....	19

Procedure to access to the port of the Soft starter

Apply the following instructions to remove the front cover of the soft starter:

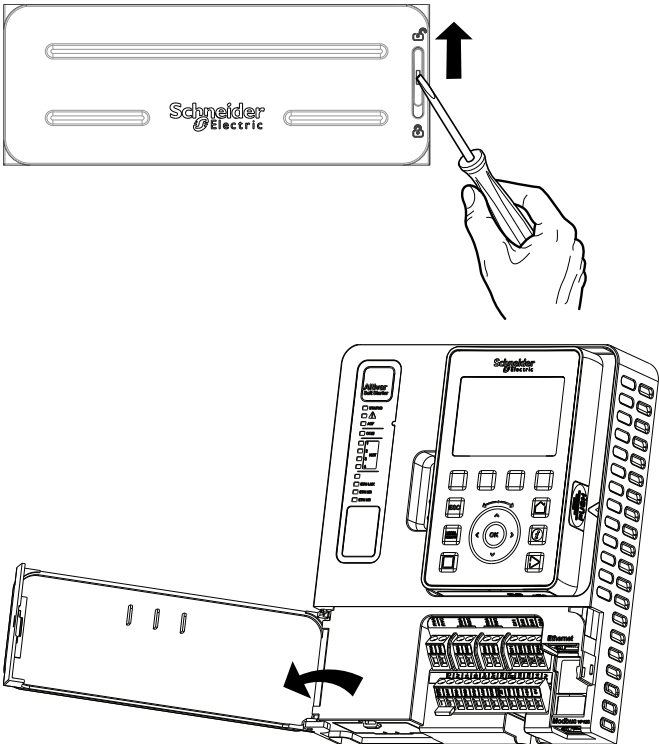
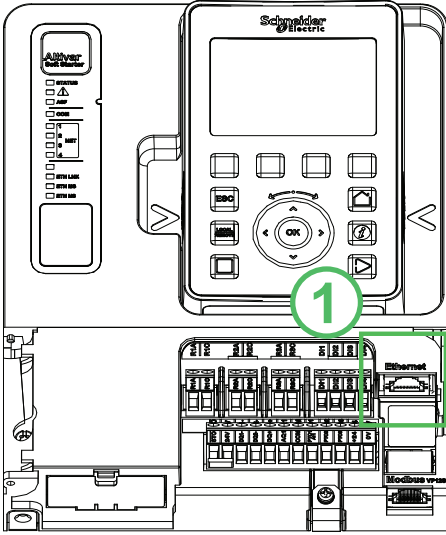
Step	Action	
1	Open the terminal cover	
2	Plug the RJ45 cable to one of the RJ45 socket of the embedded port "Ethernet".	 <p data-bbox="778 1675 1225 1709">1 Embedded Ethernet communication port</p>

Electrical Installation

Pin Layout

The figure shows the RJ45 socket for the Embedded Ethernet connection:

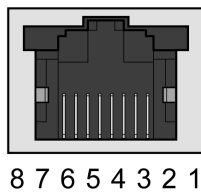

The table provides the pin out details of each RJ45 connector:

Pin	Signal	Meaning
1	Tx+	Ethernet transmit line +
2	Tx-	Ethernet transmit line –
3	Rx+	Ethernet receive line +
4	–	–
5	–	–
6	Rx-	Ethernet receive line –
7	–	–
8	–	–

Cable Specifications

Cable specifications are as follows:

- Ethernet cable must be AWG24 & SF/FTP
- Minimum Cat 5e
- Use equipotential bonding conductors (100 BASE-TX, category 5e or industrial Ethernet fast connect)
- Connector RJ45, no crossover cable
- Shield: both ends grounded
- Twisted-pair cable
- Use pre-assembled cables to reduce the wiring mistakes
- Verify that wiring, cables, and connected interfaces meet the PELV requirements.
- Maximum cable length per segment = 100 m (328 ft)

Cable Routing Practice

Installation Topology

The Ethernet embedded enables one wiring solution:

- Star topology

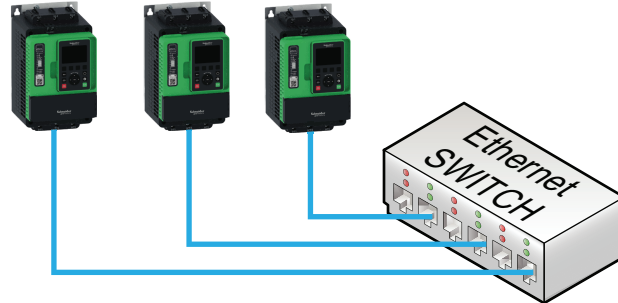

The following figure shows the direct connection between the soft starter and PC.

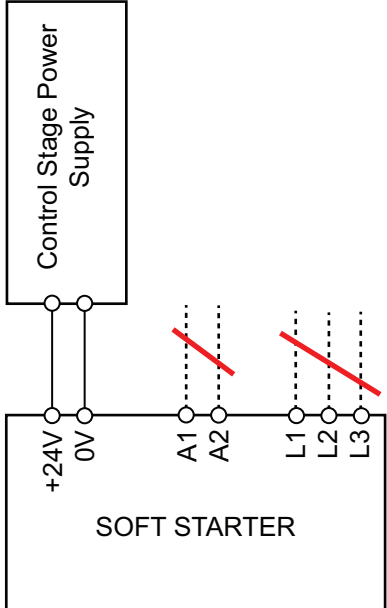

Automation Commissioning Only

Control stage supplied via +24 V of the control board	Use case
 <p>The diagram illustrates the electrical connection for the control stage of a soft starter. A separate 'Control Stage Power Supply' is connected to the '+24V' and '0V' terminals of the 'SOFT STARTER'. The terminals 'A1', 'A2', 'L1', 'L2', and 'L3' are shown with red diagonal lines through them, indicating that they are not connected to any power source in this configuration.</p>	<p>By supplying the product only with +24V, only programming is possible. No motor power supply is possible.</p>

Cybersecurity Generalities

The objective of Cybersecurity is to help provide increased levels of protection for information and physical assets from theft, corruption, misuse, or accidents while maintaining access for their intended users.

No single Cybersecurity approach is adequate. Schneider Electric recommends a defense-in-depth approach. Conceived by the National Security Agency (NSA), this approach layers the network with security features, appliances, and processes.

The basic components of this approach are:

- Risk assessment
- A security plan built on the results of the risk assessment
- A multi-phase training campaign
- Physical separation of the industrial networks from enterprise networks using a demilitarized zone (DMZ) and the use of firewalls and routing to establish other security zones
- System access control
- Device hardening
- Network monitoring and maintenance

This chapter defines the elements that help you configure a system that is less susceptible to cyber-attacks.

Network administrators, system integrators and personnel that commission, maintain or dispose of a device should:

- Apply and maintain the device's security capabilities.
- Review assumptions about protected environments.
- Address potential risks and mitigation strategies.
- Follow recommendations to optimize cybersecurity.

For detailed information on the system defense-in-depth approach, refer to the TVDA: How Can I Reduce Vulnerability to Cyber Attacks (STN V3.0) on se.com.

To submit a Cybersecurity question, report security issues, or get the latest news from Schneider Electric, visit the Schneider Electric website.

▲ WARNING
POTENTIAL COMPROMISE OF SYSTEM AVAILABILITY, INTEGRITY, AND CONFIDENTIALITY
<ul style="list-style-type: none">• Change default password to help prevent unauthorized access to device settings and information.• Disable unused ports/services and default accounts, where possible, to minimize pathways for malicious attacks.• Place networked devices behind multiple layers of cyber defenses (such as firewalls, network segmentation, and network intrusion detection and protection).• Use cybersecurity best practices (for example: least rights, separation of duties) to help prevent unauthorized exposure, loss or modification of data and logs, interruption of services, or unintended operation.
Failure to follow these instructions can result in death, serious injury, or equipment damage.

For more details about cybersecurity, refer to the User Manual.

Software Setup

What's in This Part

Software Overview	22
Overview	23
IP Parameter Settings.....	24
Ethernet Embedded Configuration	26
Ethernet Embedded Diagnostic	28
Most Common parameters.....	29
Additional Settings	33
Embedded Webserver	50

Software Overview

Simplified TCP/IP Model

The table provides the basic overview to the simplified TCP/IP model

Application	Modbus TCP-EtherNet/IP
Transport	TCP / UDP
Network	IP
Link	Ethernet

Modbus TCP-EtherNet/IP Features Overview

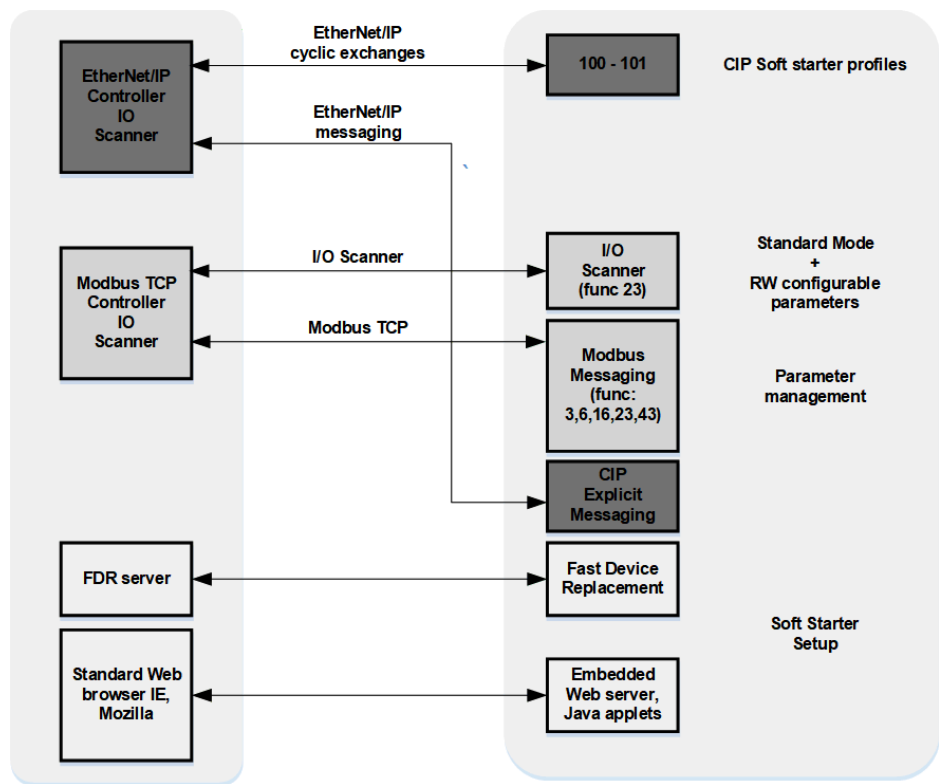

NOTE: When using ModbusTCP, it is advisable to use function codes 16 or 23 to control the soft starter.

Overview

Modbus TCP

The Modbus application layer is standard. Many of the manufacturers are already implementing this protocol. Many have already developed a Modbus TCP/IP connection and numerous products are currently available. With the simplicity of its protocol and the fast Ethernet throughput data rate of 100 Mbit/s, Modbus TCP/IP achieves excellent performance.

EtherNet/IP

EtherNet/IP is a fieldbus based on TCP and UDP. EtherNet/IP extends Ethernet by an advanced industrial protocol (CIP, Common Industrial Protocol) as an application layer for automation applications in this way, Ethernet suites for industrial control. Products from different manufacturers can be networked without the need for special interface adaptation.

TCP/IP and Ethernet Features

The product supports the following functions via:

- Manual IP address assignment
- Automatic IP address assignment via BOOTP or DHCP
- Automatic configuration data via FDR
- Commissioning via DTM-based commissioning software
- Diagnostics and configuration via integrated Web server
- Support of SNTP (Simple Network Time Protocol)
- Support of DNS (Domain Name System)
- Support of IPV6 for DPWS (Devices Profile for Web Services)
- Handling of QoS (Quality of Service)

Web Server

The standard webserver provides access to pages such as:

- My dashboard
- Display
- Diagnostics
- Parameters Layout
- Setup

IP Parameter Settings

Assigning IP Parameters

If not using IPV6 functionalities for DPWS, following parameters shall be configured:

- The soft starter IP address.
- The subnet mask.
- The gateway IP address.

These IP addresses can be entered using the display terminal, the embedded webserver, or the DTM-based PC software.

They can be also provided by:

- A BOOTP server (correspondence between the MAC address and the IP addresses).
- Or a DHCP server (correspondence between device name **[Device Name]** and the IP addresses).

If an IP address other than 0.0.0.0 has been entered manually, assignment using a server is disabled. Regardless of the type of IP address assignment, if the address is modified, then the IP address is effective the next time the soft starter is turned on (control voltage if a separate power supply is being used).

Entering IP Parameters in the Graphic Display Terminal

For the ethernet embedded configuration:

NOTE: To modified **[IP address]**, **[Mask]** and **[Gateway]**:
[IP Mode Ether. Embd] need to be set on **[Fixed]**.

In the **[Communication]** and **[Embd Eth Config]** submenu, enter the following IP addresses:

- **[IP address]**
- **[Mask]**
- **[Gateway]**

If this address is modified, the new IP address entered is displayed.

Configuring BOOTP

The BOOTP service is used to assign IP addresses based on the MAC address. The MAC address consisting of 6 hexadecimal digits (MM-MM-MM-XX-XX-XX) must be entered in the BOOTP server. The MAC address can be access in **[Communication]** → **[Ethernet Emb Diag]**.

In the **[Communication]** and **[Embd Eth Config]** submenu:

- Leave the IP address **[IP address]** at the value **[0.0.0.0]**.
- **[IP Mode Ether. Embd]** need to be set on **[BOOTP]**

Configuring DHCP

The DHCP service is used to assign IP addresses and FDR configuration file path based on the device name **[Device Name]** .

These parameters can be accessed if **[IP Mode Ether. Embd]** is set to **[DHCP]** .

The device name consisting of an alphanumeric string must be entered in both the DHCP server and the soft starter.

In the **[Communication]** and **[Embd Eth Config]** submenu, enter the **[Device Name]**





NOTE: FDR is enabled by default when DHCP, customer could disable FDR from menu **[Device Management]** ➔ **[Emb Eth FDR]** .

Ethernet Embedded Configuration

This menu is to configure the parameters used by the Ethernet Embedded port.

Access path: **[Communication]**.

[Embd Eth Config] menu





HMI label	Setting	
[Device Name] PAN	-	
<p>This parameter is used to set the device name.</p> <p>The FDR (Fast Device Replacement) service is based on identification of the device by a Device Name. In the case of the Altivar soft starter, this is represented by the [Device Name] PAN parameter. Verify that all the network devices have different Device Name.</p>		
[IP Mode Ether. Embd] IM00 	Logic address: FB90 hex = 64400	Type: WORD (Enumeration) Read/write: R/W
<p>IP mode Ethernet Embd</p> <p>This parameter is used to select the IP address assignment method:</p> <ul style="list-style-type: none"> • [Fixed] MANU: Manually set the IP address. • [BOOTP] BOOTP: Automatically gets the IP address from the Bootp or DHCP server using the MAC address. • [DHCP] DHCP: Automatically gets the IP address from the DHCP server using the device name (factory setting). 		
[IP address] IC01, IC02, IC03, IC04 	Logic address IC01: FB91 hex = 64401 Logic address IC02: FB92 hex = 64402 Logic address IC03: FB93 hex = 64403 Logic address IC04: FB94 hex = 64404	Type: INT Read/write: R/W
<p>This parameter is used to set the IP address and can be edited only when the IP mode is set to fixed address.</p>		
[Mask] IM01, IM02, IM03, IM04 	Logic address IM01: FB95 hex = 64405 Logic address IM02: FB96 hex = 64406 Logic address IM03: FB97 hex = 64407 Logic address IM04: FB98 hex = 64408	Type: INT Read/write: R/W
<p>This parameter is used to set the IP subnet mask and can be edited only when IP mode is set to fixed address.</p>		
[Gateway] IG01, IG02, IG03, IG04 	Logic address IG01: FB99 hex = 64409 Logic address IG02: FB9A hex = 64410 Logic address IG03: FB9B hex = 64411 Logic address IG04: FB9C hex = 64412	Type: INT Read/write: R/W
<p>This parameter is used to set the default gateway address and can be edited only IP mode is set to fixed address.</p>		

HMI label	Setting	
[Eth embd : Time-out] TTOB	Logic address: FB9F hex = 64415 Range: 0.1...30.0 s Factory setting: 10.0 s	Type: UINT (Unsigned16) Read/write: R/WS Unit: 0.1 s
Ethernet embedded : time-out		
[Eth Error Response] ETHL	Logic address: 1B6D hex = 7021 CIP Path: 84/01/16 hex = 132/01/22	Type: WORD (Enumeration) Read/write: R/WS Factory setting: [Freewheel Stop]
<p>Ethernet error response This parameter defines the Ethernet embedded error stop mode.</p> <ul style="list-style-type: none"> [Ignore]: No error or warning is triggered. [Freewheel Stop]: Error [Embd Eth Com Interrupt] ETHF is triggered and motor stops in freewheel. [Configured Stop]: Motor stops according to the value set in [Type of stop]. [Deceleration]: Motor stops in deceleration and an error [Embd Eth Com Interrupt] ETHF is triggered at the end of deceleration. [Braking]: Motor stops in dynamic braking stop and an error [Embd Eth Com Interrupt] ETHF is triggered at the end of stop. 		
⚠ WARNING		
<p>LOSS OF CONTROL</p> <p>If this parameter is set to [Ignore] NO, Ethernet communication monitoring is disabled.</p> <ul style="list-style-type: none"> Only use this setting after a thorough risk assessment in compliance with all regulations and standards that apply to the device and to the application. Only use this setting for tests during commissioning. Verify that communication monitoring has been re-enabled before completing the commissioning procedure and performing the final commissioning test. <p>Failure to follow these instructions can result in death, serious injury, or equipment damage.</p>		
[Modbus Address] ADD 	Logic address: 1771 hex = 6001 CIP Path: 7F/01/02 hex = 127/01/02 Range: 0...247 Factory setting: 0	Type: UINT (Unsigned16) Read/write: R/WS Unit: -
Device modbus address		
<p>This parameter sets the Modbus device address. Address 0 is reserved for broadcast.</p>		
[Product restart] RP	—	[Not Assigned] NO
Product restart		
<p>For more information, refer to Product Restart, page 33.</p>		

Ethernet Embedded Diagnostic

Access path: [Communication]

[Ethernet Emb Diag] menu

HMI label	Setting	
[MAC @] 	-	
This parameter displays the MAC address of the Ethernet Embedded port in the format [MM-MM-MM-XX-XX-XX].		
[ETH emb Rx frames] <small>ERXE</small> 	Logic address: FBA0 hex = 64416	Type: UINT (Unsigned32) Read/write: R
Ethernet embedded Rx frames This parameter displays the Ethernet module received Rx frames counter.		
[ETH emb Tx frames] <small>ETXE</small> 	Logic address: FBA2 hex = 64418	Type: UINT (Unsigned32) Read/write: R
Ethernet embedded Tx frames This parameter displays the Ethernet module transmitted frames counter.		
[ETH emb error frames] <small>EERE</small> 	Logic address: FBA4 hex = 64420	Type: UINT (Unsigned32) Read/write: R
Ethernet embedded error frames This parameter displays the Ethernet module error frames counter.		
[Ethernet Rate Data] <small>ARDE</small> 	Logic address: FB9D hex = 64413	Type: WORD (Enumeration) Read/write: R
Ethernet rate data This parameter displays the Ethernet module actual rate. <ul style="list-style-type: none"> • [Auto]: Data rate is auto detected depending on the first data packet received. • [10M. full]: Data rate is set to 10 Mbit/s full. • [10M. half]: Data rate is set to 10 Mbit/s half. • [100M. full]: Data rate is set to 100 Mbit/s full. • [100M. half]: Data rate is set to 100 Mbit/s half. 		

Most Common parameters

For more information about the Communication Parameter Addresses, please refer to the ATS490 Communication Parameter Addresses, page 12.

NOTE: Cannot write cyclically configuration parameters (as the device can remain in **[Freewheel]** *NST*) tagged by R/WS.

Base Monitoring

Code	Settings	
[Motor Current] <i>LCR</i>	Logic address: 0C84 hex = 3204 CIP Path: 71/01/05 hex = 113/01/05	Type: UINT (Unsigned16) Read/write: R Unit: 0.1 A. or 1 A according to the soft starter rating.
Motor current RMS Motor current. Average of the three line currents based on the measurement of the fundamental of the motor line currents.		
[Motor Therm State] <i>THR</i>	Logic address: 259E hex = 9630 CIP Path: 91/01/1F hex = 145/01/31	Type: UINT (Unsigned16) Read/write: R Unit: 1 %
Motor thermal state This parameter monitors the motor thermal state. 100% corresponds to the nominal thermal state at the nominal motor current set to [Motor Nom Current] .		
[Motor Run Time] <i>RTH</i> via communication	Logic address: 0CAC hex = 3244 CIP Path: 71/01/2D hex = 113/01/45	Type: UINT (Unsigned32) Read/write: R Unit: 1 s
Motor run time This parameter monitors how long the motor has been energized.		
[Motor Run Time] <i>RTHH</i> via Display Terminal	Logic address: 0CCA hex = 3274 CIP Path: 71/01/4B hex = 113/01/75	Type: UINT (Unsigned32) Read/write: R/WS Unit: 1 s
Motor run time This parameter monitors how long the motor has been energized.		
[Elc Energy Cons] <i>OCK</i>	Logic address: 299C hex = 10652 CIP Path: 96/01/35 hex = 150/01/53	Type: UINT (Unsigned32) Read/write: R Unit: kWh
Electrical energy consumed by the motor (kWh) This parameter monitors how much energy consumed by the motor in kWh.		

Digital I/O

Code	Settings	
[Logic Inputs States] <i>IL1R</i>	Logic address: 1452 hex = 5202 CIP Path: 7B/01/03 hex = 123/01/03	Type: WORD (BitString16) Read/write: R Unit: -
<p>Logic inputs states This parameter is used to monitor the real value of the [Logic Inputs States].</p> <ul style="list-style-type: none"> • Bit0 : "DI1" Digital inputs real image • Bit1 : "DI2" Digital inputs real image • Bit2 : "DI3" Digital inputs real image • Bit3 : "DI4" Digital inputs real image <p>NOTE: The status of inputs can be read via [Logic Inputs States] <i>IL1R</i> to which a position or level sensor has been wired.</p>		
[Logic Outputs States] <i>OL1R</i>	Logic address: 145C hex = 5212 CIP Path: 7B/01/0D hex = 123/01/13	Type: WORD (BitString16) Read/write: R/W Unit: -
<p>Logic outputs states This parameter is used to write output value or monitor the value depending on if a function is assigned to the corresponding output:</p> <ul style="list-style-type: none"> • Bit0 : "R1" relay real image • Bit1 : "R2" relay real image • Bit2 : "R3" relay real image • Bit8 : "DQ1" Digital outputs real image • Bit9 : "DQ2" Digital outputs real image <p>NOTE: To write an output through communication, no function should be assigned to the corresponding output. Otherwise, writing on the bit linked to the corresponding output has no impact. If an error is triggered, outputs written through communication returns to 0.</p> <p>NOTE: It is only possible to write the output through the active command channel. Consequently, forced outputs can not be disabled on local channel (such as display terminal).</p>		

Analog input

The following diagram explains how the analog input works:

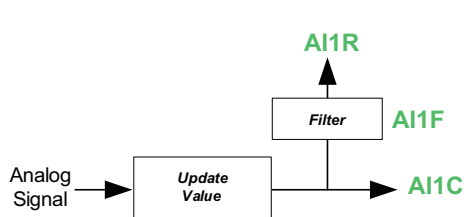

- AI1C [AI1]
- AI1F [AI1 filter]
- AI1R [Analog Input 1 Standardized Value]

Code	Settings	
[AI1] AI1C	Logic address: 147A hex = 5242 CIP Path: 7B/01/2B hex = 123/01/43	Type: INT (Signed16) Read/write: R Unit: -
<p>Physical value AI1 This parameter is used to monitor the real value of the [AI1].</p> <ul style="list-style-type: none"> • [PTC] (0.01kOhm) • [KTY] (1 Ohm) • [PT100]: PT100 (0.1 Ohm) • [PT100 in 3 wires]: PT100 in 3 wires (0.1 Ohm) • [PT1000]: PT1000 (1 Ohm) • [PT1000 in 3 wires]: PT1000 in 3 wires (1 Ohm) 		
 [AI1 filter] AI1F	<p>Setting range: 0...10 s</p> <p>Factory setting: 0 s</p> <p>Logic address: 1164 hex= 4452 CIP Path: 77/01/35 hex = 119/01/53</p>	Type: UINT (Signed16) Read/write: R/W Unit: seconds
<p>AI1 filter This parameter sets the cutoff time of the low filter for PTC1/AI1. The low pass filter aims to suppress electrical noise and avoid interference issue in the input signal.</p>		
[Analog Input 1 Standardized Value] AI1R	Logic address: 1470 hex= 5232 CIP Path: 7B/01/21 hex = 123/01/33	Type: INT (Signed16) Read/write: R Unit: -
<p>Analog input 1 standardized value Real image of AI1 consumed by functions.</p>		

Analog outputs

The analog outputs can be controlled via the network. Simply write these parameters. The outputs to be controlled must not be assigned to a function, otherwise the write operation has no effect.

NOTE: To write an output through communication, no function should be assigned to the corresponding output. Otherwise, writing on the register linked to the corresponding output has no impact. If an error is triggered, outputs written through communication returns to 0.

NOTE: It is only possible to write the output through the active command channel. Consequently, forced outputs can not be disabled on local channel (such as display terminal).

The following diagram explains how the analog output works:

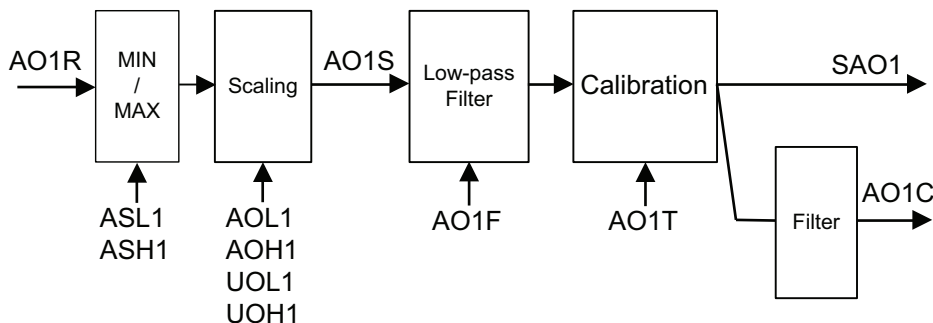

- AO1R [Analog Output 1 Standardized Value]
- ASL1 [Scaling AQ1 Min]
- ASH1 [Scaling AQ1 Max]
- AOL1 [AQ1 min output]
- AOH1 [AQ1 max output]
- UOL1 [AQ1 min Output]
- UOH1 [AQ1 max Output]
- AO1S [AQ1 Scaling]
- AO1F [AQ1 Filter]
- AO1T [AQ1 Type] : is too select between mA and V.
- SAO1 [AO1 Physical Value Without Filter]
- AO1C [AQ1]

Code	Settings	
[Analog Output 1 Standardized Value] AO1R	Logic address: 148D hex = 5261 CIP Path: 7B/01/3E hex = 123/01/62	Type: INT (Signed16) Read/write: R/W Unit: -
<p>Analog output 1 standardized value This parameter is used to read and write a value on AO1. Real image of AO1 consumed by functions.</p>		
[AQ1] AO1C	Logic address: 1497 hex = 5271 CIP Path: 7B/01/48 hex = 123/01/72	Type: INT (Signed16) Read/write: R/W Unit: -
<p>AQ1 physical value This parameter is used to read and write a value, readable on display terminal.</p>		

Additional Settings

What's in This Chapter

Product Restart 33
 Fast Device Replacement 34
 Configuring I/O Scanning 45
 DNS Settings 45
 SNTP Settings 47
 SNMP Settings 48

Product Restart

HMI label	Setting	
[Product restart] ^{RP}	Logic address: 1BD8 hex = 7128 Factory setting: [No]	Type: WORD (Enumeration) Read/write: R/WS
<p>Product restart</p> <p>This parameter is automatically set to [No] after restart.</p> <ul style="list-style-type: none"> [No]: No restart [Yes] : Restart the soft starter. After select [Yes], this safety message is displayed: The Restart function performs a Fault Reset and then restarts the device. During this Restart procedure, the device goes through the same steps as if it had been switched off and on again. Depending on the wiring and the configuration of the device, this may result in immediate and unanticipated operation. <div style="border: 1px solid black; padding: 10px; text-align: center;"> <p>⚠ WARNING</p> <p>UNANTICIPATED EQUIPMENT OPERATION</p> <p>The Restart function performs a Fault Reset and restarts the device.</p> <ul style="list-style-type: none"> Verify that activating this function does not result in unsafe conditions. <p>Failure to follow these instructions can result in death, serious injury, or equipment damage.</p> </div> <p>Confirm the message and the soft starter will restart.</p>		

Fast Device Replacement

FDR Service

The FDR (Fast Device Replacement) service is used to simplify the maintenance of soft starters connected to an Ethernet network. In the event of a soft starter not working correctly, this service automatically reconfigures its replacement.

The new soft starter (FDR client) retrieves:

- Its IP addresses and the FDR file path from a DHCP server
- The FDR file from an FTP server if the soft starter is not configured in local configuration

In practice, the DHCP server and the FTP server are the same device (PAC M580, M340 PLC, M251MESE or dedicated PCs).

The FDR file contains:

- The Ethernet parameters (configuration of I/O scanning, FDR, and so on)
- The soft starter parameters (soft starter, functions, application, and so on)

The FDR service is based on identification of the device by a **Device Name**. In the case of the soft starter, this is represented by the **[Device Name]** PAN parameter.

The configuration of the FDR service is accessible via embedded webserver or DTM-based software or Graphic Display Terminal.

NOTE: Check that all the network devices have different **Device Name**.

The FDR server controls duplication of **Device Name** (it does not assign an IP address that has already been assigned and is active).

If the same IP address is supplied on 2 devices, a **[External Error]** EPF1 will be triggered.

If the FDR service has been enabled, the Ethernet adapter attempts to restore its IP addresses on each power-up. Each time the procedure has detected error, the Ethernet adapter reiterates its FDR requests (DHCP).

After assigning the Ethernet adapter IP addresses, if the configuration is not downloaded successfully, the Ethernet embedded triggers a **[FDR 1 Error]** FDR1.

NOTE: FDR does not handle the cyber configuration (SECP file).

FDR Settings

Access

The parameters are accessible via the webserver or the DTM-based PC software

FDR Configuration via webserver

The **FDR** tab can be found under **Setup** tab then under **Fieldbus → TCP/IP**.

The following figure shows FDR settings via webserver:

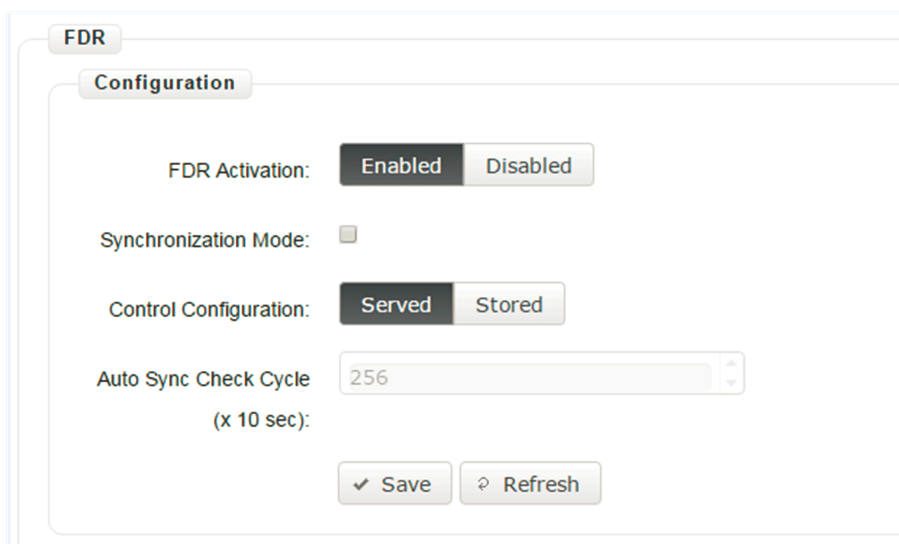

The table presents the **FDR Configuration** settings:

Parameter	Description	Settings
FDR Activation	This parameter is used to enable or disable the FDR service NOTE: Enable FDR only if the IP assignment mode selected is DHCP.	Enabled: FDR service enabled Disabled: FDR service disabled. Factory setting: Enabled
Control Configuration	This parameter is used to select the server or local configuration.	Served: Transfers the configuration file from server to sot starter at power-up. Stored: uses the configuration stored in the sot starter at power-up. Factory setting: served
Automatic Syncho Cycle (x 10 Sec)	Allows you to select the interval for periodic synchronization of the soft starter with the FDR server. NOTE: Configure automatic Syncho cycle only if Synchronization mode check box is selected.	100...655350 sec Factory setting: 100 sec

FDR Configuration via SoMove

The **FDR** tab can be found under **Parameters list** tab then under **Communication → Port -Modbus TCP/EthernetIP**.

Fast Device Replacement (FDR)

Device FDR function start-up control

Device FDR function	ENABLE
<p>i A transfer will be initiated at device power-up, after the device IP address is served by the DHCP server.</p>	
Configuration transfer direction	Served
<p>i Configuration Served (default): the device gets its configuration from the FDR server Configuration Stored: the device uses its local configuration</p>	

Device FDR scheduling

Automatic Synchronization	<input type="checkbox"/>	Automatic Synchro Cycle (10 x Sec)	256
<p>i Automatic synchronization (default): the device sends cyclically its configuration to the server</p>			

Manual FDR configuration transfer

Transfer Configuration	Store: Device to Server	Serve: Server to Device
------------------------	-------------------------	-------------------------

Troubleshooting

To transfer the initial device configuration in the FDR server, the following sequence should be followed:

- 1- Prepare the local device configuration
- 2- Transfer configuration to FDR server
 - Set Device FDR Function= Enabled, then press Apply
 - Restart The Device
 - Manually transfer the configuration from Device to Server (Store to Server)

i In case of FDRx^(*) error, check the FDR error sub-code for details (Server not active, Missing device configuration in the server...)

i Store to Server action is possible ,even if FDRx^(*) error is active.

i After the FDR restore, click Refresh button to synchronize dtm with device

^(*)1 for an Embedded communication, 2 for an option board

[Emb Eth FDR] FDR

This menu is accessible via: **[Device Management]** DMT

These parameters can be accessed if **[IP Mode Ether. Embd]** IM00 is set to **[DHCP]** DHCP.

The FDR can be set using these parameters:

HMI label	Setting	
[Enable FDR] FDV0	Logic address: FBB3 hex = 64435 Factory setting: [Yes]	Type: WORD (Enumeration) Read/write: R/WS
<p>Enable FDR function This parameter is used to enable or disable the FDR service.</p> <ul style="list-style-type: none"> [No]: FDR service disabled. [Yes]: FDR service enabled. 		
[FDR Action] FDA0	Logic address: FBB2 hex = 64434	Type: WORD (Enumeration) Read/write: R/W
<p>FDR action This parameter is used to select the FDR action that needs to be performed.</p> <ul style="list-style-type: none"> [NOT ACTIVE]: No FDR action. [SAVE]: FDR save command. [REST]: FDR restore command. 		
[FDR Operating State] FDS0	Logic address: FBB1 hex = 64433	Type: WORD (Enumeration) Read/write: R
<p>FDR operating state This parameter is used to display the FDR operating state.</p> <ul style="list-style-type: none"> [Initialization] INIT: Initialization. [Not Active] IDLE: Function not active. [Operational] OPE: Operational. [Ready] RDY: Ready. [IP Configuration] IPC: IP configuration. [Not Configured] UNCF: Function not configured. [Reading Configuration] GET: Download the current configuration. [Writing Configuration] SET: Save the current configuration. [Applying Configuration] APP: Applying the configuration to the soft starter. 		

HMI label	Setting	
[FDR Error Status] <i>FDR0</i>	Logic address: FBB0 hex = 64432	Type: WORD (Enumeration) Read/write: R
<p>FDR error status This parameter is used to display the FDR error status.</p> <ul style="list-style-type: none"> • [No Error] <i>NO</i>: No error. • [Server Timeout] <i>TOUT</i>: Server timeout. • [Server No File] <i>SNF</i>: No file on server. • [Server Corrupt File] <i>CRPT</i>: Corrupted file on server. • [Server Empty File] <i>EPTY</i>: Empty file on server. • [Device Invalid File] <i>HINV</i>: Invalid file on soft starter. • [CRC Error] <i>CRC</i>: CRC error. • [Version Incompatibility] <i>VRM</i>: Version incompatibility between soft starter and file. • [Device No File] <i>HNF</i>: No file on soft starter. • [Server Reading Size] <i>SIZE</i>: File size reading error on server. • [Device Opening File] <i>OPEN</i>: Soft starter cannot open the file. • [Device Reading File] <i>READ</i>: Soft starter cannot read the file. • [Incompatibility] <i>SCNT</i>: File incompatibility. • [Device Invalid Name] <i>NINV</i>: Soft starter name is invalid. • [Server Incorrect File Size] <i>FSIZ</i>: Incorrect file size on server. • [Device Writing File] <i>HWF</i>: Soft starter cannot write the file. • [Server Writing File] <i>SWF</i>: Server cannot write the file. <p>Refer to [FDR 1 Error] <i>FDR1</i>, page 121 for more information.</p>		

Startup Detailed Behavior

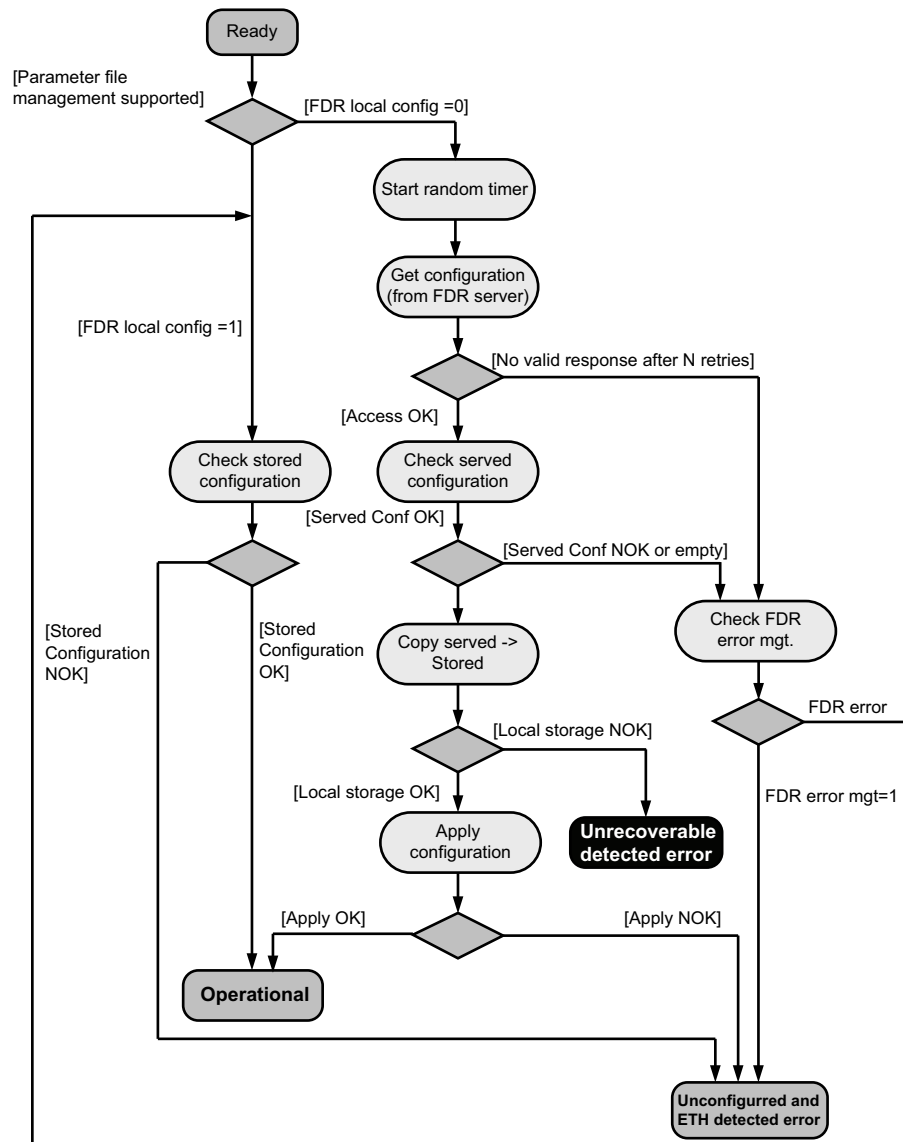

FDR Operation Behavior

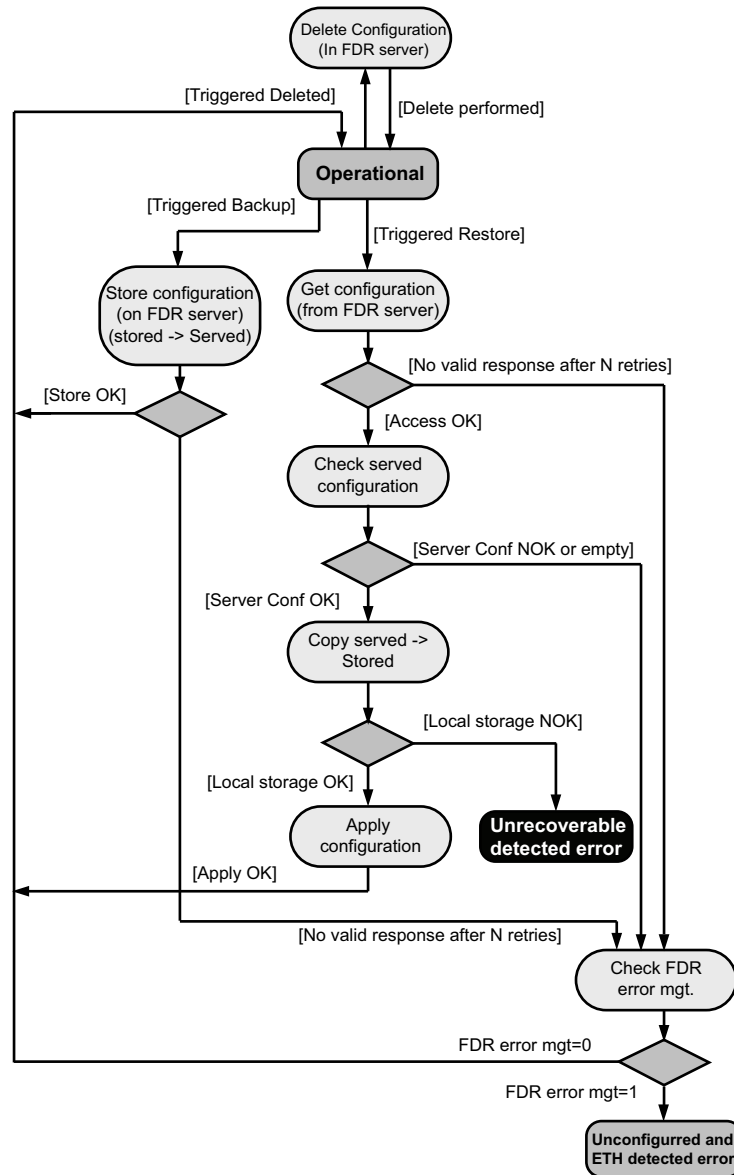

Local Configuration

Presentation

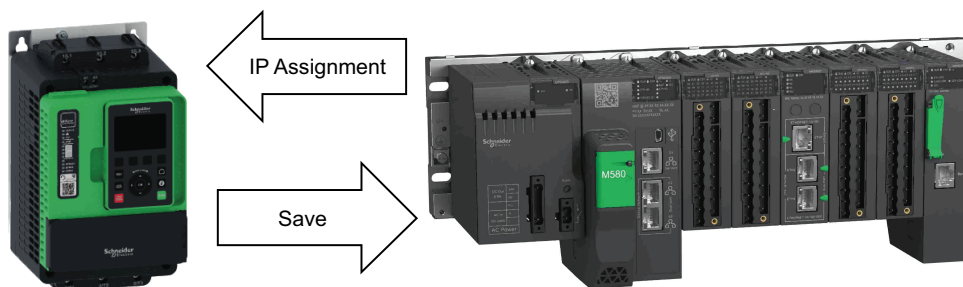

IP Assignment Save

If the soft starter parameter configuration is local, the FDR server only assigns the following IP addresses:

- IP address,
- Subnet mask,
- Gateway IP address.

On connection to the network, the soft starter automatically saves its parameters in the FDR server.

Soft Starter Connection Procedure

Step	Action	Description
1	Configure the FDR server	See the PLC manual or the section on software setup using Ecostruxure Control Expert.
2	Configure the soft starter	This menu is accessible via [Communication] COM, [Embd Eth Config] ETE submenu. <ul style="list-style-type: none"> • Configure [IP Mode Ether. Embd] IM00 = [DHCP] DHCP • Enable the FDR service via webserver or DTM-based software or Graphic Display Terminal. • Select local soft starter configuration with webserver or DTM-based software. • Enter the device name, DEVICE NAME, in the [Communication] COM, [Embd Eth Config] ETE submenu.
3	Turn off the soft starter	Turn off the soft starter and then back on again (control voltage supply if a separate power supply is being used), otherwise the device name is not taken into account
4	Connect the soft starter to the network	Connect the soft starter and the FDR server (PLC) to the Ethernet network

Downloaded Configuration

Presentation

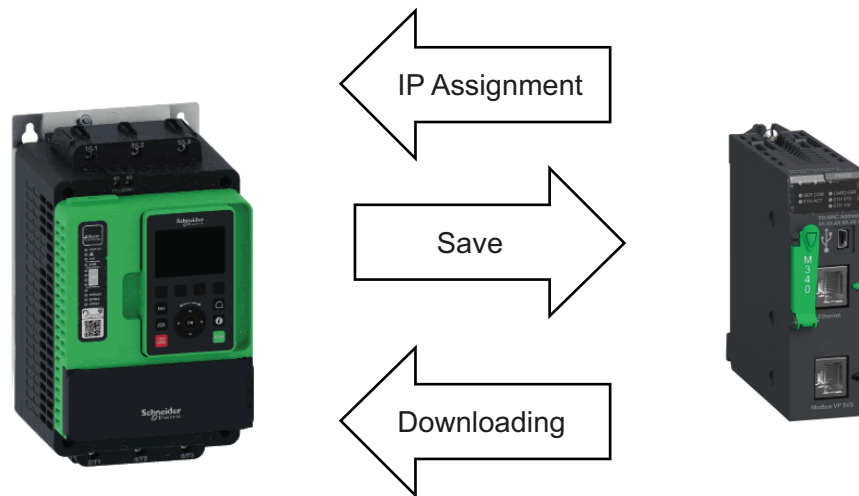

IP Assignment Save

If the soft starter parameter configuration has been downloaded, the FDR server assigns the following addresses:

- IP address,
- Subnet mask,
- Gateway IP address,
- FDR server IP address.

Periodic Saving

Periodic saving of the soft starter configuration can be configured on the FDR server in either local configuration or downloaded configuration mode

Using the commissioning tools:

- Set FDR synchronization to automatic mode
- Set the synchronization cycle time

NOTE: Saving too often overburden the fieldbus and adversely affects its performance (factory setting: 2.560 s.).

Limitations

The FDR service is able to store the current configuration of the soft starter, but does not provide the possibility to store multi-parameters configurations.

Soft starter Parameters (Configuration)

In the procedure described below, the configuration file is transferred to the FDR server, via the Ethernet network, using a manual save command.

Step	Action	Description
1	Configure the soft starter	<p>This menu is accessible via [Communication] COM, [Embd Eth Config] ETE submenu.</p> <ul style="list-style-type: none"> Leave the IP address [IP address] IC01, IC02, IC03, IC04 at the value [0.0.0.0]. <p>Using the embedded commissioning tools:</p> <ul style="list-style-type: none"> Set FDR synchronization to manual mode. Before the first connection, select local soft starter configuration. The soft starter needs first to push the configuration to the server. Enter the device name, DEVICE NAME, in the [Communication] COM, [Embd Eth Config] ETE submenu.
2	Turn off the soft starter	Turn off the soft starter and then back on again (control voltage if a separate power supply is being used), otherwise the device name is not taken into account
3	Connect the soft starter to the fieldbus	Connect the soft starter and the FDR server (PLC) to the Ethernet fieldbus.
4	Configure the FDR server (see the PLC manual)	<p>The server downloads the IP addresses to the Ethernet adapter. Check that the operation has proceeded correctly: you can also check, in the [Communication] COM, [Embd Eth Config] ETE submenu.</p> <p>Whether the [IP address] IC01, IC02, IC03, IC04, [Mask] IM01, IM02, IM03, IM04 and [Gateway] IG01, IG02, IG03, IG04 parameters have values other than [0.0.0.0].</p>
5	Supply the FDR server with the configuration file	<p>Using the commissioning tools:</p> <ul style="list-style-type: none"> Specify that the soft starter configuration is downloaded from the FDR server on each power-up Send a save command to the FDR server.
6	Check that the system is operational	If the save operation has not been successful, the adapter detects a communication error which, in factory settings mode, triggers a [FDR 1 Error] FDR1 .

Replacing a soft starter

For replacing a soft starter, it is necessary to follow the procedure below:

Step	Action	Action
1	Configure the soft starter	<p>This menu is accessible via [Communication] COM, [Embd Eth Config] ETE submenu.</p> <ul style="list-style-type: none"> Leave the IP address [IP address] IC01, IC02, IC03, IC04 at the value [0.0.0.0]. <p>Using the commissioning tools:</p> <ul style="list-style-type: none"> Set FDR synchronization to manual mode. Before the first connection, select served soft starter configuration. The soft starter needs first to transfer the configuration from the server. Enter the device name, DEVICE NAME, in the [Communication] COM, [Embd Eth Config] ETE submenu.
2	Turn off the soft starter	Turn off the soft starter and then back on again (control voltage if a separate power supply is being used), otherwise the device name is not taken into account
3	Connect the soft starter to the fieldbus	Connect the soft starter and the FDR server (PLC) to the Ethernet fieldbus
4	Check that the soft starter is operational	<p>Check that the operation has proceeded correctly.</p> <p>If downloading has not been possible after a period of 2 min following assignment of the IP addresses, the adapter detects a communication error which, in factory settings mode, triggers an [FDR 1 Error] FDR1.</p>

Configuring I/O Scanning

Description

In Communication, Port - Modbus TCP/EtherNetIP, Protocol & Device Profiles.

The soft starter I/O scanning service can be enabled or disabled with the DTM-based PC software.

It is not possible to modify the assignment of the I/O scanning periodic variables using the display terminal. To configure I/O scanning, use the DTM-based PC software.

Protocols & Device Profiles

Protocol

EtherNet Protocol : Modbus TCP EtherNet / IP

EtherNet / IP

IO Connection Profile: 100/101 Generic

Holdup Time: 10.0 sec

Fallback Mode: Freeheel stop

The modification of the IO Profile will be taken into account only if the IO scanner is stopped (use the IO scanner control bits in the MS80 or BME NOC Device DDT, or use a PLC STOP if the IO scanner is the CPU).

Device I/O Profile

Inputs (Device to Controller)				Outputs (Controller to Device)			
Channel	Code	Description	Logical address	Channel	Code	Description	Logical address
1	ETA	Status Register	3201	1	CMD	Command register	8501
2	LCR	Motor current	3204	2	OL1R	Logic outputs states	5212
3	THR	Motor thermal state	9630	3	AO1C	AQ1 physical value	5271
4	ERRD	CiA402 error code	8606	4	RPR	Counter reset	3120
5	RTH	Motor run time	3244	5			
6	OCK	Electrical energy consumed by the motor (kWh)	10652	6			
7	IL1R	Logic inputs states	5202	7			
8	CCC	Active command channel	8442	8			
9				9			

DNS Settings

Description

The Domain Name System (DNS) is a distributed naming system for devices connected to the network.

It translates domain names to IP addresses for locating the devices easily on the network.

DNS Configuration

The DNS configuration can be done using the DTM-based PC software.

The following figure shows the DNS configuration window:

DNS Configuration window by the Web Server

DNS Configuration window by the DTM

The table presents the **DNS Configuration** settings:

Item	Description
1	Obtain DNS Server address automatically: When checked, the function is enabled and allows getting automatically the IP address from the DNS server.
2	Preferred DNS server: Enter the IP address of the preferred DNS server.
3	Alternate DNS server: Enter the IP address of the alternate DNS server. NOTE: The alternate IP address is used only if the first server is unavailable.

NOTE: The changes must be applied to the module configuration by clicking

the  button.

SNTP Settings

Description

The Simple Network Time Protocol (SNTP) is networking protocol for clock synchronization of devices connected to the network.

SNTP Configuration

The SNTP configuration can be done using the DTM-based PC software.

The following figure shows the SNTP Configuration window:

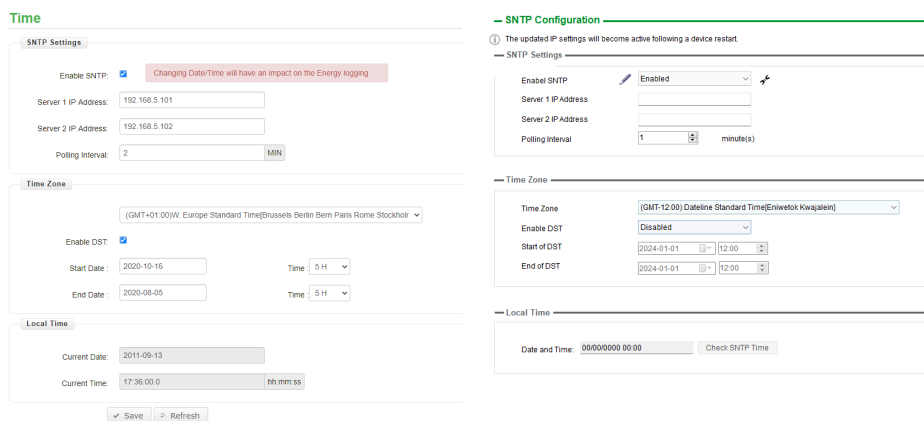

SNTP Configuration window by the Web Server SNTP Configuration window by the DTM

The **SNTP Configuration** window is divided in 2 zones:

- **SNTP Settings**
- **Local Time**

The table presents the **SNTP settings**:

Item	Description
1	Enabled: Enables SNTP service. Disabled: Disables SNTP service.
2	Server 1 IP Address: Enter the IP address of the first preferred SNTP server.
3	Server 2 IP Address: Enter the IP address of the second preferred SNTP server. NOTE: This IP address is used for SNTP only if the first server is unavailable.
4	Polling Interval: Allows you to select the scanning interval for checking the time change.

The table presents the **Local Time** settings:

Item	Description
a	Current Date: Allows you to enter the current date
b	Current Time: Allows you to select the current time

NOTE: The changes must be applied to the module configuration by clicking

the  button.

SNMP Settings

Description

Simple Network Management Protocol (SNMP) is an internet-standard protocol used to manage devices on IP networks.

It is used for collecting and organizing information about the devices on the network.

SNMP Configuration

The SNMP configuration can be done using the DTM-based PC software.

The following figure shows the SNTP Configuration window:

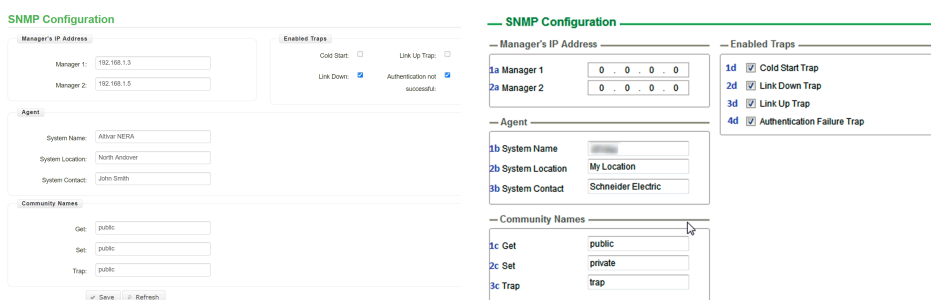

SNMP Configuration window by the Web Server

SNMP Configuration window by the DTM

The **SNMP Configuration** window is divided in 4 zones:

- **Manager's IP Address**
- **Agent**
- **Community Names**
- **Enabled Traps**

Manager's IP Address

SNMP manager is a central system used for monitoring and controlling the SNMP agents.

The table presents **Manager's IP Address** settings:

Item	Description
1a	Manager 1: SNMP manager is a central system, which is used for monitoring and controlling the SNMP agents.
2a	Manager 2: Enter the IP address of SNMP manager 2.

Agents

Agents are the devices which are connected to the network. The SNMP manager monitors these devices.

The table presents the **Agents** settings:

Item	Description
1b	System Name: Enter the system name used by the soft starter.
2b	System Location: Enter the system location of the soft starter.
3b	System Contact: Contact point to get the information about the system. Enter the system contact of the soft starter.

Community Names

Community names are used to identify the commands that can be performed by an SNMP manager on a device.

The table presents the **Community Names** settings:

Item	Description
1c	Get: Requests send from manager to agent to retrieve data.
2c	Set: Requests send from manager to agent to change data.
3c	Trap: Requests send from manager to agent to find the available data.

Enabled Traps

Traps are used to inform the SNMP manager of specific events occurring on device.

The table presents the **Enabled Traps** settings:

Item	Description
1d	Cold Start: The agent reinitialized its configuration tables.
2d	Link Down Trap: A network interface card (NIC) on agent reinitializes.
3d	Link Up Trap: A network interface card (NIC) on agent stops responding.
4d	Authentication Failure Trap: SNMP agent gets a request from an unrecognized community name.

Embedded Webserver

What's in This Chapter

Overview	50
Connection to the Webserver	51
My Dashboard	53
Display - Device	54
Setup - My Preference	54

Overview

Webserver

The Ethernet adapter provides an integrated Web server which allows several functions like: display, parameter settings, and diagnostics. This chapter describes the services provided by this webserver.

Connection to the Webservice

Access

The webservice can be accessed from standard browsers.

First connect the computer to the soft starter by typing the drive IP address in the browser.



- If CyberSecurity level is Advanced
First enter a **User Name** and a **Password**.
- If CyberSecurity level is Minimum, then no authentication is required to access to the web

Once connected, the webservice home page is displayed.

Using IPV6 network discovery service, there is no need to set IP parameters. The soft starter appears automatically in the network explorer of the PC while physically connected to the device.

The soft starter is identified as ATS••••••••-XXXX where XXXX is the two last bytes of the MAC address.

NOTE: Microsoft Windows can block this feature, check on windows options network of your computer.

Right-click and select **Device web page** to open the webservice.

NOTE: If the soft starter was first connected to the commissioning tools via the embedded ethernet, and this user's authentication password has been changed, the default password is no longer applicable. The new password is set. This new password is not displayed on the Graphic Display Terminal.

The webservice can be deactivated via cybersecurity configuration, refer to the user manual.

Web Server Site Map

The descriptions of the Web server pages are shown in the following table:

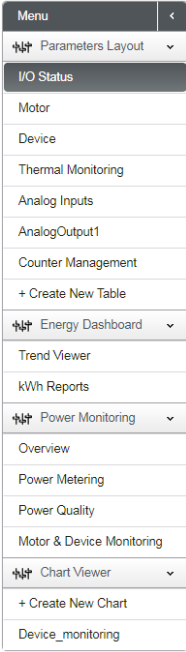
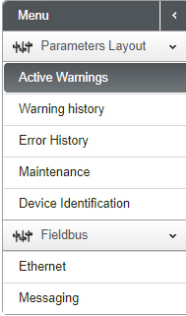
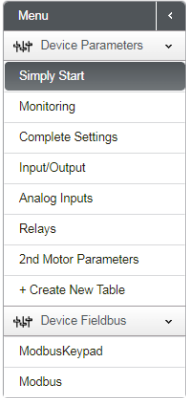
Page	Menu	Description
My Dashboard	—	This page can be customized, adding or removing Widgets that are designed for a quick overview of the soft starter data.
Display 	Parameters Layout	Soft starter parameters are displayed in data tables. Customized tables can be created.
	Energy Dashboard	Trends show information about the energy consumption of the soft starter.
	Power Monitoring	This page will provide information about : <ul style="list-style-type: none"> • Energy, • Power metering and quality, • Motor and device monitoring.
	Chart Viewer	Soft starter parameters are displayed in charts. Customized charts can be created.
Diagnostics 	Parameters Layout	Soft starter diagnostics are displayed.
	Fieldbus	Communication diagnostics are displayed.
Parameters Layout 	Device Parameters	Soft starters settings can be modified.
	Device Fieldbus	Communication settings can be modified.

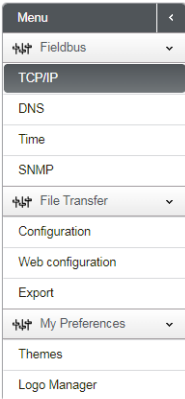
Page	Menu	Description
Setup 	Fieldbus	Soft starter Ethernet settings can be modified.
	File Transfer	Soft starter configuration, webservice configuration can be export / import and Logs can be exported.
	My Preferences	Webserver appearance can be handled.

My Dashboard

Overview

The following table provides the procedure to add the widget to this page:

Step	Action
1	Click the add a widget button.
2	Drag a widget to the desired location.

The following figure shows the widgets that can be added. Various widgets of a same category are available.

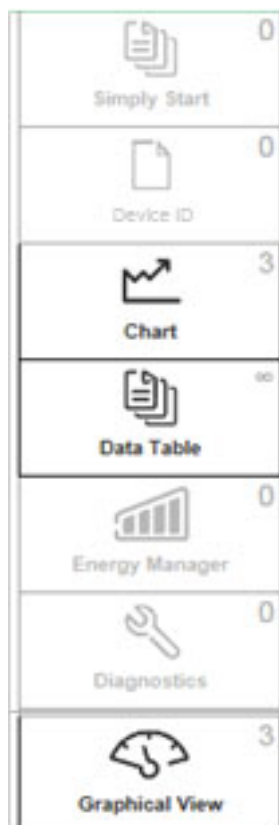

Display - Device

Data Table

The following table provides the procedure to create data tables of soft starter parameters.





Step	Action
1	Type the name of the table. Spaces are not allowed in this field.
2	Select a parameter by clicking the top of the parameter or typing the code and clicking the  button. To delete a parameter while creating the table click the parameter.
3	Click the Add Table button. To remove a table click the  button, only visible when the table is selected.

Chart Viewer

The following table provides the procedure to create a chart viewer.

Step	Action
1	Type the name of the chart. Spaces are not allowed in this field.
2	Select the plot frequency.
3	Select the plot frequency unit.
4	Select the number of plot points.
5	Select a parameter by clicking the top of the parameter or typing the code and clicking the  button. To delete a parameter while creating the chart click the parameter. Maximum of five parameters can be selected.
6	Click the Create Chart button. To remove a chart click the  button, only visible when chart is selected.

Setup - My Preference

Logo Manager

In this menu, the logo of the Web server can be changed.



The following table provides the procedure for select a new logo:

Step	Action
1	Click the  button.
2	Upload an image from local computer.
3	To apply a new logo, create a new Theme.

Themes Manager

In this menu, the aspect of the Web server can be changed. Predefined themes are available, which can be customized.

The following table provides the procedure for creating new themes:

Step	Action
1	Click the  button.
2	Type the name of the theme. Spaces are not allowed in this field.
3	Type the description of the theme.
4	Upload a theme by clicking the  button.
5	Type name of the website.
6	Select a logo.
7	Click the Save button.

Operation

What's in This Part

Profile.....	57
Functional Profiles Supported by the Altivar Soft Starter	58
Command Channel	59
Command Register and Status — [Standard Profile]	61
I/O Profile	68
Extended Control Word and Internal State register in [Standard Profile] & [I/O Profile].....	72
Starting Sequence.....	75
Monitoring of Communication Channel.....	81
Network Layer Supported Functions/Protocols	82
TCP and UDP Protocol	84
Modbus TCP Features.....	86
EtherNet/IP Features.....	89
CIP Object.....	91

Profile

There are 3 types of profile:

- Communication profiles
- Functional profiles
- Application profiles

Communication Profile

A communication profile describes the characteristics of a bus or network:

- Cables
- Connectors
- Electrical characteristics
- Access protocol
- Addressing system
- Periodic exchange service
- Messaging service
- ...

A communication profile is unique to a type of fieldbus (such as Modbus, PROFIBUS DP, and so on) and is used by different types of devices.

Functional Profile

A functional profile describes the behavior of a type of device:

- Functions
- Parameters (such as name, format, unit, type, and so on.)
- Periodic I/O variables
- State chart
- ...

Application Profile

Application profile defines the services to be provided by the devices on a machine.

Interchangeability

The aim of communication and functional profiles is to achieve interchangeability of the devices connected via the fieldbus.

Functional Profiles Supported by the Altivar Soft Starter

Two functional profiles are supported by the Altivar Soft Starter:

- Standard Profile via **[Control Mode]** set to **[Standard Profile]**.
- I/O Profile via **[Control Mode]** set to **[I/O profile]**.

Standard Profile

The Standard Profile supported by the Altivar Soft Starter is based on the CiA402, which has been adapted to the characteristics of the Altivar Soft Starter and therefore to all communication ports.

5 bits of the control word (bits 11...15) can be assigned to a function.

NOTE:

- Altivar Soft Starter starts up following a command sequence
- After switching on and when an operating mode is started, Altivar Soft Starter goes through several operating states

I/O Profile

This profile supported by all channel commands. It mirrors the use of the terminal by allowing to use 1 bit of command register to activate a function.

- I/O profile can also be used when controlling via a fieldbus.
- N bits of **Command register** can be assigned to a specific function.
 - N from 1 to 15 if 2 wires control
 - N from 2 to 15 if 3 wires control.
- **Status Register** is standardized as **[Standard Profile]**.
- According to command sent via **Command register** to operating states diagram, a **Status Register** is updated.

Configuration of the Soft starter command channel according to the selected Profile

This section describes how to configure the command channel settings of the soft starter.

In order to switch in **[Standard Profile]**, **[Expert]** level access should be configured.

The active command channel is then defined by CD1 or CD2 according to **[Command Switching]** (expected if forced local feature is used).

NOTE: for more information about **[Forced Local Assign]** and **[HMI L/R cmd]**, refer to the user manual.

Command Channel

In the **[Complete settings]** menu, **[Command channel]** submenu the user can set the following value to **[Cmd channel 1]** and **[Cmd channel 2]**:

- Terminal board.
- Graphic display terminal.
- Embedded Modbus RTU.
- CANopen option module.
- Other fieldbus option module.
- Embedded Ethernet.

On the right-top of the graphic display terminal screen, the information of the active command is displayed:

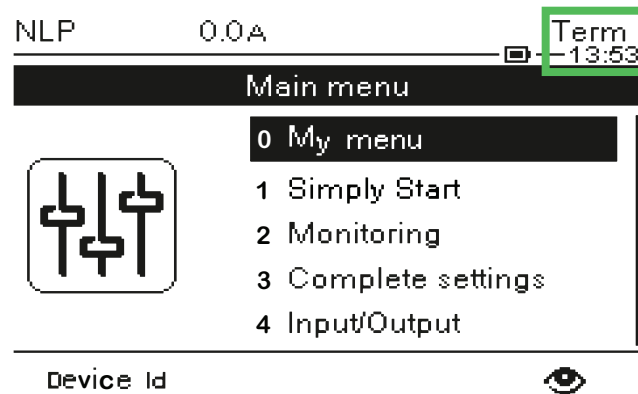

With **[Command Switching]**, user chooses which channel takes the command of the device by switching between **[Cmd channel 1]** and **[Cmd channel 2]**.

Access path: **[Complete settings]** → **[Command channel]**

Code	Settings	
[Command Switching] 	Logic address: 20E5 = 8421 CIP Path: 8B/01/16 = 139/01/22	Type: WORD (Enumeration) Read/write: R/WS
Command switching		
<h2 style="margin: 0;">⚠ WARNING</h2> <h3 style="margin: 0;">UNANTICIPATED EQUIPMENT OPERATION</h3> <p style="margin: 0;">This parameter can cause unintended movements, for example, inversion of the direction of rotation of the motor, sudden acceleration or stops.</p> <ul style="list-style-type: none"> • Verify that the setting of this parameter does not cause unintended movements. • Verify that the setting of this parameter does not result in unsafe conditions. <p style="margin: 0;">Failure to follow these instructions can result in death, serious injury, or equipment damage.</p>		
<p>This parameter sets which channel takes the command of the soft starter.</p> <ul style="list-style-type: none"> • [Cmd channel 1]: Channel 1 is the command channel (in this case, switching between [Cmd channel 1] and [Cmd channel 2] is not possible). • [Cmd channel 2]: Channel 2 is the command channel (in this case, switching between [Cmd channel 1] and [Cmd channel 2] is not possible). • [DI•]: Command channel switching assigned to digital input. • [Cy••]: Command channel switching assigned to line channel. <p style="margin-left: 40px;">NOTE: with Ethernet Embedded, use [C5••].</p> <p>When assigned to a digital input:</p> <ul style="list-style-type: none"> • [Cmd channel 1] active at low level. • [Cmd channel 2] active at high level. 		
[Active Command Channel] 	Logic address: 20FA = 8442 CIP Path: 8B/01/2B = 139/01/43	Type: WORD (BitString16) Read/write: R
<p>Active command channel</p> <p>Reading this value allows to monitor which is the active command channel who is controlling the device.</p> <ul style="list-style-type: none"> • Bit0 = 1 : Terminal board. • Bit2 = 1 : Display Terminal. • Bit3 = 1 : Embedded Modbus RTU. • Bit6 = 1 : CANopen option module. • Bit9 = 1 : Other fieldbus option module. • Bit11 = 1 : Embedded Ethernet. • Bit15 = 1 : SoMove (via control panel). 		

Command Register and Status — [Standard Profile]

What's in This Chapter

Functional Description	62
Operating State Diagram in [Standard Profile]	62
Device Status Summary	64
Description of Operating States in [Standard Profile]	64
Command Register in [Standard Profile]	65
Status Word	66
Stop and Halt Commands	67

Functional Description

Introduction

Soft starter operation involves one main function, which is illustrated in the diagrams below.

Altivar Soft Starter

The following figure shows the control diagram for soft starter operation:

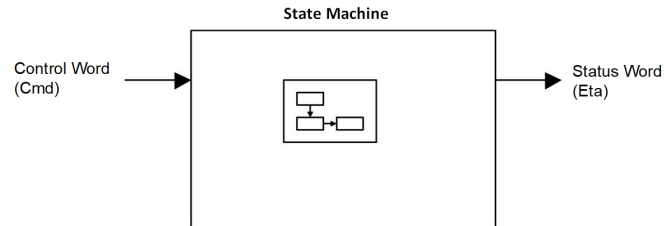

Operating State Diagram in [Standard Profile]

After switching on and when an operating mode is started, the product goes through a number of operating states.

The state diagram (state machine) shows the relationships between the operating states and the state transitions. The operating states are internally monitored and influenced by monitoring functions.

The following figure shows the [Standard Profile] state diagram:

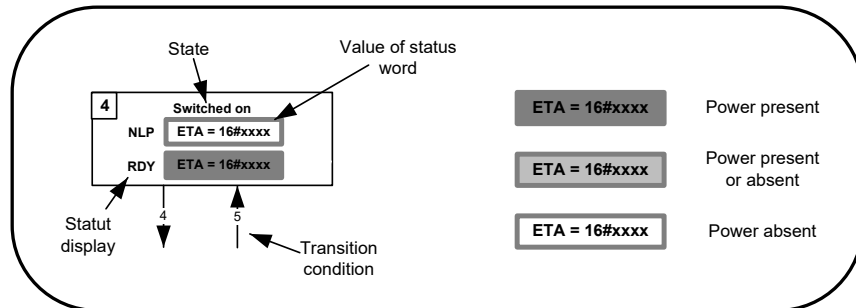
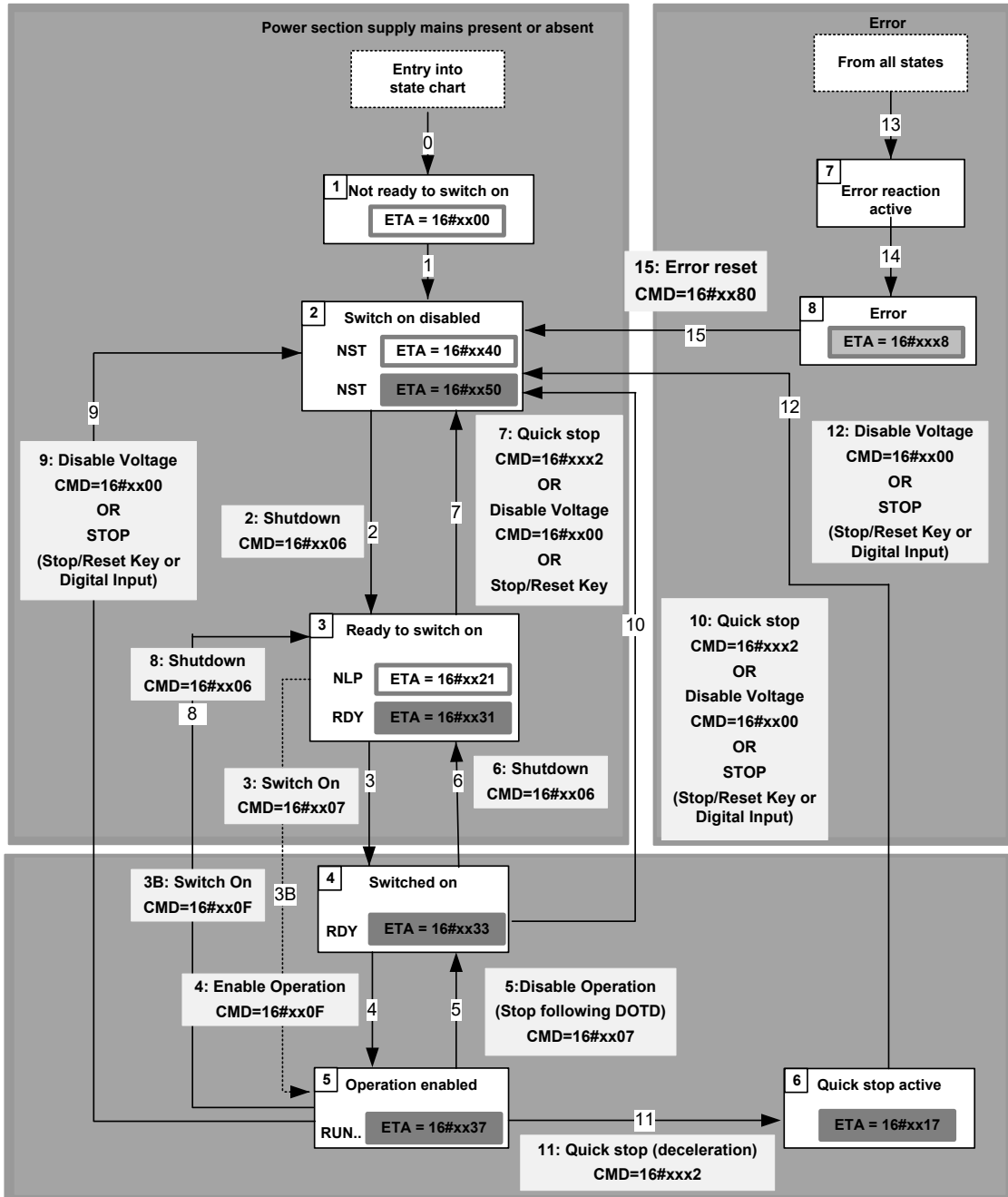

NOTE: The transition 3B is possible but not included in the CIA402 operating state diagram.

Device Status Summary

Operating State	Power Supply to Power Stage	Power Supplied to Motor	Modification of Configuration Parameters
1 - Not ready to switch on	Not required	No	Yes
2 - Switch on disabled	Not required	No	Yes
3 - Ready to switch on	Not required	No	Yes
4 - Switched on	Required	No	Yes
5 - Operation enabled	Required	Yes	No
6 - Quick stop active	Required	Yes, during deceleration	No
7 - Fault reaction active	Depends on error response configuration	Depends on error response configuration	No
8 - Fault	Not required	No	Yes

NOTE:

- Configuration parameters are described in communication parameter file as R/WS access type parameters.
- An adjustment parameter can be accessed in all operating state of the soft starter.

Description of Operating States in [Standard Profile]

Each state represents an internal reaction by the soft starter.

The operating state of the soft starter changes depending on whether the control word is sent to **[Cmd Register]** *CMD* or an event occurs (an error detection, for example).

The soft starter operating state can be identified by the value of the status word **[Status Register]** *ETA*. For more information, refer to the **[Status Register]** *ETA* chapter.

Operating State	Description
1 - Not ready to switch on	<ul style="list-style-type: none"> • Initialization starts. This is a transient state invisible to the communication network.
2 - Switch on disabled	<ul style="list-style-type: none"> • The power stage L1/L2/L3 is not ready to switch on. • The control stage A1/A2 must be supplied to set the configuration and adjustment parameters. • The soft starter is locked, no power is supplied to the motor.
3 - Ready to switch on	<ul style="list-style-type: none"> • The power stage L1/L2/L3 is ready to switch on. • With the control stage A1/A2 supplied, it is not necessary to supply the power stage, but the system expects it in order to change to state 4 - Switched on • The soft starter is locked, no power is supplied to the motor. • The configuration and adjustment parameters can be modified.
4 - Switched on	<ul style="list-style-type: none"> • Power stage is switched on. • The power stage of the soft starter is ready to operate, but voltage has not yet been applied to the output. • The adjustment parameters can be modified. <p>NOTE: By default, Relay R1 [R1 Assignment] is set to [Operating State Fault] then the mains contactor is closed. The soft starter is locked, no power is supplied to the motor.</p> <p>NOTE: If mains contactor is wired on a relay ([R1 Assignment], [R2 Assignment] or [R3 Assignment] is set to [Mains Contactor]), we reach temporarily this state once Run command is applied and mains contactor is closed allowing presence of power stage before switching to 5 - Operation enabled.</p> <p>For more information about Starting sequence, refer to Starting Sequence, page 75.</p>

Operating State	Description
5 - Operation enabled	<ul style="list-style-type: none"> Power stage is enabled. The soft starter is in running state. For a separate control stage with mains contactor, the contactor is closed. The soft starter is unlocked, power is supplied to the motor. The soft starter functions are activated and voltage is applied to the motor terminals. If the <code>Halt</code> command is applied, no power is supplied to the motor expect in preheating. The adjustment parameters can be modified. The configuration parameters cannot be modified. From this state the reaction of the soft starter to a <code>Disable operation</code> command depends on the value of the <code>[SwitchOnDisable Stp] DOTD</code> parameter: <ul style="list-style-type: none"> If the <code>[SwitchOnDisable Stp] DOTD</code> parameter is set to 0, the soft starter changes to operating state 4 - <i>Switched on</i> and stops in freewheel stop. If the <code>[SwitchOnDisable Stp] DOTD</code> parameter is set to 1, the soft starter stops following to the <code>[Type of stop]</code> and then changes to operating state 4 - <i>Switched on</i>.
6 - Quick stop active	<ul style="list-style-type: none"> The soft starter performs a deceleration ramp. After the motor has stopped, the soft starter switches to state 2 - <i>Switch on disabled</i>.
7 - Fault reaction active	<ul style="list-style-type: none"> Transient state during which the soft starter performs a stop due to a detected error. If behavior of the detected error is configurable, then the reaction will depend on setting of its error response.
8 - Fault	<ul style="list-style-type: none"> End of the stop caused by change to the previous state 7 - <i>Fault reaction active</i>. Power stage is disabled. The soft starter is locked, no power is supplied to the motor if an error detection has been triggered. Else the soft starter change to the step 2- <i>switch on disable</i>. The soft starter function is disabled.

Command Register in [Standard Profile]

[Cmd Register] is used to control the product defined as followed:

	Bit 0	Bit 1	Bit 2	Bit 3	Bit 4	Bit 5	Bit 6	Bit 7
Function	Switch	Enable / Disable voltage	Quick Stop	Operation Run command	Reserved			Error reset request
Bit at 0	Off.	Disable.	Activate.	Disable.				Active on rising edge.
Bit at 1	On.	Enable.	Deactivate.	Enable.				

	Bit 8	Bit 9	Bit 10	Bit 11	Bit 12	Bit 13	Bit 14	Bit 15
Function	Halt command	Reserved		Reverse Direction request (1) NOTE: for more information about Reverse function, refer to the user manual.	Manufacturer specific assignable	Dynamic braking stop (1)	Decelerated stop order (1)	Manufacturer specific assignable
Bit at 0	Request not sent.			Deactivate.		Deactivate.	Deactivate.	
Bit at 1	Stop following [Type of stop].			Activate.		Activate.	Activate.	

(1) The Bit can be set to an other function (factory setting).

NOTE: If no function is assigned, the Bit will return to his factory setting.

Bit Mapping of the Control Word

Command	State Transition	Final Operating State	Bit 7	Bit 3	Bit 2	Bit 1	Bit 0	Example Value
			Fault Reset	Enable Operation	Quick Stop	Enable Voltage	Switch On	
Shutdown	2, 6, 8	3 - Ready to switch on	X	X	1	1	0	0006 hex
Switch on	3	4 - Switched on	X	X	1	1	1	0007 hex
Enable operation	4	5 - Operation enabled	X	1	1	1	1	000F hex
Disable operation	5	4 - Switched on	X	0	1	1	1	0007 hex
Disable voltage	7, 9, 10, 12	2 - Switch on disabled	X	X	X	0	X	0000 hex
Quick stop	7, 10, 11	6 - Quick stop active	X	X	0	1	X	0002 hex
Fault reset	15	2 - Switch on disabled	0 → 1	X	X	X	X	0080 hex

X: Value is of no significance for this command.
 0→1: Command on rising edge.

Status Word

[Status Register] is used to gives status register as followed:

Code	Settings
[Status Register] ETA	Logic address: 0C81 hex = 3201 CIP Path: 71/01/02 hex = 113/01/02 Type: WORD (BitString16) Read/write: R Unit: -
Status Register	

	Bit 0	Bit 1	Bit 2	Bit 3	Bit 4	Bit 5	Bit 6	Bit 7
Function	Ready to Switch on	Switched on	Operation enabled Running	Detected error	Voltage enabled	Quick stop	Switch on disabled	Warning
Bit at 0	Not ready.	Not ready.	Not running.	No error.	Power stage supply absent.	Active.	Not active. Power section line supply opened.	No warning.
Bit at 1	Ready.	Ready.	Running.	Error is present.	Power stage supply present.	Not active.	Active. Power section line supply locked.	Warning is present.

	Bit 8	Bit 9	Bit 10	Bit 11	Bit 12	Bit 13	Bit 14	Bit 15
Function	Reserved	Local channel active	Reserved				Stop imposed by STOP key on graphic display terminal	Direction
Bit at 0		Active.					Activate.	Forward.
Bit at 1		Not active.					Deactivate.	Reverse.

Bit Mapping of the Status Word

Operating State	Bit 6	Bit 5	Bit 4	Bit 3	Bit 2	Bit 1	Bit 0	ETA Masked by 006F H ⁽¹⁾
	Switch On Disabled	Quick Stop	Voltage Enabled	Fault	Operation Enabled	Switched On	Ready to Switch On	
2 -Switch on disabled	1	0	X	0	0	0	0	0040 hex 0050 hex
3 -Ready to switch on	0	1	X	0	0	0	1	0021 hex 0031 hex
4 -Switched on	0	1	1	0	0	1	1	0033 hex
5 -Operation enabled	0	0	1	0	1	1	1	0037 hex
6 -Quick stop active	0	0	1	0	1	1	1	0017 hex
8 -Fault	X	X	X	1	0	0	0	xxx8 hex ⁽²⁾ ... xx28 hex

⁽¹⁾ This mask can be used by the PLC program to test the diagram state.

⁽²⁾ Detected error following operating state 6 - *Quick stop active*.

X: In this state, the value of the bit can be 0 or 1.

Stop and Halt Commands

BIT 13 and BIT 14 of Command register

Only available if [Control Mode] is set to [Standard Profile]. When **dynamic braking stop** or **decelerated stop order** is activated, the soft starter performs a **braked stop** or a **decelerated stop** and remains locked in the operating state 5 - *Operation enabled*.

BIT 8 : Halt command

Only available if [Control Mode] is set to [Standard Profile]. The `Halt` command enables movement to be interrupted without having to leave the 5 - *Operation enabled* state. The stop is performed in accordance with the [Type of stop] `STT` parameter.

If the `Halt` command is active, no power is supplied to the motor and no torque is applied.

I/O Profile

I/O Profile via **[Control Mode]** is set to **[I/O profile]**.

As well as physical digital inputs commanding the soft starter in terminal command, the soft starter can be commanded by line channel and each bit of the control word can be assigned to a dedicated function if the bit is free. **[I/O profile]** makes it possible to go from 4 physical digital inputs to 16 virtual digital inputs.

NOTE: The customer must monitor the **[Device State]** [HMIS](#).

NOTE: When communication is used to control the soft starter and **[2/3-Wire Control]** is set to **[3-Wire Control]** / **[Hardwired ctrl mode]**, DI1 must be connected to the +24V

Code	Settings	
[Cmd Register] CMD	Logic address: 2135 hex = 8501 CIP Path: 8B/01/66 hex = 139/01/102	Type: WORD (BitString16) Read/write: R/W
<p>Command register If the [2/3-Wire Control] parameter is set to :</p> <ul style="list-style-type: none"> [2-Wire Control], the Command register bits are: <ul style="list-style-type: none"> Bit0 : Run enable + Forward Direction Bit1 to Bit15 : Free [3-Wire Control] / [Hardwired ctrl mode] , the Command register bits are: <ul style="list-style-type: none"> Bit0 : Run enable Bit1 : Forward Direction Bit2 to Bit15 : Free 		

A function input can be assigned to:

- A virtual input (Cd00 to Cd15) according to the active command channel, corresponding bit of the control word or digital input of the terminal must be used to activate / deactivate the function.
- A terminal input (DI1 to DI4) irrespective of the active command channel, the function can be activated / deactivated using the corresponding digital input (exception for some function that requires to have the terminal as active command channel to activate / deactivate the function).

The function **[Command Switching]** can be activated / deactivated, irrespective of the active command channel, using the corresponding bit of a terminal input or of the control word **[Cy●●]**:

- A modbus control word (**[C100]** to **[C115]**)
- A CANopen control word (**[C200]** to **[C215]**).
- A fieldbus module, such as PROFIBUS, control word (**[C300]** to **[C315]**).
- An embedded ethernet control word (**[C500]** to **[C515]**)

Bit	Fixed assignments		
	Virtual Inputs	Terminals	Embedded Ethernet
bit 0	Cd00	DI1	C500
bit 1	Cd01	DI2	C501
bit 2	Cd02	DI3	C502
bit 3	Cd03	DI4	C503
bit 4	Cd04	-	C504
bit 5	Cd05	-	C505
bit 6	Cd06	-	C506
bit 7	Cd07	-	C507

Bit	Fixed assignments		
	Virtual Inputs	Terminals	Embedded Ethernet
bit 8	Cd08	-	C508
bit 9	Cd09	-	C509
bit 10	Cd10	-	C510
bit 11	Cd11	-	C511
bit 12	Cd12	-	C512
bit 13	Cd13	-	C513
bit 14	Cd14	-	C514
bit 15	Cd15	-	C515

Switched assignment

When **[Control Mode]** is set to **[I/O profile]**, the transition of the active command channel to fieldbus does not follow the configuration of the parameters **[2/3-Wire Control]** and **[2-wire type]**. An immediate start will be observed if a run command is active on the **[Cmd Register] CMD**.

⚠ WARNING

UNANTICIPATED EQUIPMENT OPERATION

- Verify that this behavior does not result in unsafe conditions by performing extensive commissioning tests.
- If the start on transition is not desired, the bits corresponding to the run command must always be reset before switching the active command channel to fieldbus.

Failure to follow these instructions can result in death, serious injury, or equipment damage.

Example with:

- **[Command Switching]** managed by digital input.
- A function assigned to a switched bit (here **CD02**).
- B function assigned to a digital input (here **DI4**).
- **[Cmd channel 1] = [Embedded Ethernet]**.
- **[Cmd channel 2] = [Terminal]**.

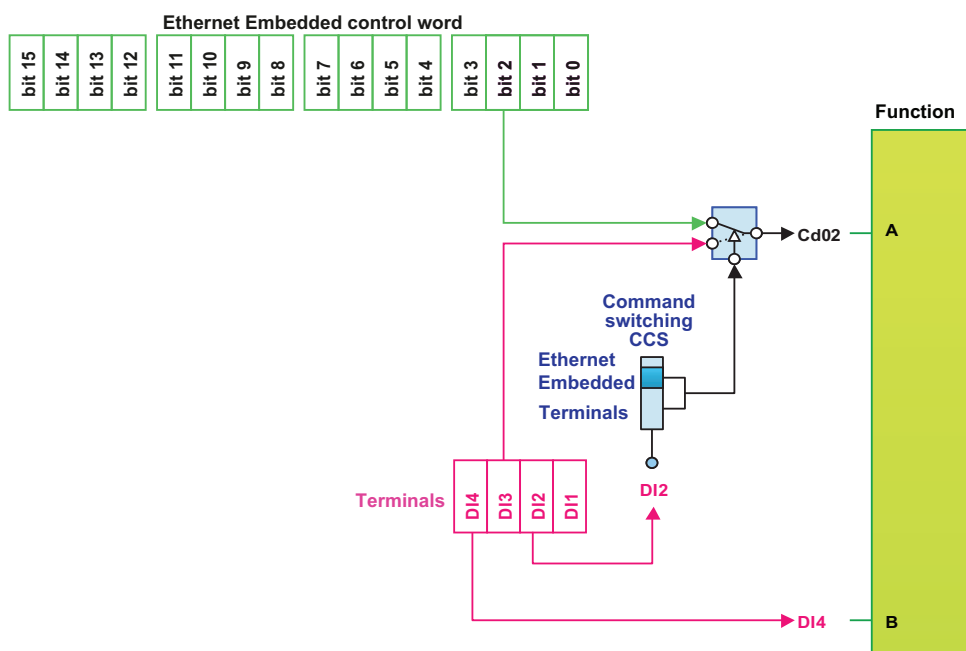

Example with:

- **[Command Switching]** managed by control word (here **C505**).
- A function assigned to a switched bit (here **CD02**).
- B function assigned to a digital input (here **DI4**).
- **[Cmd channel 1] = [Embedded Ethernet]**.
- **[Cmd channel 2] = [Terminal]**.

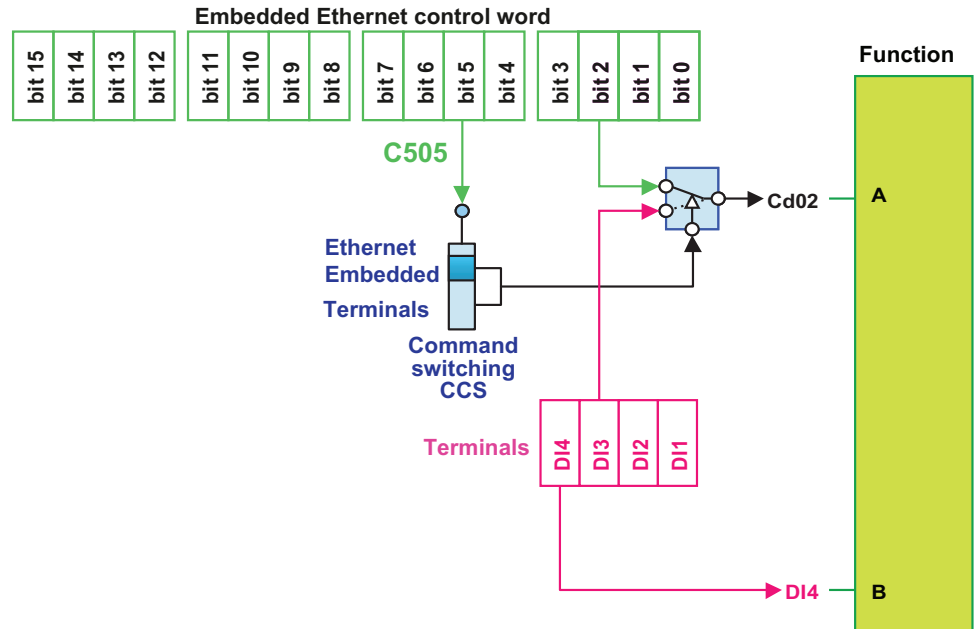

When a function is assigned to a switched bit (Cd00 to Cd15), the function can be activated via Terminals or selected communication channel according to the active command channel. To switch between Terminals and communication modules, use **[Command Switching]** function.

NOTE: A single function can be assigned to a bit at the same time, here as **[C505]** is assigned to **[Command Switching]**, Cd05 cannot be assigned to another function.

Exemple: I/O profile with monitoring of tank by flow sensors

In this example, a PLC is used to monitor the water level in a tank.
 The soft starter is used to manage some functions as anti-jam.
 The PLC and the soft starter are connected via an Ethernet network. The PLC controls the operation of the installation via the Ethernet bus.

Configuration

- **[Control Mode]** is set to **[I/O profile]**.
- **[2/3-Wire Control]** set to **[2-Wire Control]**.
- **[Reverse Assign]** set to **[CD01]**
- **[Fault Reset Assign]** set to **[CD05]**
- **[Ext Anti-Jam Trigger]** set to **[CD06]**.
- **[Cmd channel 1]** set to **[Ethernet Embedded]**.

Configuration schematic diagram:

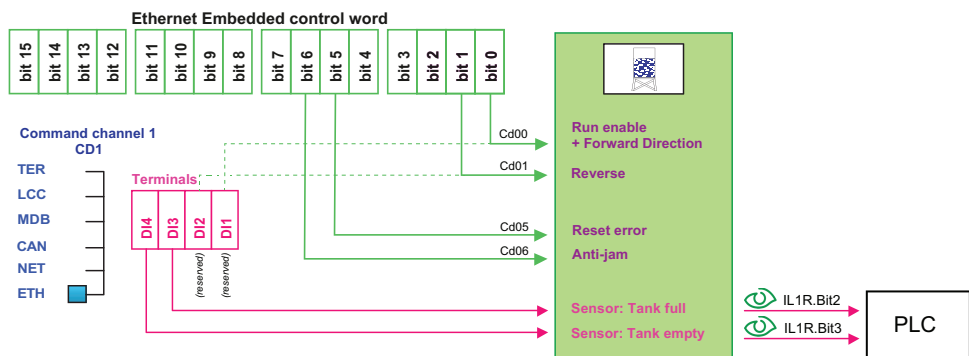

NOTE: Some digital inputs are reserved because bits are already assigned.

In our example:

- Cd00 is assigned to **Run enable + Forward direction**.
 - Cd01 is assigned to **Reverse**.
- ➔ DI1 and DI2 cannot be assigned.

Extended Control Word and Internal State register in [Standard Profile] & [I/O Profile]

What's in This Chapter

Extended Control Word.....	73
Internal State register	74

Extended Control Word

When a configuration parameter is modified by fieldbus, it is not stored automatically in the EEPROM. The value will be lost after a power cycle if the request to store the new configuration has not been done.

⚠ WARNING
LOSS OF PARAMETER CONFIGURATION AFTER A POWER CYCLE
Bit 1 of [Extended Control Word] CMI must be written at 1 each time the configuration is modified by fieldbus.
Failure to follow these instructions can result in death, serious injury, or equipment damage.

NOTE: Do not write **[Extended Control Word]** BITs cyclically (especially BIT 1), as this may damage the EEPROM.

[Extended Control Word] is used to control the product defined as followed:

Code	Settings	
[Extended Control Word] CMI	Logic address: 2138 hex = 8504 CIP Path: 8B/01/69 hex = 139/01/105	Type: WORD (BitString16) Read/write: R/W Unit: -
Extended control word		

	Bit 0	Bit 1	Bit 2	Bit 3	Bit 4	Bit 5	Bit 6	Bit 7
Function	Restore factory settings	Store customer parameters	Restore saved customer parameters	External error	Reserved			
Bit at 0	Active on rising edge when motor is powered off.	Active on rising edge.	Active on rising edge when motor is powered off. Once request is considered, this bit is automatically reset.	Active on rising edge.				
Bit at 1	Once request is considered, this bit is automatically reset.	Once request is considered, this bit is automatically reset.						

	Bit 8	Bit 9	Bit 10	Bit 11	Bit 12 In [Standard Profile]:	Bit 12 In [I/O profile]:	Bit 13	Bit 14	Bit 15
Function	Reserved				Reverse direction request	Reserved	Lock device when motor stopped	Reserved (must always be set to 0).	Disable parameter consistency check
Bit at 0					Request not sent.		Deactivate.		All parameters are validated.
Bit at 1					Request sent. Motor can start in reverse direction (only if CMD bit 11 is assigned to specific function other than reverse).		Activate.		No check of parameter consistency and device is locked when stopped.

Internal State register

[Internal State Reg] is used to gives the extended internal status register as followed:

Code	Settings	
[Internal State Reg] ETI	Logic address: 0C86 hex = 3206 CIP Path: 71/01/07 hex = 113/01/07	Type: WORD (BitString16) Read/write: R Unit: -
Internal State register		

	Bit 0	Bit 1	Bit 2	Bit 3
Function	<i>Write parameter authorization</i>	<i>Parameter consistency check</i>	<i>Starter reset authorization</i>	<i>Motor preheating</i>
Bit at 0	Access to the non-volatile memory stopped.	Not active.	The device: <ul style="list-style-type: none"> is not in operating state "Error" is in operating state "Error" and the error is active. 	Not active.
Bit at 1	Access to the non-volatile memory in progress.	Active.	The device is in operating state "Error" and the error is no longer active (not reset).	Active.

	Bit 4	Bit 5	Bit 6	Bit 7
Function	<i>Motor operating status</i>	<i>Braking</i>	<i>Starter in continuous operation</i>	<i>Thermal overload warning:</i>
Bit at 0	Not active.	Not active.	Transient state.	Threshold for the active motor not reached.
Bit at 1	Active.	Active.	Steady state.	Threshold for the active motor reached.

	Bit 8	Bit 9	Bit 10	Bit 11
Function	<i>Reserved</i>	<i>Starter accelerating</i>	<i>Starter decelerating</i>	<i>Current limit warning</i>
Bit at 0		Not active.	Not active.	Not active.
Bit at 1		Active.	Active.	Active.

	Bit 12	Bit 13	Bit 14	Bit 15
Function	<i>Torque limit warning</i>	<i>Active mode:</i>		<i>Direction</i>
Bit at 0	Not active.	<ul style="list-style-type: none"> Bit 13 = 0 + Bit 14 = 0: Device controlled by terminal Bit 13 = 1 + Bit 14 = 0: Device controlled by the display terminal Bit 13 = 0 + Bit 14 = 1: Device controlled by Embedded Modbus Bit 13 = 1 + Bit 14 = 1: Device controlled by fieldbus card 		Forward operation applied before the ramp.
Bit at 1	Active.			Reverse operation applied before the ramp.

Starting Sequence

What's in This Chapter

Sequence for a Soft starter..... 76
 Sequence for a Soft starter with Mains Contactor Control 79

Description

The command sequence in the state diagram depends on how power is being supplied to the soft starter.

NOTE: This example is given when [Control Mode] is set to [Standard Profile].

There are 2 possible scenarios:

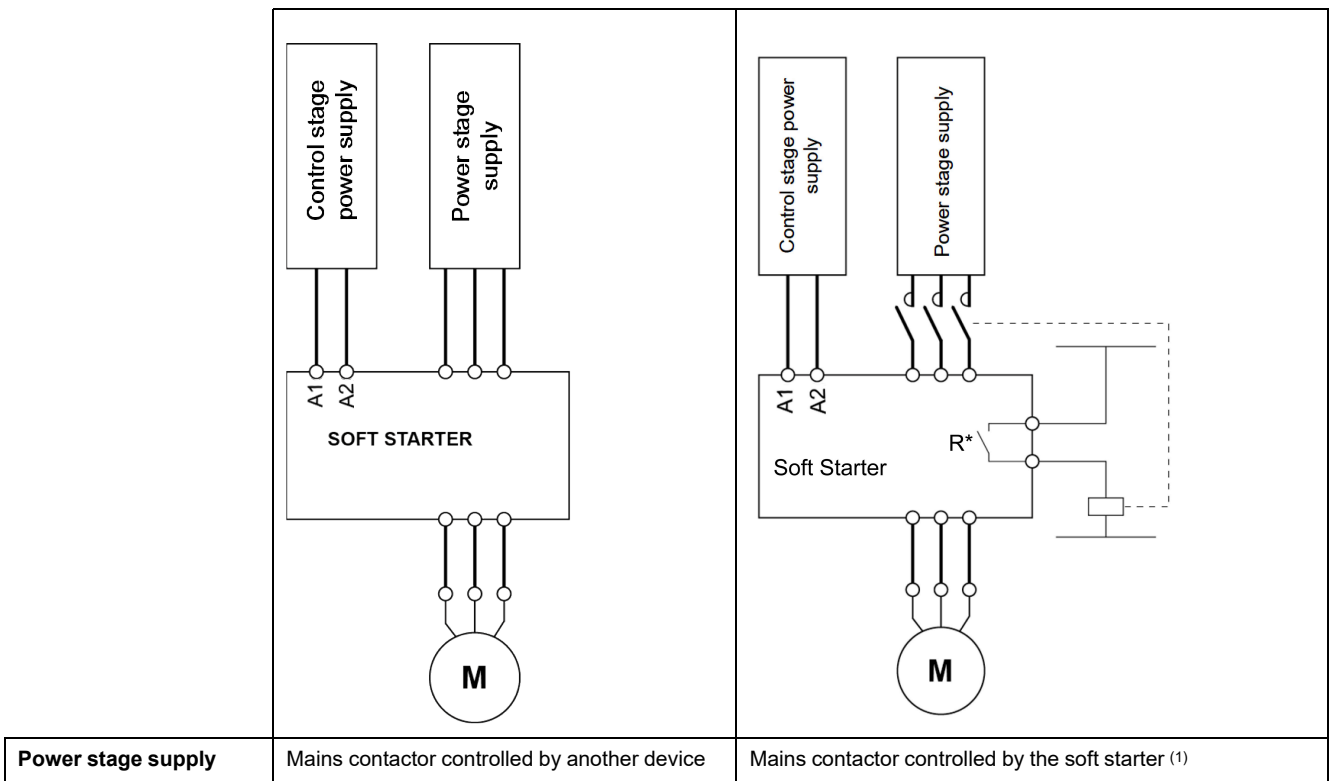

NOTE:

⁽¹⁾ and R*: [R1 Assignment] R1, [R2 Assignment] R2 or [R3 Assignment] R3 assigned to [Mains Contactor].

NOTE: If [Mains Contactor] is set to a specific relay (R1, R2 or R3) no other relay can be assigned to this function.

Sequence for a Soft starter

Description

Power is supplied separately to the power and control stages. The following sequence must be applied:

Step 1

- In **[Standard Profile]**, **[Cmd channel 1]** or **[Cmd channel 2]** must be set to the **[Ethernet Embedded]** and active.
- The power stage supply is not necessarily present.
- Apply the 2 - *Shut down* transition command.

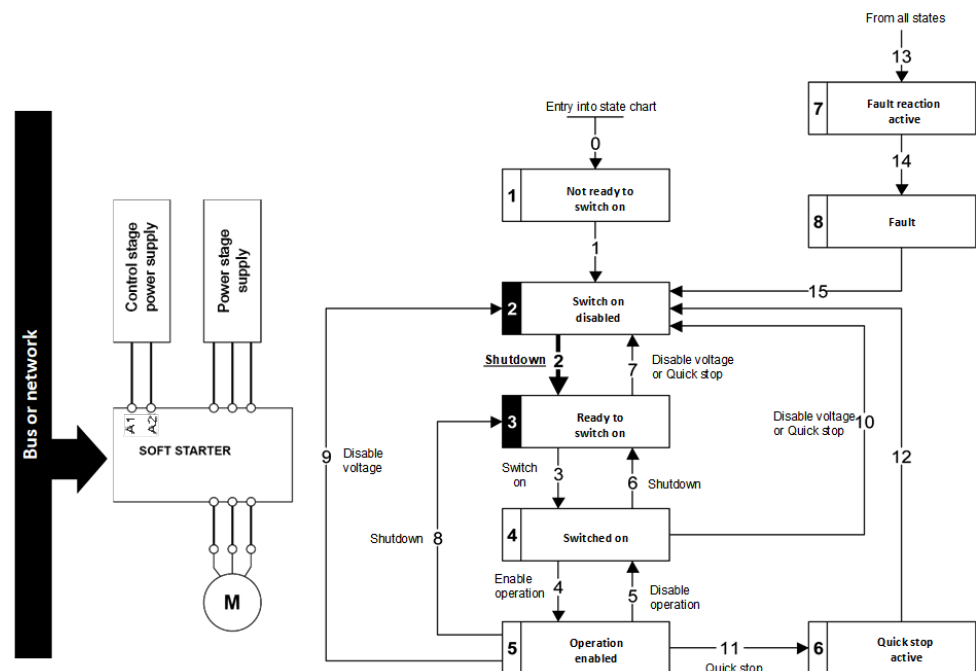

Step 2

- Check that the soft starter is in the operating state 3 - *Ready to switch on*.
- The power stage supply could be present (*Voltage enabled* of the status word).

Power Stage Supply	Terminal Display	Status Word
Absent	NLP	21 hex
Present	RDY	31 hex

- Apply the 3 - *Switch on* transition command

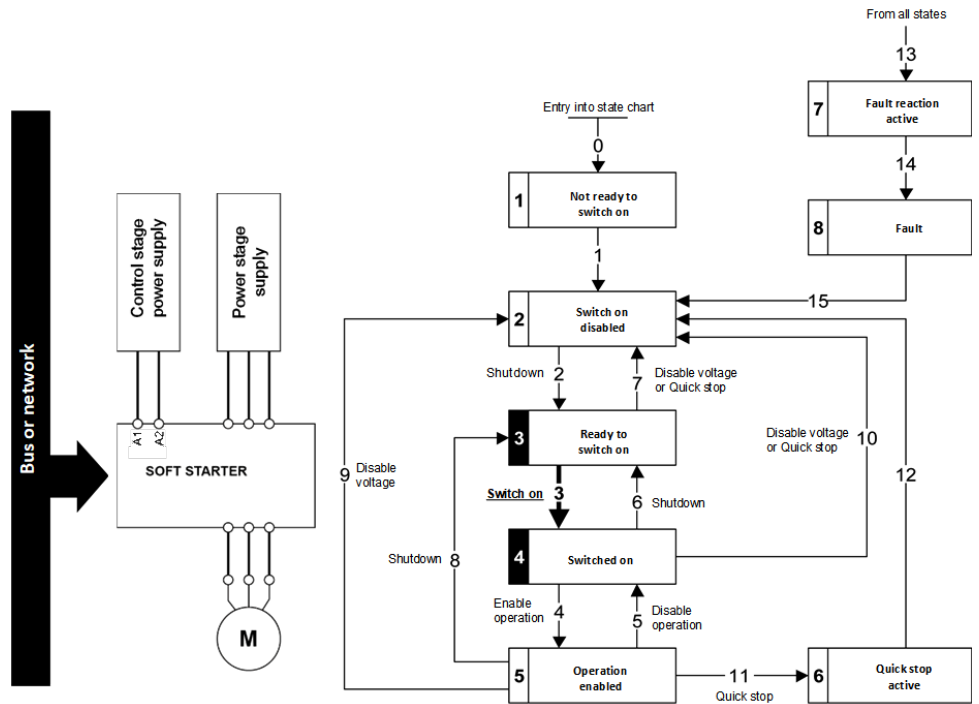

Step 3

- If power supply is present; check that the soft starter is in the operating state 4 - *Switched on*.
NOTE: If power supply is not present, we stay in 3 - *Ready to switch on*.
- Then apply the 4- *Enable operation* transition command.
- The motor starts.

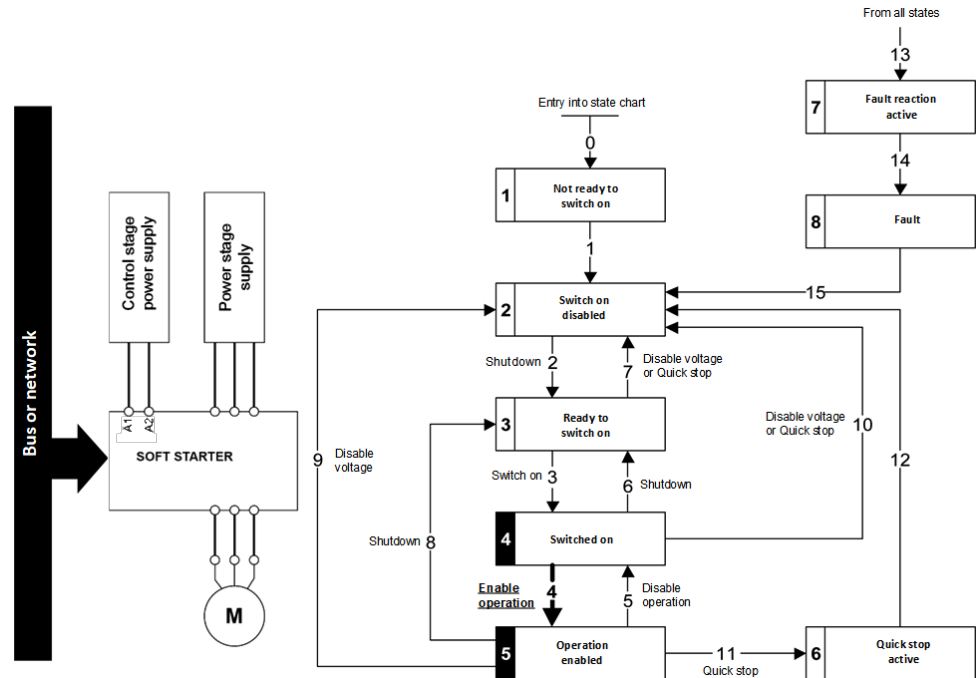

Sequence for a Soft starter with Mains Contactor Control

Description

Power is supplied separately to the power and control stages. If the soft starter controls the mains contactor the following sequence must be applied:

Step 1

- In **[Standard Profile]**, **[Cmd channel 1]** or **[Cmd channel 2]** must be set to the **[Ethernet Embedded]** and active.
- The power stage supply is not present as the mains contactor is not being controlled.
- Apply the **2 - Shut down** transition command.

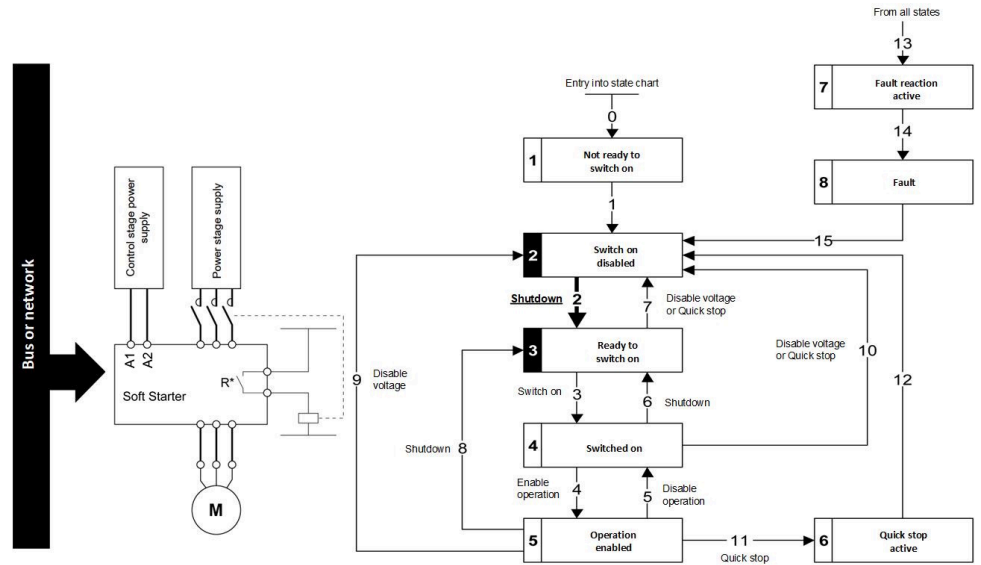

Step 2

- Check that the soft starter is in the operating state 3 - *Ready to switch on*.

Power Stage Supply	Terminal Display	Status Word
Absent	NLP	21 hex

- Apply the 3 - *Switch on* transition command.

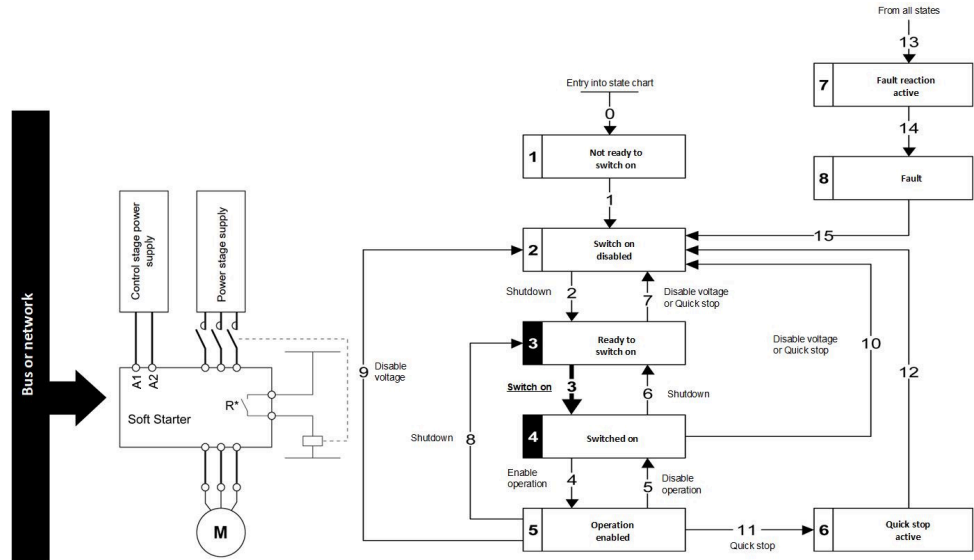

Step 3

- Apply the 4- *Enable operation* transition command which closes the mains contactor and switch on the power stage supply by giving RUN command.

NOTE: If the power stage supply is still not present in the operating state 5 - *Operation enabled* after a time delay [**Mains V. time out**], the soft starter triggers an error [**Input Contactor**].

- The motor starts.

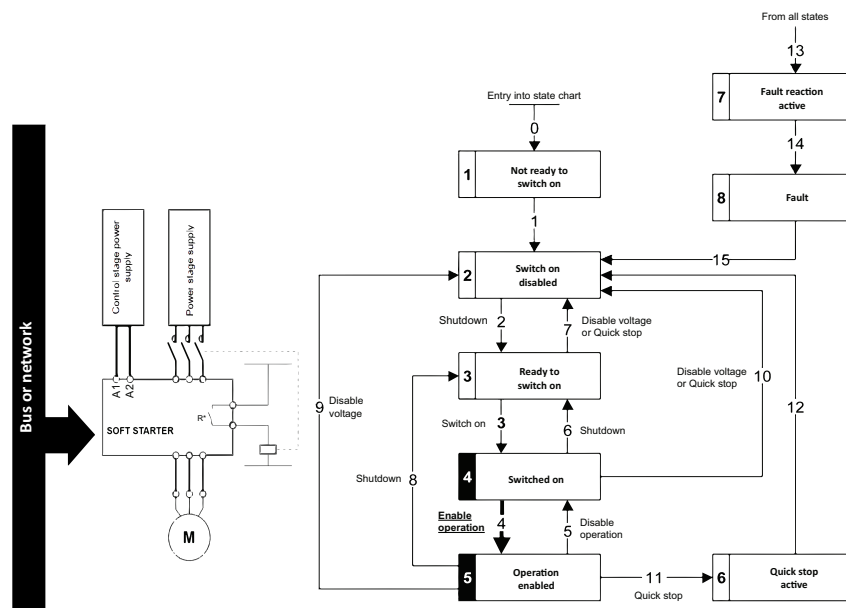

Monitoring of Communication Channel

Communication channels are monitored if they are involved in the control word **[Cmd Register]** from the active command channel.

As soon as this register has been written once to a communication channel, it activates monitoring for that channel.

If an interruption of communication is triggered in accordance with the protocol criteria by a monitored port, the soft starter react according to **[Eth Error Response]** configuration, refer to [Configuring Communication Error Response](#), page 113 for more information.

If an interruption of communication is triggered on a channel that is not being monitored, the soft starter does not trigger a communication error/warning.

Network Layer Supported Functions/Protocols

ARP Protocol

The ARP (Address resolution protocol) is a protocol used to map network addresses (IP) to hardware addresses (MAC).

The protocol operates below the network layer as a part of the OSI link layer, and is used when IP is used over Ethernet. A host, wishing to obtain a physical address, broadcasts an ARP request onto the TCP/IP network. A unique IP address is assigned to the host, and is sent to its hardware address.

ICMP Protocol

The embedded port manages the ICMP protocol.

- ICMP client: not supported
- ICMP server: the managed requests are the following:

Type	Description
0	Echo reply (ping)
3	Destination unreachable
4	Sources quench
5	Redirect
6	Alternate host address
8	Echo request (ping)
9	Router advertisement
10	Router solicitation
11	Time exceeded
12	Parameter problem
13	Time stamp request
14	Time stamp reply
15	Information request
16	Information reply
17	Address mask request
18	Address mask reply

IP Protocol

The Ethernet port implements the IPV4 and IPV6 (for DPWS) protocols.

SNMP Services

The Ethernet port accepts the community name “private” for writing and the community name “public” for Reading.

MIB

Objects	Description	Access	Default Value
SysDescr	Text description of the product	Read only	
SysObjectID	Points in the private MIB on the product part number	Read only	Embedded: 1.3.6.1.4.1.3833.1.100.4.5
SysObjectRef	Soft starter reference	Read only	ATS4XX
SysUpTime	Time elapsed since the last power-up	Read only	Managed by the product
SysContact	Information allowing to contact the node manager	Read/write	" "
SysName	Node administrative name	Read/write	Device name
SysLocation	Physical location of the product	Read/write	" "
SystemService	Indicates the service type offered by the product.	Read only	72

TCP and UDP Protocol

BOOTP and DHCP Protocol

The following table describes the DHCP frame format:

OP (1 byte)	HTYPE (1 byte)	HLEN (1 byte)	HOPS (1 byte)
XID (4 bytes)			
SECS (2 bytes)		FLAGS (2 bytes)	
CIADDR (4 bytes)			
YIADDR (4 bytes)			
SIADDR (4 bytes)			
GIADDR (4 bytes)			
CHADDR (16 bytes)			
SNAME (64 bytes)			
FILE (128 bytes)			
OPTIONS (312 bytes)			

DHCP frame fields are described as follows:

Field	Description
op	Message type DHCP request / DHCP reply
htype	Address hardware type
hlen	Hardware address length
hops	Used by relay agent
xid	Transaction identifier, random number chosen by the client allowing to associate the request and the response
secs	Time in seconds since the beginning of the transaction
flags	First bit used for the broadcast reply flag
ciaddr	Client IP address, only used if the client can respond to ARP request
yiaddr	Client IP address, "your" IP address proposed by the server
siaddr	IP address of the server
giaddr	Gateway IP address, used when a relay agent needs to be crossed
sname	Server name
file	Location of boot file
options	Optional parameters with DHCP extensions

DHCP Message

The DHCP protocol uses 8 different types of message during the IP assigning process.

The following table describes the 8 messages:

Message	Description
DISCOVER	The client tries to discover the DHCP server using a broadcast
OFFER	The server proposes a configuration
REQUEST	The client chooses a DHCP server and declines other offers
ACK	The chosen server assigns the IP configuration
NAK	The server rejects the client request
DECLINE	The client declines the assigned IP configuration
RELEASE	The client releases its IP address before the end of the lease
INFORM	The client asks for network information (it already has an IP address)

Operating Modes

The choice between DHCP, BOOTP, and fixed configuration is made through one parameter:

- Fixed: the Ethernet adapter uses the address stored in parameter.
- BOOTP: the Ethernet adapter receives the addresses from BOOTP server.
- DHCP: if the device name [XXX] is valid, the Ethernet adapter receives the addresses from the DHCP server.

Modbus TCP Features

What's in This Chapter

Modbus TCP Frames..... 86
 Modbus TCP Servers 87
 Supported Modbus TCP Functions 87

Modbus TCP Frames

TCP Telegrams

Modbus TCP telegrams are not only Modbus standard requests and responses encapsulated in TCP frames.

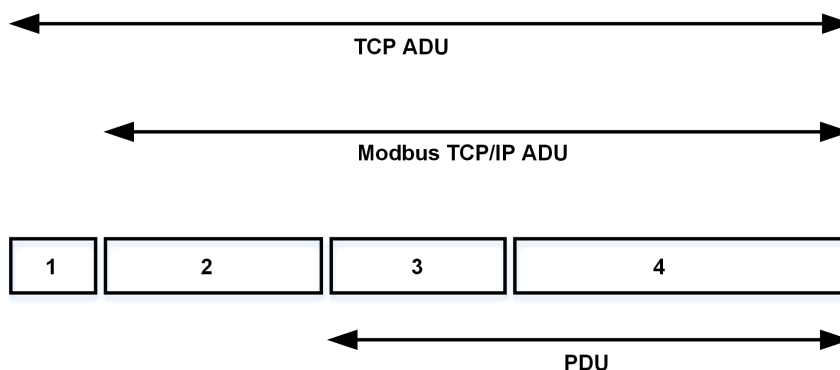

- 1 TCP header
- 2 MBPA: Modbus application protocol header
- 3 ADU: Application data unit
- 4 PDU: Protocol data unit (The Modbus message itself)

MBAP Header Structure

Fields	Length	Description	Client	Server
Transaction identifier	2 bytes	Identification of a Modbus request / response transaction	Initialized by the client	Recopied by the server from the received request
Protocol identifier	2 bytes	0= Modbus protocol	Initialized by the client	Recopied by the server from the received request
Length	2 bytes	Number of following bytes	Initialized by the client (request)	Initialized by the server (response)
Unit identifier	1 byte	Identification of a remote server connected on a serial line or on other buses	Initialized by the client	Recopied by the server from the received request

Modbus TCP Servers

Overview

Unit ID	Modbus TCP server	Accessible parameters
0/248	Soft starter	See the file related to soft starter communication parameters.
255	Soft starter I/O scanner	See I/O scanner setting, page 88

Supported Modbus TCP Functions

Modbus TCP Services

The Modbus TCP supports the following services:

Function Name	Code		Description	Remarks
	Dec	Hex		
Read holding registers	03	03 hex	Read N output words	Max PDU length: 125 words
Write 1 output word (Unit ID 0-248 only)	06	06 hex	Write 1 output word	–
Write multiple registers	16	10 hex	Write N output word	Max PDU length: 123 words
Read/write multiple registers (Unit ID 0-248 and 255)	23	17 hex	Read/write multiple registers	Max PDU length: 121 words (W), 125 words (R)
(Subfunction) Read device identification	43/14	2B hex 0E hex	Encapsulated interface transport / read device identification	See the table below

Identification

Id	Value	Comment
00 hex	Schneider Electric	Device manufacturer
01 hex	ATS4XX	Soft starter commercial part number
02 hex	0101	Soft starter version
04 hex	–	–
05 hex	–	–
06 hex	Customized Name	Device name

I/O Scanning Service

The I/O scanning service is used to exchange periodic I/O data between:

- A controller or PLC (I/O scanner).
- Devices (I/O scanning servers).

This exchange is performed by implicit requests, thus avoiding the need to program the controller (PLC).

The I/O scanner periodically generates the read/write multiple registers (23 = 17 hex) request. The I/O scanning service operates if it has been enabled in the PLC and in the soft starter. The soft starter parameters assigned to I/O scanning have been selected by default. This assignment can be modified by configuration.

When the I/O scanning service has been enabled in the soft starter:

- A TCP connection is assigned to it.
- The parameters assigned in the periodic variables are exchanged cyclically between the Ethernet adapter and the soft starter.
- The parameters assigned to the periodic output variables are reserved for I/O scanning. They cannot be written by other Modbus services, even if the I/O scanner is not sending its periodic output variables.

I/O Scanner Setting

The communication scanner is configurable through the commissioning tools.

Channel	Factory Setting	
Output 1	Command register (8501)	CMD (8501)
Output 2	Logic outputs states (5212)	OLLR (5212)
Output 3	AQ1 physical value (5271)	AOIC (5271)
Output 4	Counter reset (2120)	RPR (2120)
Up to output 32	0	0
Input 1	Status Register (3201)	ETA (3201)
Input 2	Motor current (3204)	LCR (3204)
Input 3	Motor thermal state (9630)	THR (9630)
Input 4	CiA402 error code (8606)	ERRD (8606)
Input 5	Motor run time (3244)	RTH (3244)
Input 6	[Elc Energy Cons] (10562)	OCK (10562)
Input 7	Logic inputs states (5202)	ILLR (5202)
Input 8	Active command channel (8442)	CCC (8442)
Up to Input 32	0	0

EtherNet/IP Features

What's in This Chapter

EtherNet/IP 89
 Cyclical Exchanges (Implicit Exchanges) 89
 Messaging (Explicit Exchanges) 90

EtherNet/IP

EtherNet/IP Fieldbus Features Overview

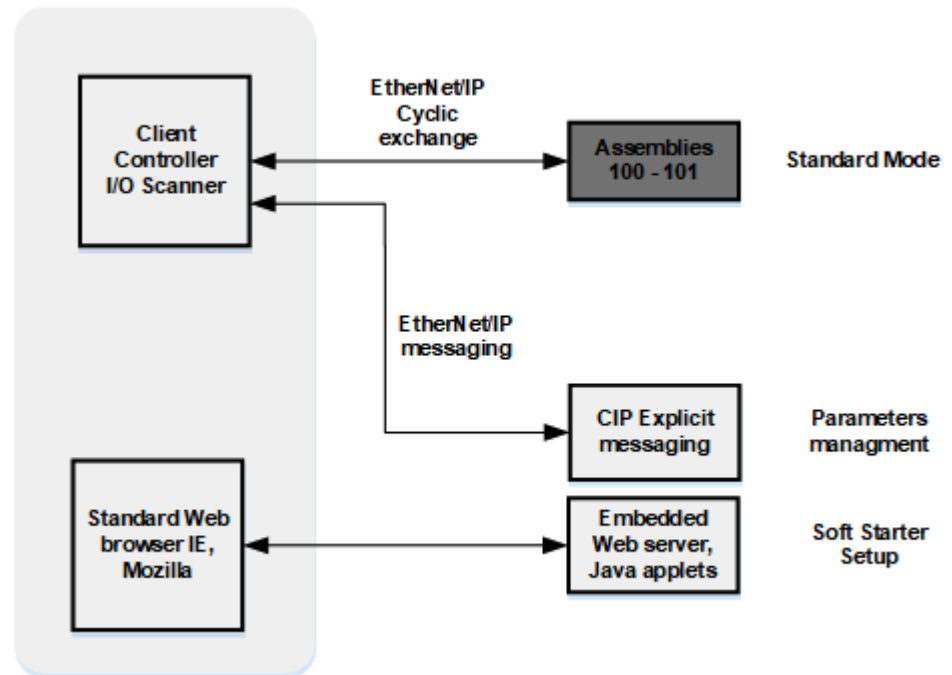

The Ethernet adapter supports the following profiles:

- Soft starter standard profile for assembly 100 and 101.

In addition to these cyclic exchanges, the adapter also supports explicit messaging.

Cyclical Exchanges (Implicit Exchanges)

Overview

This part gives a description of the assembly sets and how to configure them.

Principle of Control Configuration

By the configuration of the control, it is possible to decide from which channel the soft starter receives its commands either permanently or depending on a switching command. Numerous configurations are possible. For more information, refer to the user manual. The following configurations are some of the available possibilities.

The selection of the assembly set is made with the Ethernet Embedded.

Messaging (Explicit Exchanges)

Introduction

Parameters of the soft starter can be accessed by R/W as CIP objects.

Altivar Parameters Path

The soft starter parameters are grouped in classes:

- Each application class has only one instance.
- Each instance groups 200 parameters.
- Each attribute in an instance relates to a parameter.

The first parameter registered in the first application class (class code: 70 hex = 112) has the logical address 3000.

NOTE: For more details, refer to *Application Object (70 hex to C7 hex) / Explicit Messaging*, page 102.

CIP Object

What's in This Chapter

Supported Object Classes 91
 Identity Object (01 hex)..... 92
 Message Router Object (02 hex) 95
 Assembly Object (04 hex) 96
 Connection Manager Object (06 hex)..... 98
 Modbus Object (44 hex)..... 101
 Application Object (70 hex to C7 hex) / Explicit Messaging 102
 Port Object (F4 hex) 104
 TCP/IP Interface Object (F5 hex)..... 105
 Ethernet Link Object (F6 hex)..... 108

Supported Object Classes

Introduction

Two categories of object classes can be defined:

- CIP device on EtherNet/IP
- Communications Adapter Device (0x0C) Profile

These objects are detailed in the following table:

Object class	Class ID	Cat.	No. of instances	Effect on behavior interface
Identity	01 hex	1	1	This object provides identification of and general information about the device
Message router	02 hex	1	1	The Message Router Object provides a messaging connection point through which a Client may address a service to any object class or instance residing in the physical device
Assembly	04 hex	2	12	The Assembly Object binds attributes of multiple objects, which allows data to or from each object to be sent or received over a single connection.
Connection manager	06 hex	1	1	Use this object for connection and connectionless communications, including establishing connections across multiple subnets.
Modbus Object	44 hex	1	1	ODVA describes how to encapsulate a Modbus frame using a CIP object. Modbus Class Object presents the ethernet IP interface with the Modbus encapsulation service defined in the ODVA.
Application	70 hex to C7 hex	3	1	Vendor-specific object - soft starter parameters.
Port Object	F4 hex	1	1	The port object represents the underlying interface of CIP which is EtherNet/IP.
TCP/IP interface	F5 hex	1	1	TCP/IP configuration.
Ethernet link	F6 hex	1	1	Counter and status information.

Identity Object (01 hex)

Overview

This object provides identification of and general information about the device.

Class Code

Hexadecimal	Decimal
01 hex	1

Class Attributes

Attribute ID	Access	Name	Data type	Value	Details
1	Get	Revision	UINT	X	Revision index of the class
2	Get	Max instances	UINT	1	1 defined instance
3	Get	Number of instances	UINT	1	–
6	Get	Max ID of class attributes	UINT	7	–
7	Get	Max ID of instance attribute	UINT	7	–

Instance Attributes

Attribute ID	Access	Name	Data type	Value	Details
1	Get	Vendor ID	UINT	0x00-F3	–
2	Get	Device type	UINT	0x00-0C	The value retrieved using the service GetDeviceType.
3	Get	Product code	UINT	0x18-0B.	The value retrieved using the service GetDeviceType.
4	Get	Revision	Struct of: USINT USINT	x	GetSoft starterVersion
5	Get	Status	WORD	–	See definition in the following table
6	Get	Serial number	UDINT	–	First byte: 18 hex Second...Fourth byte: last 3 bytes of MAC-ID
7	Get	Product name	Struct of: USINT STRING	–	ATS4XX

Attribute 5–Status

Bit	Definition	How
0	Owned by client (predefined client/server connection)	No interface
2	Configured	If any of the product (option + soft starter) NVS attributes has changed from their error (out of box values). NOTE: Network communications attributes are not included here.
4 - 7	Extended device status: See below	–
8	Minor recoverable error	No minor recoverable error.
9	Minor unrecoverable error	No minor unrecoverable error.
10	Major recoverable error	[Embd Eth Com Interrupt] ETHF detected error or CIP connection timeout or Ethernet network overload.
11	Major unrecoverable error	[Internal Link Error] ILF detected error, EEPROM failed, OB hardware detected error.
Others	Reserved 0	–

Bit 4-7 Definition

Bit 4-7	Definition	How
0 0 0 0	Self-testing or unknown	Not used
0 0 0 1	Firmware update in progress	Not used
0 0 1 0	At least on errored I/O connection	–
0 0 1 1	No I/O connections established	–
0 1 0 0	Non-volatile configuration bad	Non-volatile memory detected error in OB
0 1 0 1	Major error - either bit 10 or 11 is true	Bit 10 or 11 is true
0 1 1 0	At least one I/O connection in run mode	–
0 1 1 1	At least one I/O connection established, all in idle mode	–
1 0 0 0 1 0 0 1	Reserved, shall be 0	–
1 0 1 0 to 1 1 1 1	Vendor specific	–

Supported Class Services

Service code	Service name	Description
01 hex	Get_Attribute_All	Read all attributes
0E hex	Get_Attribute_Single	Read one attribute

Supported Instance Services

Service code	Service name	Description
01 hex	Get_Attribute_All	Read all attributes
0E hex	Get_Attribute_Single	Read one attribute
10 hex	Set_Attribute_Single	Write one attribute

State Diagram for the Identity Object

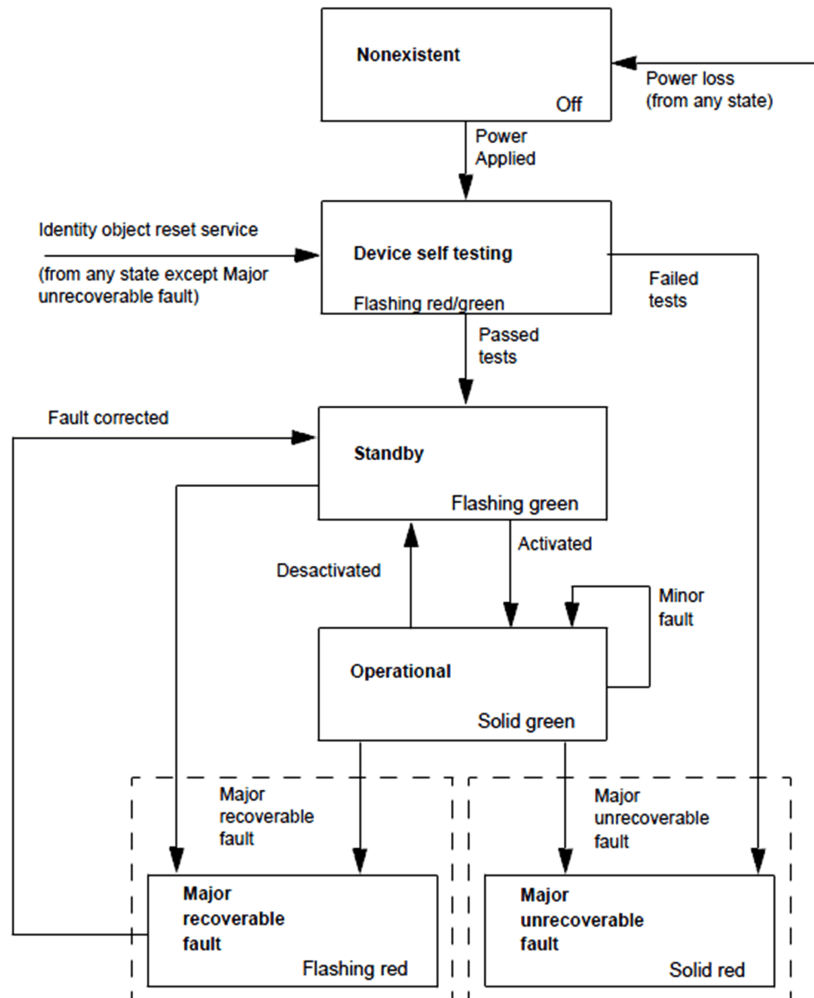

Message Router Object (02 hex)

Overview

The Message Router Object provides a messaging connection point through which a Client may address a service to any object class or instance residing in the physical device.

This is the element through which all the `Explicit messages` objects pass in order to be directed towards the truly destined objects.

Class Code

Hexadecimal	Decimal
02 hex	2

Class Attributes

Attribute ID	Access	Name	Data type	Value	Details
1	Get	Revision	UINT	X	Revision index of the class
2	Get	Max instances	UINT	1	1 defined instance
3	Get	Number of instances	UINT	1	–
4	Get	Optional attribute list	UINT	One of 1, 2, 3 and 100 to 119	–
5	Get	Optional service list	UINT	10	–
6	Get	Max ID of class attributes	UINT	7	–
7	Get	Max ID of instance attribute	UINT	119	–

Assembly Object (04 hex)

Overview

The Assembly Object binds attributes of multiple objects, which allows data to or from each object to be sent or received over a single connection.

Supported Class Attributes

Attribute ID	Access	Name	Data type	Value	Detail
1	Get	Revision	UINT	X	Revision index of the class
2	Get	Max instances	UINT	101	One defined instance
3	Get	Number of instances	UINT	2	–
4	Get	Number of attributes	UINT	1	–
6	Get	Max ID of class attributes	UINT	6	–
7	Get	Max ID of instance attribute	UINT	4	–

Supported Instances

Attribute ID	Access	Name	Data type	Value	Details
3	Get/Set	Data	ARRAY OF BYTE		
4	Get	Size	UINT		

Supported Instances for Altivar Process

Instance	Type	Name
100	AC Soft Starter output	Native Soft Starter Output
101	AC Soft Starter input	Native Soft Starter Input

Supported Class Services

Service code	Service Name	Description
0E hex	Get_Attribute_Single	Read one attribute

Supported Instance Services

Service Code	Service Name	Description
0E hex	Get_Attribute_Single	Read one attribute
10 hex	Set_Attribute_Single	Write one attribute

Output Instance Data Description

Instance	Byte	Bit 7	Bit 6	Bit 5	Bit 4	Bit 3	Bit 2	Bit 1	Bit 0
100	0-1	I/O Scanning word 1							
	2-3	I/O Scanning word 2							
	4-5	I/O Scanning word 3							
	6-7	I/O Scanning word 4							
	8-9	I/O Scanning word 5							
	10-11	I/O Scanning word 6							
101	0-1	Scanner Read word 1							
	2-3	Scanner Read word 2							
	4-5	Scanner Read word 3							
	6-7	Scanner Read word 4							
	8-9	Scanner Read word 5							
	10-11	Scanner Read word 6							

Connection Manager Object (06 hex)

Use this object for connection and connectionless communications, including establishing connections across multiple subnets.

Class Code

Hexadecimal	Decimal
06 hex	6

Class Attributes

Attribute ID	Access	Name	Need	Data type	Value	Details
1	Get	Revision	Opt.	UINT	X	Revision index of the class
2	Get	Max instances	Opt.	UINT	4	3 defined instance

Attributes of Instance 1 - Explicit Message Instance

Attribute	Access	Name	Need	Data type	Value	Details
1	Get	State	Req.	USINT	–	0: Non-existent 3: Established 5: Deferred Delete
2	Get	Instance_type	Req.	USINT	0	Explicit Message
3	Get	TransportClass_trigger	Req.	BYTE	83 hex	Class 3 server
4	Get	Produced_connection_id	Req.	UINT	10xxxxx011	xxxxxx = Node address
5	Get	Consumed_connection_id	Req.	UINT	10xxxxx100	xxxxxx = Node address
6	Get	Initial_comm_characteristics	Req.	BYTE	21 hex	Explicit messaging via Group 2
7	Get	Produced_connection_size	Req.	UINT	36	Produced data maximum size (in bytes)
8	Get	Consumed_connection_size	Req.	UINT	36	Consumed data maximum size (in bytes)
9	Get/Set	Expected_packet_rate	Req.	UINT	2500	2.5 sec. (TimeOut)
12	Get/Set	Watchdog_timeout_action	Req.	USINT	1 or 3	1: Auto-Delete 3: Deferred Delete (Default)
13	Get	Produced connection path length	Req.	UINT	0	Length of attribute 14 data
14	Get	Produced connection path	Req.	Array of UINT	Null	Not used
15	Get	Consumed connection path length	Req.	UINT	0	Length of attribute 16 data
16	Get	Consumed connection path	Req.	Array of UINT	Null	Not used

For details, refer to Ethernet/ specification for more information.

Supported Class Attributes

Attribute ID	Access	Name	Data type	Value	Details
1	Get	Revision	UINT	X	Revision index of the class
2	Get	Max Instances	UINT	1	1 defined instance
3	Get	Number of Instances	UINT	1	–
4	Get	Optional attribute list	STRUCT of	–	List of optional attribute numbers
6	Get	Max ID of class attributes	UINT	7	–
7	Get	Max ID of instance attributes	UINT	8	Attribute ID number of last class attribute

Supported Instance1 (Explicit) Attributes

Attribute ID	Access	Name	Data type	Details
1	Get	Open Requests	UINT	Number of forward open service requests received.
2	Get	Open Format Rejects	UINT	Number of forward open service requests which were rejected due to bad format.
3	Get	Open Resources Rejects	UINT	Number of forward open service requests which were rejected due to lack of resources.
4	Get	Open Other Rejects	UINT	Number of forward open service requests which were rejected for reasons other than bad format or lack of resources.
5	Get	Close Requests	UINT	Number of forward close service requests received.
6	Get	Close Format Requests	UINT	Number of forward close service requests which were rejected due to bad format.
7	Get	Close Other Requests	UINT	Number of forward close service requests which were rejected for reasons other than bad format.
8	Get	Connection Timeouts	UINT	Total number of connection timeouts that have occurred in connections controlled by this connection manager.

Supported Class Services

Service code	Service name	Description
01 hex	Get_Attribute_All	Read all attributes
0E hex	Get_Attribute_Single	Read one attribute

Supported Instance Services

Service code	Service name	Description
0E hex	Get_Attribute_Single	Read one attribute
10 hex	Set_Attribute_Single	Write one attribute
4E hex	Forward_Close	Closes a connection
54 hex	Forward_Open	Opens a connection, maximum data size is 511 bytes

Modbus Object (44 hex)

Overview

ODVA describes how to encapsulate a Modbus frame using a CIP object.

Modbus Class Object presents the ethernet IP interface with the Modbus encapsulation service defined in the ODVA.

Class Code

Hexadecimal	Decimal
44 hex	44

Application Object (70 hex to C7 hex) / Explicit Messaging

Overview

The whole parameter mapping of the soft starter be accessible through the Application objects.

Application Object Behavior

$$\text{Class} = ((\text{AdL} - 3000) / 200) + 70 \text{ hex}$$

$$\text{Instance} = 1$$

$$\text{Attribute} = (\text{AdL} \% 200) + 1$$

$$\text{AdL} = (\text{class} - 70\text{h}) * 200 + \text{attribute} - 1 + 3000$$

This rule allows the access to address under 20599. The other addresses are not accessible.

The soft starter parameters are grouped into classes.

- Each application class has only one instance.
- Each instance groups 200 parameters.
- Each attribute in an instance relates to a parameter.

For more information about the Communication Parameter Addresses, please refer to the [ATS490 Communication Parameter Addresses](#), page 12.

Supported Class Attributes

Attribute ID	Access	Name	Data type	Value	Details
1	Get	Revision	UINT	X	Revision index of the class
2	Get	Max Instances	UINT	1	One defined instance
3	Get	Number of Instances	UINT	1	–
6	Get	Max ID of class attributes	UINT	6	–
7	Get	Max ID of instance attribute	UINT	X	–

Supported Instance Attributes

Attribute ID	Access	Name	Data type	Details
1	Get/ Set	1st parameter of the block	UINT	Value returned by the soft starter at address xx
–	–	–	–	Value returned by the soft starter at address xx
X	Get/ Set	Last parameter of the block	UINT	Value returned by the soft starter at address xx

Supported Class Services

Service code	Service name	Description
0E hex	Get_Attribute_Single	Read one attribute

Supported Instance Services

Service code	Service name	Description
0E hex	Get_Attribute_Single	Read one attribute
10 hex	Set_Attribute_Single	Write one attribute

Port Object (F4 hex)

Overview

The port object represents the underlying interface of CIP which is EtherNet/IP.

Class Code

Hexadecimal	Decimal
F4 hex	244

Class Attributes

Attribute ID	Access	Name	Data type	Value	Details
1	Get	Revision	UINT	X	Revision index of the class
2	Get	Max instances	UINT	1	1 defined instance
3	Get	Number of instances	UINT	2	–
6	Get	Max ID of class	UINT	9	–
7	Get	Max ID of instance	UINT	11	–
8	Get	Entry port	UINT	2	–
9	Get	Port Instance Info	UINT	0x000-2 0004 0001 0001 0000 0000	–

TCP/IP Interface Object (F5 hex)

Overview

The TCP/IP Interface Object provides the mechanism to configure a device TCP/IP network interface. Examples of configurable items include the device IP Address, Network Mask, and Gateway Address.

Supported Class Attributes

Attribute ID	Access	Name	Data type	Value	Detail
1	Get	Revision	UINT	X	Revision index of the class
2	Get	Max instances	UINT	1	1 defined instance
3	Get	Number of instances	UINT	1	–
4	Get	Optional attribute list	UINT	0x00-11 0010 0009 0008 0004	–
6	Get	Max ID of class attributes	UINT	7	–
7	Get	Max ID of instance attribute	UINT	Embedded: 11	–

Supported Instance Attributes

Attribute ID	Access	Name	Data type	Detail
1	Get	Status	DWORD	0 = The interface configuration attribute has not been configured 1 = The interface configuration attribute contains valid configuration
2	Get	Configuration capability	DWORD	Bit 0 = 1 (TRUE) shall indicate that the device is capable of obtaining its network configuration via BOOTP Bit 1 = 1 (TRUE) shall indicate that the device is capable of resolving host names by querying a DNS server Bit 2 = 1 (TRUE) shall indicate that the device is capable of obtaining its network configuration via DHCP Bit 3 = 1 (TRUE) shall indicate that the device is capable of sending its host name in the DHCP request Bit 4 = 1 (TRUE) shall indicate that the Interface Configuration attribute is settable. Bit 5-31: reserved
3	Get/Set	Configuration control	DWORD	Bits 0-3 start-up configuration 0 = The device shall use the interface configuration values previously stored 1 = The device shall obtain its interface configuration values via BOOTP

Attribute ID	Access	Name	Data type	Detail
				2 = The device shall obtain its interface configuration values via DHCP upon start-up 3-15 = Reserved for future use Bit 4 = 1 (TRUE), the device shall resolve host names by querying a DNS server Bit 5-31: reserved
4	Get	Physical link object	STRUCT of UINT EPATH	Path size Path: Logical segments identifying the physical link object Example [20][F6][24][01]: [20] = 8-bit class segment type; [F6] = Ethernet link object class; [24] = 8-bit instance segment type; [01] = instance 1
5	Get/Set	Interface configuration	STRUCT of UDINT UDINT UDINT UDINT UDINT String	IP address (0: no address configured) Network mask (0: no network mask configured) Gateway address (0: no address configured) Name server address (0: no address configured) Name server address 2 (0: no address configured) Domain name
6	Get/Set	Host name	String	Read/write name of the soft starter
8	Get/Set	TTL value	USINT	TTL value for EtherNet/IP multicast packets
9	Get/Set	Mcast config	Struct Of.	IP multicast address configuration
		Alloc control	USINT	0 - Use default allocation algorithm to generate multicast addresses 1 - Multicast addresses shall be allocated according to the values in Num Mcast and Mcast Start Addr
		Reserved	USINT	Shall be 0
		Num Mcast	UINT	Number of multicast addresses to allocate for EtherNet/IP
		Mcast Start Addr	UDINT	Starting multicast address from which to begin allocation

Supported Class Services

Service code	Service name	Description
01 hex	Get_Attribute_All	Read all attributes
0E hex	Get_Attribute_Single	Read one attribute
10 hex	Set_Attribute_Single	Write one attribute

Supported Instance Services

Service code	Service name	Description
0E hex	Get_Attribute_Single	Read one attribute
10 hex	Set_Attribute_Single	Write one attribute
01 hex	Get_Attribute_All	–

TCP/IP Interface Behavior

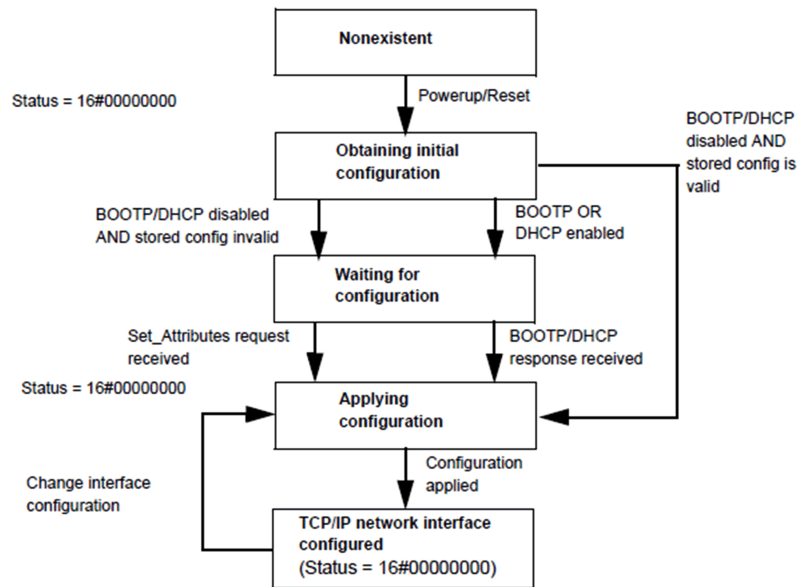

Ethernet Link Object (F6 hex)

Overview

The Ethernet Link Object maintains link-specific counters and status information for an IEEE 802.3 communications interface. Each device shall support exactly one instance of the Ethernet Link Object for each IEEE 802.3 communications interface on the module.

Class Attributes

Attribute ID	Access	Name	Data type	Value	Details
1	Get	Revision	UINT	X	Revision index of the class
2	Get	Max instances	UINT	2	Embedded: 1 defined instances
3	Get	Number of instances	UINT	Embedded: 1	–
6	Get	Max ID of class attributes	UINT	7	–
7	Get	Max ID of instance attribute	UINT	11	–

Supported Instance Attributes

Attribute ID	Access	Name	Data type	Detail
1	Get	Interface speed	UDINT	Interface speed currently in use
2	Get	Interface flags	DWORD	<p>Bit 0: Link status indicates whether the Ethernet 802.3 communications interface is connected to an active network. 0 indicates an inactive link; 1 indicates an active link</p> <p>Bit 1: Half/Full duplex indicates the duplex mode currently in use. 0 indicates that the interface is running half duplex; 1 indicates full duplex</p> <p>Bit 2-4: Negotiation status</p> <ul style="list-style-type: none"> • 0: Auto-negotiation in progress • 1: Auto-negotiation and speed detection not successful • 2: Auto negotiation not successful but detected speedduplex was defaulted • 3: Successfully negotiated speed and duplex • 4: Auto-negotiation not attempted. Forced speedand duplex <p>Bit 5: Manual setting require reset</p> <ul style="list-style-type: none"> • 0: Indicates that the interface can activate changes to link parameters (autonegotiate, duplex mode, interface speed) automatically • 1: Indicates that the device requires a reset service be issued to its identity object in order for the changes to take effect. <p>Bit 6: Local hardware error</p> <ul style="list-style-type: none"> • 0: Indicates that the interface detects no local hardware error

Attribute ID	Access	Name	Data type	Detail
				<ul style="list-style-type: none"> 1: Indicates that a local hardware error is detected. The meaning of this is product-specific Bit 7-31: Reserved shall be set to zero
3	Get	Physical address	USINT [6]	MAC layer address
4	Get	Interface counters	–	–
5	Get	Media counters	–	–
6	Get/Set	Interface control	–	Force auto negotiate, half full and speed
7	Get	Interface type	USINT	2
10	Get	Interface label	SHORT_STRING	Service code

Supported Class Services

Service code	Service name	Description
0E hex	Get_Attribute_Single	Read one attribute
01 hex	Get_Attribute_All	–

Supported Instance Services

Service code	Service name	Description
0E hex	Get_Attribute_Single	Read one attribute
10 hex	Set_Attribute_Single	Write one attribute
01 hex	Get_Attribute_All	–
4C hex	Get_And_Clear	Same than Get_Attribute_Single

Optional Attributes List

Service code	Access	Name	Data Type	Description
08 hex	Get	Interface State	USINT	Current State
09 hex	Get/Set	Admin State	USINT	Administrative State: Enable or Disable

Diagnostics and Troubleshooting

What's in This Part

Fieldbus Status LEDs	111
Configuring Communication Error Response	113
Communication troubleshooting	114
Control-Signal Diagnostics	115
Warning Messages.....	116
Communication error codes	119

Fieldbus Status LEDs

LED Description

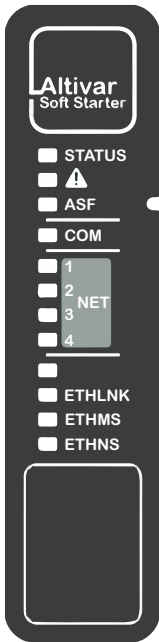

LED	Color & status	Description
STATUS	OFF	Indicates that the soft starter is not ready to start
	Green flashing	Indicates that the soft starter is not running, ready to start
	Green blinking	Indicates that the soft starter is in transitory status (acceleration, deceleration, and so on)
	Green on	Indicates that the soft starter is running
	Yellow on	Indicates that the soft starter localization is in progress
Warning/Error	Red flashing	Indicates that the soft starter has detected a warning
	Red on	Indicates that the soft starter has detected an error
ASF	OFF	Indicates Safety Function STO is not active.
	Yellow on	Indicates Safety Function STO is triggered.
COM	Yellow flashing	Indicates embedded Modbus serial activity via Modbus VP12S port
ETHLNK	Indicates port activity	
	OFF	No link
	Blinking Green/Yellow	Power on testing
	Green ON	Link established at 100 Mbit/s
	Yellow ON	Link established at 10 Mbit/s
	Blinking Green	Fieldbus activity at 100 Mbit/s
	Blinking Yellow	Fieldbus activity at 10 Mbit/s

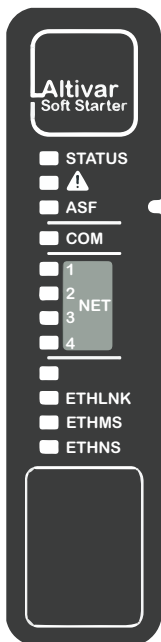

LED	Color & status	Description
ETHMS	Indicates network status.	
	OFF	No power is supplied to the device
	Blinking Green/Red	Power on testing
	Green ON	The device is operating correctly.
	Blinking Green	Device has not been configured.
	Blinking red	The device has detected a recoverable minor detected error.
	Red ON	The device has detected a non-recoverable major detected error
ETHNS	Indicates module status	
	OFF	The device does not have an IP address or powered off
	Blinking Green/Red	Power on testing
	Green ON	A connection is established to control the command word
	Blinking Green	Device has a valid IP, but no command word connection
	Red ON	Duplicated IP
	Blinking Red	An established connection to control the command word is closed or timed out

LED Behavior

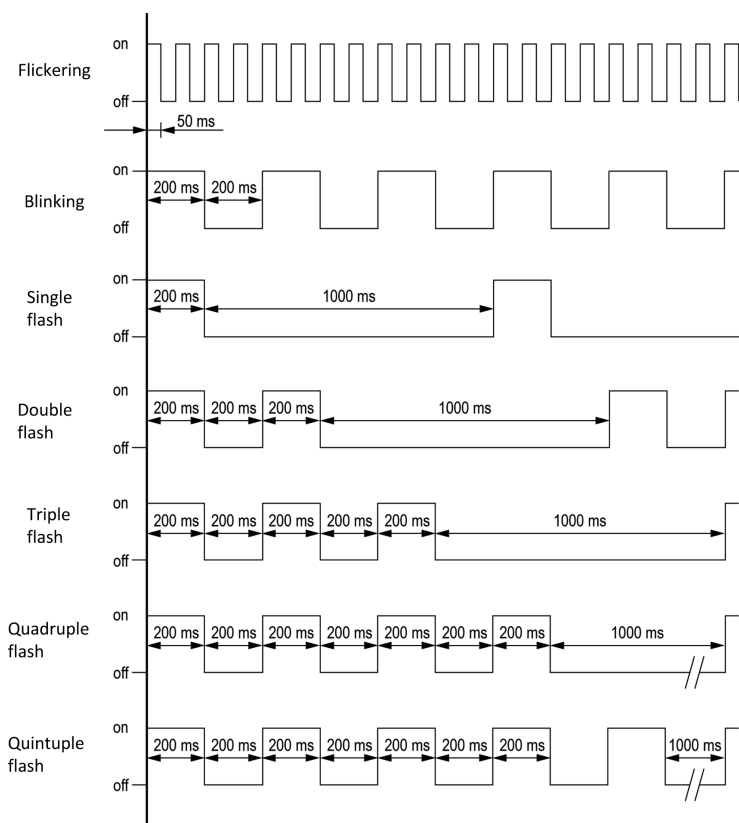

Configuring Communication Error Response

⚠ WARNING
<p>LOSS OF CONTROL</p> <p>Perform a comprehensive commissioning test to verify that communication monitoring properly detects communication interruptions.</p> <p>Failure to follow these instructions can result in death, serious injury, or equipment damage.</p>

The timeout of Communication Error Response can be set via **[Ethernet Timeout]** parameter.

The response of the soft starter in the event of a communication interruption can be configured through **[Eth Error Response]** in the **[Communication]** menu of the graphic display terminal.

The values of the **[Eth Error Response]** parameter, which triggers a soft starter detected error **[Embd Eth Com Interrupt]** **ETHF** are:

Value	Meaning
[Freewheel Stop] YES	Motor triggers in error and is stopped in freewheel. Factory setting
[Deceleration] DEC	Motor is stopped in deceleration and triggers in error at the end of stop.
[Braking] BRK	Motor is stopped in dynamic braking and triggers in error at the end of stop.

The values of the **[Eth Error Response]** **ETHL** parameter which does not trigger a detected error are:

Value	Meaning
[Ignore] NO	Detected error ignored.
[Configured Stop] STT	Motor is stopped according to [Type of stop] STT parameter.

⚠ WARNING
<p>LOSS OF CONTROL</p> <p>If this parameter is set to [Ignore], Ethernet communication monitoring is disabled.</p> <ul style="list-style-type: none"> • Only use this setting after a thorough risk assessment in compliance with all regulations and standards that apply to the device and to the application. • Only use this setting for tests during commissioning. • Verify that communication monitoring has been re-enabled before completing the commissioning procedure and performing the final commissioning test. <p>Failure to follow these instructions can result in death, serious injury, or equipment damage.</p>

Communication troubleshooting

Checking Connections

If the product cannot be addressed using the fieldbus, verify that:

- The soft starter and the PLC are supplied.
- The wires are correctly connected to the port (if possible).
- The wiring of the all devices on the network is consistent.

Comportment when an communication error occurs

Send a word with **[Cmd Register]** to validate the **[Cmd channel 1]** or the **[Cmd channel 2]** to activate this channel.

If a communication interruption appears:

1. **[Eth embd : Time-out]** is activated.
2. After the end of the delay of **[Eth embd : Time-out]**, the motor is stopped following the value set on **[Eth Error Response]**.
3. An error **[Embd Eth Com Interrupt] ETHF** is triggered, and depending of **[Auto Fault Reset]**, **[R1 Assignment]** is deactivated (if set to **[Operating State Fault]**) following the value set on **[Eth Error Response]**.

Control-Signal Diagnostics

On the display terminal, the **[Communication]**– menu can be used to display control-signal diagnostic information between the soft starter and the controller:

- Active command channel **[Command Channel]**.
- Value of the control word **[Cmd Register]** from the active command channel **[Command Channel]**.
- Value of the operating state word **[Status Register]**.
- Specific data for all available fieldbuses are in dedicated submenus.

Warning Messages

List of Available Warning Messages

Any warning that is triggered and assigned to a warning group, will be :

- signaled by the LED of the soft starter;
- signaled by the icon  on the graphic display terminal;
- logged in the warning history.

Access paths to assign to a warning group:

- **[Diagnostics] → [Warnings]**
- **[Complete settings] → [Error/Warning handling] → [Warning groups config]**

By default the following warnings are assigned to the **[Warn grp 1 definition]**:

- **[PumpCycle warning]**
- **[Low Battery Warn]**
- **[No Battery Warn]**
- **[Invalid RTC Warn]**
- **[Nameplate Mismatch]**
- **[Mains Loss Warn]**
- **[Output Phase Loss]**
- **[Static Port/Serv Warn]**
- **[Serv. Access Auth.]**
- **[ByPass Ov.Curr Warn]**

Setting	Code	Description
[PumpCycle warning]	PCPA	Pump cycle warning.
[Anti-Jam Warning]	JAMA	Anti-Jam warning.
[Device Therm Warn]	THA	Device thermal state warning.
[Therm Junction Warn]	TJA	Thermal junction warning.
[Fan Counter Warning]	FCTA	Fan counter warning.
[Fan Feedback Warning]	FFDA	Fan feedback warning.
[Ext. Error Warning]	EFA	External error warning.
[Undervoltage Warning]	USA	Undervoltage warning.
[Forced Run]	ERN	Device in forced run.
[Process Undld Warning]	ULA	Process underload warning.
[Process Overload Warning]	OLA	Process overload warning.
[Dev Thermal reached]	TAD	Device thermal threshold reached.
[Ethernet Internal Warning]	INWM	Ethernet Internal warning.
[AI1 Th Warning]	TP1A	AI1 thermal sensor warning.
[Motor Overload Warn]	OLMA	Motor overload warning.
[Low Battery Warn]	RBLA	Soft starter Low Battery warning.
[No Battery Warn]	RBNA	Soft starter Battery not detected warning.
[Invalid RTC Warn]	RTCA	Invalid RTC warning
[Bypass Warn]	BPA	Bypass warning
[Modbus Com Warn]	SLLA	Modbus comm interruption warning.
[Fieldbus Com Warn]	CLLA	Fieldbus comm interruption warning.
[CANopen Com Warn]	COLA	CANOpen comm interruption warning.
[Inhibited Errors Warn]	INH	Inhibited errors warning.
[Temp Sens AI1 Warn]	TS1A	Temperature sensor AI1 warning.
[Mains Loss Warn]	PHF	Mains Loss warning.
[Output Phase Loss]	OPF	Output Phase Loss warning.
[Bypass Cont Excess]	BPCA	Recommended bypass contactor cycles exceeded , the bypass contactor cycles exceeded 90% of total service life.
[Overvoltage Warn]	OSA	Overvoltage warning.
[Volt Unbalance Warn]	ULBA	Mains unbalance warning.
[Voltage Sag Warn]	SAGA	Voltage sag detection warning.
[Voltage Inconsistent]	MTVA	Motor voltage vs. Mains inconsistency warn.
[Nameplate Mismatch]	MNIA	Nameplate Inconsistency Alarm.
[Curr Unbalance Warn]	ILBA	Current unbalance warning.
[Mains Freq Warn]	FRQA	Mains frequency warning.
[Config Recover Warn]	CBRA	Configuration recovery warning.
[Sys. Log. Warning]	SLGA	System Log Warning , application and log limits is almost reached (or reached), logs must be downloaded.

Setting	Code	Description
[Serv. Access Auth.]	SMSA	After-Services Access Authorized , After Sales Services tab enabled.
[FDR Set Serv Warn]	FDSA	FDR setting service warning.
[IP Set Serv Warn]	IPSA	IP setting service warning.
[RSTP Set Serv Warn]	RSSA	RSTP setting service warning.
[Static Port/Serv Warn]	PSSA	Static port/service warning.
[ByPass Ov.Curr Warn]	BYFA	Bypass Contactor Overcurrent Warning.

Communication error codes



What's in This Chapter

[Invalid Configuration] CFI	120
[Conf Transfer Error] CFI2	120
[External Error] EPF1	120
[Embd Eth Com Interrupt] ETHF	121
[FDR 1 Error] FDR1	121
[Internal Error 22] INFM	121

In this chapter, a list of some of the errors that can be triggered by the communication-related soft starter can be found, for a full description please refer to the user manual.



[Invalid Configuration] CFI

Invalid configuration

 Probable Cause	Inconsistent, invalid, unauthorized or out-of-bound value written to a parameter via a fieldbus or communication link. The written value is rejected, the previous one is kept and this error is triggered.
 Remedy	<ul style="list-style-type: none"> • Writing a correct value on any parameters via communication or fieldbus link. • Writing a correct value on any parameters via any HMI (display terminal, SoMove...). • Reset to factory settings, new configuration transfer or configuration restoration.
 Clearing the Error Code	This detected error is cleared as soon as its cause has been removed.



[Conf Transfer Error] CFI2

Configuration transfer error

 Probable Cause	<ul style="list-style-type: none"> • The configuration transfer to the soft starter was not successful or interrupted. • The configuration loaded is not compatible with the soft starter.
 Remedy	<ul style="list-style-type: none"> • Verify the configuration loaded previously • Load a compatible configuration • Use a PC software commissioning tool to transfer a compatible configuration • Perform a factory setting <p>NOTE: When this error is triggered, the current security configuration is kept valid and applied.</p>
 Clearing the Error Code	This detected error is cleared as soon as its cause has been removed.



[External Error] EPF1

External detected error

 Probable Cause	<ul style="list-style-type: none"> • Error raised based on [Ext Error assign] configuration via [DI•] or [CD••]. • Duplicate or invalid IP address.
 Remedy	Remove the cause of the external error.
 Clearing the Error Code	This detected error can be cleared manually with the [Fault Reset Assign] parameter after its cause has been removed.



[Embd Eth Com Interrupt] ETHE

Embedded Ethernet communication interruption

	Probable Cause	Communication interruption on the Modbus TCP/Ethernet IP bus.
	Remedy	<ul style="list-style-type: none"> • Verify the communication settings on the devices (Soft Starter, PLC, switches, repeater...). • Check for duplicate communication addresses. • Verify the environment (electromagnetic compatibility). • Verify the fieldbus wiring (continuity, cable type, grounding, and shielding) • Verify the time out. • Verify the Ethernet Client state. • Verify the Ethernet network load. • Refer to the Ethernet user manual. • Contact your local Schneider Electric representative. <p>NOTE: it is possible to check the status of ETHE through the communication with his register (ADL: 7136).</p>
	Clearing the Error Code	This detected error can be cleared with the [Auto Fault Reset] or manually with the [Fault Reset Assign] parameter after its cause has been removed.



[FDR 1 Error] FDR1

FDR Eth embedded error

	Probable Cause	<ul style="list-style-type: none"> • Communication interruption between the soft starter and the PLC during initialization. • Configuration file incompatible, empty or corrupted. • Soft starter rating not consistent with the configuration file.
	Remedy	<ul style="list-style-type: none"> • Verify the soft starter and PLC connection and communication. • Verify the communication workload. • Check that the configuration file is suitable for the installation. • Restart the transfer of configuration file from soft starter to PLC.
	Clearing the Error Code	This detected error can be cleared with the [Auto Fault Reset] or manually with the [Fault Reset Assign] parameter after its cause has been removed.

[Internal Error 22] INFM

Internal error 22 (Embedded Ethernet)

	Probable Cause	<ul style="list-style-type: none"> • An error on the embedded Ethernet adapter has been detected. • Unstability of external 24 Vdc supply.
	Remedy	<ul style="list-style-type: none"> • Verify the connection to the Ethernet port. • Verify the 24 Vdc stability. • Contact your local Schneider Electric representative.
	Clearing the Error Code	This detected error requires a power reset of the device after its cause has been removed.

ATS490 integration under M580 (in control expert) using DTM

What's in This Part

Introduction.....	123
Configuration of the M580	124
Soft Starter Configuration with Control Expert.....	125
Establish the communication between M580 and Soft starter.....	130

Introduction

Overview

The following figure shows the basic configuration to control the soft starter with a M580 PAC.



Configuration of the M580

Ethernet Port Configuration

From the project browser, open the EtherNet/IP port configuration by double-clicking the Ethernet port and configure Ethernet settings.

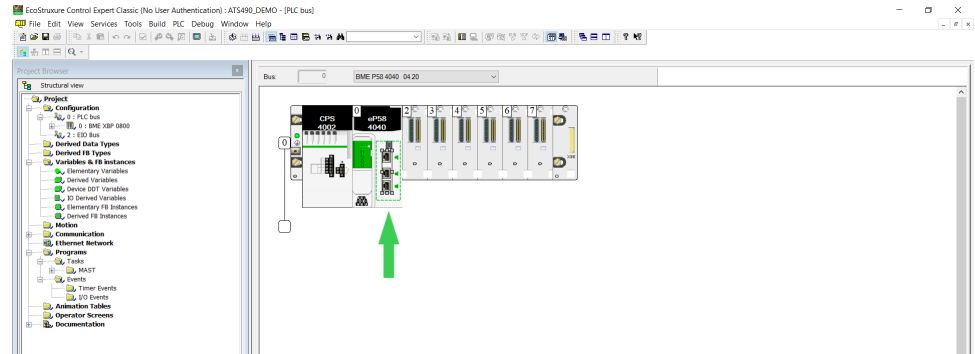

NOTE: For more details, refer to the M580 manual.

Soft Starter Configuration with Control Expert

Overview

In the following example, with a product out of the box, the soft starter configuration must be done as follows in-order to establish communication between the soft starter and the M580.

The soft starter configuration is done using the Control Expert software and by downloading the DTM, page 13.

NOTE: The below example do not consider the cybersecurity configuration. The below example can be done in Ethernet IP or in Modbus TCP.

Add ATS490 to the Project

After installing the DTM library on your PC, update Hardware catalog or restart the Control Expert to add the DTM to the Control Expert libraries.

In the DTM Browser, right-click the Ethernet Controller and Scroll to **Add**, as shown in the following figure:

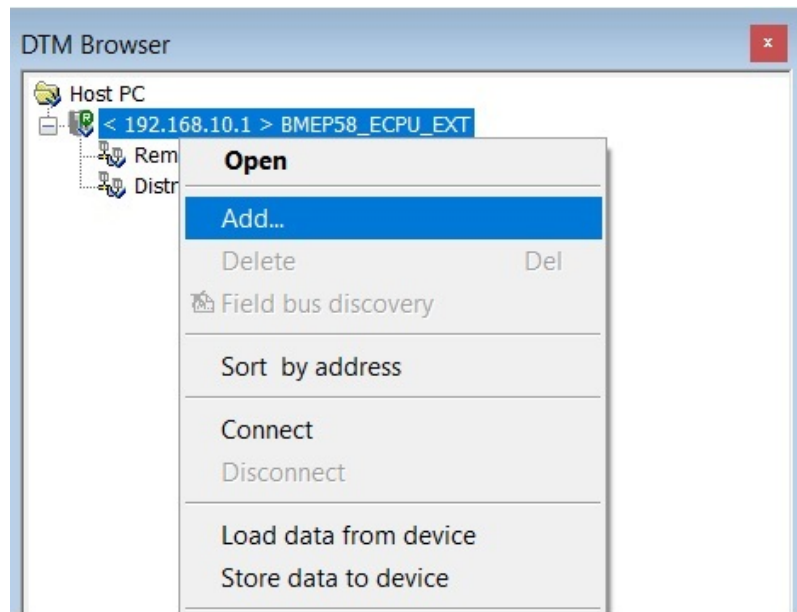

Select the protocol:

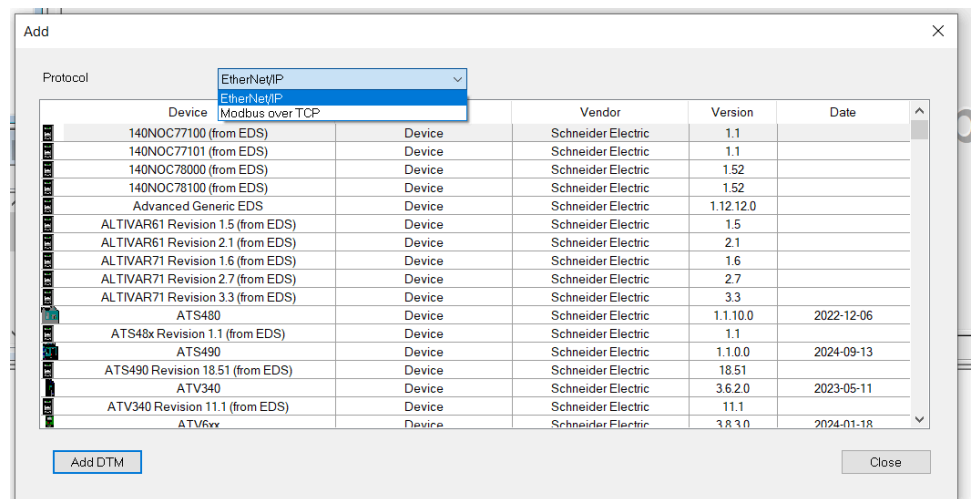

Select the soft starter from the list and click the **Add DTM** button to see the association between the Ethernet Controller and the Soft starter in the DTM browser:

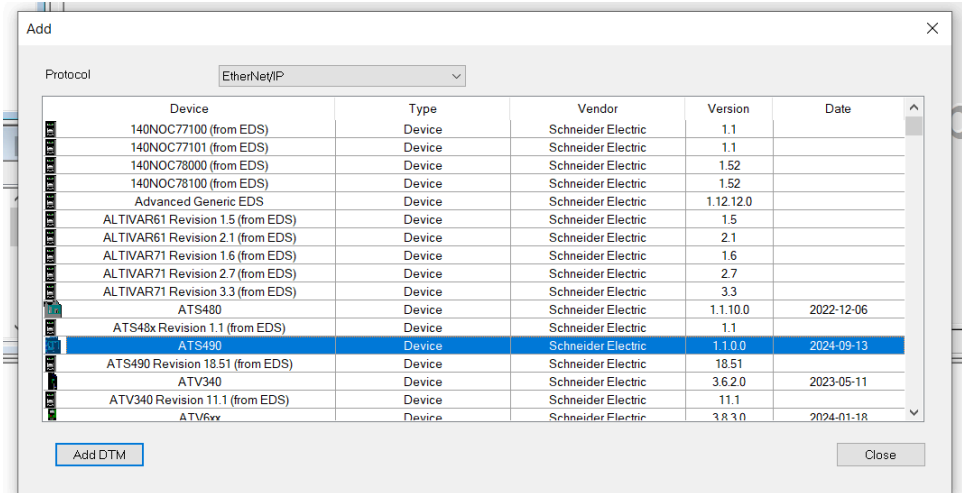

Create an unique Alias name (using similar devices that use the same DTM can result in duplicate module names). In this example, type in the **Name: "ATS490"**. The alias name is used by default as device name for DHCP service and FDR service.

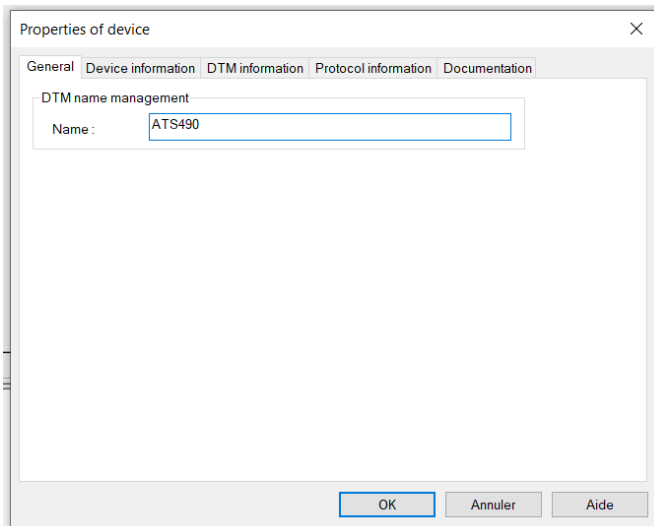

In the next steps, we will prepare the configuration of the soft starter in offline mode before connect it to the M580.

Create ATS490 topology

Double click on the soft starter DTM.

Select the product reference of the product and option module if exist.

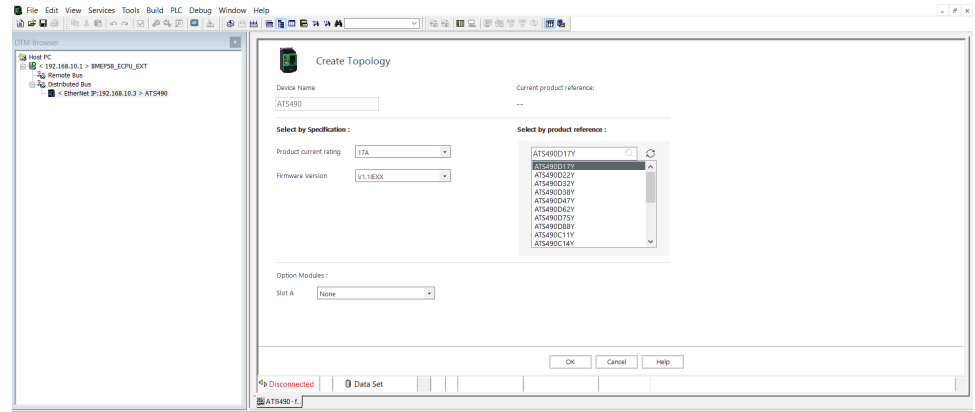

Set the command configuration

To control the soft starter with an Ethernet controller, select Ethernet as active command.

Go to:

- **Parameters List** tab
- Click on **Command channel** part

Result: Following window is displayed:

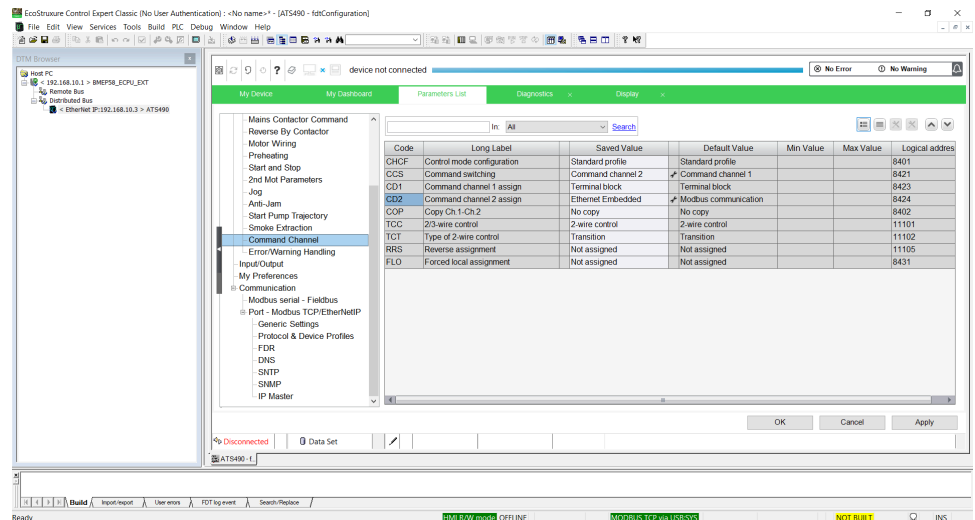

Check the ethernet configuration

In our example, [DHCP] DHCP is selected under this menu:

Communication, Port - Modbus TCP/EtherNetIP, Generic Settings.

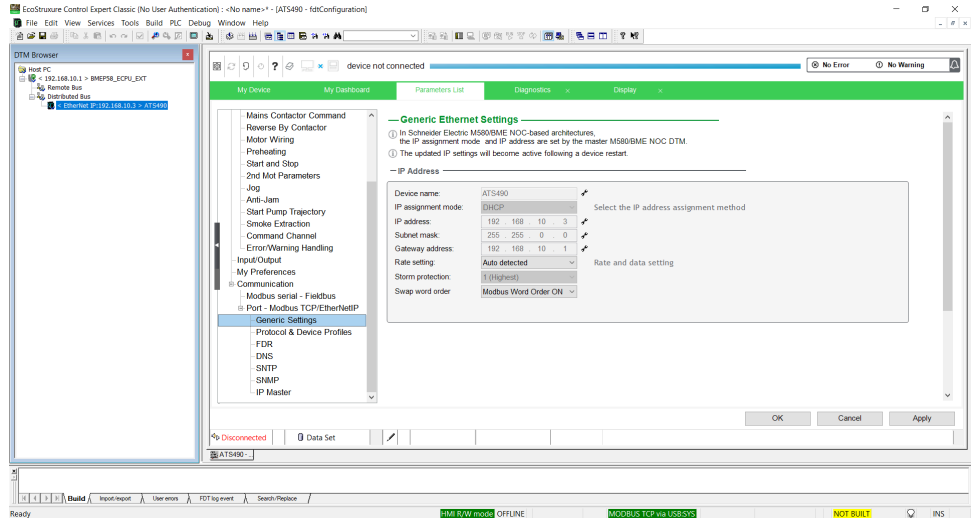

NOTE: FDR is enable by default. Refer to Fast Device Replacement, page 34 for more details.

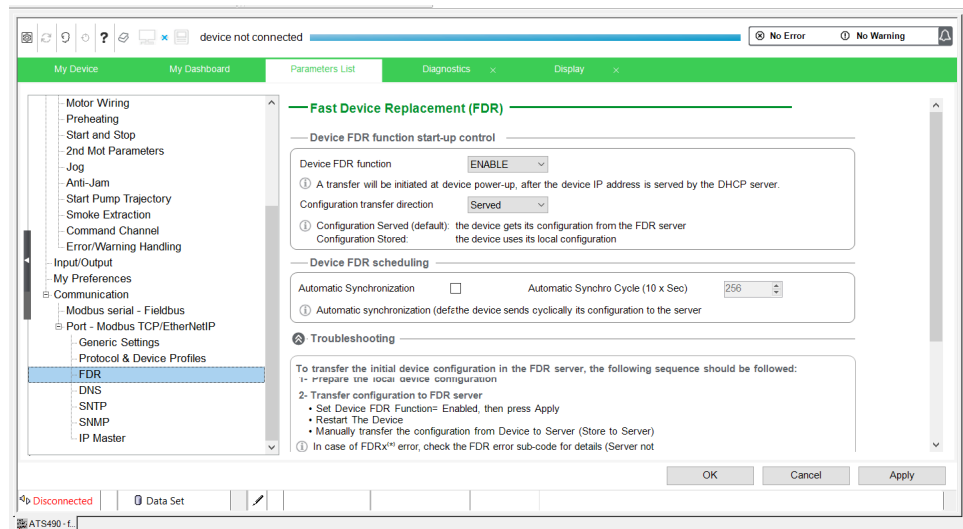

I/O scanner setting

To configure the I/O scanner, go to:

Communication, Port - Modbus TCP/EtherNetIP, Protocol & Device Profiles.

Perform the configuration according to the device I/O profile used in the application.

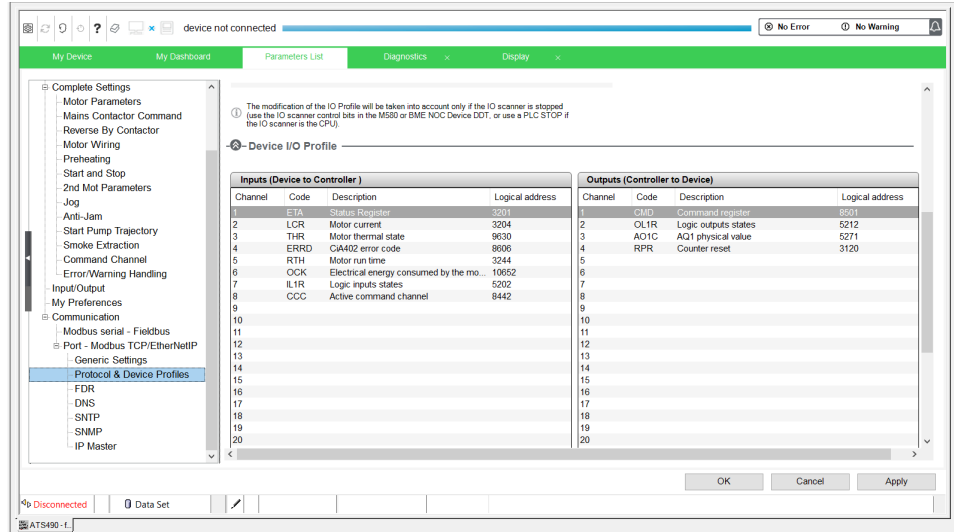

Establish the communication between M580 and Soft starter

Transfer project to M580

After build the program, on control expert, connect and transfer project to the M580:

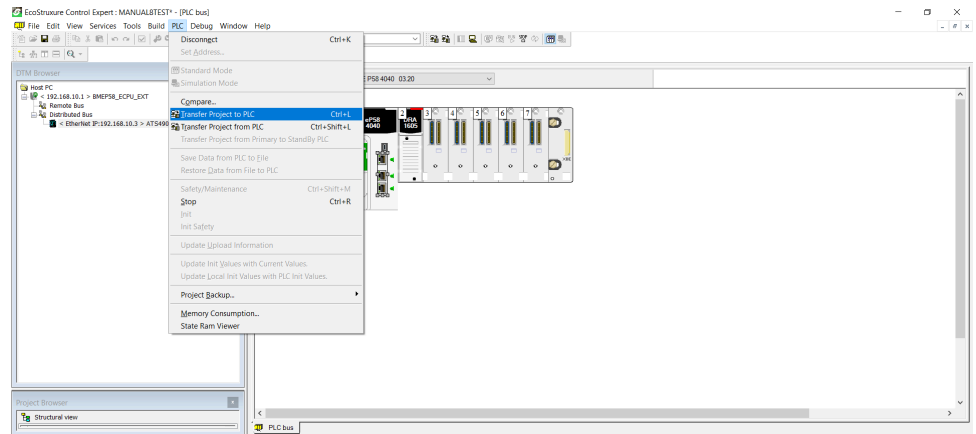

Assign a device name to the soft starter

The DHCP server (M580) will automatic assign the IP address to the soft starter through the valid device name.

Via SoMove or a display terminal, assign the device name to the soft starter.

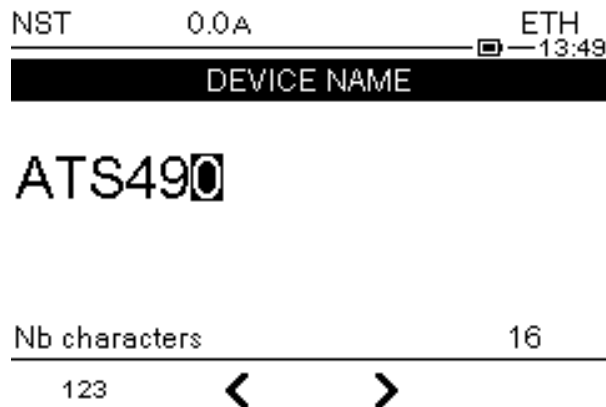

Transfer configuration to the soft starter

1. Configure channel properties of the M580. To make the connection, choose a Source IP Address (PC) that is in the same network as the controller and the soft starter network.

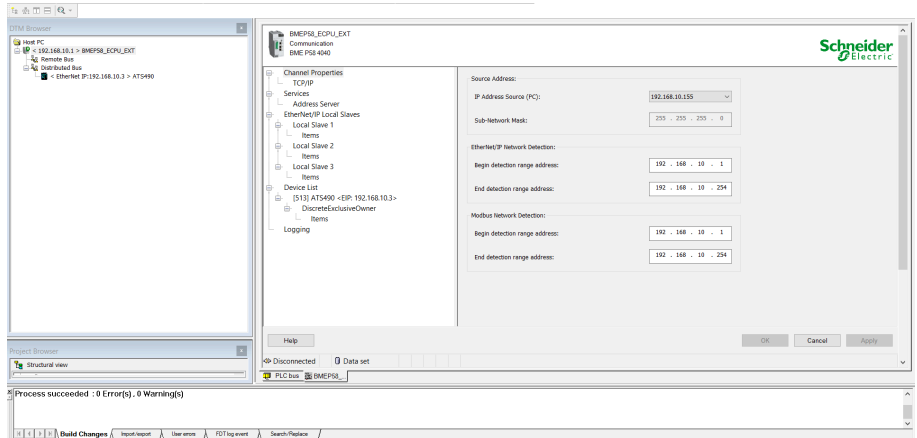

2. Connect to the soft starter by right-click the name of the soft starter and scroll to **Connect**.

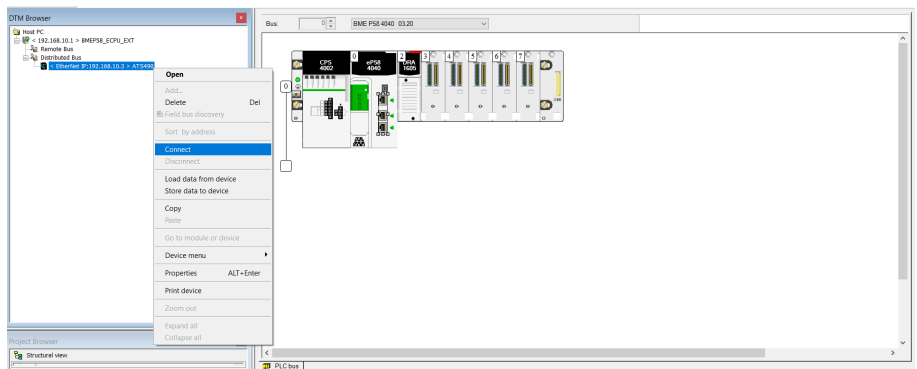

3. Transfer configuration to the soft starter by right-click the name of the soft starter and scroll **Store data to device**.

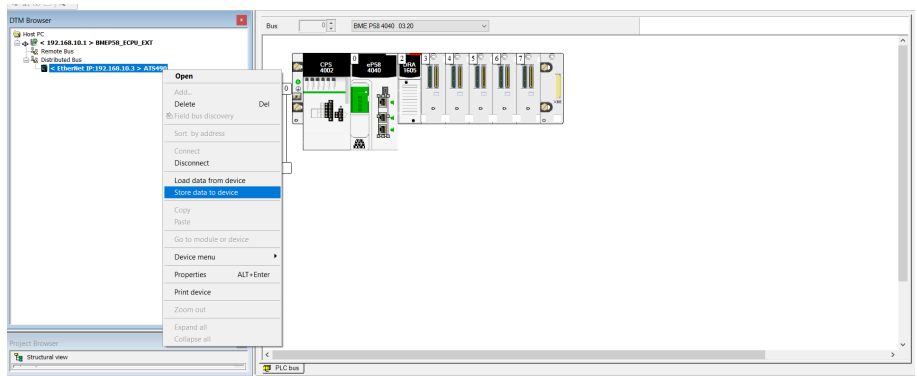

4. After transfer the configuration to the soft starter, the project must be build and transfer to the controller.

Check the connection between the M580 and the soft starter

The DTM will generate **Device DDT**.

In control expert, go to **Elementary variables** and select **Device DDT**.

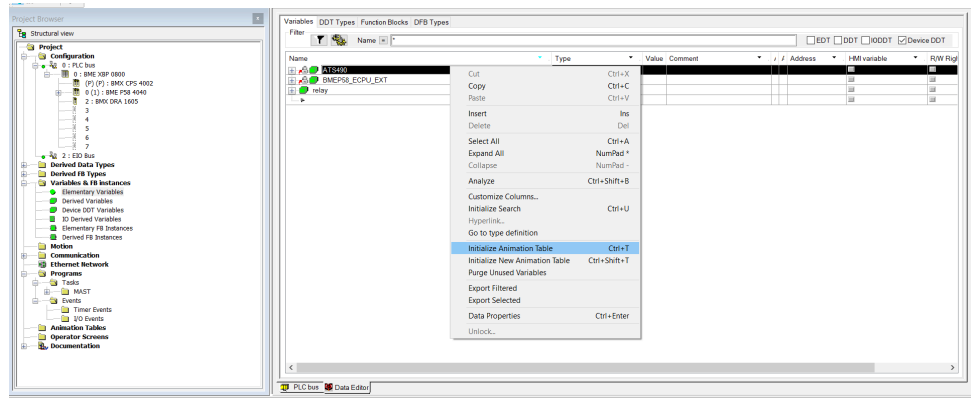

Looking for **ATS490** in the list and add it to the **Animation Table**.

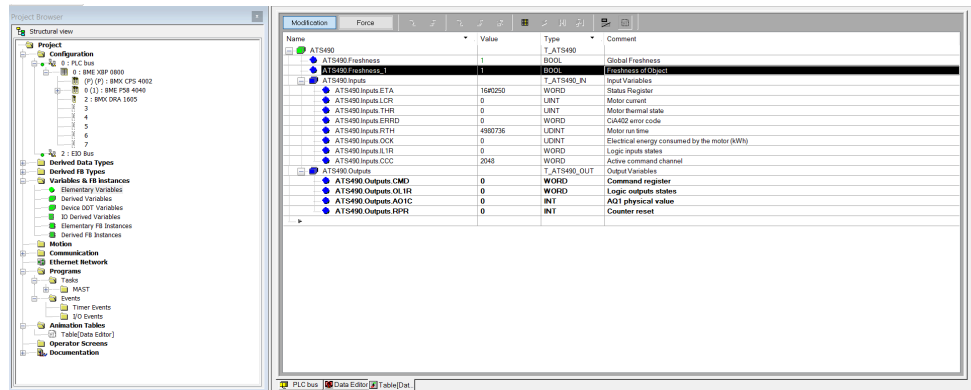

Check the freshness (global and freshness of object). It must be at 1.

ATS490 integration under Allen Bradley Rockwell using EDS

What's in This Part

Introduction.....	134
Soft Starter Configuration with SoMove.....	135
Allen-Bradley Control Logix Configuration	138

Introduction

Overview

In the following example:

- Soft Starter is connected to an Allen-Bradley Control Logix.
- Communication protocol used is EtherNet/IP with assemblies 100/101.
- Soft Starter can be controlled through the Allen-Bradley Control Logix.

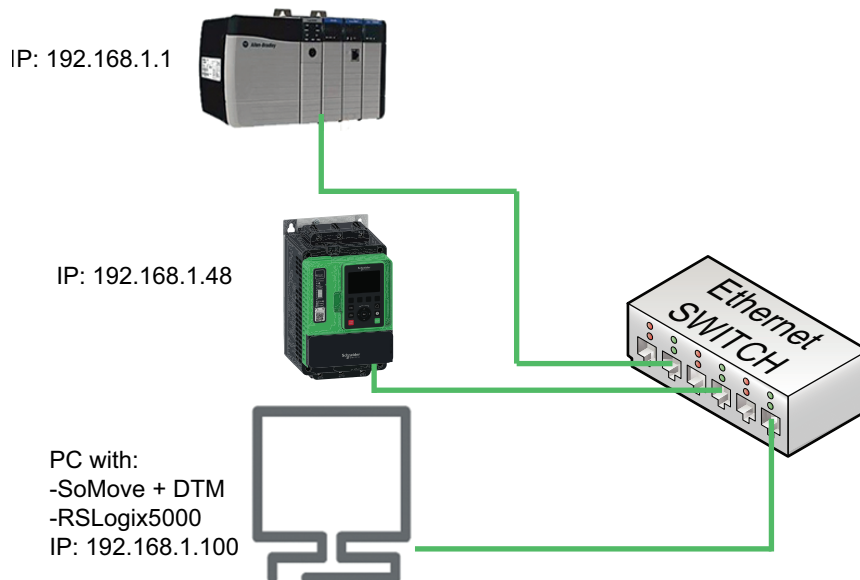

Soft Starter Configuration with SoMove

Overview

In the following example, the soft starter configuration must be done as follows in order to establish communication between the soft starter and the PLC.

The soft starter configuration is done using the soft starter DTM with SoMove software.

Factory Settings

Before configuring the soft starter, make sure that you reset the soft starter to factory settings.

- On the menu bar, select **Device > Factory Settings > Execute**.

Result: Following window is displayed:

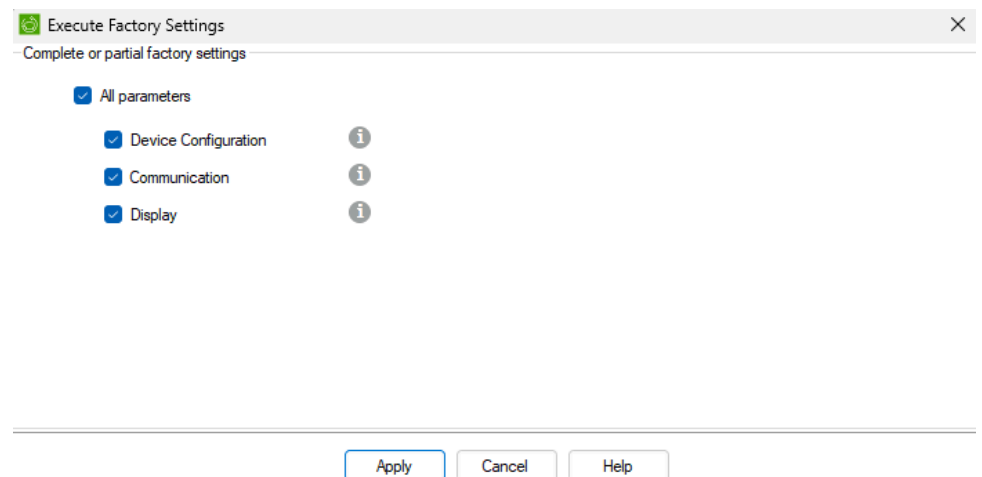

- Select **All parameters**, then click on **Apply**

Result: The factory setting is applied to the soft starter configuration

Command Configuration

To control the soft starter with an Ethernet client, select Ethernet as active command.

Go to:

- **Parameters List** tab
- Click on **Command channel** part

Result: Following window is displayed:

Code	Long Label	Saved Value	Default Value	Min Value	Max Value	Logical address
CHCF	Control mode configuration	Standard profile	Standard profile			8401
CCS	Command switching	Command channel 2	Command channel 1			8421
CD1	Command channel 1 assign	Terminal block	Terminal block			8423
CD2	Command channel 2 assign	Ethernet Embedded	Modbus communication			8424
COP	Copy Ch. 1-Ch. 2	No copy	No copy			8402
TCC	2/3-wire control	2-wire control	2-wire control			11101
TCT	Type of 2-wire control	Transition	Transition			11102
RRS	Reverse assignment	Not assigned	Not assigned			11105
FLO	Forced local assignment	Not assigned	Not assigned			8431

Ethernet Configuration

To set the Ethernet address of the soft starter, go to:

Communication, Port - Modbus TCP/EtherNetIP, Generic Settings.

Perform the configuration according to the network settings. In this example, the soft starter is configured with following data:

- A device name
- Fixed IP
- IP address: 192.168.1.48
- Mask: 255.255.255.0

Generic Ethernet Settings

In Schneider Electric M580/BME NOC-based architectures, the IP assignment mode and IP address are set by the master M580/BME NOC DTM.

The updated IP settings will become active following a device restart.

— IP Address —

Device name:	ATS490	Select the IP address assignment method
IP assignment mode:	Fixed address	
IP address:	192 . 168 . 1 . 48	
Subnet mask:	255 . 255 . 255 . 0	
Gateway address:	0 . 0 . 0 . 0	
Rate setting:	Auto detected	Rate and data setting
Storm protection:	1 (highest)	
Swap word order	Modbus Word Order ON	

I/O Scanner Configuration

To configure the assemblies used for Ethernet/IP fieldbus, go to:

Communication, Port - Modbus TCP/EtherNetIP, Protocol & Device Profiles.

Perform the configuration according to the device I/O profile used in the application.

Result: Following window is displayed:

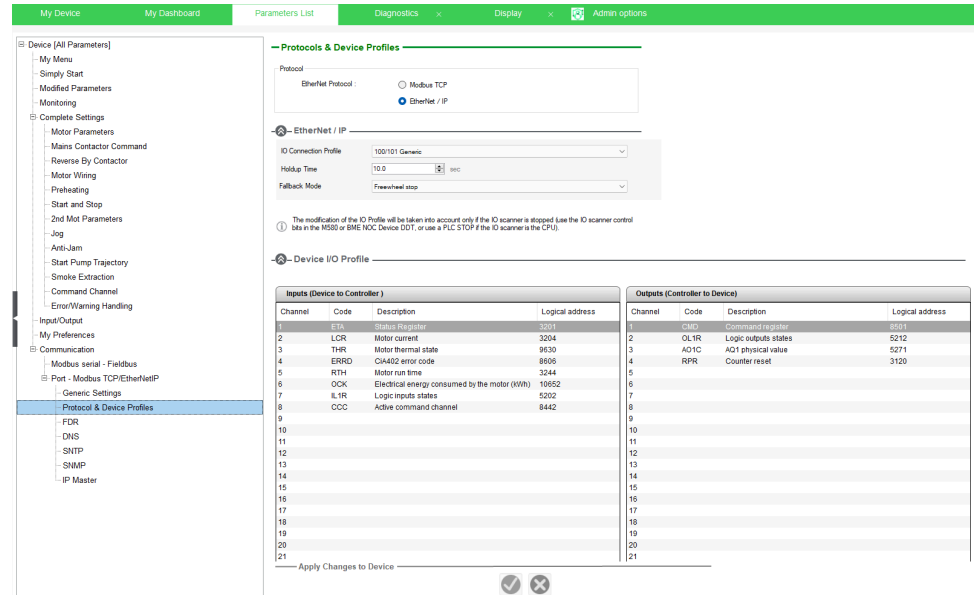

NOTE:

Click on **Apply** button if needed to validate the configuration then restart the soft starter.

Allen-Bradley Control Logix Configuration

Overview

In the following example, the Allen-Bradley Control Logix is configured to use both types of exchanges available through Ethernet/IP fieldbus:

- Implicit data exchange
- Explicit data exchange

Adding soft starter

By downloading and installing the EDS file, it is possible to import the configuration data.

Make a right click on Ethernet and click on **New Module**.

Result: Following window is displayed:

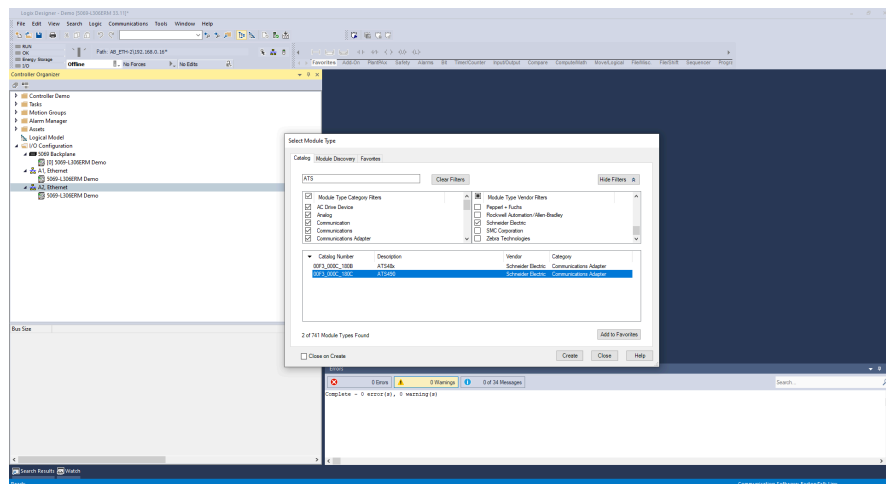

Select **ATS490** and enter the following information:

- Name: **ATS490**.
- IP address: **192.168.1.48**.
- Change the **Native Profile** type to **INT**.

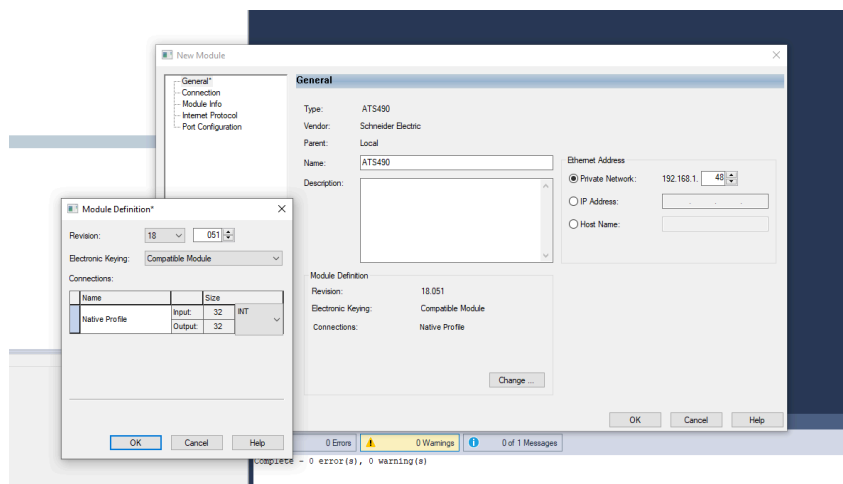

Build the project, then connect and download the project.

Implicit Data Exchange

It is possible to verify that implicit data exchange is working by clicking on **Controller Tags**.

The values are refreshed and soft starter can be controlled

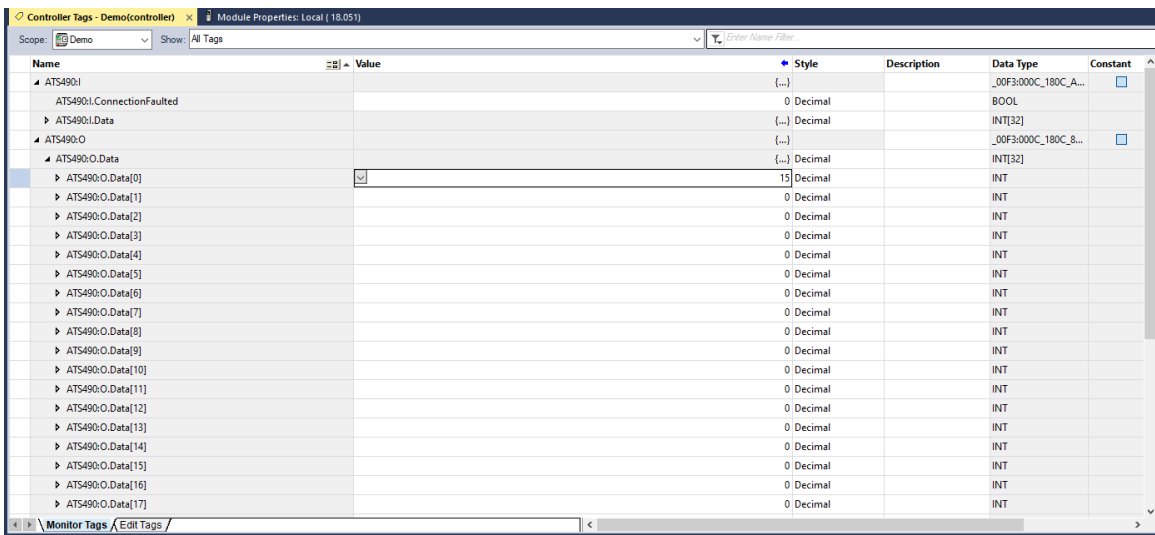
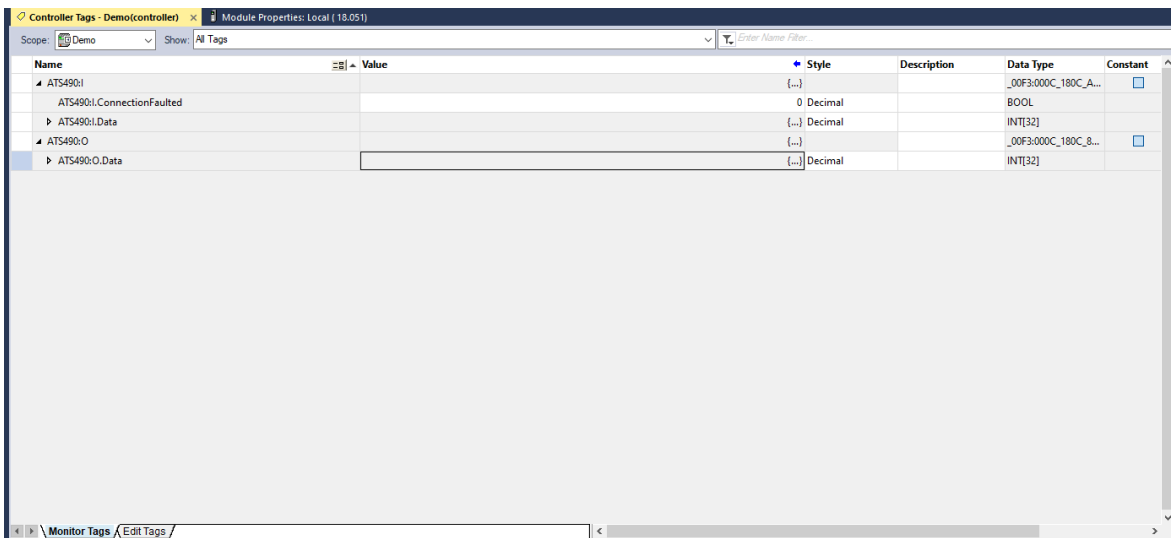

Explicit Data Exchange

To configure the explicit data exchange, insert a *MSG* block inside a routine.

The following procedure describe how to read and write the value of parameter **[Acceleration]** ACC.

- Create a Routine and do the following program:

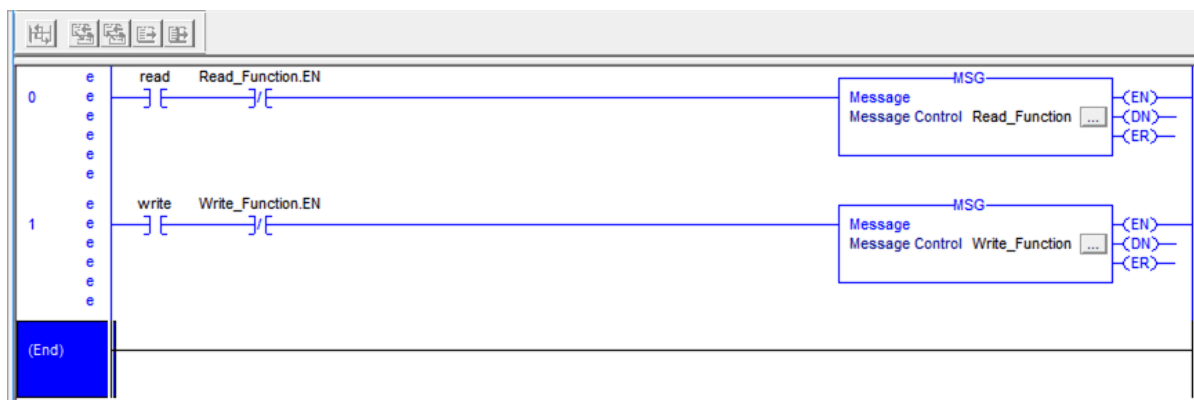

The *Read* Boolean will trigger the *Read_Function* to read the **[Acceleration]** ACC parameter.

The *Write* Boolean will trigger the *Write_Function* to write the **[Acceleration]** ACC parameter.

Configuration of *Read_Function*:

- Click on the "..." button of *Read_Function* block and do the following configuration:

On the Configuration tab:

- Enter the CIP address of **[Acceleration]** ACC parameter: 16#8E/01/3D.
- The value of the parameter will be stored in the variable *Read_ACC*.

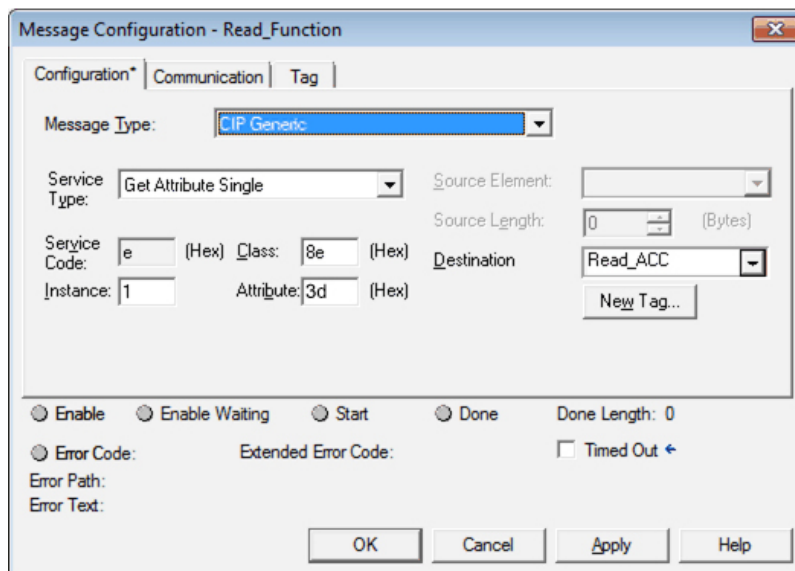

On the Communication tab:

- Configure the Path of the device by clicking on **Browse** button.

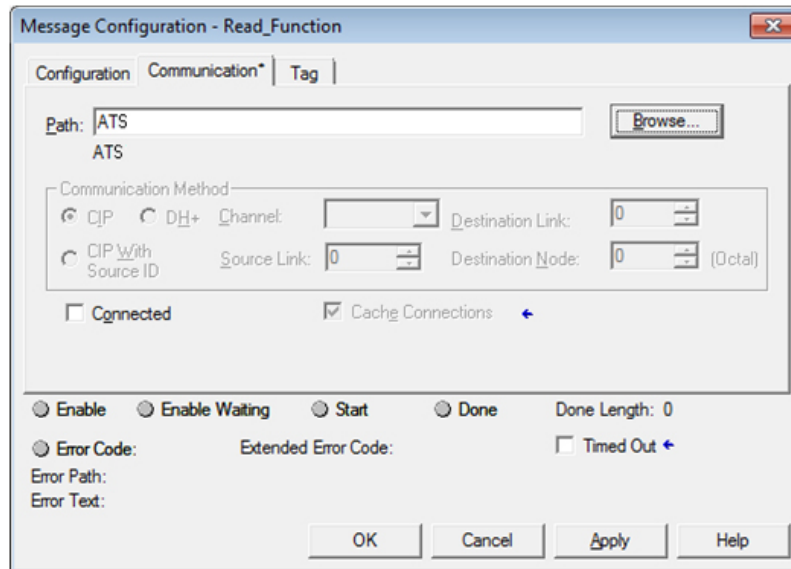

Configuration of Write_Function:

- Click on the "..." button of *Write_Function* block and do the following configuration:
 - On the Configuration tab:
 - Enter the CIP address of **[Acceleration]** ACC parameter: 16#8E/01/3D.
 - Enter the variable where the value to write will be stored (here: *ACC_to_Write*)

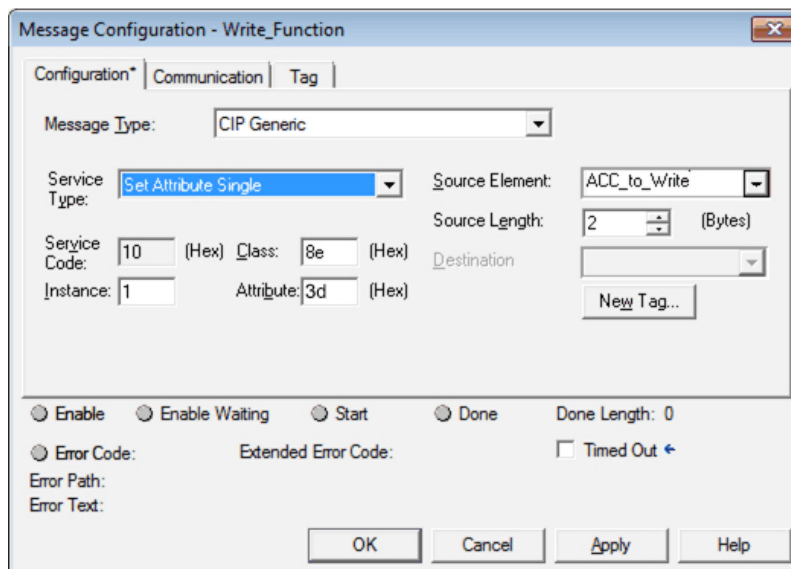

On the Communication tab:

- Configure the Path of the device by clicking on **Browse** button.

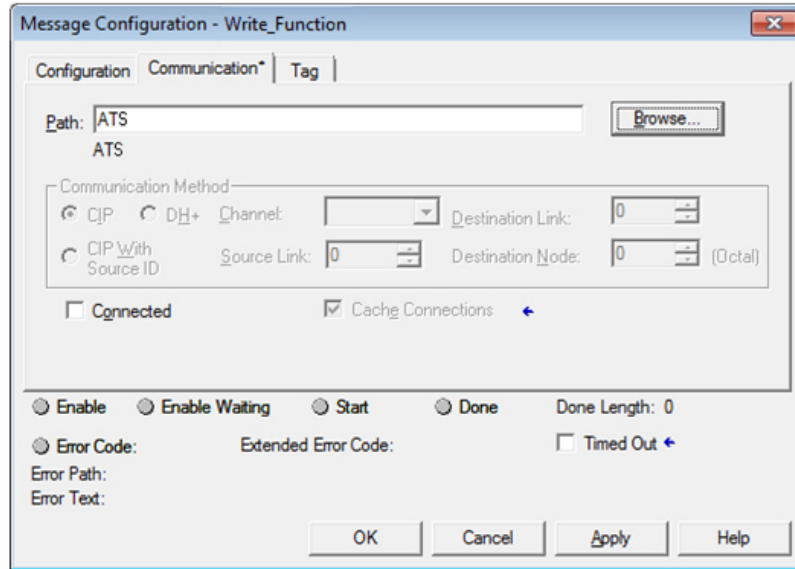

It is possible to read or write the **[Acceleration]** ACC parameter by toggling the *Read* or *Write* bits.

Scope: **ATS_EthernetIP** Shgw... Show All

Name	Value	Style	Data Type	Description
+ ATS:C	{...}	{.}	AB:ETHERNET_MODULE:C:0	
+ ATS:I	{...}	{.}	AB:ETHERNET_MODULE_INT_64Bytes:I:0	
+ ATS:O	{...}	{.}	AB:ETHERNET_MODULE_INT_64Bytes:O:0	
+ Read_ACC	300	Decimal	INT	
+ Read_Function	{...}	{.}	MESSAGE	
+ Write_Function	{...}	{.}	MESSAGE	
+ ACC_to_Write	300	Decimal	INT	
read	0	Decimal	BOOL	
write	0	Decimal	BOOL	

Annex

What's in This Part

Soft Starter State.....	144
How to interpret and react to a NST state	145

Soft Starter State

List of possible soft starter states, visible on the Graphic Display Terminal.

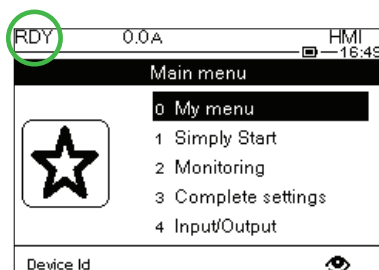

State	Condition
Displayed error label	Detected error. The soft starter is in operating state Fault.
[Ready] RDY	No <i>RUN</i> command and mains supplied.
[No Mains Voltage] NLP	Mains not supplied.
[Control Supply Loss] CLA	The warning [Control Supply Loss] triggers when control supply is lost, the soft starter is not running and [Control Supply Loss] is set to [Warning] .
[Running] RUN	Soft starter in operating state.
[Bypassed] BYP	Bypass active.
[Accelerating] ACC	Soft starter in acceleration phase.
[Decelerating] DEC	Soft starter in deceleration phase.
[Wait for Restart] TBS	Starting time delay not elapsed.
[Freewheel] NST	Soft starter forced to freewheel stop.
[Braking In Progress] BRL	Soft starter in braking phase.
[Current Limitation] CLI	Soft starter in current limitation.
[Motor Preheating] HEA	Motor preheating, correspond to one of the following step of the preheating sequence: <ul style="list-style-type: none"> Preheating order applied but [Time Before Preheat] not elapsed, no preheating current injected yet. Preheating order applied and [Time Before Preheat] elapsed, preheating current is injected.
[Small Motor Test] SST	Small motor test in progress.
[Firmware Update] FWUP	Firmware update in progress.
[Demo Mode] DEMO	Demonstration mode active.
[Simu Mode] SIMU	Simulation mode active.
[JOG mode] JOG	JOG mode active.
[Anti-Jam Mode] AJAM	Anti-Jam mode active.
[STO active] STO	Safe Torque Off active.
[2nd Current Limit] CLI2	2nd current limitation active.

When current limitation is active, the displayed value flashes.

It is still possible to modify the parameters if the soft starter detects an error.

How to interpret and react to a NST state

Root causes of NST state

The following table provides possible root causes of NST status. Several causes can occur at the same time.

NST state	How to move from NST
Command via fieldbus	Check the CMD value. This depends on the control profile used (STD / IO) and the channel used. Refer to the communication manuals for more information.
Run order already present	Check that the digital or virtual inputs are switched back to low level before trying a new command such as forward, reverse, preheating, anti-jam.
3 wire terminal	Check that the DI1 is at high level.
[Device Lock] LES	Check that the digital or virtual input assigned to [Device Lock] is at the right level.
HMI Stop Key	Check the HMI Stop key is not pressed.

NOTE: If a Stop command is applied via a channel different from the active command channel, the NST State is displayed as long as the RUN command from the active command channel is not removed.

Glossary

A

AC:

Alternating Current

Adjustment parameter: A parameter always accessible as **[Access Level]**.

C

Client:

A **client** is a device that is actively polling for data from one or multiple devices.

Configuration Parameter: A parameter affects by the operating states of the machine as **[Motor Nom Current]**.

D

DC:

Direct Current

dec.:

Decimal

DP:

Decentralized Periphery

E

Error :

Discrepancy between a detected (computed, measured, or signaled) value or condition and the specified or theoretically correct value or condition.

F

Factory setting:

Machine status in factory settings when the product was shipped.

Fault Reset:

A function used to restore the soft starter to an operational state after a detected error is cleared by removing the cause of the error so that the error is no longer active.

Fault:

Fault is an operating state. If the monitoring functions detect an error, a transition to this operating state is triggered, depending on the error class. A "Fault reset" is required to exit this operating state after the cause of the detected error has been removed.

H

hex:

Hexadecimal

P

PELV:

Protective Extra Low Voltage, low voltage with isolation. For more information: IEC 60364-4-41.

PLC:

Programmable logic controller.

Power stage:

The power stage controls the motor. The power stage generates current for controlling the motor.

Q

QoS:

Quality of Service

Quick Stop:

The quick Stop function can be used for fast deceleration of a movement as a response to a detected error or via a command.

R

R/WS:

Read and write (write only possible when the soft starter is not in RUN mode). It is not possible to write these parameters in "5-Operation enabled" or "6-Quick stop active" states. If the parameter is written in the "4-Switched on" state, transition to "2-Switch on disabled" is activated.

S

Server:

A **server** is the passive device, waiting for the **client** to poll for data to actually send it.

SNMP:

Simple Network Management Protocol

SNTP:

Simple Network Time Protocol

SYNC:

Synchronization Object

W

Warning:

If the term is used outside the context of safety instructions, a warning alerts to a potential error that was detected by a monitoring function. A warning does not cause a transition of the operating state.

Z

Zone of operation:

This term is used in conjunction with the description of specific hazards, and is defined as it is for a **hazard zone** or **danger zone** in the EC Machinery Directive (2006/42/EC) and in ISO 12100-1.

Schneider Electric
35 rue Joseph Monier
92500 Rueil Malmaison
France

+ 33 (0) 1 41 29 70 00

www.se.com

As standards, specifications, and design change from time to time, please ask for confirmation of the information given in this publication.

© 2024 – Schneider Electric. All rights reserved.

PKR63423.01 – 12/2024