

Altivar Soft Starter ATS490

Soft Starter for Asynchronous Motors

PROFINET Manual - VW3A3647

PKR63424.01

03/2025



Legal Information

The information provided in this document contains general descriptions, technical characteristics and/or recommendations related to products/solutions.

This document is not intended as a substitute for a detailed study or operational and site-specific development or schematic plan. It is not to be used for determining suitability or reliability of the products/solutions for specific user applications. It is the duty of any such user to perform or have any professional expert of its choice (integrator, specifier or the like) perform the appropriate and comprehensive risk analysis, evaluation and testing of the products/solutions with respect to the relevant specific application or use thereof.

The Schneider Electric brand and any trademarks of Schneider Electric SE and its subsidiaries referred to in this document are the property of Schneider Electric SE or its subsidiaries. All other brands may be trademarks of their respective owner.

This document and its content are protected under applicable copyright laws and provided for informative use only. No part of this document may be reproduced or transmitted in any form or by any means (electronic, mechanical, photocopying, recording, or otherwise), for any purpose, without the prior written permission of Schneider Electric.

Schneider Electric does not grant any right or license for commercial use of the document or its content, except for a non-exclusive and personal license to consult it on an "as is" basis.

Schneider Electric reserves the right to make changes or updates with respect to or in the content of this document or the format thereof, at any time without notice.

To the extent permitted by applicable law, no responsibility or liability is assumed by Schneider Electric and its subsidiaries for any errors or omissions in the informational content of this document, as well as any non-intended use or misuse of the content thereof.

Table of Contents

About the document	5
Validity note	6
Document Scope.....	7
Safety Information	8
Qualification of Personnel.....	9
Intended Use.....	9
Product related information.....	9
Related Documents	14
Electronic product data sheet	16
Terminology	17
Structure of the Parameter Table	18
Contact us	19
Hardware Setup	20
Hardware Presentation	21
Installation of the fieldbus module	22
Electrical Installation	24
Cable Routing Practices.....	25
Automation Commissioning Only	28
Cybersecurity Generalities	29
PROFINET Basics.....	33
Software Setup.....	35
Software Overview	36
PROFINET module Basic Settings.....	37
Profinet module commissioning	40
S2 Redundancy.....	42
Most Common parameters	43
Operation	47
Profile.....	48
Functional Profiles Supported by the Altivar Soft Starter	49
Command Channel.....	50
Command Register and Status — [Standard Profile]	52
I/O Profile.....	59
Extended Control Word and Internal State register in [Standard Profile] & [I/O Profile].....	63
Extended Control Word	64
Internal State register	65
Starting Sequence	66
Sequence for a Soft starter	67
Sequence for a Soft starter with Mains Contactor Control.....	70
Description Telegram 100, 101, 102, 106, 107	72
Configuring the soft starter with TIA Portal	76
Configuration of a soft starter with the Telegram 100	77
Configuring a soft starter with the Telegram 101, 102, 106, or 107	78
Parameters Management with the Telegram 100, 101, 102, 106, 107	79
Identification and Maintenance Data	80
Soft Starter Parameters Access Channel.....	81
Acyclic soft starter parameters access.....	82

Device profile request structure	83
Soft Starter Parameters Access	84
Monitoring of Communication Channel	86
Diagnostics and Troubleshooting	87
Fieldbus Status LEDs	88
Connection problem with the fieldbus module	91
Configuring Communication Error Response	92
Communication troubleshooting	93
Fieldbus Response Test	94
Control-Signal Diagnostics	96
Communication error codes.....	97
Glossary	102

About the document

What's in This Part

Validity note	6
Document Scope	7
Safety Information	8
Related Documents	14
Electronic product data sheet	16
Terminology	17
Structure of the Parameter Table	18
Contact us	19

Validity note

Original instructions and information given in the present document have been written in English (before optional translation).

NOTE: The products listed in the document are not all available at the time of publication of this document online. The data, illustrations and product specifications listed in the guide will be completed and updated as the product availabilities evolve. Updates to the guide will be available for download once products are released onto the market.

This documentation is valid only for ATS490.

The characteristics that are presented in this manual should be the same as those characteristics that appear online. In line with our policy of constant improvement, we may revise content over time to improve clarity and accuracy. If you see a difference between the manual and online information, use the online information as your reference.

The technical characteristics of the devices described in the present document also appear online. To access the information online:

Step	Action
1	Go to the Schneider Electric home page www.se.com .
2	In the Search box type the reference of the product or the name of a product range. <ul style="list-style-type: none"> • Do not include blank spaces in the reference or product range. • To get information on grouping similar modules, use asterisks (*).
3	If you entered a reference, go to the Product Datasheets search results and click on the reference that interests you. If you entered the name of a product range, go to the Product Ranges search results and click on the product range that interests you.
4	If more than one reference appears in the Products search results, click on the reference that interests you.
5	Depending on the size of your screen, you may need to scroll down to see the data sheet.
6	To save or print a data sheet as a .pdf file, click Download XXX product datasheet .

Document Scope

The purpose of this document is to:

- Show you how to install the PROFINET fieldbus on your soft starter.
- Show you how to configure the soft starter to use PROFINET fieldbus.

NOTE: Read and understand this document and all related documents (see below) before installing, operating, or maintaining your soft starter.

Safety Information

What's in This Chapter

Qualification of Personnel9
 Intended Use9
 Product related information9

Important Information

Read these instructions carefully, and look at the equipment to become familiar with the device before trying to install, operate, service, or maintain it. The following special messages may appear throughout this documentation or on the equipment to warn of potential hazards or to call attention to information that clarifies or simplifies a procedure.



The addition of this symbol to a “Danger” or “Warning” safety label indicates that an electrical hazard exists which will result in personal injury if the instructions are not followed.



This is the safety alert symbol. It is used to alert you to potential personal injury hazards. Obey all safety messages that follow this symbol to avoid possible injury or death.

⚠ DANGER
DANGER indicates a hazardous situation which, if not avoided, will result in death or serious injury.

⚠ WARNING
WARNING indicates a hazardous situation which, if not avoided, could result in death or serious injury.

⚠ CAUTION
CAUTION indicates a hazardous situation which, if not avoided, could result in minor or moderate injury.

NOTICE
NOTICE is used to address practices not related to physical injury.

Please Note

Electrical equipment should be installed, operated, serviced, and maintained only by qualified personnel. No responsibility is assumed by Schneider Electric for any consequences arising out of the use of this material.

A qualified person is one who has skills and knowledge related to the construction and operation of electrical equipment and its installation, and has received safety training to recognize and avoid the hazards involved.

Qualification of Personnel

Only appropriately trained persons who are familiar with and understand the contents of this manual and all other pertinent product documentation are authorized to work on and with this product. In addition, these persons must have received safety training to recognize and avoid hazards involved. These persons must have sufficient technical training, knowledge and experience and be able to foresee and detect potential hazards that may be caused by using the product, by changing the settings and by the mechanical, electrical and electronic equipment of the entire system in which the product is used. All persons working on and with the product must be fully familiar with all applicable standards, directives, and accident prevention regulations when performing such work.

Intended Use

This product is intended for industrial use according to this manual.

The product may only be used in compliance with all applicable safety standard and local regulations and directives, the specified requirements and the technical data. The product must be installed outside the hazardous ATEX zone. Prior to using the product, you must perform a risk assessment in view of the planned application. Based on the results, the appropriate safety measures must be implemented. Since the product is used as a component in an entire system, you must ensure the safety of persons by means of the design of this entire system (for example, machine design). Any use other than the use explicitly permitted is prohibited and can result in hazards.

Product related information

Read and understand these instructions before performing any procedure with this soft starter.

DANGER

HAZARD OF ELECTRIC SHOCK, EXPLOSION, OR ARC FLASH

- Only appropriately trained persons who are familiar with and fully understand the contents of the present manual and all other pertinent product documentation and who have received all necessary training to recognize and avoid hazards involved are authorized to work on and with this equipment.
- Installation, adjustment, repair and maintenance must be performed by qualified personnel.
- Verify compliance with all local and national electrical code requirements as well as all other applicable regulations with respect to grounding of all equipment.
- Only use properly rated, electrically insulated tools and measuring equipment.
- Do not touch unshielded components or terminals with voltage present.
- Prior to performing any type of work on the equipment, block the motor shaft to prevent rotation.
- Insulate both ends of unused conductors of the motor cable.

Failure to follow these instructions will result in death or serious injury.

⚡⚠ DANGER**HAZARD OF ELECTRIC SHOCK, EXPLOSION, OR ARC FLASH**

Before performing work on the equipment:

- Use all required personal protective equipment (PPE).
- Disconnect all power, including external control power that may be present. Take into account that the circuit breaker or main switch does not de-energize all circuits.
- Place a "Do Not Turn On" label on all power switches related to the equipment.
- Lock all power switches in the open position.
- Verify the absence of voltage using a properly rated voltage sensing device.

Before applying voltage to the equipment:

- Verify that the work has been completed and that the entire installation cannot cause hazards.
- If the mains input terminals and the motor output terminals have been grounded and short-circuited, remove the ground and the short circuits on the mains input terminals and the motor output terminals.
- Verify proper grounding of all equipment.
- Verify that all protective equipment such as covers, doors, grids is installed and/or closed.

Failure to follow these instructions will result in death or serious injury.

⚡⚠ DANGER**HAZARD OF ELECTRIC SHOCK, EXPLOSION, OR ARC FLASH**

- Never operate energized switch with door open.
- Turn off switch before removing or installing fuses or making load side connections.
- Do not use renewable link fuses in fused switches.

Failure to follow these instructions will result in death or serious injury.

Damaged products or accessories may cause electric shock or unanticipated equipment operation.

⚡⚠ DANGER**ELECTRIC SHOCK OR UNANTICIPATED EQUIPMENT OPERATION**

Do not use damaged products or accessories.

Failure to follow these instructions will result in death or serious injury.

Contact your local Schneider Electric sales office if you detect any damage whatsoever.

This equipment has been designed to operate outside of any hazardous location. Only install this equipment in zones known to be free of a hazardous atmosphere.

⚠ DANGER**POTENTIAL FOR EXPLOSION**

Install and use this equipment in non-hazardous locations only.

Failure to follow these instructions will result in death or serious injury.

Your application consists of a whole range of different interrelated mechanical, electrical, and electronic components, the device being just one part of the application. The device by itself is neither intended to nor capable of providing the entire functionality to meet all safety-related requirements that apply to your application. Depending on the application and the corresponding risk assessment to be conducted by you, a whole variety of additional equipment is required such as, but not limited to, external monitoring devices, guards, etc.

As a designer/manufacturer of machines, you must be familiar with and observe all standards that apply to your machine. You must conduct a risk assessment and determine the appropriate Performance Level (PL) and/or Safety Integrity Level (SIL) and design and build your machine in compliance with all applicable standards. In doing so, you must consider the interrelation of all components of the machine. In addition, you must provide instructions for use that enable the user of your machine to perform any type of work on and with the machine such as operation and maintenance in a safe manner.

The present document assumes that you are fully aware of all normative standards and requirements that apply to your application. Since the device cannot provide all safety-related functionality for your entire application, you must ensure that the required Performance Level and/or Safety Integrity Level is reached by installing all necessary additional equipment.

▲ WARNING
<p>INSUFFICIENT PERFORMANCE LEVEL/SAFETY INTEGRITY LEVEL AND/OR UNINTENDED EQUIPMENT OPERATION</p> <ul style="list-style-type: none"> • Conduct a risk assessment according to EN ISO 12100 and all other standards that apply to your application. • Use redundant components and/or control paths for all critical control functions identified in your risk assessment. • Verify that the service life of all individual components used in your application is sufficient for the intended service life of your overall application. • Perform extensive commissioning tests for all potential error situations to verify the effectiveness of the safety-related functions and monitoring functions implemented, for example, but not limited to, speed monitoring by means of encoders, short circuit monitoring for all connected equipment, correct operation of brakes and guards. • Perform extensive commissioning tests for all potential error situations to verify that the load can be brought to a safe stop under all conditions. <p>Failure to follow these instructions can result in death, serious injury, or equipment damage.</p>

Product may perform unexpected movements because of incorrect wiring, incorrect settings, incorrect data or other errors.

▲ WARNING
<p>UNANTICIPATED EQUIPMENT OPERATION</p> <ul style="list-style-type: none"> • Carefully install the wiring in accordance with the EMC requirements. • Do not operate the product with unknown or unsuitable settings or data. • Perform a comprehensive commissioning test. <p>Failure to follow these instructions can result in death, serious injury, or equipment damage.</p>

▲ WARNING**LOSS OF CONTROL**

- The designer of any control scheme must consider the potential failure modes of control paths and, for critical control functions, provide a means to achieve a safe state during and after a path failure. Examples of critical control functions are emergency stop, overtravel stop, power outage and restart.
- Separate or redundant control paths must be provided for critical control functions.
- System control paths may include communication links. Consideration must be given to the implications of unanticipated transmission delays or failures of the link.
- Observe all accident prevention regulations and local safety guidelines (1).
- Each implementation of the product must be individually and thoroughly tested for proper operation before being placed into service.

Failure to follow these instructions can result in death, serious injury, or equipment damage.

(1) For USA: Additional information, refer to NEMA ICS 1.1 (latest edition), Safety Guidelines for the Application, Installation and Maintenance of Solid State Control.

Machines, controllers, and related equipment are usually integrated into networks. Unauthorized persons and malware may gain access to the machine as well as to other devices on the network/fieldbus of the machine and connected networks via insufficiently secure access to software and networks.

▲ WARNING**UNAUTHORIZED ACCESS TO THE MACHINE VIA SOFTWARE AND NETWORKS**

- In your hazard and risk analysis, consider all hazards that result from access to and operation on the network/fieldbus and develop an appropriate cyber security concept.
- Verify that the hardware infrastructure and the software infrastructure into which the machine is integrated as well as all organizational measures and rules covering access to this infrastructure consider the results of the hazard and risk analysis and are implemented according to best practices and standards covering IT security and cyber security (such as: ISO/IEC 27000 series, Common Criteria for Information Technology Security Evaluation, ISO/IEC 15408, IEC 62351, ISA/IEC 62443, NIST Cybersecurity Framework, Information Security Forum - Standard of Good Practice for Information Security, SE recommended Cybersecurity Best Practices*).
- Verify the effectiveness of your IT security and cyber security systems using appropriate, proven methods.

Failure to follow these instructions can result in death, serious injury, or equipment damage.

(*) : SE Recommended Cybersecurity Best Practices can be downloaded on SE.com.

▲ WARNING**LOSS OF CONTROL**

Perform a comprehensive commissioning test to verify that communication monitoring properly detects communication interruptions.

Failure to follow these instructions can result in death, serious injury, or equipment damage.

This product meets the EMC requirements according to the standard IEC 60947-4-2. This device has been designed for environment A. Use of this product in a domestic environment (B environment) may cause unwanted radio interference.

▲ WARNING

RADIO INTERFERENCE

In a domestic environment (B environment), this product may cause radio interference in which case supplementary mitigation measures may be required.

Failure to follow these instructions can result in death, serious injury, or equipment damage.

NOTICE

DESTRUCTION DUE TO INCORRECT MAINS VOLTAGE

Before switching on and configuring the product, verify that it is approved for the mains voltage.

Failure to follow these instructions can result in equipment damage.

Related Documents

Use your tablet or your PC to quickly access detailed and comprehensive information on all our products on www.se.com The Internet site provides the information you need for products and solutions:

- The whole catalog for detailed characteristics and selection guides
- The CAD files to help design your installation, available in over 20 different file formats
- All software and firmware to maintain your installation up to date
- A large quantity of White Papers, Environment documents, Application solutions, Specifications... to gain a better understanding of our electrical systems and equipment or automation
- And finally all the User Guides related to your soft starter, listed below:

Catalog

Title of documentation	Reference number
Catalog: Altivar Soft Starter ATS490	DIA2ED2240603EN (English) DIA2ED2240603FR (French)

Documentations

Title of documentation	Reference number
ATS490 Getting Started	PKR63410 (English), PKR63411 (French) PKR63412 (Spanish), PKR63413 (Italian) PKR63414 (German), PKR63415 (Chinese) PKR63416 (Portuguese), PKR63417 (Turkish)
ATS490 Getting Started Manual Annex for UL	PKR63418 (English)
ATS490 User Manual	PKR52680 (English), PKR52681 (French) PKR52682 (Spanish), PKR52683 (Italian) PKR52684 (German), PKR52685 (Chinese) PKR52686 (Portuguese), PKR52687 (Turkish)
ATS490 Embedded Safety Function Manual	PKR63419 (English)
ATS490 ATEX Manual	BQT74920 (English)
ATS490 Embedded Modbus RTU Manual	PKR63421 (English)
ATS490 EtherNet Manual	PKR63423 (English)
ATS490 PROFIBUS DP Manual (VW3A3607)	PKR63425 (English)
ATS490 CANopen Manual (VW3A3608, VW3A3618, VW3A3628)	PKR63426 (English)
ATS490 PROFINET Manual (VW3A3647)	PKR63424 (English)
ATS490 Communication Parameter Addresses	PKR63420 (English)
Recommended Cybersecurity Best Practices	CS-Best-Practices-2019-340 (English)

You can download there technical publications and other technical information from our website at www.se.com/en/download.

Videos

Title of documentation	Reference number
Video: Getting Started with ATS490	FAQ000263202 (English)

Software

Title of documentation	Reference number
SoMove: FDT	SoMove FDT (English, French, German, Spanish, Italian, Chinese)
ATS490: DTM	ATS490 DTM Library EN (English – to be installed first) ATS490 DTM Lang FR (French) ATS490 DTM Lang SP (Spanish) ATS490 DTM Lang IT (Italian) ATS490 DTM Lang DE (German) ATS490 DTM Lang CN (Chinese)

Electronic product data sheet

Scan the QR code in front of the soft starter to get the product data sheet.

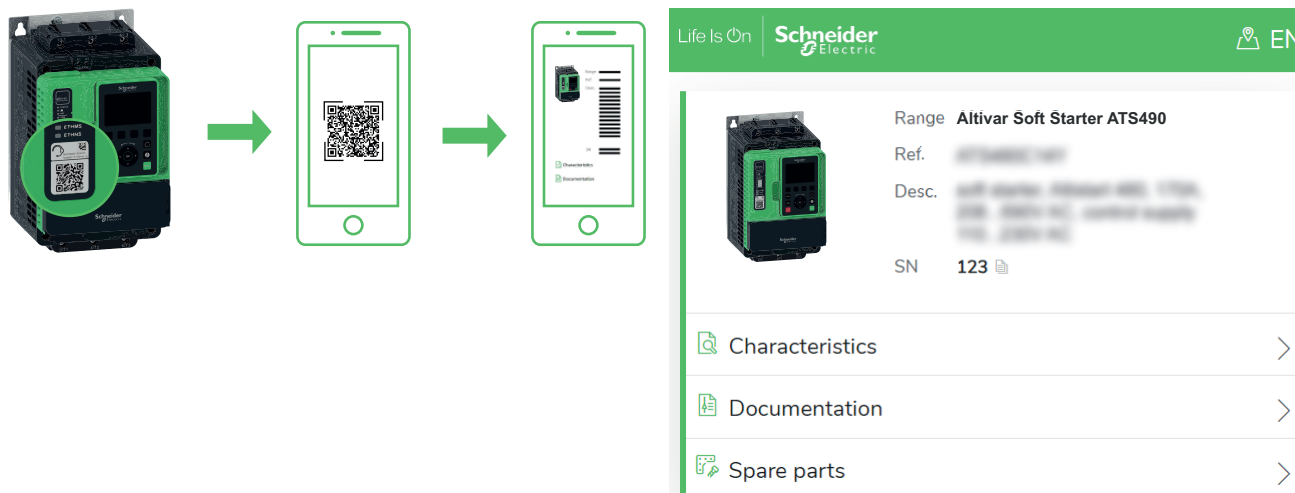

The diagram illustrates the process of accessing the product data sheet for a soft starter. It starts with a physical soft starter unit (ATS490) which has a QR code on its front panel. An arrow points to a smartphone scanning this QR code. A second arrow points to a smartphone displaying the product data sheet. The screenshot shows the Schneider Electric mobile application interface with the following details:

- Range: **Altivar Soft Starter ATS490**
- Ref. [blurred]
- Desc. [blurred]
- SN: **123**
- Characteristics
- Documentation
- Spare parts

Scanning the QR Code gives you access to :

- Product ID Card : Product range, Reference, short description and a Serial Number (Use the serial number to retrieve the product's manufacturing date).
- The product characteristics : Main characteristics, environment, packing units, sustainability...
- Documentation : Technical Guidance at Glance (Presentation, Dimensions, Mounting, Wiring, Commissioning...) and Product Documentation (User guide, Instructions sheets, Certificates, How To videos...)
- Spare parts for your product

Terminology

The technical terms, terminology, and the corresponding descriptions in this manual normally use the terms or definitions in the relevant standards.

In the area of soft starters this includes, but is not limited to, terms such as **error**, **error message**, **failure**, **fault**, **fault reset**, **protection**, **safe state**, **safety function**, **warning**, **warning message**, and so on.

Among others, these standards include:



- ISO 13849-1 & 2 Safety of machinery - safety related parts of control systems
- IEC 61158 series: Industrial communication networks - Fieldbus specifications
- IEC 61784 series: Industrial communication networks - Profiles
- IEC 60204-1: Safety of machinery - Electrical equipment of machines – Part 1: General requirements
- IEC 60947–1 Low–Voltage Switchgear and Control Gear – General rules
- IEC 60947–4-2 Semiconductor Motor controllers, Starters and Soft Starters
- IEC 62443: Security for industrial automation and control systems

In addition, the term **zone of operation** is used in conjunction with the description of specific hazards, and is defined as it is for a **hazard zone** or **danger zone** in the EC Machinery Directive (2006/42/EC) and in ISO 12100.

Also see the glossary at the end of this manual.

Structure of the Parameter Table

General Legend

Pictogram	Description
	Power cycle must be performed after setting this parameter.
	Read only parameter, mainly used for monitoring.
	Expert mode required to access this parameter.

Contact us

Select your country on www.se.com/contact.

Schneider Electric Industries SAS

Head Office

35, rue Joseph Monier

92500 Rueil-Malmaison

France

Hardware Setup

What's in This Part

Hardware Presentation	21
Installation of the fieldbus module	22
Electrical Installation.....	24
Cable Routing Practices	25
Automation Commissioning Only	28

Hardware Presentation

PROFINET Fieldbus Module

The figure shows a PROFINET fieldbus module with 2 RJ45 connectors:



Firmware version compatibility

The VW3A3647 option module version V3.2.12 and higher is compliant with ATS490 product range with firmware V1.2 or higher. When the device has a firmware version that does not support VW3A3647 option module, a **[Internal Error 6]** INF6 error (see [Internal Error 6] InF6 Error, page 100) is triggered and a firmware update of the device is required via SoMove.

NOTE: It is recommended to update device firmware without the option module plugged in, otherwise a **[Incorrect Config]** CFF would be triggered after the update.

The associated GSDML is named as the following example:

GSDML-V2.44-Schneider-ATS4X0-YYYYMMDD.xml

The files are available on www.se.com.

Installation of the fieldbus module

Before starting

Verify that the catalog number printed on the label corresponds to the purchase order.

Remove the fieldbus module from its packaging and check that it has not been damaged in transit.

Damaged products or accessories may cause electric shock or unanticipated equipment operation.

DANGER

ELECTRIC SHOCK OR UNANTICIPATED EQUIPMENT OPERATION

Do not use damaged products or accessories.

Failure to follow these instructions will result in death or serious injury.

Contact your local Schneider Electric sales office if you detect any damage whatsoever.

Inserting the fieldbus module

The table provides the procedure for insertion of the fieldbus module in the soft starter:

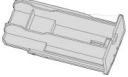
Step	Action
1	Ensure that the power is off.
2	Locate the fieldbus module slot on the bottom of the control part.
3	Remove the plastic cover module with the help of a screwdriver. 
4	Insert the module.
5	Check that the module is correctly inserted and locked mechanically in the soft starter.
6	Wire the fieldbus module to the automate.
7	Add the corresponding sticker on the LED front panel of the soft starter.

1 Fieldbus Module Slot

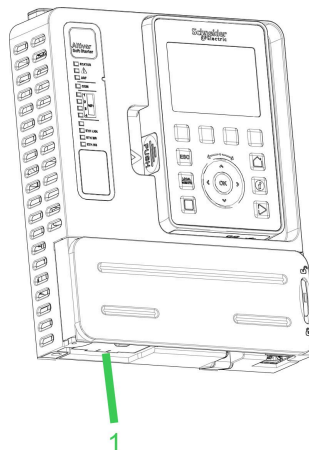

Removing the fieldbus module

The table provides the procedure for removal of the fieldbus module from the soft starter:

Step	Action
1	Ensure that the power is off.
2	Remove the connection cables.
3	Press the strip. 
4	Remove the module while maintaining the strip pressed.

NOTE: When removing or inserting the module at next power on, an error can be triggered if the device topology has changed.

NOTE: If the message is validated, a reset of the error is performed due to a factory setting of the device.

NOTE: In case of incompatible module, the error **[Internal Error 6]** INF6, page 100 is triggered.

Electrical Installation

Pin Layout

The VW3A3647 option module is equipped with 2 RJ45 female sockets for the PROFINET connection.

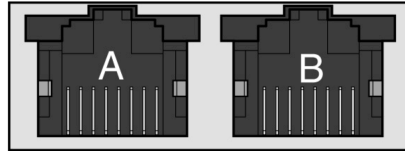

8 7 6 5 4 3 2 1 8 7 6 5 4 3 2 1

The table provides the pin out details of each RJ45 connector:

Pin	Signal	Meaning
1	Tx+	Ethernet transmit line +
2	Tx-	Ethernet transmit line –
3	Rx+	Ethernet receive line +
4	–	–
5	–	–
6	Rx-	Ethernet receive line –
7	–	–
8	–	–

Cable Specification

Cable specifications are as follows:

- Ethernet cable must be AWG24 & SF/FTP
- Minimum Cat 5e,
- Use equipotential bonding conductors (100 BASE-TX, category 5e or industrial Ethernet fast connect)
- Connector RJ45, no crossover cable
- Shield: both ends grounded
- Twisted-pair cable
- Verify that wiring, cables, and connected interfaces meet the PELV requirements.
- Maximum cable length per segment = 100 m (328 ft)

Cable Routing Practices

Installation Topology

The VW3A3647 option module, with its 2 RJ45 connector, enables several architecture solutions:

- **Daisy chain topology**
- **Star topology**
- **Ring topology**

Daisy chain Topology

- **Physical architecture:**



- **Daisy chain topology on TIA Portal:**

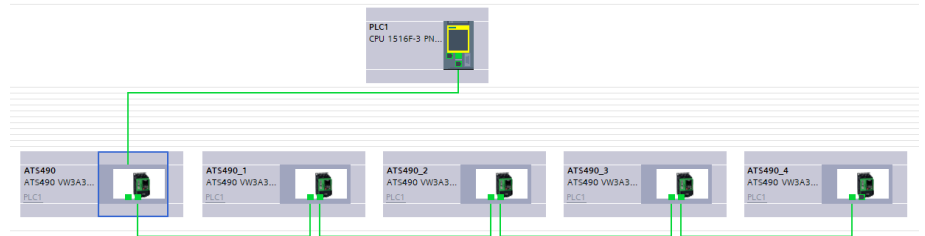

Star Topology

- **Physical architecture:**



- **Star topology on TIA Portal:**

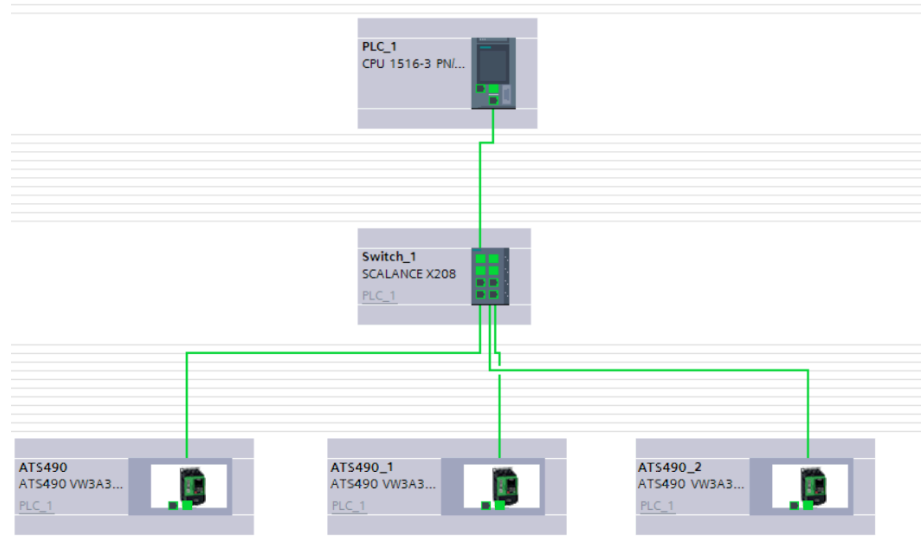

Ring Topology

- **Physical architecture:**



- **Topology on TIA Portal:**

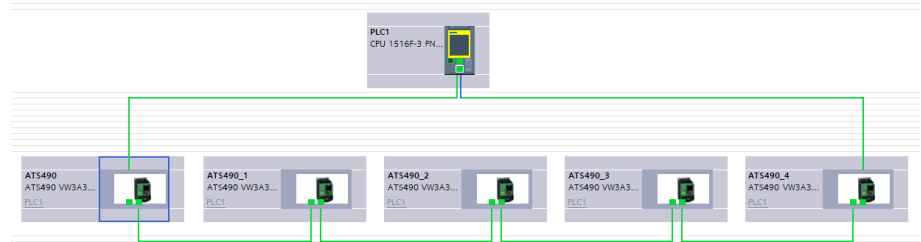

The ring topology can only be used with a media redundancy protocol (MRP) capable managed device.

Watchdog configuration

In order to avoid triggering untimely **[Fieldbus Com Interrupt] CNE**, the bus watchdog shall be configured by increasing manually the "Update Time" or the "IO data" on TIA Portal.

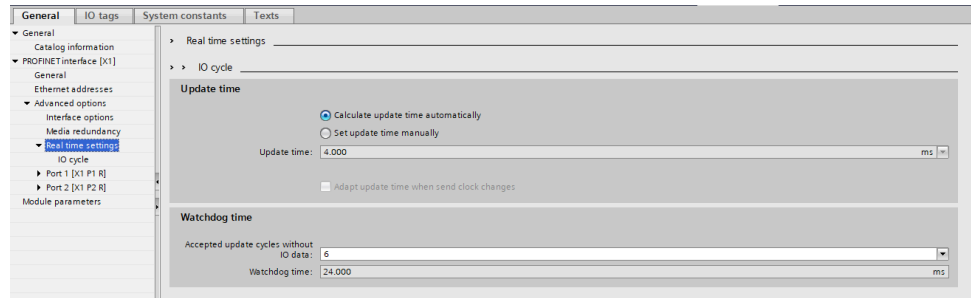

Automation Commissioning Only

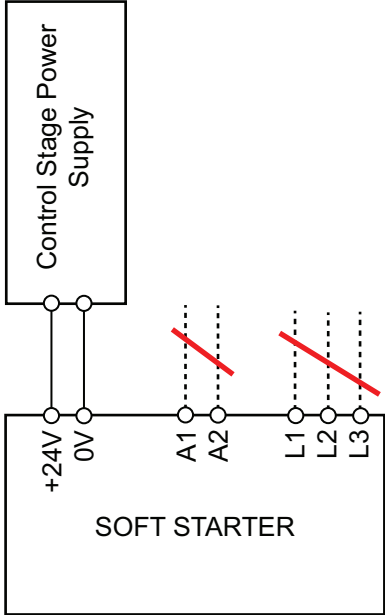
Control stage supplied via +24 V of the control board	Use case
 <p>The diagram shows a 'Control Stage Power Supply' box connected to the '+24V' and '0V' terminals of the 'SOFT STARTER'. The motor power terminals 'A1', 'A2', 'L1', 'L2', and 'L3' are shown with red diagonal lines through them, indicating they are not connected in this configuration.</p>	<p>By supplying the product only with +24V, only programming is possible. No motor power supply is possible.</p>

Cybersecurity Generalities

Title of documentation	Catalog number
Recommended Cybersecurity Best Practices	7EN52-0390 (English)

Overview

The objective of Cybersecurity is to help provide increased levels of protection for information and physical assets from theft, corruption, misuse, or accidents while maintaining access for their intended users.

No single Cybersecurity approach is adequate. Schneider Electric recommends a defense-in-depth approach. Conceived by the National Security Agency (NSA), this approach layers the network with security features, appliances, and processes.

The basic components of this approach are:

- Risk assessment
- A security plan built on the results of the risk assessment
- A multi-phase training campaign
- Physical separation of the industrial networks from enterprise networks using a demilitarized zone (DMZ) and the use of firewalls and routing to establish other security zones
- System access control
- Device hardening
- Network monitoring and maintenance

This chapter defines the elements that help you configure a system that is less susceptible to cyber-attacks.

Network administrators, system integrators and personnel that commission, maintain or dispose of a device should:

- Apply and maintain the device's security capabilities. See for details
- Review assumptions about protected environments. See sub-chapter for details
- Address potential risks and mitigation strategies. See for details
- Follow recommendations to optimize cybersecurity

For detailed information on the system defense-in-depth approach, refer to the TVDA: How Can I Reduce Vulnerability to Cyber Attacks (STN V3.0) on se.com.

To submit a Cybersecurity question, report security issues, or get the latest news from Schneider Electric, visit the Schneider Electric website.

▲ WARNING

POTENTIAL COMPROMISE OF SYSTEM AVAILABILITY, INTEGRITY, AND CONFIDENTIALITY

- Place networked devices behind multiple layers of cyber defenses (such as firewalls, network segmentation, and network intrusion detection and protection).
- Use cybersecurity best practices (for example: least rights, separation of duties) to help prevent unauthorized exposure, loss or modification of data and logs, interruption of services, or unintended operation.

Failure to follow these instructions can result in death, serious injury, or equipment damage.

Protected Environment Assumptions

Machines, controllers, and related equipment are usually integrated into networks. Unauthorized persons and malware may gain access to the machine as well as to other devices on the network/fieldbus of the machine and connected networks via insufficiently secure access to software and networks.

⚠ WARNING
UNAUTHORIZED ACCESS TO THE MACHINE VIA SOFTWARE AND NETWORKS
<ul style="list-style-type: none">• In your hazard and risk analysis, consider all hazards that result from access to and operation on the network/fieldbus and develop an appropriate cyber security concept.• Verify that the hardware infrastructure and the software infrastructure into which the machine is integrated as well as all organizational measures and rules covering access to this infrastructure consider the results of the hazard and risk analysis and are implemented according to best practices and standards covering IT security and cyber security (such as: ISO/IEC 27000 series, Common Criteria for Information Technology Security Evaluation, ISO/ IEC 15408, IEC 62351, ISA/IEC 62443, NIST Cybersecurity Framework, Information Security Forum - Standard of Good Practice for Information Security, SE recommended Cybersecurity Best Practices*).• Verify the effectiveness of your IT security and cyber security systems using appropriate, proven methods.
Failure to follow these instructions can result in death, serious injury, or equipment damage.

(*) : SE Recommended Cybersecurity Best Practices can be downloaded on SE.com.

Additionally, use a layered network approach with multiple security and defense controls in your IT and control system to minimize data protection gaps, reduce single-points of failure and create a strong cybersecurity posture. The more layers of security in your network, the harder it is to breach defenses, take digital assets or cause disruption.

Control System - Cybersecurity policy

- Cybersecurity governance – available and up-to-date guidance on governing the use of information and technology assets in your company that is matching with a dedicated risk analysis about the control system
- The access control policy defined in the cybersecurity governance is strictly applied. In particular, it guarantees the authenticity of privileged operations. For example operations that can alter the critical assets.
- The instructions and procedures should structure the roles and responsibilities in terms of security within the organization; in other words, who is authorized to perform what and when. These should be known by the users.
- Define information security continuous monitoring (ISCM) to maintain the awareness of information security, vulnerabilities and threats to your organization.
- Perform patch management by applying security patches from vendor to ensure stability and completeness.

Physical perimeter security

- Set up the devices in an enclosed area with physical access control to prevent authorized access to the device, with dedicated monitoring

Physical network segmentation

Independence from non-control system networks – the control system provides network services to control system networks, critical or non-critical, without a connection to non-control system networks

- Physically segment control system networks from non-control system network
- Physically segment critical control system networks from non-critical control system networks

Logical isolation of critical networks

The control system provides the capability to logically and physically isolate critical control system networks from non-critical control system networks. For example, using VLANs.

Zone boundary protection – the control system provides the capability to:

- Manage connections through managed interfaces consisting of appropriate boundary protection devices, such as: proxies, gateways, routers, firewalls, and encrypted tunnels
- Use an effective architecture, for example, firewalls protecting application gateways residing in a DMZ
- Control system boundary protections at any designated alternate processing sites should provide the same levels of protection as that of the primary site, for example, data centers

No public internet connectivity – access from the control system to the internet is not recommended

Information disclosure prevention

- Encrypt protocol transmissions over all external connections using an encrypted tunnel, TLS wrapper or a similar solution
- Reduce access to control system information by distributing permissions according to predefined access control with least privilege practices

Control against malware

- Detection, prevention, and recovery controls to help protect against malware are implemented and combined with appropriate user awareness
- Any computer in use on the control system either on premise or temporarily connected, should have an updated anti-virus, anti-malware, anti-ransomware application activated during the use

Resource & control system availability

- Ensure continuity of service – ability to break the connections between different network segments or use duplicate devices in response to an incident. S2 redundancy of controllers or network device like switches or similar solution.
- Manage communication loads – the control system provides the capability to manage communication loads to mitigate the effects of information flooding types of DoS (Denial of Service) events

Potential Risks and Compensating Controls

Address potential risks using these compensating controls:

Area	Issue	Risk	Compensating controls
Secure protocols.	The device does not have the capability to transmit data encrypted using these protocols: <ul style="list-style-type: none"> • PROFINET • SNMP 	If a malicious user gained access to your network, they could intercept communication.	For transmitting data over internal network, physically or logically segment your network. For transmitting data over external network, encrypt protocol transmissions over all external connections using an encrypted tunnel, TLS wrapper or a similar solution. See Protected Environment Assumptions .
Security banners	The local graphic display terminal cannot display the security banner.	The users connecting to the soft starter will not be able to be warned about potential security notifications.	If such security notification shall be shared with users, then a local message shall be added close to the soft starter. Example : A sticker on the electrical cabinet or the electrical room can inform user about specific security considerations

Data Flow Restriction

A firewall device is required to secure the access to the device and limit the data flow.

For detailed information, refer to the TVDA: How Can I Reduce Vulnerability to Cyber Attacks (STN V3.0).

Device Recovery and Reconstitution

Control system backup – available and up-to-date backups for recovery from a control system failure.

Available and up-to-date firmware package for recovery from a system disaster. The customer stores the current used firmware version package or the latest up-to-date firmware package available on **se.com**.

Both Control System backup and firmware package, shall be considered as assets with dedicated risk analysis according to your local Cybersecurity policy.

Make sure the access and use of these files are protected by appropriate security controls to ensure the trust, availability and effectiveness of the device’s disaster recovery plan.

NOTE:

- Complete device recovery can be performed by applying the firmware update package and the device backup image previously stored by the customer.
- In case of a firmware recovery on the product is not possible, please contact your local Schneider Electric representative.

PROFINET Basics

Introduction

- PROFINET RT extends Ethernet by an advanced industrial protocol management as an application layer for automation applications. In this way, Ethernet protocol is suited for industrial control.
- Products from different manufacturers can be networked by using a PROFINET-compliant switch.

PROFINET and Ethernet Features

The product supports the following functions:

- Support of MRP (Media Redundancy Protocol)
- S2 redundancy
- Firmware update of the module (not available from the PROFINET option module).
- I&M0, I&M1, I&M2, I&M3 and I&M5

Identification and Maintenance Data

Identification & maintenance (I&M) is established through PNO.

Supports the user during various scenarios of the device life cycle, such as:

- Configuration
- Commissioning
- Repair and update
- Operation and visualization

The access to the identification & maintenance data can be achieved using the PROFINET mechanisms (IEC 61158-6).

I&M Record

Champ	Number of Bytes	Value	Description
I&M (index AFF0)			
<i>HEADER_MANUF_SPEC</i>	6 bytes	String	Manufacturer-specific field
<i>MANUFACTURER_ID</i>	2 bytes	01 hex, 29 hex	129 hex: Schneider Electric
<i>ORDER_ID</i>	20 bytes	Identification object ID 1	Commercial name of the soft starter
<i>SERIAL_NUMBER</i>	16 bytes	Serial number	C1P1 to C1P8 Note: the full serial number can be viewed in the [Identification] IOD menu
<i>HARDWARE_REVISION</i>	2 bytes	–	–
<i>SOFTWARE_REVISION</i>	4 bytes	'V', A, B, C	C1SV
<i>REVISION_COUNTER</i>	2 bytes	xx hex, yy hex	Incremented when I&M structure is modified
<i>PROFILE_ID</i>	2 bytes	–	Defined by the PNO (3A00...3AFF)
<i>PROFILE_SPECIFIC_TYPE</i>	2 bytes	–	Profile specific number
<i>IM_VERSION</i>	2 bytes	01 hex, 02 hex	Version I&M: 1.1
<i>IM_SUPPORTED</i>	2 bytes	2E hex	Managed index I&M → I&M0, I&M1, I&M2, I&M3 and I&M5
I&M1 (index AFF1)			
<i>Tag-function</i>	32 bytes	String	Indicates the submodule's function or task
<i>Tag-location</i>	22 bytes	String	Indicates the submodule's location
I&M2 (index AFF2)			
<i>Date and time</i>	16 bytes	String	Sets the time information for the option module internally.
I&M3 (index AFF3)			
<i>Descriptor</i>	54 bytes	String	Saves local documentation specific to the option module.
I&M5 (index AFF5)			
<i>MANUFACTURER_ID</i>	2 bytes	-	Defined by the PNO same as profibus
<i>ORDER_ID (option)</i>	20 bytes	String	Commercial reference (VW3A3647)
<i>SERIAL_NUMBER (option)</i>	16 bytes	String	Unique number
<i>HARDWARE_REVISION (option)</i>	2 bytes	UInt16	Hardware revision of the option module
<i>SOFTWARE_REVISION (option)</i>	4 bytes	1 char 3 UInt8	Software version of the option module
<i>REVISION_COUNTER</i>	2 bytes	UInt16	Incremented when I&M structure is modified
<i>PROFILE_ID</i>	2 bytes	UInt16	Defined by the PNO 3A00 .. 3AFF
<i>PROFILE_SPECIFIC_TYPE</i>	2 bytes	UInt16	Profile specific code
<i>IM_VERSION</i>	2 bytes	2 UInt8	Version I&M : 1.1
<i>IM_SUPPORTED</i>	2 bytes	UInt16	1 : I&M5 supported.

Software Setup

What's in This Part

Software Overview	36
PROFINET module Basic Settings	37
Profinet module commissioning	40
S2 Redundancy	42
Most Common parameters.....	43

Software Overview

Simplified TCP/IP Model

The table provides the basic software overview according to the simplified TCP/IP model:

Application	Transport	Network	Link
PROFINET / IP services	TCP/UDP	IP	Ethernet
PROFINET RT	-	-	Ethernet

PROFINET Fieldbus Module Features Overview

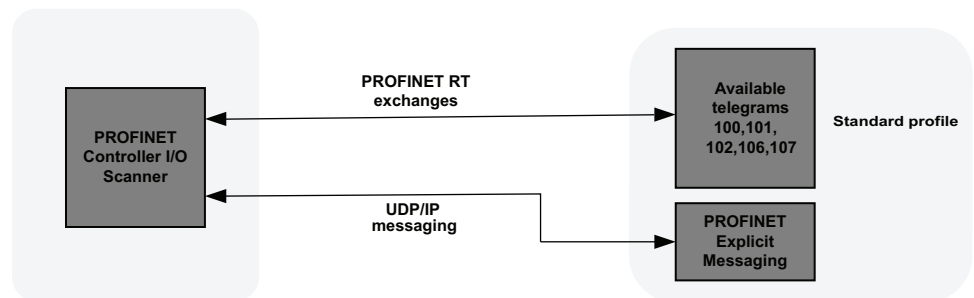

PROFINET module Basic Settings

Introduction

The parameters are described according to the display terminal.
 These settings are also possible from commissioning software.

Access

The parameters are accessible in the **[Communication]** → **[Profinet]**.

Possible Settings

The table presents the parameter settings:

HMI label	Setting	
[IP mode] <i>IPM</i>	Logic address: FBC2 hex = 64250 Factory setting: [DCP] <i>DCP</i>	Type: WORD (Enumeration) Read/write: R/W

IP mode

This parameter is used to select the IP address assignment method:



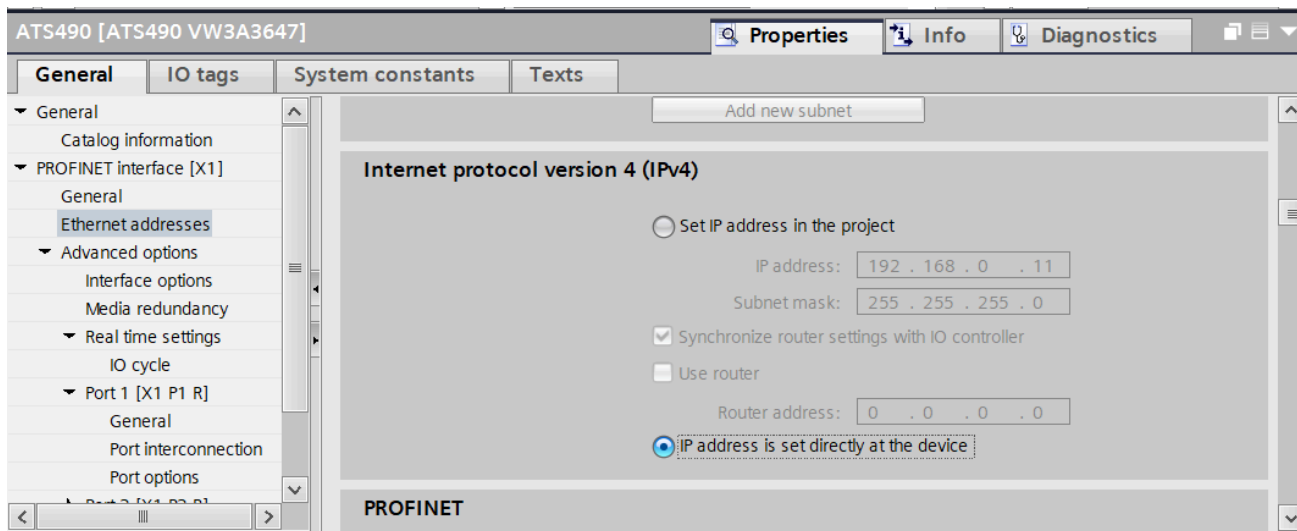

- **[Fixed]** *MANU*: Manually set the IP address.
- **[DHCP]** *DHCP*: Automatically gets the IP address from the DHCP server using the device name.
- **[DCP]** *DCP*: Automatically gets the IP address from the DCP server using the station name.

NOTE: To use **[Fixed]** *MANU* mode, select "IP address is set directly at the device".

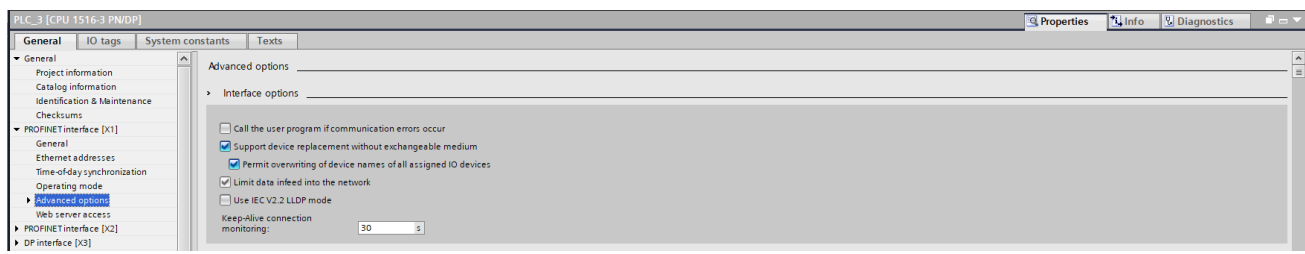

NOTE: The parameter is forced to **[DCP]** *DCP* if "Support device replacement without exchangeable medium" is selected (only available with a Siemens PLC).



HMI label	Setting	
[IP Module] IPC1, IPC2, IPC3, IPC4 [IP mode] IPM → [Fixed] MANU → 	Logic address IPC1: FAD4 hex = 64212 Logic address IPC2: FAD5 hex = 64213 Logic address IPC3: FAD6 hex = 64214 Logic address IPC4: FAD7 hex = 64215	Type: UINT (Unsigned16) Read/write: R/W
Configured Profinet IP Address This parameter is used to set the IP address and can be edited only when the IP mode is set to fixed address. The modification of this parameter setting is only effective when you restart the soft starter if [IP mode] IPM is set to [Fixed] MANU.		
[IP Mask] IPM1, IPM2, IPM3, IPM4 [IP mode] IPM → [Fixed] MANU → 	Logic address IPM1: FAD8 hex = 64216 Logic address IPM2: FAD9 hex = 64217 Logic address IPM3: FADA hex = 64218 Logic address IPM4: FADB hex = 64219	Type: UINT (Unsigned16) Read/write: R/W
Configured Profinet IP mask This parameter can be edited only when the IP mode is set to fixed address. The modification of this parameter setting is only effective when you restart the soft starter if [IP mode] IPM is set to [Fixed] MANU.		
[IP Gate] IPG1, IPG2, IPG3, IPG4 [IP mode] IPM → [Fixed] MANU → 	Logic address IPG1: FADC hex = 64220 Logic address IPG2: FADD hex = 64221 Logic address IPG3: FADE hex = 64222 Logic address IPG4: FADF hex = 64223	Type: UINT (Unsigned16) Read/write: R/W
Configured Profinet IP Gate This parameter can be edited only when the IP mode is set to fixed address. The modification of this parameter setting is only effective when you restart the soft starter if [IP mode] IPM is set to [Fixed] MANU.		
[Actual IP] IPA1, IPA2, IPA3, IPA4 [IP mode] IPM → [Fixed] MANU → 	Logic address IPA1: FAFC hex = 64252 Logic address IPA2: FAFD hex = 64253 Logic address IPA3: FAFE hex = 64254 Logic address IPA4: FAFF hex = 64255	Type: UINT (Unsigned16) Read/write: R
Actual IP Address This parameter can be accessed only when [IP mode] IPM is set to [DHCP] or to [DCP] . This is the current IP setting taken into account by the soft starter.		
[Actual mask] IPS1, IPS2, IPS3, IPS4 [IP mode] IPM → [Fixed] MANU → 	Logic address IPS1: FB00 hex = 64256 Logic address IPS2: FB01 hex = 64257 Logic address IPS3: FB02 hex = 64258 Logic address IPS4: FB03 hex = 64259	Type: UINT (Unsigned16) Read/write: R
Actual IP Mask This parameter can be accessed only when [IP mode] IPM is set to [DHCP] or to [DCP] .		

HMI label	Setting	
[Actual gate.] IPT1, IPT2, IPT3, IPT4 [IP mode] IPM → [Fixed] MANU → 	Logic address IPT1: FB04 hex = 64260 Logic address IPT2: FB05 hex = 64261 Logic address IPT3: FB06 hex = 64262 Logic address IPT4: FB07 hex = 64263	Type: UINT (Unsigned16) Read/write: R
Actual IP Gate This parameter can be accessed only when [IP mode] IPM is set to [DHCP] or to [DCP] .		
[PPO profile used] PRFL	Logic address: 1A09 hex = 6665	Type: UINT (Unsigned16) Read/write: R
PPO profile used This parameter displays the actual profile for the device. The parameter settings are: <ul style="list-style-type: none"> • [0] = UNCG / not configured • [100] = Telegram 100 • [101] = Telegram 101 • [102] = Telegram 102 • [106] = Telegram 106 • [107] = Telegram 107 		
[MAC @] MAC	Type: UINT (Unsigned16) Read/write: R	
This parameter displays the MAC address of the Profinet VW3A3647 option module.		
[Fieldbus Interrupt Resp] CLL	Logic address: 1B67 hex = 7015 Factory setting: [Freewheel Stop]	Type: WORD (Enumeration) Read/write: R/WS
Response to Fieldbus module communication interruption This parameter defines the error stop mode. <ul style="list-style-type: none"> • [Ignore] : Detected error ignored (in this case, the warning [Fieldbus Com Warn] CLLA is activated). • [Freewheel Stop] : Motor triggers in [Fieldbus Com Interrupt] CNF error and is stopped in freewheel. • [Configured Stop] : Motor is stopped according to [Type of stop] parameter. • [Deceleration] : Motor is stopped in deceleration and triggers in [Fieldbus Com Interrupt] CNF error at the end of stop. • [Braking] : Motor is stopped in dynamic braking and triggers in [Fieldbus Com Interrupt] CNF error at the end of stop. 		
⚠ WARNING		
LOSS OF CONTROL		
If this parameter is set to [Ignore] , fieldbus module communication monitoring is disabled. <ul style="list-style-type: none"> • Only use this setting after a thorough risk assessment in compliance with all regulations and standards that apply to the device and to the application. • Only use this setting for tests during commissioning. • Verify that communication monitoring has been re-enabled before completing the commissioning procedure and performing the final commissioning test. 		
Failure to follow these instructions can result in death, serious injury, or equipment damage.		

Profinet module commissioning

Assigning a station name

A station name must be defined using TIA portal or ProNeta to be in accordance with network configuration.

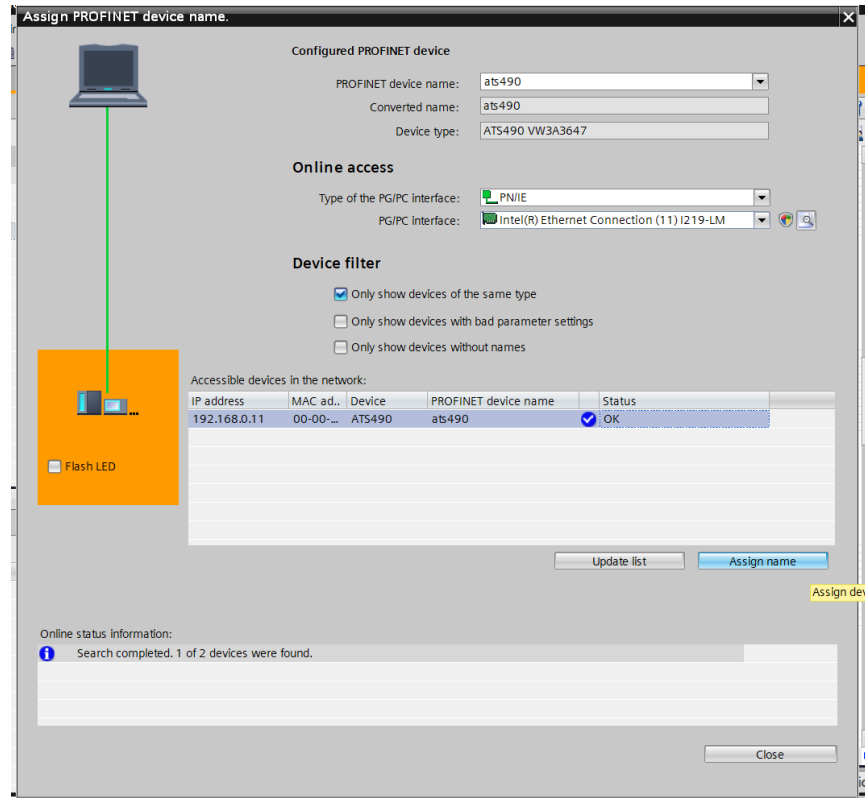

Assigning IP Parameters

The soft starter needs three IP parameters:

- The soft starter IP address.
- The subnet mask.
- The gateway IP address.

When the **[IP mode] IPM** is set to **[Fixed] MANU**, you can directly set the IP address using the graphic display terminal or using the commissioning software. The option module has a station name configured and validated via TIA portal.

When the **[IP mode] IPM** is set to **[DHCP] DHCP**, you can get IP address from a DHCP server (correspondence between the device name and the IP addresses).

When the **[IP mode] IPM** is set to **[DCP] DCP**, you can use DCP (Discovery control protocol) protocol to discover PROFINET devices. The option module has a station name configured and validated via TIA portal.

Entering IP Parameters in the Display Terminal

In the **[Communication]** → **[Profinet]** menu, enter the following IP parameters:

- **[IP address]** `IPC1`, `IPC2`, `IPC3`, `IPC4`
- **[Mask]** `IPM1`, `IPM2`, `IPM3`, `IPM4`
- **[Gateway]** `IPG1`, `IPG2`, `IPG3`, `IPG4`

Turn off the soft starter and then back on again (control voltage if a separate power supply is being used), otherwise the IP parameters are not taken into account.

The new IP address is immediately displayed but will only be effective the next time the soft starter is turned on.

Case of Manual Switching of [IP mode] `IPM`

When switching **[IP mode]** `IPM` to **[DCP]** `DCP`

- IP settings are no longer editable
- Turn off the soft starter supply and then back on again, including the control voltage if a separate power supply is being used
- The new configuration is applied, the device is waiting for IP settings from the PROFINET controller

When switching **[IP mode]** `IPM` to **[Fixed]** `MANU`

- IP settings become editable
- Set IP settings with valid values
- Turn off the soft starter and then back on again, including the control voltage if a separate power supply is being used
- The new configuration is applied

When switching **[IP mode]** `IPM` to **[DHCP]** `DHCP`

- IP settings are no longer editable.
- Set the device name with a valid value.
- Turn off the soft starter and then back on again, including the control voltage if a separate power supply is being used.
- The new configuration is applied, the device is waiting for IP settings from DHCP server.

Case of Automatic Switching of [IP mode] `IPM` to [DCP] `DCP`

The following condition should be fulfilled:

- The option module has a station name configured and validated.
- The device is connected to a PROFINET controller.
- The PROFINET controller has the station name in its own configuration. This station name is the same as the option module's.
- The settings are in local configuration of the PROFINET controller.

If the all above mentioned conditions are fulfilled:

- **[IP mode]** `IPM` is automatically set to **[DCP]** `DCP`
- IP settings are replaced by the one set in local PROFINET controller
- The new configuration is applied immediately

S2 Redundancy

Description

System redundancy S2 defines the concept of establishing multiple connections to a device to ensure continuous system operation in case of a communication connection interruption. The S2 redundancy functionality, integrated into the VW3A3647 option module through the GSDML file, enables two controllers, one primary and one backup, to connect to the device.

- When the primary controller is unavailable, the backup controller seamlessly takes over communication without any disruption to the network.
- Both controllers use the same configuration (submodule configuration)

Network topology

The profinet devices (soft starter + VW3A3647 option module) supporting the S2 redundancy functionality can be paired to:

- R-system with S2 redundancy: the synchronization between the two controllers is done via Profinet ring. The Profinet devices are connected to the controllers in a MRP ring structure.

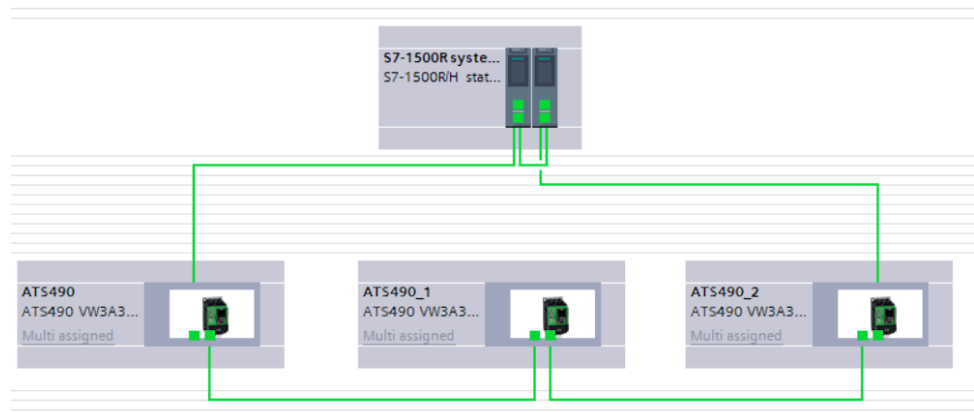

- H-system with S2 redundancy: the synchronization between the two controllers is done via the fiber optical.

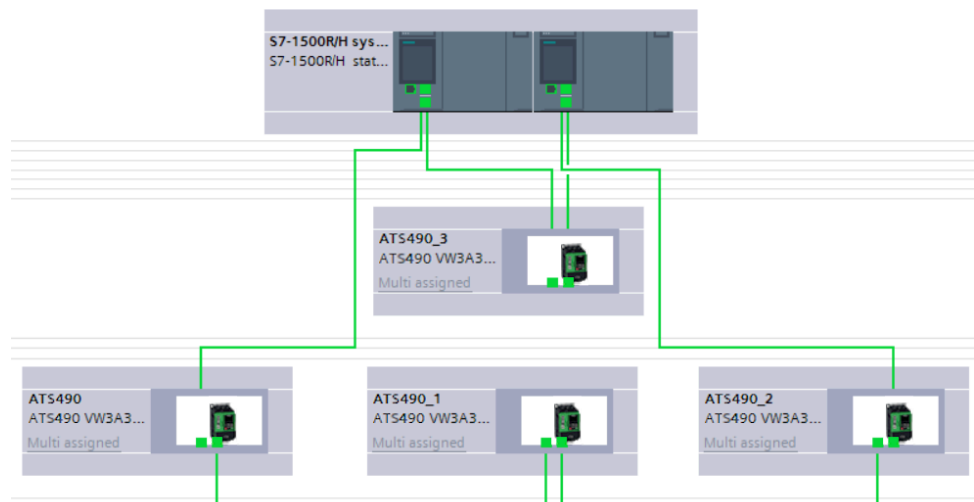

Most Common parameters

For more information about the Communication Parameter Addresses, please refer to the ATS490 Communication Parameter Addresses, page 14.

NOTE: Cannot write cyclically configuration parameters (as the device can remain in **[Freewheel]** *NST*) tagged by R/WS.

Base Monitoring

Code	Settings	
[Motor Current] <i>LCR</i>	Logic address: 0C84 hex = 3204	Type: UINT (Unsigned16) Read/write: R Unit: 0.1 A. or 1 A according to the soft starter rating.
Motor current RMS Motor current. Average of the three line currents based on the measurement of the fundamental of the motor line currents.		
[Motor Therm State] <i>THR</i>	Logic address: 259E hex = 9630	Type: UINT (Unsigned16) Read/write: R Unit: 1 %
Motor thermal state This parameter monitors the motor thermal state. 100% corresponds to the nominal thermal state at the nominal motor current set to [Motor Nom Current] .		
[Motor Run Time] <i>RTH</i> via communication	Logic address: 0CAC hex = 3244	Type: UINT (Unsigned32) Read/write: R Unit: 1 s
Motor run time This parameter monitors how long the motor has been energized.		
[Motor Run Time] <i>RTHH</i> via Display Terminal	Logic address: 0CCA hex = 3274	Type: UINT (Unsigned32) Read/write: R/WS Unit: 1 s
Motor run time This parameter monitors how long the motor has been energized.		
[Elc Energy Cons] <i>OCK</i>	Logic address: 299C hex = 10652	Type: UINT (Unsigned32) Read/write: R Unit: kWh
Electrical energy consumed by the motor (kWh) This parameter monitors how much energy consumed by the motor in kWh.		

Digital I/O

Code	Settings	
[Logic Inputs States] IL1R	Logic address: 1452 hex = 5202	Type: WORD (BitString16) Read/write: R Unit: -
<p>Logic inputs states This parameter is used to monitor the real value of the [Logic Inputs States].</p> <ul style="list-style-type: none"> • Bit0 : "DI1" Digital inputs real image • Bit1 : "DI2" Digital inputs real image • Bit2 : "DI3" Digital inputs real image • Bit3 : "DI4" Digital inputs real image <p>NOTE: The status of inputs can be read via [Logic Inputs States] IL1R to which a position or level sensor has been wired.</p>		
[Logic Outputs States] OL1R	Logic address: 145C hex = 5212	Type: WORD (BitString16) Read/write: R/W Unit: -
<p>Logic outputs states This parameter is used to write output value or monitor the value depending on if a function is assigned to the corresponding output:</p> <ul style="list-style-type: none"> • Bit0 : "R1" relay real image • Bit1 : "R2" relay real image • Bit2 : "R3" relay real image • Bit8 : "DQ1" Digital outputs real image • Bit9 : "DQ2" Digital outputs real image <p>NOTE: To write an output through communication, no function should be assigned to the corresponding output. Otherwise, writing on the bit linked to the corresponding output has no impact. If an error is triggered, outputs written through communication returns to 0.</p> <p>NOTE: It is only possible to write the output through the active command channel. Consequently, forced outputs can not be disabled on local channel (such as display terminal).</p>		

Analog input

The following diagram explains how the analog input works:

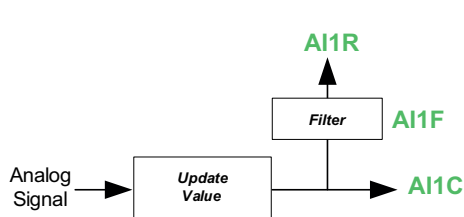

- AI1C [AI1]
- AI1F [AI1 filter]
- AI1R [Analog Input 1 Standardized Value]

Code	Settings	
[AI1] AI1C	Logic address: 147A hex = 5242	Type: INT (Signed16) Read/write: R Unit: -
<p>Physical value AI1 This parameter is used to monitor the real value of the [AI1].</p> <ul style="list-style-type: none"> • [PTC] (0.01kOhm) • [KTY] (1 Ohm) • [PT100]: PT100 (0.1 Ohm) • [PT100 in 3 wires]: PT100 in 3 wires (0.1 Ohm) • [PT1000]: PT1000 (1 Ohm) • [PT1000 in 3 wires]: PT1000 in 3 wires (1 Ohm) 		
 [AI1 filter] AI1F	<p>Setting range: 0...10 s</p> <p>Factory setting: 0 s</p> <p>Logic address: 1164 hex= 4452</p>	Type: UINT (Signed16) Read/write: R/W Unit: seconds
<p>AI1 filter This parameter sets the cutoff time of the low filter for PTC1/AI1. The low pass filter aims to suppress electrical noise and avoid interference issue in the input signal.</p>		
[Analog Input 1 Standardized Value] AI1R	Logic address: 1470 hex= 5232	Type: INT (Signed16) Read/write: R Unit: -
<p>Analog input 1 standardized value Real image of AI1 consumed by functions.</p>		

Analog outputs

The analog outputs can be controlled via the network. Simply write these parameters. The outputs to be controlled must not be assigned to a function, otherwise the write operation has no effect.

NOTE: To write an output through communication, no function should be assigned to the corresponding output. Otherwise, writing on the register linked to the corresponding output has no impact. If an error is triggered, outputs written through communication returns to 0.

NOTE: It is only possible to write the output through the active command channel. Consequently, forced outputs can not be disabled on local channel (such as display terminal).

The following diagram explains how the analog output works:

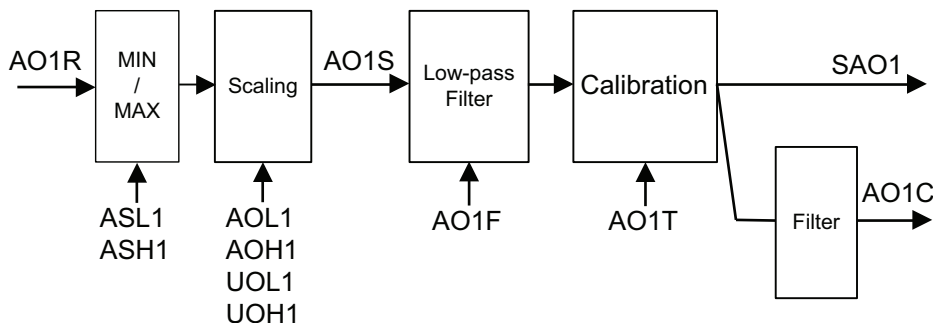

- AO1R [Analog Output 1 Standardized Value]
- ASL1 [Scaling AQ1 Min]
- ASH1 [Scaling AQ1 Max]
- AOL1 [AQ1 min output]
- AOH1 [AQ1 max output]
- UOL1 [AQ1 min Output]
- UOH1 [AQ1 max Output]
- AO1S [AQ1 Scaling]
- AO1F [AQ1 Filter]
- AO1T [AQ1 Type] : is too select between mA and V.
- SAO1 [AO1 Physical Value Without Filter]
- AO1C [AQ1]

Code	Settings	
[Analog Output 1 Standardized Value] AO1R	Logic address: 148D hex = 5261	Type: INT (Signed16) Read/write: R/W Unit: -
<p>Analog output 1 standardized value This parameter is used to read and write a value on AO1. Real image of AO1 consumed by functions.</p>		
[AQ1] AO1C	Logic address: 1497 hex = 5271	Type: INT (Signed16) Read/write: R/W Unit: -
<p>AQ1 physical value This parameter is used to read and write a value, readable on display terminal.</p>		

Operation

What's in This Part

Profile.....	48
Functional Profiles Supported by the Altivar Soft Starter	49
Command Channel	50
Command Register and Status — [Standard Profile]	52
I/O Profile	59
Extended Control Word and Internal State register in [Standard Profile] & [I/O Profile].....	63
Starting Sequence.....	66
Description Telegram 100, 101, 102, 106, 107	72
Configuring the soft starter with TIA Portal.....	76
Configuration of a soft starter with the Telegram 100	77
Configuring a soft starter with the Telegram 101, 102, 106, or 107	78
Parameters Management with the Telegram 100, 101, 102, 106, 107	79
Identification and Maintenance Data	80
Soft Starter Parameters Access Channel	81
Monitoring of Communication Channel.....	86

Profile

There are 3 types of profile:

- Communication profiles
- Functional profiles
- Application profiles

Communication Profile

A communication profile describes the characteristics of a bus or network:

- Cables
- Connectors
- Electrical characteristics
- Access protocol
- Addressing system
- Periodic exchange service
- Messaging service
- ...

A communication profile is unique to a type of fieldbus (such as Modbus, PROFIBUS DP, and so on) and is used by different types of devices.

Functional Profile

A functional profile describes the behavior of a type of device:

- Functions
- Parameters (such as name, format, unit, type, and so on.)
- Periodic I/O variables
- State chart
- ...

Application Profile

Application profile defines the services to be provided by the devices on a machine.

Interchangeability

The aim of communication and functional profiles is to achieve interchangeability of the devices connected via the fieldbus.

Functional Profiles Supported by the Altivar Soft Starter

Two functional profiles are supported by the Altivar Soft Starter:

- Standard Profile via **[Control Mode]** set to **[Standard Profile]**.
- I/O Profile via **[Control Mode]** set to **[I/O profile]**.

Standard Profile

The Standard Profile supported by the Altivar Soft Starter is based on the CiA402, which has been adapted to the characteristics of the Altivar Soft Starter and therefore to all communication ports.

5 bits of the control word (bits 11...15) can be assigned to a function.

NOTE:

- Altivar Soft Starter starts up following a command sequence
- After switching on and when an operating mode is started, Altivar Soft Starter goes through several operating states

I/O Profile

This profile supported by all channel commands. It mirrors the use of the terminal by allowing to use 1 bit of command register to activate a function.

- I/O profile can also be used when controlling via a fieldbus.
- N bits of **Command register** can be assigned to a specific function.
 - N from 1 to 15 if 2 wires control
 - N from 2 to 15 if 3 wires control.
- **Status Register** is standardized as **[Standard Profile]**.
- According to command sent via **Command register** to operating states diagram, a **Status Register** is updated.

Configuration of the Soft starter command channel according to the selected Profile

This section describes how to configure the command channel settings of the soft starter.

In order to switch in **[Standard Profile]**, **[Expert]** level access should be configured.

The active command channel is then defined by CD1 or CD2 according to **[Command Switching]** (expected if forced local feature is used).

NOTE: for more information about **[Forced Local Assign]** and **[HMI L/R cmd]**, refer to the user manual.

Command Channel

In the **[Complete settings]** menu, **[Command channel]** submenu the user can set the following value to **[Cmd channel 1]** and **[Cmd channel 2]**:

- Terminal board.
- Graphic display terminal.
- Embedded Modbus RTU.
- CANopen option module.
- Other fieldbus option module.
- Embedded Ethernet.

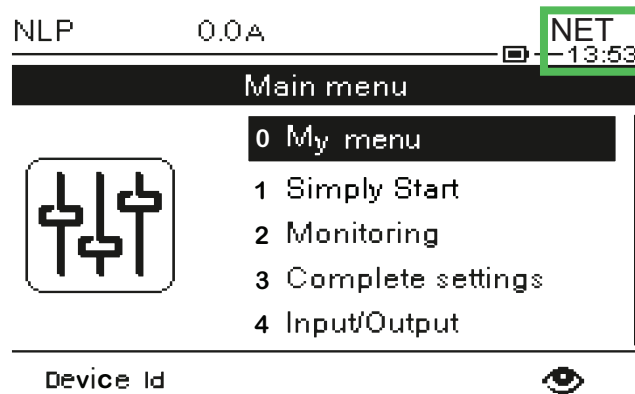

NOTE: To command through PROFINET fieldbus, set the command channel parameter to **[Com. Module] NET**.

On the right-top of the graphic display terminal screen, the information of the active command is displayed:



With **[Command Switching]**, user chooses which channel takes the command of the device by switching between **[Cmd channel 1]** and **[Cmd channel 2]**.

Access path: **[Complete settings]** → **[Command channel]**

Code	Settings	
[Command Switching] 	Logic address: 20E5 = 8421	Type: WORD (Enumeration) Read/write: R/WS
Command switching		
<h2 style="margin: 0;">⚠ WARNING</h2> <p style="margin: 0;">UNANTICIPATED EQUIPMENT OPERATION</p> <p style="margin: 0;">This parameter can cause unintended movements, for example, inversion of the direction of rotation of the motor, sudden acceleration or stops.</p> <ul style="list-style-type: none"> • Verify that the setting of this parameter does not cause unintended movements. • Verify that the setting of this parameter does not result in unsafe conditions. <p style="margin: 0;">Failure to follow these instructions can result in death, serious injury, or equipment damage.</p>		
<p>This parameter sets which channel takes the command of the soft starter.</p> <ul style="list-style-type: none"> • [Cmd channel 1]: Channel 1 is the command channel (in this case, switching between [Cmd channel 1] and [Cmd channel 2] is not possible). • [Cmd channel 2]: Channel 2 is the command channel (in this case, switching between [Cmd channel 1] and [Cmd channel 2] is not possible). • [DI•]: Command channel switching assigned to digital input. • [Cy••]: Command channel switching assigned to line channel. <p style="margin-left: 20px;">NOTE: PROFINet fieldbus, use [C3••].</p> <p>When assigned to a digital input:</p> <ul style="list-style-type: none"> • [Cmd channel 1] active at low level. • [Cmd channel 2] active at high level. 		
[Active Command Channel] 	Logic address: 20FA = 8442	Type: WORD (BitString16) Read/write: R
<p>Active command channel</p> <p>Reading this value allows to monitor which is the active command channel who is controlling the device.</p> <ul style="list-style-type: none"> • Bit0 = 1 : Terminal board. • Bit2 = 1 : Display Terminal. • Bit3 = 1 : Embedded Modbus RTU. • Bit6 = 1 : CANopen option module. • Bit9 = 1 : Other fieldbus option module. • Bit11 = 1 : Embedded Ethernet. • Bit15 = 1 : SoMove (via control panel). 		

Command Register and Status — [Standard Profile]

What's in This Chapter

Functional Description	53
Operating State Diagram in [Standard Profile]	53
Device Status Summary	55
Description of Operating States in [Standard Profile]	55
Command Register in [Standard Profile]	56
Status Word	57
Stop and Halt Commands	58

Functional Description

Introduction

Soft starter operation involves one main function, which is illustrated in the diagrams below.

Altivar Soft Starter

The following figure shows the control diagram for soft starter operation:

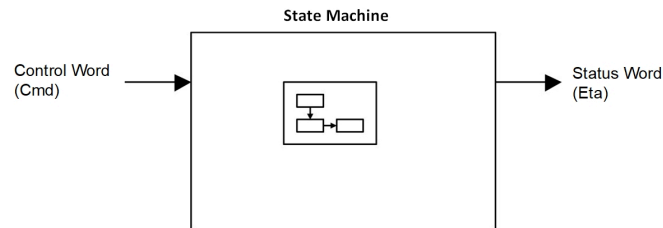

Operating State Diagram in [Standard Profile]

After switching on and when an operating mode is started, the product goes through a number of operating states.

The state diagram (state machine) shows the relationships between the operating states and the state transitions. The operating states are internally monitored and influenced by monitoring functions.

The following figure shows the [Standard Profile] state diagram:

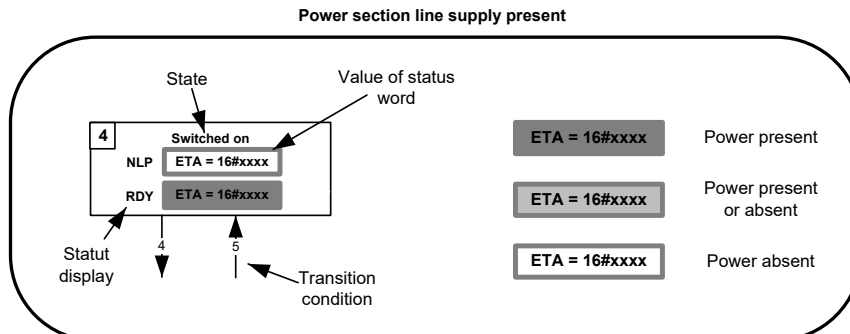
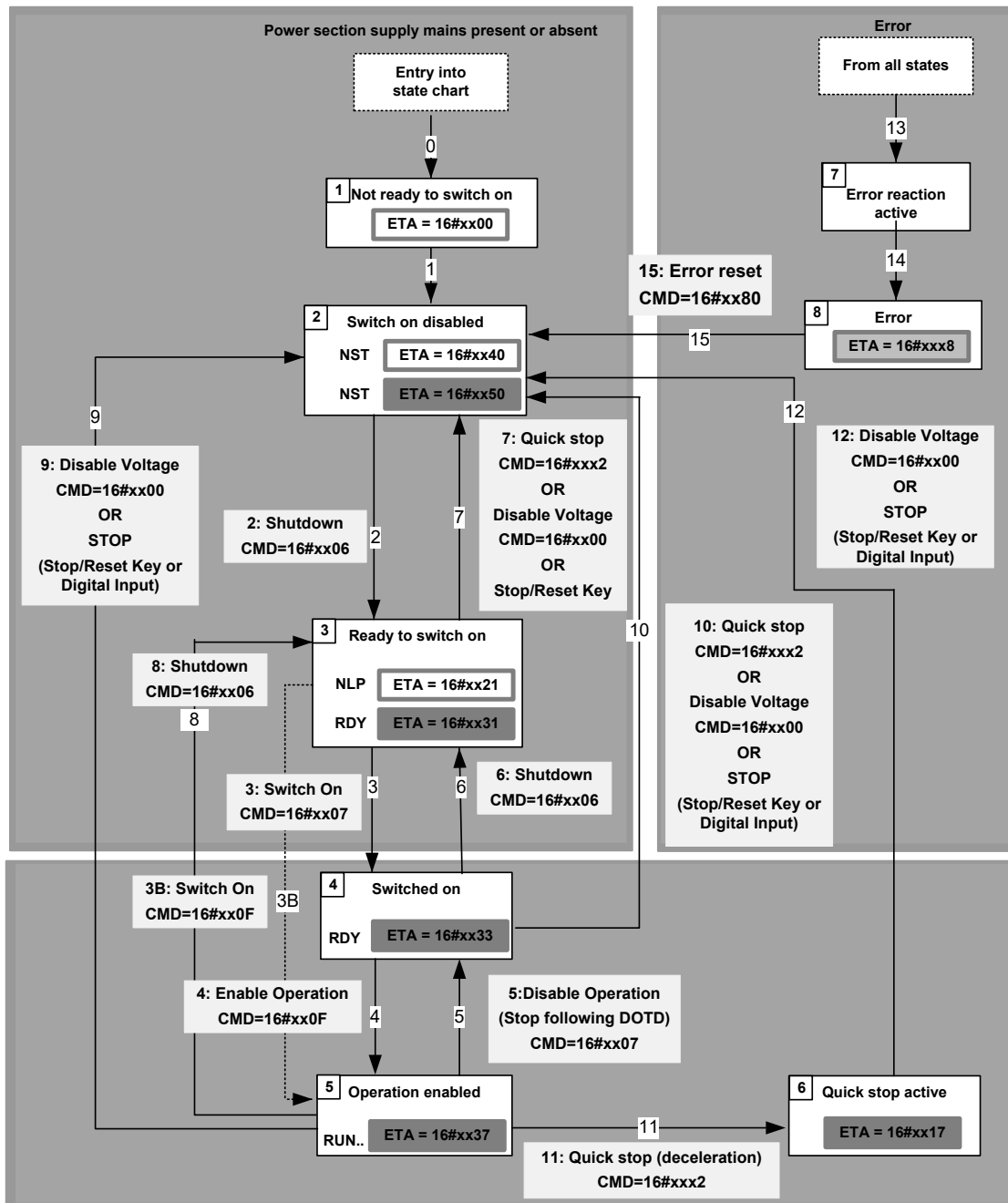

NOTE: The transition 3B is possible but not included in the CIA402 operating state diagram.

Device Status Summary

Operating State	Power Supply to Power Stage	Power Supplied to Motor	Modification of Configuration Parameters
1 - Not ready to switch on	Not required	No	Yes
2 - Switch on disabled	Not required	No	Yes
3 - Ready to switch on	Not required	No	Yes
4 - Switched on	Required	No	Yes
5 - Operation enabled	Required	Yes	No
6 - Quick stop active	Required	Yes, during deceleration	No
7 - Fault reaction active	Depends on error response configuration	Depends on error response configuration	No
8 - Fault	Not required	No	Yes

NOTE:

- Configuration parameters are described in communication parameter file as R/WS access type parameters.
- An adjustment parameter can be accessed in all operating state of the soft starter.

Description of Operating States in [Standard Profile]

Each state represents an internal reaction by the soft starter.

The operating state of the soft starter changes depending on whether the control word is sent to **[Cmd Register] CMD** or an event occurs (an error detection, for example).

The soft starter operating state can be identified by the value of the status word **[Status Register] ETA**. For more information, refer to the **[Status Register] ETA** chapter.

Operating State	Description
1 - Not ready to switch on	<ul style="list-style-type: none"> • Initialization starts. This is a transient state invisible to the communication network.
2 - Switch on disabled	<ul style="list-style-type: none"> • The power stage L1/L2/L3 is not ready to switch on. • The control stage A1/A2 must be supplied to set the configuration and adjustment parameters. • The soft starter is locked, no power is supplied to the motor.
3 - Ready to switch on	<ul style="list-style-type: none"> • The power stage L1/L2/L3 is ready to switch on. • With the control stage A1/A2 supplied, it is not necessary to supply the power stage, but the system expects it in order to change to state 4 - Switched on • The soft starter is locked, no power is supplied to the motor. • The configuration and adjustment parameters can be modified.
4 - Switched on	<ul style="list-style-type: none"> • Power stage is switched on. • The power stage of the soft starter is ready to operate, but voltage has not yet been applied to the output. • The adjustment parameters can be modified. <p>NOTE: By default, Relay R1 [R1 Assignment] is set to [Operating State Fault] then the mains contactor is closed. The soft starter is locked, no power is supplied to the motor.</p> <p>NOTE: If mains contactor is wired on a relay ([R1 Assignment], [R2 Assignment] or [R3 Assignment] is set to [Mains Contactor]), we reach temporarily this state once Run command is applied and mains contactor is closed allowing presence of power stage before switching to 5 - Operation enabled.</p> <p>For more information about Starting sequence, refer to Starting Sequence, page 66.</p>

Operating State	Description
5 - Operation enabled	<ul style="list-style-type: none"> Power stage is enabled. The soft starter is in running state. For a separate control stage with mains contactor, the contactor is closed. The soft starter is unlocked, power is supplied to the motor. The soft starter functions are activated and voltage is applied to the motor terminals. If the <code>Halt</code> command is applied, no power is supplied to the motor expect in preheating. The adjustment parameters can be modified. The configuration parameters cannot be modified. From this state the reaction of the soft starter to a <code>Disable operation</code> command depends on the value of the <code>[SwitchOnDisable Stp] DOTD</code> parameter: <ul style="list-style-type: none"> If the <code>[SwitchOnDisable Stp] DOTD</code> parameter is set to 0, the soft starter changes to operating state 4 - <i>Switched on</i> and stops in freewheel stop. If the <code>[SwitchOnDisable Stp] DOTD</code> parameter is set to 1, the soft starter stops following to the and then changes to operating state 4 - <i>Switched on</i>.
6 - Quick stop active	<ul style="list-style-type: none"> The soft starter performs a deceleration ramp. After the motor has stopped, the soft starter switches to state 2 - <i>Switch on disabled</i>.
7 - Fault reaction active	<ul style="list-style-type: none"> Transient state during which the soft starter performs a stop due to a detected error. If behavior of the detected error is configurable, then the reaction will depend on setting of its error response.
8 - Fault	<ul style="list-style-type: none"> End of the stop caused by change to the previous state 7 - <i>Fault reaction active</i>. Power stage is disabled. The soft starter is locked, no power is supplied to the motor if an error detection has been triggered. Else the soft starter change to the step 2- <i>switch on disable</i>. The soft starter function is disabled.

Command Register in [Standard Profile]

[Cmd Register] is used to control the product defined as followed:

	Bit 0	Bit 1	Bit 2	Bit 3	Bit 4	Bit 5	Bit 6	Bit 7
Function	Switch	Enable / Disable voltage	Quick Stop	Operation Run command	Reserved			Error reset request
Bit at 0	Off.	Disable.	Activate.	Disable.				Active on rising edge.
Bit at 1	On.	Enable.	Deactivate.	Enable.				

	Bit 8	Bit 9	Bit 10	Bit 11	Bit 12	Bit 13	Bit 14	Bit 15
Function	Halt command	Reserved		Reverse Direction request (1) NOTE: for more information about Reverse function, refer to the user manual.	Manufacturer specific assignable	Dynamic braking stop (1)	Decelerated stop order (1)	Manufacturer specific assignable
Bit at 0	Request not sent.			Deactivate.		Deactivate.	Deactivate.	
Bit at 1	Stop following [Type of stop].			Activate.		Activate.	Activate.	

(1) The Bit can be set to an other function (factory setting).
NOTE: If no function is assigned, the Bit will return to his factory setting.

Bit Mapping of the Control Word

Command	State Transition	Final Operating State	Bit 7	Bit 3	Bit 2	Bit 1	Bit 0	Example Value
			Fault Reset	Enable Operation	Quick Stop	Enable Voltage	Switch On	
<i>Shutdown</i>	2, 6, 8	3 - Ready to switch on	X	X	1	1	0	0006 hex
<i>Switch on</i>	3	4 - Switched on	X	X	1	1	1	0007 hex
<i>Enable operation</i>	4	5 - Operation enabled	X	1	1	1	1	000F hex
<i>Disable operation</i>	5	4 - Switched on	X	0	1	1	1	0007 hex
<i>Disable voltage</i>	7, 9, 10, 12	2 - Switch on disabled	X	X	X	0	X	0000 hex
<i>Quick stop</i>	7, 10, 11	6 - Quick stop active	X	X	0	1	X	0002 hex
<i>Fault reset</i>	15	2 - Switch on disabled	0 → 1	X	X	X	X	0080 hex

X: Value is of no significance for this command.
 0→1: Command on rising edge.

Status Word

[Status Register] is used to gives status register as followed:

Code	Settings
[Status Register] <i>ETA</i>	Logic address: 0C81 hex = 3201 Type: WORD (BitString16) Read/write: R Unit: -
Status Register	

	Bit 0	Bit 1	Bit 2	Bit 3	Bit 4	Bit 5	Bit 6	Bit 7
Function	<i>Ready to Switch on</i>	<i>Switched on</i>	<i>Operation enabled Running</i>	<i>Detected error</i>	<i>Voltage enabled</i>	<i>Quick stop</i>	<i>Switch on disabled</i>	<i>Warning</i>
Bit at 0	Not ready.	Not ready.	Not running.	No error.	Power stage supply absent.	Active.	Not active. Power section line supply opened.	No warning.
Bit at 1	Ready.	Ready.	Running.	Error is present.	Power stage supply present.	Not active.	Active. Power section line supply locked.	Warning is present.

	Bit 8	Bit 9	Bit 10	Bit 11	Bit 12	Bit 13	Bit 14	Bit 15
Function	Reserved	<i>Local channel active</i>	Reserved				Stop imposed by STOP key on graphic display terminal	<i>Direction</i>
Bit at 0		Active.					Activate.	Forward.
Bit at 1		Not active.					Deactivate.	Reverse.

Bit Mapping of the Status Word

Operating State	Bit 6	Bit 5	Bit 4	Bit 3	Bit 2	Bit 1	Bit 0	ETA Masked by 006F H ⁽¹⁾
	Switch On Disabled	Quick Stop	Voltage Enabled	Fault	Operation Enabled	Switched On	Ready to Switch On	
2 -Switch on disabled	1	0	X	0	0	0	0	0040 hex 0050 hex
3 -Ready to switch on	0	1	X	0	0	0	1	0021 hex 0031 hex
4 -Switched on	0	1	1	0	0	1	1	0033 hex
5 -Operation enabled	0	0	1	0	1	1	1	0037 hex
6 -Quick stop active	0	0	1	0	1	1	1	0017 hex
8 -Fault	X	X	X	1	0	0	0	xxx8 hex ⁽²⁾ ... xx28 hex

⁽¹⁾ This mask can be used by the PLC program to test the diagram state.

⁽²⁾ Detected error following operating state 6 - *Quick stop active*.

X: In this state, the value of the bit can be 0 or 1.

Stop and Halt Commands

BIT 13 and BIT 14 of Command register

Only available if [Control Mode] is set to [Standard Profile]. When **dynamic braking stop** or **decelerated stop order** is activated, the soft starter performs a **braked stop** or a **decelerated stop** and remains locked in the operating state 5 - *Operation enabled*.

BIT 8 : Halt command

Only available if [Control Mode] is set to [Standard Profile]. The `Halt` command enables movement to be interrupted without having to leave the 5 - *Operation enabled* state. The stop is performed in accordance with the [Type of stop] `STT` parameter.

If the `Halt` command is active, no power is supplied to the motor and no torque is applied.

I/O Profile

I/O Profile via **[Control Mode]** is set to **[I/O profile]**.

As well as physical digital inputs commanding the soft starter in terminal command, the soft starter can be commanded by line channel and each bit of the control word can be assigned to a dedicated function if the bit is free. **[I/O profile]** makes it possible to go from 4 physical digital inputs to 16 virtual digital inputs.

NOTE: The customer must monitor the **[Device State]** **HMISS**.

NOTE: When communication is used to control the soft starter and **[2/3-Wire Control]** is set to **[3-Wire Control]** / **[Hardwired ctrl mode]**, DI1 must be connected to the +24V

Code	Settings	
[Cmd Register] <small>CMD</small>	Logic address: 2135 hex = 8501	Type: WORD (BitString16) Read/write: R/W
<p>Command register If the [2/3-Wire Control] parameter is set to :</p> <ul style="list-style-type: none"> [2-Wire Control], the Command register bits are: <ul style="list-style-type: none"> Bit0 : Run enable + Forward Direction Bit1 to Bit15 : Free [3-Wire Control] / [Hardwired ctrl mode] , the Command register bits are: <ul style="list-style-type: none"> Bit0 : Run enable Bit1 : Forward Direction Bit2 to Bit15 : Free 		

A function input can be assigned to:

- A virtual input (Cd00 to Cd15) according to the active command channel, corresponding bit of the control word or digital input of the terminal must be used to activate / deactivate the function.
- A terminal input (DI1 to DI4) irrespective of the active command channel, the function can be activated / deactivated using the corresponding digital input (exception for some function that requires to have the terminal as active command channel to activate / deactivate the function).

The function **[Command Switching]** can be activated / deactivated, irrespective of the active command channel, using the corresponding bit of a terminal input or of the control word **[Cy●●]**:

- A modbus control word (**[C100]** to **[C115]**)
- A CANopen control word (**[C200]** to **[C215]**).
- A fieldbus module, such as PROFIBUS or PROFINET, control word (**[C300]** to **[C315]**).
- An embedded ethernet control word (**[C500]** to **[C515]**)

Bit	Fixed assignments		
	Virtual Inputs	Terminals	Profinet
bit 0	Cd00	DI1	C300
bit 1	Cd01	DI2	C301
bit 2	Cd02	DI3	C302
bit 3	Cd03	DI4	C303
bit 4	Cd04	-	C304
bit 5	Cd05	-	C305
bit 6	Cd06	-	C306
bit 7	Cd07	-	C307

Bit	Fixed assignments		
	Virtual Inputs	Terminals	Profinet
bit 8	Cd08	-	C308
bit 9	Cd09	-	C309
bit 10	Cd10	-	C310
bit 11	Cd11	-	C311
bit 12	Cd12	-	C312
bit 13	Cd13	-	C313
bit 14	Cd14	-	C314
bit 15	Cd15	-	C315

Switched assignment

When **[Control Mode]** is set to **[I/O profile]**, the transition of the active command channel to fieldbus does not follow the configuration of the parameters **[2/3-Wire Control]** and **[2-wire type]**. An immediate start will be observed if a run command is active on the **[Cmd Register]** *CMD*.

⚠ WARNING

UNANTICIPATED EQUIPMENT OPERATION

- Verify that this behavior does not result in unsafe conditions by performing extensive commissioning tests.
- If the start on transition is not desired, the bits corresponding to the run command must always be reset before switching the active command channel to fieldbus.

Failure to follow these instructions can result in death, serious injury, or equipment damage.

Example with:

- **[Command Switching]** managed by digital input.
- A function assigned to a switched bit (here **CD02**).
- B function assigned to a digital input (here **DI4**).
- **[Cmd channel 1] = [Com. Module]**.
- **[Cmd channel 2] = [Terminal]**.

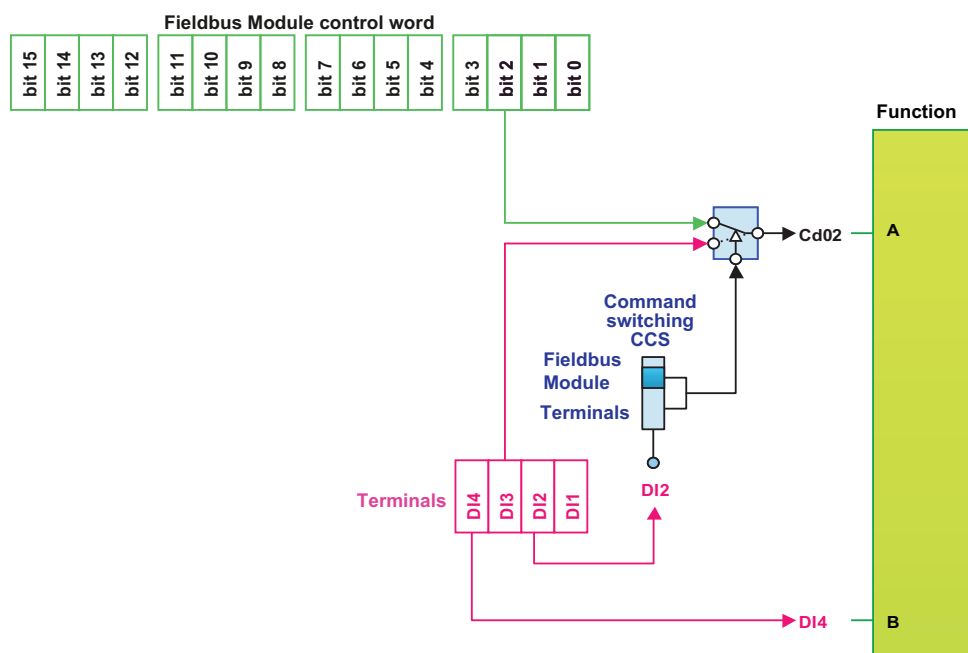

Example with:

- **[Command Switching]** managed by control word (here **C305**).
- A function assigned to a switched bit (here **CD02**).
- B function assigned to a digital input (here **DI4**).
- **[Cmd channel 1] = [Com. Module]**.
- **[Cmd channel 2] = [Terminal]**.

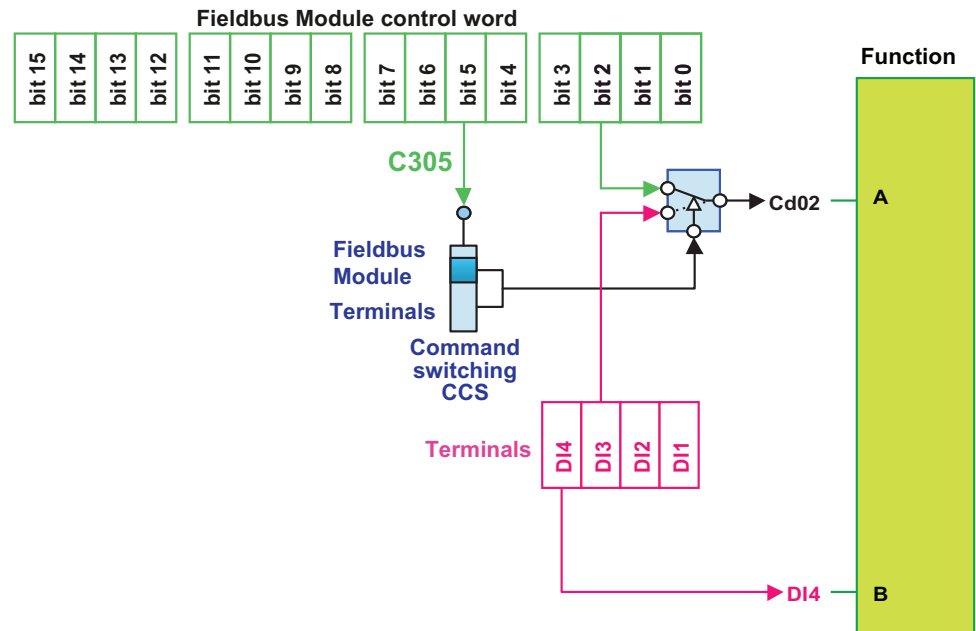

When a function is assigned to a switched bit (Cd00 to Cd15), the function can be activated via Terminals or selected communication channel according to the active command channel. To switch between Terminals and communication modules, use **[Command Switching]** function.

NOTE: A single function can be assigned to a bit at the same time, here as **[C305]** is assigned to **[Command Switching]**, Cd05 cannot be assigned to another function.

Exemple: I/O profile with monitoring of tank by flow sensors

In this example, a PLC is used to monitor the water level in a tank.

The soft starter is used to manage some functions as anti-jam.

The PLC and the soft starter are connected via a PROFINET network. The PLC controls the operation of the installation via the PROFINET bus.

Configuration

- **[Control Mode]** is set to **[I/O profile]**.
- **[2/3-Wire Control]** set to **[2-Wire Control]**.
- **[Reverse Assign]** set to **[CD01]**
- **[Fault Reset Assign]** set to **[CD05]**
- **[Ext Anti-Jam Trigger]** set to **[CD06]**.
- **[Cmd channel 1]** set to **[Com. Module]**.

Configuration schematic diagram:

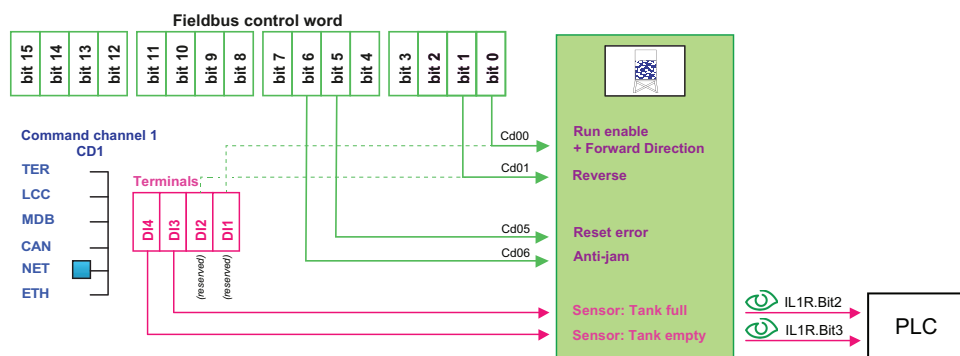

NOTE: Some digital inputs are reserved because bits are already assigned.

In our example:

- Cd00 is assigned to **Run enable + Forward direction**.
- Cd01 is assigned to **Reverse**.

➔ DI1 and DI2 cannot be assigned.

Extended Control Word and Internal State register in [Standard Profile] & [I/O Profile]

What's in This Chapter

Extended Control Word.....	64
Internal State register	65

Extended Control Word

When a configuration parameter is modified by fieldbus, it is not stored automatically in the EEPROM. The value will be lost after a power cycle if the request to store the new configuration has not been done.

⚠ WARNING
LOSS OF PARAMETER CONFIGURATION AFTER A POWER CYCLE
Bit 1 of [Extended Control Word] CMI must be written at 1 each time the configuration is modified by fieldbus.
Failure to follow these instructions can result in death, serious injury, or equipment damage.

NOTE: Do not write [Extended Control Word] BITs cyclically (especially BIT 1), as this may damage the EEPROM.

[Extended Control Word] is used to control the product defined as followed:

Code	Settings	
[Extended Control Word] CMI	Logic address: 2138 hex = 8504	Type: WORD (BitString16) Read/write: R/W Unit: -
<i>Extended control word</i>		

	Bit 0	Bit 1	Bit 2	Bit 3	Bit 4	Bit 5	Bit 6	Bit 7
Function	<i>Restore factory settings</i>	<i>Store customer parameters</i>	<i>Restore saved customer parameters</i>	<i>External error</i>	Reserved			
Bit at 0	Active on rising edge when motor is powered off.	Active on rising edge.	Active on rising edge when motor is powered off. Once request is considered, this bit is automatically reset.	Active on rising edge.				
Bit at 1	Once request is considered, this bit is automatically reset.	Once request is considered, this bit is automatically reset.						

	Bit 8	Bit 9	Bit 10	Bit 11	Bit 12 In [Standard Profile]:	Bit 12 In [I/O profile]:	Bit 13	Bit 14	Bit 15
Function	Reserved				<i>Reverse direction request</i>	Reserved	<i>Lock device when motor stopped</i>	Reserved (must always be set to 0).	<i>Disable parameter consistency check</i>
Bit at 0					Request not sent.		Deactivate.		All parameters are validated.
Bit at 1					Request sent. Motor can start in reverse direction (only if CMD bit 11 is assigned to specific function other than reverse).		Activate.		No check of parameter consistency and device is locked when stopped.

Internal State register

[Internal State Reg] is used to gives the extended internal status register as followed:

Code	Settings	
[Internal State Reg] ETI	Logic address: 0C86 hex = 3206	Type: WORD (BitString16) Read/write: R Unit: -
Internal State register		

	Bit 0	Bit 1	Bit 2	Bit 3
Function	<i>Write parameter authorization</i>	<i>Parameter consistency check</i>	<i>Starter reset authorization</i>	<i>Motor preheating</i>
Bit at 0	Access to the non-volatile memory stopped.	Not active.	The device: <ul style="list-style-type: none"> is not in operating state "Error" is in operating state "Error" and the error is active. 	Not active.
Bit at 1	Access to the non-volatile memory in progress.	Active.	The device is in operating state "Error" and the error is no longer active (not reset).	Active.

	Bit 4	Bit 5	Bit 6	Bit 7
Function	<i>Motor operating status</i>	<i>Braking</i>	<i>Starter in continuous operation</i>	<i>Thermal overload warning:</i>
Bit at 0	Not active.	Not active.	Transient state.	Threshold for the active motor not reached.
Bit at 1	Active.	Active.	Steady state.	Threshold for the active motor reached.

	Bit 8	Bit 9	Bit 10	Bit 11
Function	<i>Reserved</i>	<i>Starter accelerating</i>	<i>Starter decelerating</i>	<i>Current limit warning</i>
Bit at 0		Not active.	Not active.	Not active.
Bit at 1		Active.	Active.	Active.

	Bit 12	Bit 13	Bit 14	Bit 15
Function	<i>Torque limit warning</i>	<i>Active mode:</i>		<i>Direction</i>
Bit at 0	Not active.	<ul style="list-style-type: none"> Bit 13 = 0 + Bit 14 = 0: Device controlled by terminal Bit 13 = 1 + Bit 14 = 0: Device controlled by the display terminal Bit 13 = 0 + Bit 14 = 1: Device controlled by Embedded Modbus Bit 13 = 1 + Bit 14 = 1: Device controlled by fieldbus card 		Forward operation applied before the ramp.
Bit at 1	Active.			Reverse operation applied before the ramp.

Starting Sequence

What's in This Chapter

Sequence for a Soft starter..... 67
 Sequence for a Soft starter with Mains Contactor Control 70

Description

The command sequence in the state diagram depends on how power is being supplied to the soft starter.

NOTE: This example is given when **[Control Mode]** is set to **[Standard Profile]**.

There are 2 possible scenarios:

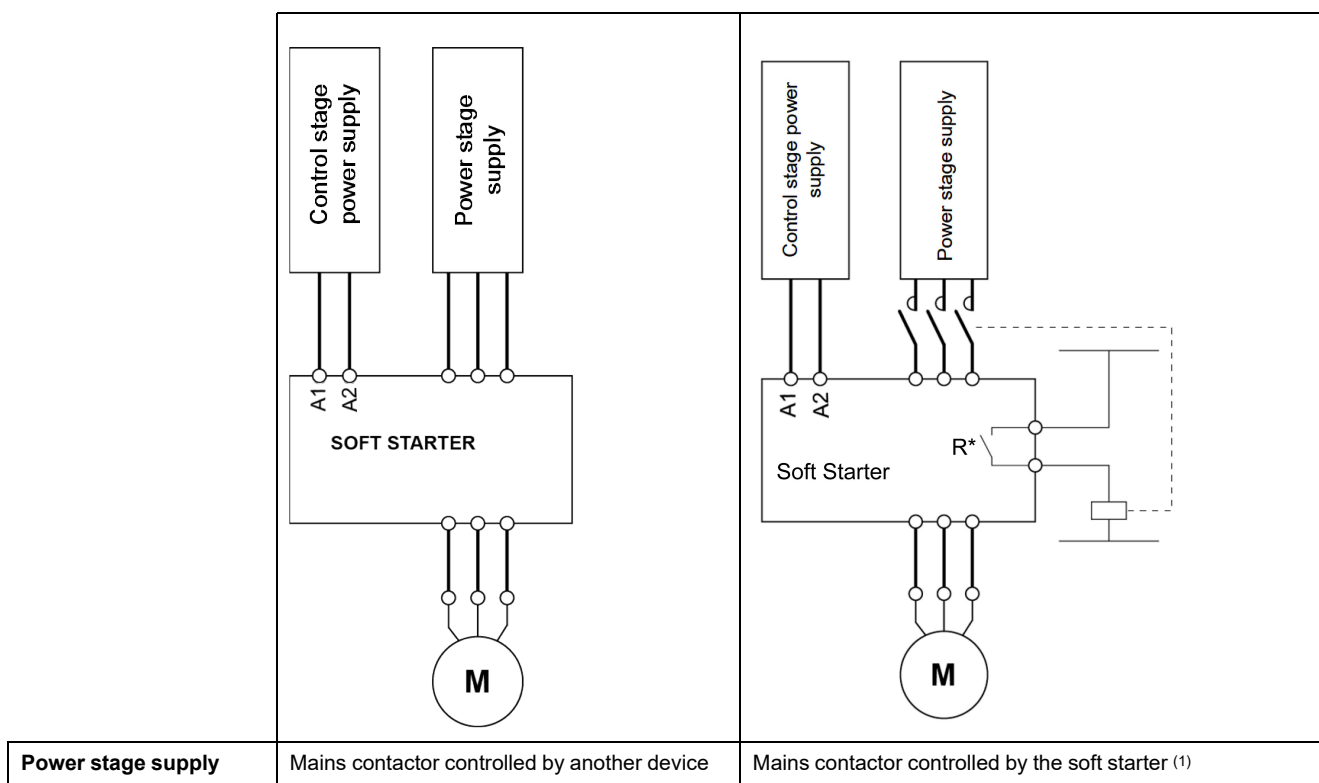

NOTE:

⁽¹⁾ and R*: **[R1 Assignment]** R1, **[R2 Assignment]** R2 or **[R3 Assignment]** R3 assigned to **[Mains Contactor]**.

NOTE: If **[Mains Contactor]** is set to a specific relay (R1, R2 or R3) no other relay can be assigned to this function.

Sequence for a Soft starter

Description

Power is supplied separately to the power and control stages. The following sequence must be applied:

Step 1

- In **[Standard Profile]**, **[Cmd channel 1]** or **[Cmd channel 2]** must be set to and active.
- The power stage supply is not necessarily present.
- Apply the **2 - Shut down** transition command.

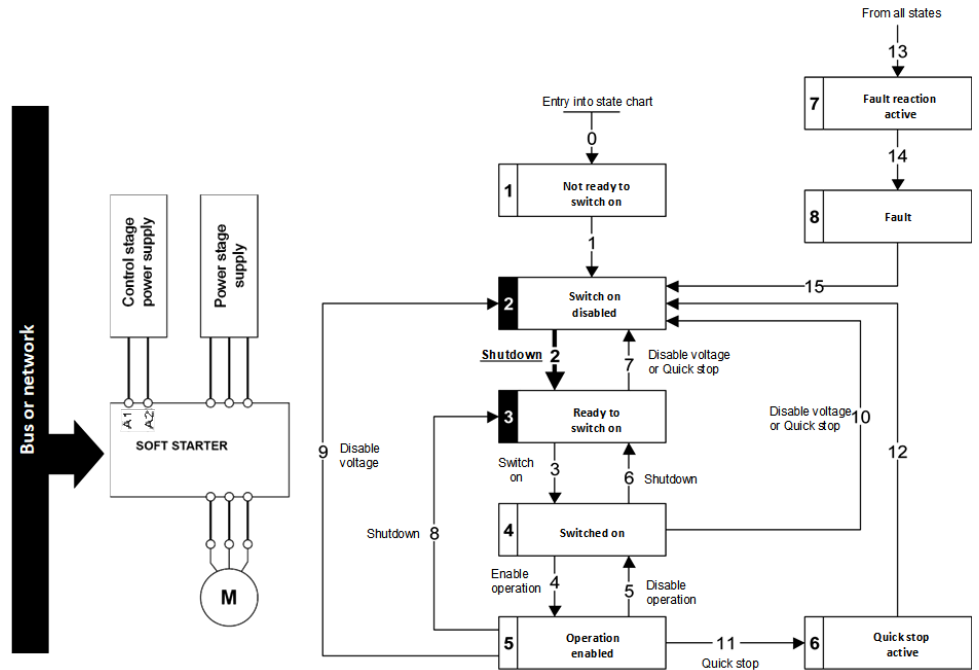

Step 2

- Check that the soft starter is in the operating state 3 - *Ready to switch on*.
- The power stage supply could be present (*Voltage enabled* of the status word).

Power Stage Supply	Terminal Display	Status Word
Absent	NLP	21 hex
Present	RDY	31 hex

- Apply the 3 - *Switch on* transition command

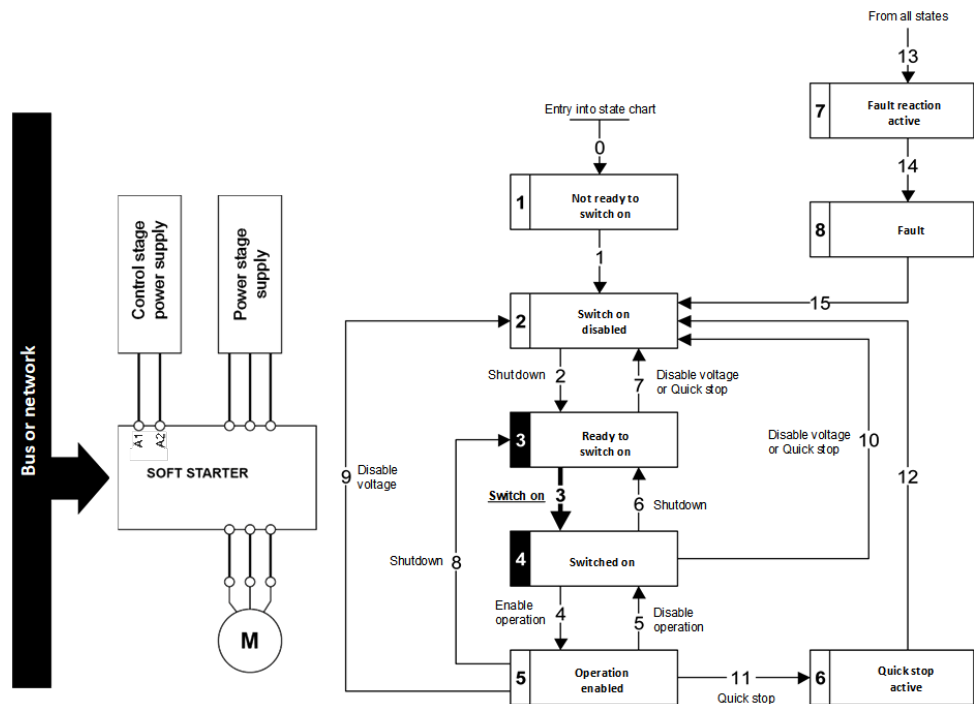

Step 3

- If power supply is present; check that the soft starter is in the operating state 4 - *Switched on*.
- **NOTE:** If power supply is not present, we stay in 3 - *Ready to switch on*.
- Then apply the 4- *Enable operation* transition command.
- The motor starts.

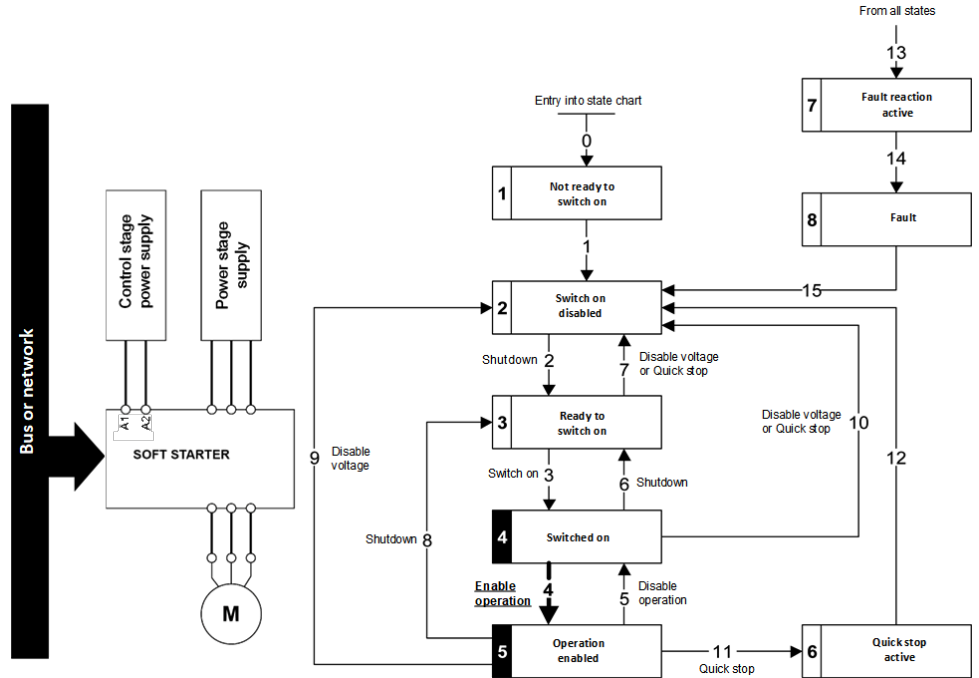

Sequence for a Soft starter with Mains Contactor Control

Description

Power is supplied separately to the power and control stages. If the soft starter controls the mains contactor the following sequence must be applied:

Step 1

- In **[Standard Profile]**, **[Cmd channel 1]** or **[Cmd channel 2]** must be set to and active.
- The power stage supply is not present as the mains contactor is not being controlled.
- Apply the 2 - *Shut down* transition command.

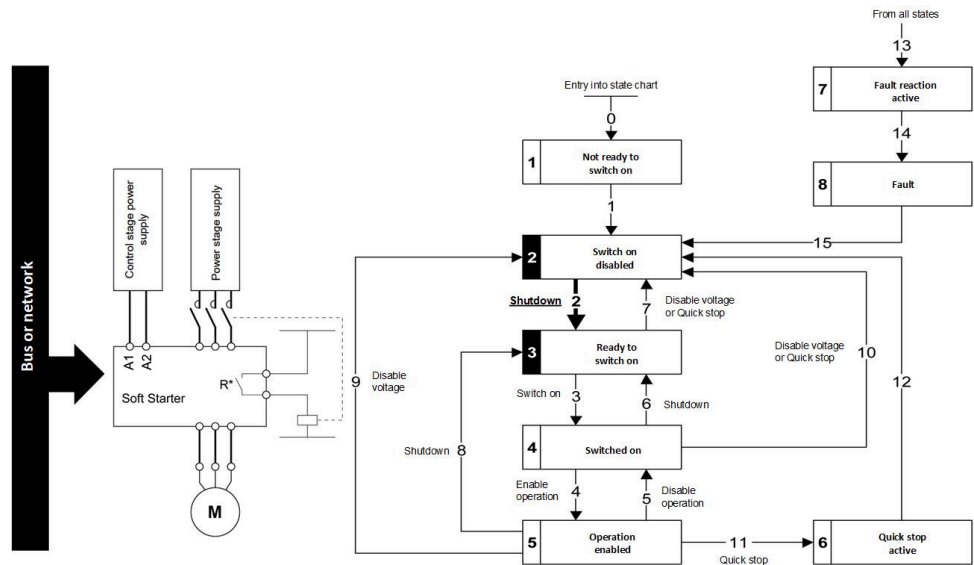

Step 2

- Check that the soft starter is in the operating state 3 - *Ready to switch on*.

Power Stage Supply	Terminal Display	Status Word
Absent	NLP	21 hex

- Apply the 3 - *Switch on* transition command.

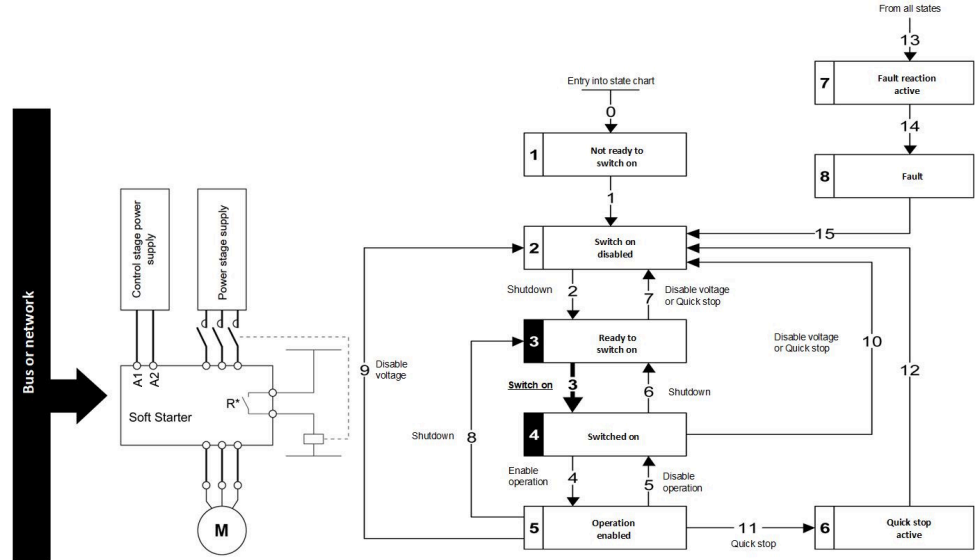

Step 3

- Apply the 4- *Enable operation* transition command which closes the mains contactor and switch on the power stage supply by giving RUN command.

NOTE: If the power stage supply is still not present in the operating state 5 - *Operation enabled* after a time delay [**Mains V. time out**], the soft starter triggers an error [**Input Contactor**].

- The motor starts.

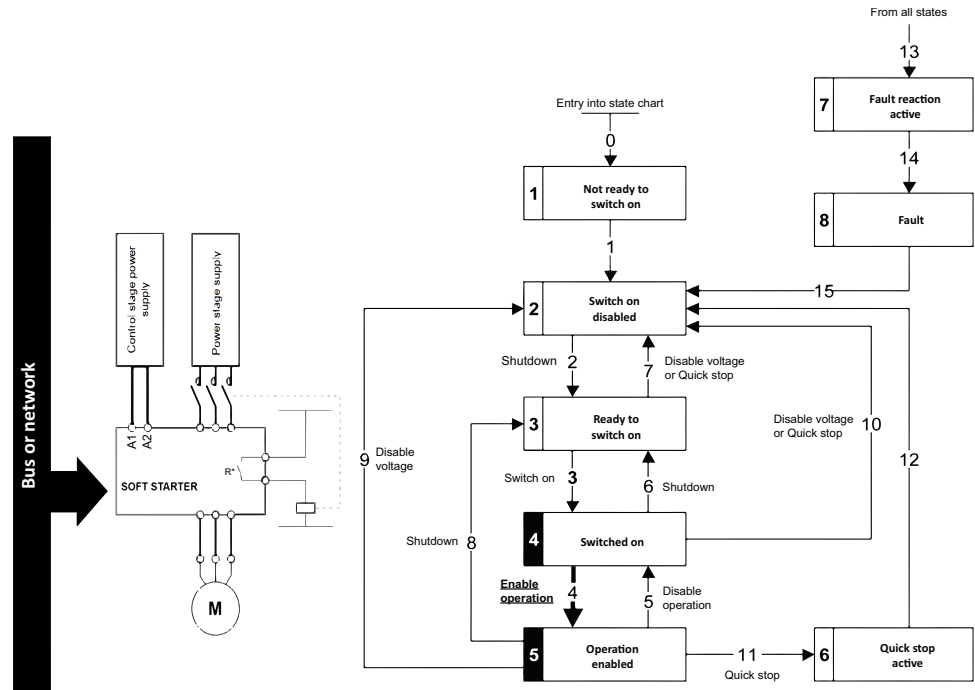

Description Telegram 100, 101, 102, 106, 107

Overview

The telegrams 100,101, 102, 106, 107 are compliant with the native mode (CIA402 native profile).

The following diagram shows the native modes for telegram 100:

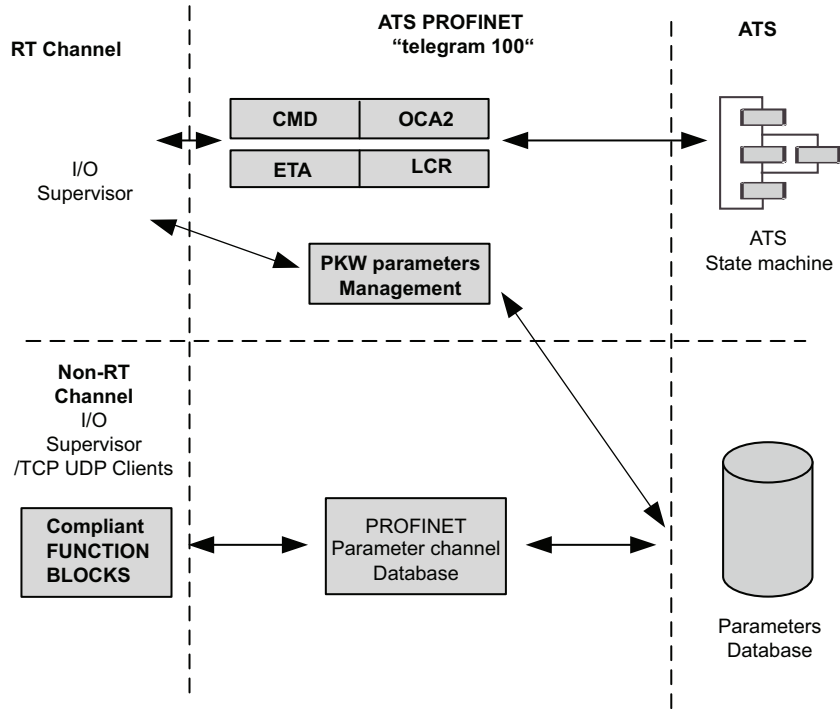

The PKW area of telegram 100, which is used for a simple parameter management, is compliant with the PKW mechanism used with the module.

The following diagram shows the native modes for telegram 101, 106 and 107 (for the telegram 106 and 107, more OMAx and OCAX are available, refer to Periodic Exchanges, page 74):

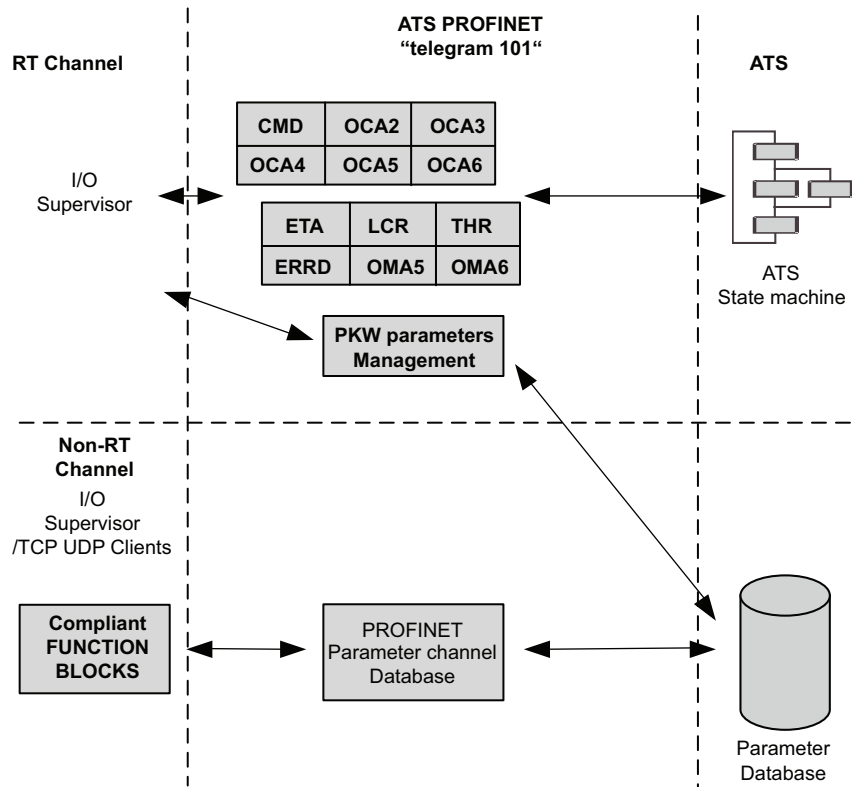

The following diagram shows the native modes for telegram 102:

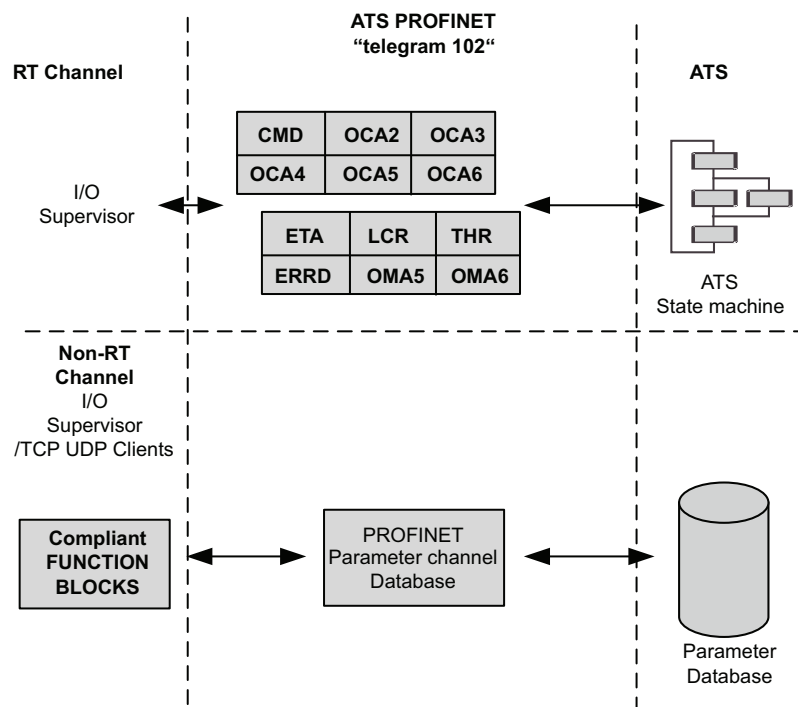

Periodic Exchanges

The following table provides the details of telegram 100, 101, and 102

	Telegram 100		Telegram 101		Telegram 102	
	PLC>Soft Starter	Soft Starter>PLC	PLC>Soft Starter	Soft Starter>PLC	PLC>Soft Starter	Soft Starter>PLC
PKW 1	PKE	PKE	PKE	PKE	-	
PKW 2	R/W	R/W	R/W	R/W		
PKW 3	PWE	PWE	PWE	PWE		
PKW 4	PWE	PWE	PWE	PWE		
Cyclic data 1	OCA1 address of CMD =8501*	OMA1 address of ETA =3201*	OCA1 address of CMD =8501*	OMA1 address of ETA =3201*	OCA1 address of CMD =8501*	OMA1 address of ETA =3201*
Cyclic data 2	OCA2 default =0	OMA2 address of LCR=3204*	OCA2 default =0	OMA2 address of LCR=3204*	OCA2 default =0	OMA2 address of LCR=3204*
Cyclic data 3			OCA3 default =0	OMA3 address of THR = 9630*	OCA3 default =0	OMA3 address of THR =9630*
Cyclic data 4			OCA4 default =0	OMA4 address of ERRD = 8606*	OCA4 default =0	OMA4 address of ERRD =8606*
Cyclic data 5			OCA5 default =0	OMA5 default =0	OCA5 default =0	OMA5 default =0
Cyclic data 6			OCA6 default =0	OMA6 default =0	OCA6 default =0	OMA6 default =0
*:default Modbus address.						

The following table provides the details of telegram 106 and 107

	Telegram 106		Telegram 107	
	PLC>Soft Starter	Soft Starter>PLC	PLC>Soft Starter	Soft Starter>PLC
PKW 1	PKE	PKE	PKE	PKE
PKW 2	R/W	R/W	R/W	R/W
PKW 3	PWE	PWE	PWE	PWE
PKW 4	PWE	PWE	PWE	PWE
Cyclic data 1	OCA1 address of CMD =8501*	OMA1 address of ETA =3201*	OCA1 address of CMD =8501*	OMA1 address of ETA =3201*
Cyclic data 2	OCA2 default =0	OMA2 address of LCR=3204*	OCA2 default =0	OMA2 address of LCR=3204*
Cyclic data 3	OCA3 default =0	OMA3 address of THR = 9630*	OCA3 default =0	OMA3 address of THR = 9630*
Cyclic data 4	OCA4 default =0	OMA4 address of ERRD = 8606*	OCA4 default =0	OMA4 address of ERRD = 8606*
Cyclic data 5	OCA5 default =0	OMA5 default =0	OCA5 default =0	OMA5 default =0
Cyclic data 6	OCA6 default =0	OMA6 default =0	OCA6 default =0	OMA6 default =0
Cyclic data 7	OCA7 default =0	OMA7 default =0	OCA7 default =0	OMA7 default =0
Cyclic data 8	OCA8 default =0	OMA8 default =0	OCA8 default =0	OMA8 default =0
Cyclic data 9			OCA9 default =0	OMA9 default =0
Cyclic data 10			OCAA default =0	OMAA default =0
Cyclic data 11			OCAB default =0	OMAB default =0
Cyclic data 12			OCAC default =0	OMAC default =0
Cyclic data 13			OCAD default =0	OMAD default =0
Cyclic data 14			OCAE default =0	OMAE default =0
Cyclic data 15			OCAF default =0	OMAF default =0
Cyclic data 16			OCAG default =0	OMAG default =0
*:default Modbus address.				

The configuration of the cyclic data is made with the PROFINET IO controller configuration tool. The Modbus address of the parameter linked to each cyclic data must be defined as in the following example with the HW configuration software:

Output cyclic data 1 and Input cyclic data 1 / 2 / 3 / 4 are already preconfigured to **[Cmd Register] CMD** (8501); **[Status Register] ETA** (3201), **[Motor Current] LCR** (3204), **[Motor Therm State] THR** (9630) and **[CiA402 Error Code] ERRD** (8606).

If a null address Modbus is entered, no link between the related cyclic data and the soft starter is established. In any case, the unconfigured cyclic data are not disabled and they take place in the I/O memory image of the controller.

Here, an example with the Telegram 106:

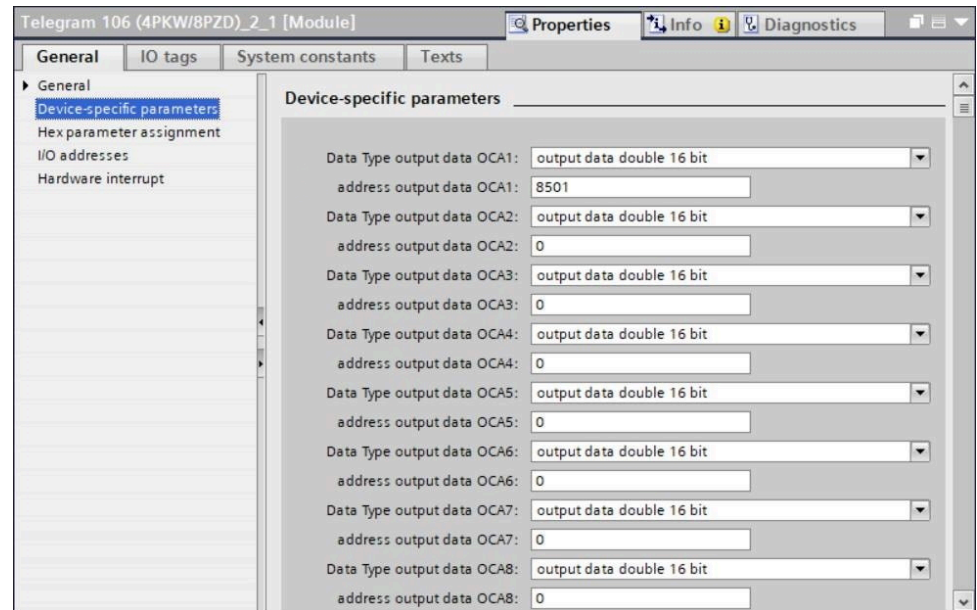

Configuring the soft starter with TIA Portal

GSDML Installation

First download, and install the GSDML file of the soft starter in the hardware configuration tool of the TIA Portal software.

NOTE: SIMATIC STEP7® is supported by TIA Portal.

You can find the GSDML file and its associated picture on www.se.com.

From the menu → **Options** → **Manage general station description**.

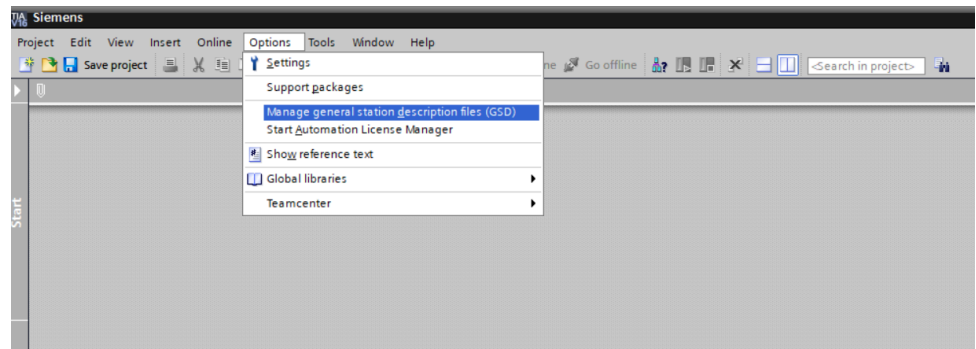

Configuration of a soft starter with the Telegram 100

Description

Configure the PLC and its PROFINET network. Then select and place the soft starter from the library to the bus and add a Module **Telegram 100**:

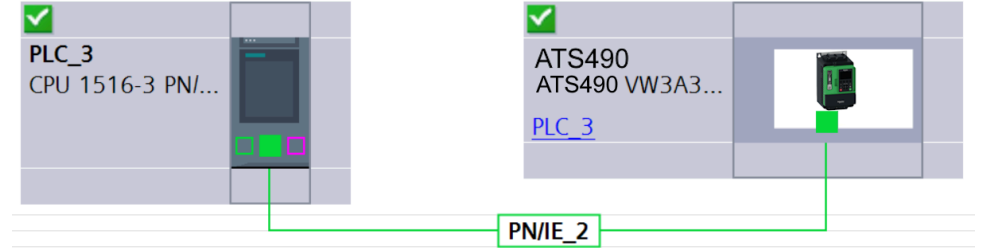

Define the addresses of the cyclic data (PZD) and PKW data in the PLC periphery:

Module	Rack	Slot	I address	Q address	Type	Article no.	Firmware	Comment
ATS490_1	0	0			ATS4xx		Version 1.16	
Telegram 100 (4PKW/2PZD)...	0	1	264...271	266...273	Telegram 100 (4PK...			
Telegram 100 (4PKW/2PZD)...	0	2	272...275	274...277	Telegram 100 (4PK...			

By default, the process data are linked to **[Cmd Register] CMD**; **[Status Register] ETA** and **[Motor Current] LCR**.

The screenshot shows the 'Device-specific parameters' configuration window for the Telegram 100 (4PKW/2PZD)_2_1 module. The parameters are:

- address output data OCA1: 8501
- address output data OCA2: 0
- address input data OMA1: 3201
- address input data OMA2: 3204

After downloading the program to the PLC and commissioning the soft starter, check that the exchanges are working properly by checking the green icon next to the product.

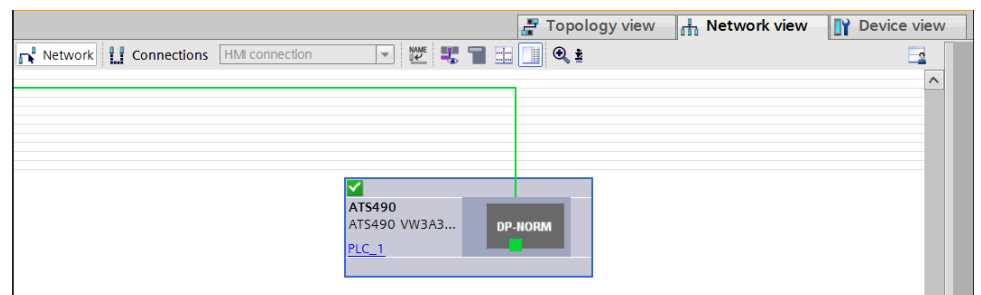

Configuring a soft starter with the Telegram 101, 102, 106, or 107

Configuring the soft starter Communication Scanner

By default, the process data are linked to: **[Cmd Register] CMD**; **[Status Register] ETA**, **[Motor Current] LCR**, **[Motor Therm State] THR** and **[CiA402 Error Code] ERRD**. The other next read or write parameters are not configured.

To add new parameters or modify the default configuration of the communication scanner, open the properties dialog box of the device and configure the OCA/OMA values in the parameter assignment tab.

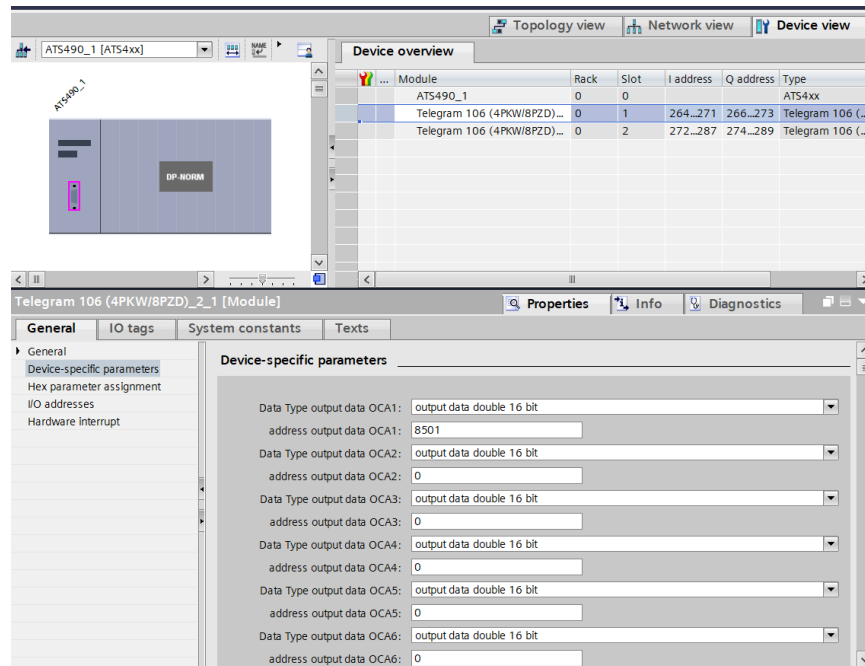

New parameters are added or modified by entering the soft starter Modbus address.

Parameters Management with the Telegram 100, 101, 102, 106, 107

Description

In native modes several accesses to the soft starter parameters are possible:

- The standard acyclic requests from PROFIdrive, for more information see [Soft Starter Parameters Access Channel](#), page 81.
- PKW mechanisms for 16-bit data and 32-bit data.

Parameter Management Through the PKW Area

With telegram 100, 101, 106, 107 you can read or write any soft starter parameter by using this PKW area. (This addressing format is identical to the PKW mechanism).

NOTE: The management of the parameters using PKW area is a mechanism implemented by Schneider Electric

NOTE: Soft starter parameters can be accessed through acyclic requests as defined in the PROFIdrive standard.

The PKW area is made of four input words and four output words.

The table lists the controller-to-soft starter parameters in the input PKW area:

PKW Number	PKE Name	Description
PKW1	PKE	The Modbus address of the parameter is detailed here.
PKW2	R/W	Request code: 0: no request 1: read 2: write (16 bit) 3: write (32 bit)
PKW3	PWE	Parameter is used when PKW2 = 3
PKW4	PWE	Parameter value in case of write request

The table lists the soft starter-to-controller parameters in the output PKW area:

PKW Number	PKE Name	Description
PKW1	PKE	Copy of the input PKE
PKW2	R/W	Response code: 0: no request 1: read done (16 bit) 2: write done (16 bit) 3: request in progress 4: read done (32 bit) 5: write done (32 bit) 7: read or write error
PKW3	PWE	Parameter is used when PKW2 = 4 or 5
PKW4	PWE	If the request is successful, the parameter value is copied here.

Identification and Maintenance Data

Overview

Identification & maintenance (I&M) is established through PNO.

Supports the user during various scenarios of the device life cycle, such as:

- Configuration
- Commissioning
- Repair and update
- Operation and visualization

The access to the identification & maintenance data can be achieved using the PROFINET mechanisms (IEC 61158-6).

Soft Starter Parameters Access Channel

What's in This Chapter

Acyclic soft starter parameters access	82
Device profile request structure	83
Soft Starter Parameters Access.....	84

Acyclic soft starter parameters access

The soft starter parameters are organized as defined by PNU numbering and addressing modes. However, this addressing mode keeps the native structure of the device (based on Modbus addressing).

In the case of this soft starter, parameters which are gathered in a single PNU entry point: PNU1000 and Modbus address as subindex.

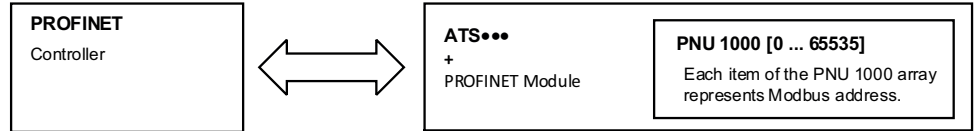

Device profile request structure

The table describes the device profile header as used for the device parameters access:

DU	Byte Nr	Request
Function code	0	-
Slot_num	1	0: global parameters
Index	2	Reserved for the device profile: • 47: Base Mode Parameter Access-Global
Length	3	Length of the parameter channel frame
Data	4...5	Parameter channel frame: check

Device Parameter Structure

A parameter is defined with its PNU number from 1...65535.

Each parameter consists of 3 main areas:

- **PWE**: the value
- **PBE**: describes the parameter attributes
- Text area

The access to the 3 different areas of a parameter is specified by the **attribute field** of the parameter request.

The parameters and their sub parts are identified as follows:

PNU number + attribute	10 hex	PWE	+ Sub index
	20 hex	PBE	+ Sub index
	30 hex	Text	+ Sub index

Detail of the PBE Attribute

The diagram describes the PBE attribute:

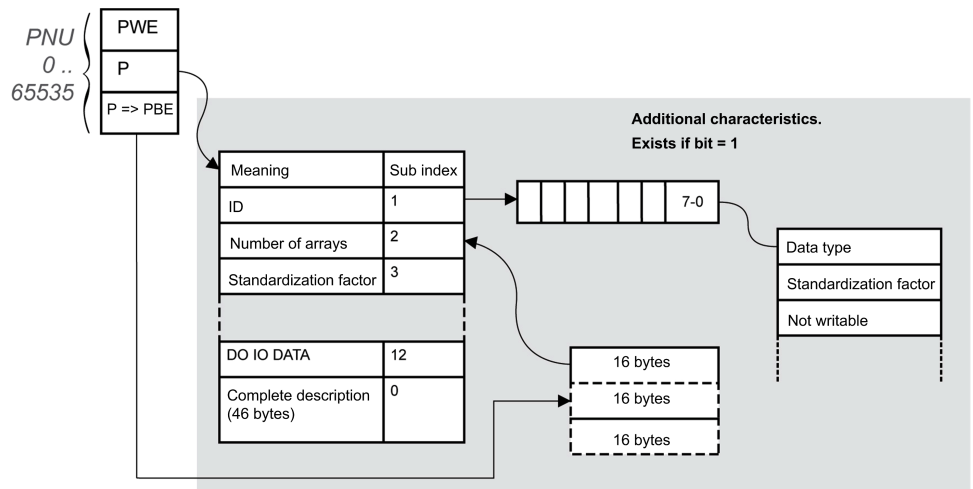

Soft Starter Parameters Access

Each soft starter parameter can be represented according to the PNU standard structure.

The table provides the possible values of a parameter according to the PNU properties:

Parameter Property	Soft Starter Implementation	Example
PNU number	1000	–
Sub index	Modbus address	[Status Register] ETA (3201)
PWE	Value of the parameter 0...65535	–
PBE	Describes an array of 65535 words	Constant
Text	–	Soft Starter parameter

Parameters Request

These requests are able to manage one or more parameters or several attributes of one parameter. In order to access to a specific attribute of a parameter, the request header contains: the PNU, the sub index, and an attribute. This attribute defines whether the request mentions the value, the description area, or the text area.

NOTE: Change device parameter request is not possible.

Parameter Reading

Request

	Byte n+1	Byte n
Request data	Request reference = 01	Request ID = 01
	Axis = 01 hex	Number of parameters = 01
	Attribute = 10 hex *	Number of elements = 01
	PNU number = 3E8 hex	
	Device parameter address = C81 hex (3201) ETA Modbus address	
*refers to field value (PWE), 20 hex refers to the description field (PBE) and 30 hex to the text field.		

Response

	Byte n+1	Byte n
Response header	Request reference = 01	Request ID = 01
	Axis = 01 hex	Number of parameters = 01
Response data	Format = 42 hex *	Number of elements = 01
	PNU value = xxxx hex (value of ETA)	
*format 42 hex specifies that the returned value is a WORD.		

NOTE: Format is defined by the following returned value: byte 41 hex, word: 42 hex, standard integer: 03 hex, double word: 43 hex.

Request for Negative Response

The table lists the items of a negative response:

	Byte n+1	Byte n
Request header	Request reference = 01	Request ID = 82*
	Axis = 01 hex	Number of parameters = 01
Parameter number	Format = error 44 hex	Number of values
Value	0x00: Impermissible PNU 0x01: Cannot change value 0x02: Low or high limit exceeded + sub index 0x03: Sub index detected error + sub index 0x04: No array 0x05: Incorrect data type 0x06: Setting not permitted + sub index 0x07: Cannot change description + sub index 0x09: No description 0x0B: No operation priority 0x0F: No text array available 0x11: Cannot execute the request. Reason not specified 0x14: Value impermissible	0x15: Response too long 0x16: Parameter address impermissible 0x17: Illegal format 0x18: Number of values inconsistent 0x19: Axis/DO nonexistent 0x20: Cannot change text 0x65: Invalid request reference 0x66: Invalid request ID 0x67: Invalid axis number / DO-ID 0x68: Invalid number of parameters 0x69: Invalid attribute 0x6B: Request too short
*for all negative responses the ID equals to response code or 80 hex.		

With the sub index in addition to the detected error value, the total length of the answer is 10 bytes.

Monitoring of Communication Channel

Communication channels are monitored if they are involved in the control word **[Cmd Register]** from the active command channel.

As soon as this register has been written once to a communication channel, it activates monitoring for that channel.

If an interruption of communication is triggered in accordance with the protocol criteria by a monitored port or fieldbus module, the soft starter react according to **[Fieldbus Interrupt Resp]** configuration, refer to [Configuring Communication Error Response](#), page 92 for more information.

If an interruption of communication is triggered on a channel that is not being monitored, the soft starter does not trigger a communication error/warning.

Diagnostics and Troubleshooting

What's in This Part

Fieldbus Status LEDs	88
Connection problem with the fieldbus module	91
Configuring Communication Error Response	92
Communication troubleshooting	93
Fieldbus Response Test.....	94
Control-Signal Diagnostics.....	96
Communication error codes	97

Fieldbus Status LEDs

LED Description

The following figures describes the LEDs status on control block:

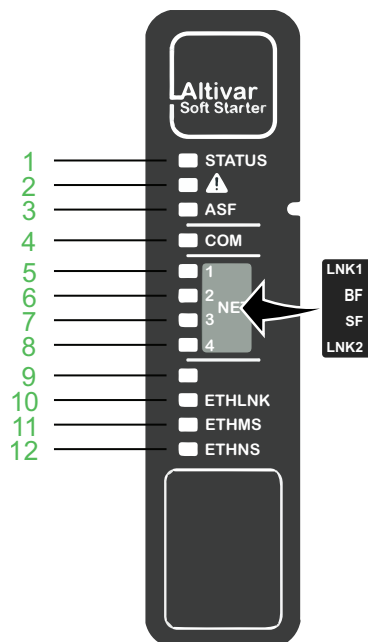

Item	LED		Description
1	STATUS	OFF	Indicates that the soft starter is not ready to start
		Green flashing	Indicates that the soft starter is not running, ready to start
		Green blinking	Indicates that the soft starter is in transitory status (acceleration, deceleration, and so on)
		Green on	Indicates that the soft starter is running
		Yellow on	Indicates that the soft starter localization is in progress
2	Warning/Error	Red flashing	Indicates that the soft starter has detected a warning
		Red on	Indicates that the soft starter has detected an error
3	ASF	OFF	Indicates Safety Function STO is not active.
		Yellow on	Indicates Safety Function STO is triggered.
4	COM	Yellow flashing	Indicates Modbus serial activity on port Modbus VP12S port.
5	LNK1	Green/Yellow	Port A activity
6	BF	Green/Red	Bus Fault
7	SF	Green/Red	System Fault
8	LNK2	Green/Yellow	Port B activity
9	Reserved		
10	ETHLNK	Green/Yellow	Indicates port activity
11	ETHMS	Green/Red	Indicates module status.
12	ETHNS	Green/Red	Indicates network status

BF Status

This LED indicates the module status (loose connections, defective cables, incorrect bus addresses, missing termination):

Color & Status	Description
OFF	The device is powered off
Red ON	The device has detected an ILF error
Green ON	The device is ready and operational
Red flickering	The device has detected a communication interruption / wrong configuration or a PROFINET controller at <code>Stop</code> state.
Green flickering	In combination with other LEDs: DCP manual identification phase / DCP flash mode
Green/Red blinking	Power up testing
Red single flash	No connection to the PROFINET controller

SF Status

This LED indicates the SF error status (defective module, power error, programming errors):

Color & Status	Description
OFF	The device does not have an IP address or is powered off
RED ON	Error detected on the module
Green ON	At least a port is connected and has a valid IP address.
Green flickering	In combination with other LEDs: DCP manual identification phase / DCP flash mode or as long as the iPar-Client did not accomplish transfer (backup or restore) its parameters
Green/Red blinking	Power-up testing
Green flashing 3 times	All ports are unplugged, but the module has an IP address
Green flashing 4 times	Error detected: duplicate IP address
Green flashing 5 times	The module is performing a DHCP sequence

LNK1 and LNK2

These LEDs indicate the status of the Ethernet adapter ports:

Color & status	Description
OFF	No link
Blinking Green/ Yellow	Power on testing
Green ON	Link established at 100 Mbit/s
Blinking Green	Network activity at 100 Mbit/s
Yellow ON	Link established at 10 Mbit/s
Blinking Yellow	Network activity at 10 Mbit/s

LED Behavior

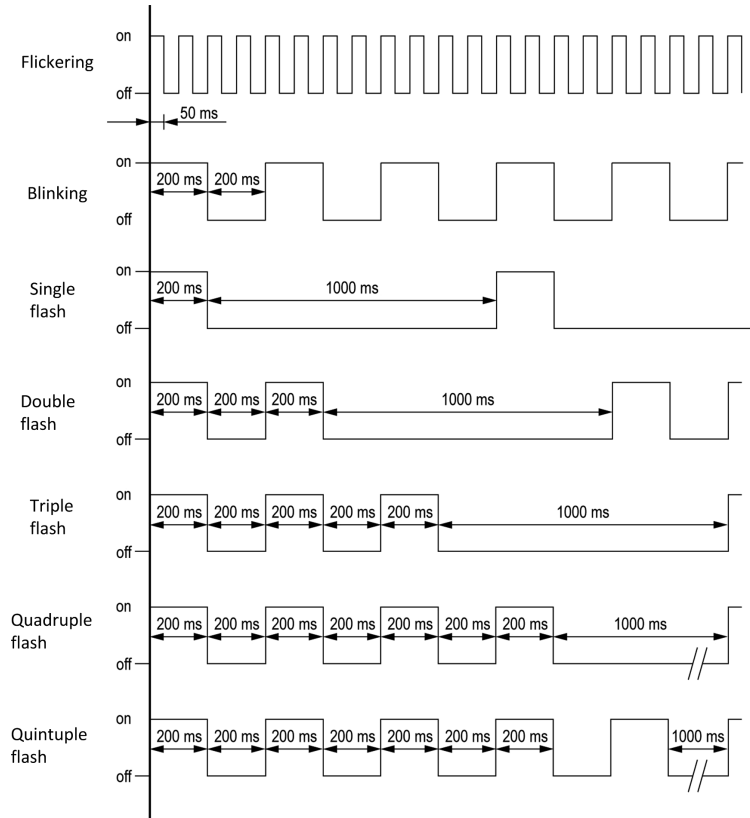

Connection problem with the fieldbus module

Description

If the product cannot be addressed via the fieldbus, first check the connections. The product manuals contains the technical data of the device and information on fieldbus and device installation.

Verify the following:

- Power connections to the device.
- Fieldbus cable and fieldbus wiring.
- Fieldbus connection to the device.

Configuring Communication Error Response

⚠ WARNING
LOSS OF CONTROL
Perform a comprehensive commissioning test to verify that communication monitoring properly detects communication interruptions.
Failure to follow these instructions can result in death, serious injury, or equipment damage.

The communication timeout is set via the PLC.

The response of the soft starter in the event of a communication interruption can be configured through **[Fieldbus Interrupt Resp]** *CLL* in the **[Communication]** menu of the graphic display terminal.

Configuration can be performed using the display terminal from:

[Communication] ➔

The values of the **[Fieldbus Interrupt Resp]** *CLL* parameter which:

Value	Meaning
triggers a [Fieldbus Com Interrupt] <i>CNF</i> error are:	
[Freewheel Stop] <i>YES</i>	Motor triggers in error and is stopped in freewheel. Factory setting
[Deceleration] <i>DEC</i>	Motor is stopped in deceleration and triggers in error at the end of stop.
[Braking] <i>BRK</i>	Motor is stopped in dynamic braking and triggers in error at the end of stop.
does not trigger an error are:	
[Ignore] <i>NO</i>	Detected error ignored (in this case, the warning [Modbus Com Warn] <i>SLLA</i> [CANopen Com Warn] <i>COLA</i> [Fieldbus Com Warn] <i>CLLA</i> should be assigned to a warning group in [Warning groups config] to be visible when triggered. is activated).
[Configured Stop] <i>STT</i>	Motor is stopped according to [Type of stop] <i>STT</i> parameter.

Communication troubleshooting

Checking Connections

If the product cannot be addressed using the fieldbus, verify that:

- The connector is plugged in correctly.
- The soft starter and the PLC are supplied.
- The wires are correctly connected to the port (if possible).
- The wiring of the all devices on the network is consistent.

Behavior when an communication error occurs

Send a word with **[Cmd Register]** to validate the **[Cmd channel 1]** or the **[Cmd channel 2]** to activate this channel.

If a communication interruption appears:

1. After the end of the delay of timeout, the motor is stopped.
2. An error **[Fieldbus Com Interrupt] CNF** is triggered, and depending of **[Auto Fault Reset]**, **[R1 Assignment]** is deactivated (if set to **[Operating State Fault]** following the value set on **[Fieldbus Interrupt Resp]**).

Fieldbus Response Test

Description

If the connections are correct, check the settings for the fieldbus addresses. After correct configuration of the transmission data, test the fieldbus mode.

In addition to the controller that knows the device via the data in the GSDML file and its address, a bus monitor should be installed. As a passive device, it can display messages.

- Switch off or on the supply voltage of the soft starter system.
- Observe the network messages shortly after switching on the soft starter. A bus monitor can be used to record the elapsed time between telegrams and the relevant information in the telegram.

Possible Errors: Addressing, Parameterization, Configuration

If it is impossible to connect to a device, check the following:

- Addressing: The address of the network device must be a valid IP address. Each network device must have a unique address.
- Parameterization: The parameterized ident number and the user parameters must match the values stored in the GSDML file.

Communication Interruption

Description

The soft starter triggers an error **[Internal Link Error]** *ILF* when the following events occur:

- Hardware error is detected on the PROFINET module
- Communication interruption between the PROFINET module and the soft starter

The response of the soft starter in the event of an **[Internal Link Error]** *ILF* error cannot be configured, and the soft starter stops in freewheel. This detected error requires a power reset.

The diagnostic parameter can be used to obtain more detailed information about the origin of the **[Internal Link Error]** *ILF* (**[InternCom Error1]** *ILF1* if the detected error has occurred on fieldbus module).

The **[InternCom Error1]** *ILF1* parameter can be accessed on the graphic display terminal in **[Communication]** → **[Profinet diag]**

Value	Description of the values of the [Internal Link Error] <i>ILF</i> parameter
0	No error detected
1	Internal communication interruption with the soft starter
2	Hardware error detected
3	Error found in the EEPROM checksum
4	EEPROM
5	Flash memory
6	RAM memory
7	NVRAM memory
101	Unknown module
102	Communication interruption on the soft starter internal bus
103	Time out on the soft starter internal bus (500 ms)

Control-Signal Diagnostics

On the display terminal, the **[Communication]**– menu can be used to display control-signal diagnostic information between the soft starter and the controller:

- Active command channel **[Command Channel]**.
- Value of the control word **[Cmd Register]** from the active command channel **[Command Channel]**.
- Value of the operating state word **[Status Register]**.
- Specific data for all available fieldbuses are in dedicated submenus.

Communication error codes



What's in This Chapter

[Incorrect Config] CFF	98
[Invalid Configuration] CFI	98
[Fieldbus Com Interrupt] CNF	98
[External Error] EPF1	99
[Fieldbus Error] EPF2	99
[Internal Link Error] ILF	99
[Internal Error 6] INF6	100
Diagnostic (PROFINET Service).....	101

In this chapter, a list of some of the errors that can be triggered by the communication-related soft starter can be found, for a full description please refer to the user manual.



[Incorrect Config] CFF

Incorrect configuration

 Probable Cause	<ul style="list-style-type: none"> Option module has been changed for another fieldbus or removed. Control block replaced by a control block configured on a soft starter with a different rating. The current configuration is inconsistent.
 Remedy	<ul style="list-style-type: none"> Verify that the option module or the product are not damaged. In the event of the control block being changed deliberately, see the remarks below. Press the OK key to validate the message displayed on the display terminal. This action will set a return to factory settings. Or retrieve the backup configuration if it is valid.
 Clearing the Error Code	<p>This detected error is cleared as soon as its cause has been removed.</p>



[Invalid Configuration] CFI

Invalid configuration

 Probable Cause	<p>Inconsistent, invalid, unauthorized or out-of-bound value written to a parameter via a fieldbus or communication link. The written value is rejected, the previous one is kept and this error is triggered.</p>
 Remedy	<ul style="list-style-type: none"> Writing a correct value on any parameters via communication or fieldbus link. Writing a correct value on any parameters via any HMI (display terminal, SoMove...). Reset to factory settings, new configuration transfer or configuration restoration.
 Clearing the Error Code	<p>This detected error is cleared as soon as its cause has been removed.</p>



[Fieldbus Com Interrupt] CNF

Fieldbus communication interruption

 Probable Cause	<p>Communication interruption on fieldbus module.</p> <p>This error is triggered when the communication between the fieldbus module and the master (PLC) is interrupted.</p>
 Remedy	<ul style="list-style-type: none"> Verify the environment (electromagnetic compatibility). Verify the wiring. Verify the timeout. Replace the option module. Contact your local Schneider Electric representative.
 Clearing the Error Code	<p>This detected error can be cleared with the [Auto Fault Reset] or manually with the [Fault Reset Assign] parameter after its cause has been removed.</p>



[External Error] EPF1

External detected error

 Probable Cause	<ul style="list-style-type: none"> • Error raised based on [Ext Error assign] configuration via [DI•] or [CD••]. • Duplicate or invalid IP address.
 Remedy	Remove the cause of the external error.
 Clearing the Error Code	This detected error can be cleared manually with the [Fault Reset Assign] parameter after its cause has been removed.



[Fieldbus Error] EPF2

External error detected by Fieldbus

 Probable Cause	Communication interruption with fieldbus module.
 Remedy	<ul style="list-style-type: none"> • Verify the communication bus is correctly wired. • Verify the fieldbus module is correctly plugged into the soft starter. • Refer to the appropriate fieldbus manual.
 Clearing the Error Code	This detected error can be cleared manually with the [Fault Reset Assign] parameter after its cause has been removed.



[Internal Link Error] ILF

Internal communication interruption with option module

 Probable Cause	Communication interruption between option module and the soft starter.
 Remedy	<ul style="list-style-type: none"> • Verify the environment (electromagnetic compatibility). • Verify that the fieldbus module is well inserted in the soft starter. • Replace the fieldbus module with an identical fieldbus module. • Contact your local Schneider Electric representative. <p>NOTE: it is possible to check the status of ILF through the communication with his register (ADL: 7134).</p>
 Clearing the Error Code	This detected error requires a power reset of the device after its cause has been removed.

[Internal Error 6] INF6

Internal error 6 (Option)

 Probable Cause	<p>The compatibility of the option module is monitored internally.</p> <p>If an unknown module is installed, the INF6 error is triggered.</p> <ul style="list-style-type: none"> • The option module is not recognized by the device nor compatible with the device. • An old ethernet embedded version is used.
 Remedy	<ul style="list-style-type: none"> • To identify the error code, convert from decimal (ex: 4111) to hexadecimal (ex: 100F) the code displayed on the display terminal in the parameter [Error Info (INF6)] INF6, read the last two characters on the right (ex: 0F) and refer to the following list: <ul style="list-style-type: none"> ◦ Value = 0x●●00: No error detected. ◦ Value = 0x●●01: No response of the fieldbus module. Unplug and plug back the fieldbus module. ◦ Value = 0x●●09, 0x●●0B, 0x●●11: Incompatible fieldbus module. For the list of compatible fieldbus modules, refer to the catalog and to the fieldbus manuals. ◦ Value = 0x●●0F: Option module software version not compatible. Update the fieldbus module firmware, refer to . • Verify the catalog number and compatibility of the option module. • If the displayed code is not listed above, contact your local Schneider Electric representative.
 Clearing the Error Code	<p>This detected error requires a power reset of the device after its cause has been removed.</p>

Diagnostic (PROFINET Service)

Diagnostic

PROFINET diagnostic is associated with specific data which can be helpful during maintenance:

- The error code, if a detected error is present,
- The value of ETA operating state word,
- The value of **[Motor Current]** LCR
- The value of **[Motor Therm State]** THR

This data report and gives an indication on the soft starter status when the diagnostic event was triggered

Byte	Description	
1	Ext_Diag_Data	External diagnostic data length = 8
2		IF ETA.bit 3 = 1: ADL LFT LSB Otherwise: 0
3		ADL ETA LSB
4		ADL ETA MSB
5		ADL LCR LSB
6		ADL LCR MSB
7		ADL THR LSB
8		ADL THR MSB

Enabling Diagnostics

By default, alarm diagnostics function is enabled. It can be modified during the configuration phase as shown below:

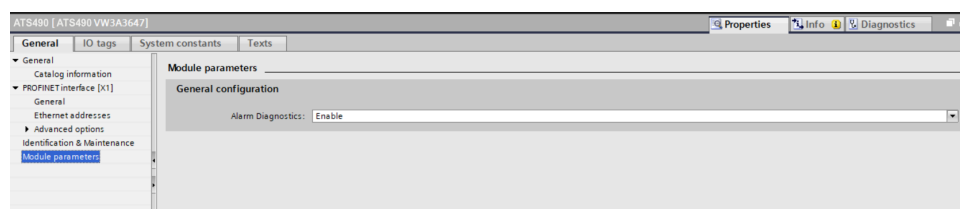

Glossary

A

AC:

Alternating Current

Adjustment parameter: A parameter always accessible as **[Access Level]**.

C

Configuration Parameter: A parameter affects by the operating states of the machine as **[Motor Nom Current]**.

D

DC:

Direct Current

dec.:

Decimal

E

Error :

Discrepancy between a detected (computed, measured, or signaled) value or condition and the specified or theoretically correct value or condition.

F

Factory setting:

Machine status in factory settings when the product was shipped.

Fault Reset:

A function used to restore the soft starter to an operational state after a detected error is cleared by removing the cause of the error so that the error is no longer active.

Fault:

Fault is an operating state. If the monitoring functions detect an error, a transition to this operating state is triggered, depending on the error class. A "Fault reset" is required to exit this operating state after the cause of the detected error has been removed.

H

hex:

Hexadecimal

W

Warning:

If the term is used outside the context of safety instructions, a warning alerts to a potential error that was detected by a monitoring function. A warning does not cause a transition of the operating state.

Schneider Electric
35 rue Joseph Monier
92500 Rueil Malmaison
France

+ 33 (0) 1 41 29 70 00

www.se.com

As standards, specifications, and design change from time to time, please ask for confirmation of the information given in this publication.

© 2025 – 2025 Schneider Electric. All rights reserved.

PKR63424.01 — 03/2025