

Altivar Process

ATV680 Low Harmonic Drive Systems

Handbook

03/2025

NHA37113.03



Legal Information

The information provided in this document contains general descriptions, technical characteristics and/or recommendations related to products/solutions.

This document is not intended as a substitute for a detailed study or operational and site-specific development or schematic plan. It is not to be used for determining suitability or reliability of the products/solutions for specific user applications. It is the duty of any such user to perform or have any professional expert of its choice (integrator, specifier or the like) perform the appropriate and comprehensive risk analysis, evaluation and testing of the products/solutions with respect to the relevant specific application or use thereof.

The Schneider Electric brand and any trademarks of Schneider Electric SE and its subsidiaries referred to in this document are the property of Schneider Electric SE or its subsidiaries. All other brands may be trademarks of their respective owner.

This document and its content are protected under applicable copyright laws and provided for informative use only. No part of this document may be reproduced or transmitted in any form or by any means (electronic, mechanical, photocopying, recording, or otherwise), for any purpose, without the prior written permission of Schneider Electric.

Schneider Electric does not grant any right or license for commercial use of the document or its content, except for a non-exclusive and personal license to consult it on an "as is" basis.

Schneider Electric reserves the right to make changes or updates with respect to or in the content of this document or the format thereof, at any time without notice.

To the extent permitted by applicable law, no responsibility or liability is assumed by Schneider Electric and its subsidiaries for any errors or omissions in the informational content of this document, as well as any non-intended use or misuse of the content thereof.

Altivar Process

ATV680 Low Harmonic Drive Systems



The customized solution for your drive

"Ready-to-use" Low Harmonic Drive Systems:

- + New Low Harmonic system concept
- + Developed on highest quality level
- + Manufactured according to your needs
- + Tested at full-load operating conditions
- + Pre-set appropriate to the design



Newest 3-level architecture

- + Total current distortion factor THD(i) < 5 %
- + Improved life-time of the motor due to reduced voltage load
- + Less losses compared to the classic AFE architecture
- + Compact dimensions due to optimized filter components

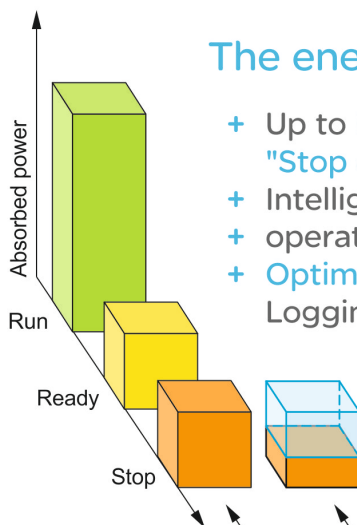
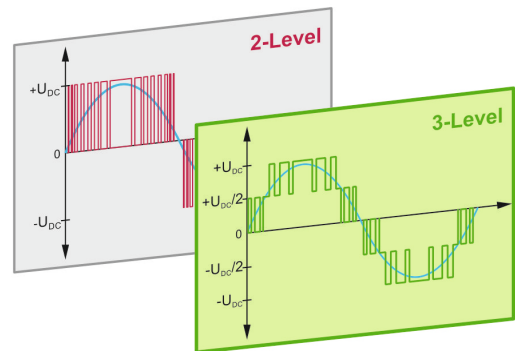

The energy-saving drive solution

- + Up to 60% energy saving at standby due to the innovative "Stop & Go" operation without additional costs
 - + Intelligent control of the internal fans depending on the operation
 - + Optimal energy efficiency over the whole life cycle
- Logging and graphical presentation of the absorbed power



Reduced consumption by Stop & Go function
Conventional consumption



Perfect monitoring of your process

- + Integrated pump curves for process optimization
- + Monitoring of the pump efficiency
- + Notification of critical operating points without additional sensors
- + Process integration with pressure-, flow- and level-control including compensation of flow losses

Simple embedding into PLC environments

- + Easy integration thanks to standardized FDT/DTM and ODVA technology
- + Support by predefined libraries
- + Easy access via PC, tablet or smartphone
- + Secure connection via "Cyber-secured Ethernet"

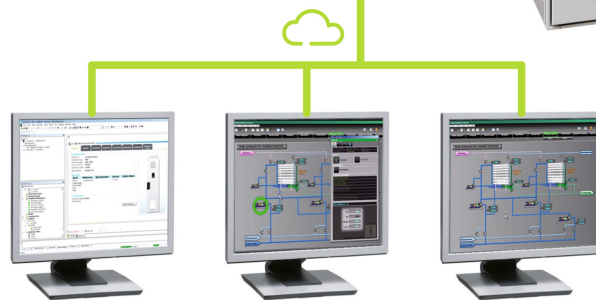
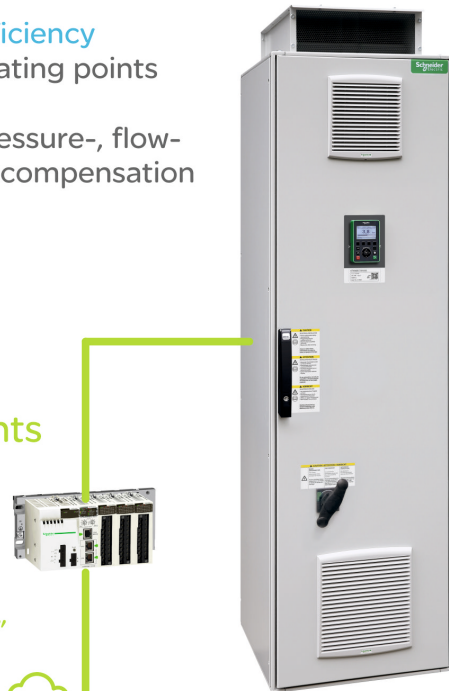

Sophisticated service concept with QR code

- + Modular design allows easy logistics of spare parts
- + Optimized costs of maintenance due to dynamic maintenance schedule with integrated monitoring of the individual components
- + Simple exchange of power modules and fans
- + Quick assistance with dynamic QR codes and Customer Care App

Table of Contents

About the document	7
Validity Note	8
Document Scope	9
Safety Information	10
Related Documents	16
Environmental Data Program	17
Terminology	18
Contact us	19
Drive Systems	20
Overview	21
ATV680 - Low Harmonic Drive Systems	22
Expandability	26
General Specification	29
Quality	30
Mains Conditions	35
Preliminary Instructions	39
ATV680●●●●4X1	45
ATV680 Frequency Inverter for 400 V Mains	46
General Technical Data	47
Protection Degree	49
Cooling concept	50
Maximum Ambient Temperature	51
Specification	52
Circuit Diagram	81
Mains Connection	82
Motor Connection	86
Predefined Customizations	94
Wiring of the Control Terminals	96
Design/Position of the Individual Terminals	97
Control Block	100
Option "Logic and Analog I/O Card"	112
Option "Relay Output Card"	116
Option Terminals	118
Customizations	121
Enclosure Options	122
Control Options	127
I/O Expansion Cards	129
Communication Cards	131
Functional Safety	134
Display Options	136
Motor Options	138
Mains Supply	142
EcoStruxure Asset Advisor	145
Documentation / Packaging	147

About the document

What's in This Part

Validity Note.....	8
Document Scope	9
Safety Information	10
Related Documents.....	16
Environmental Data Program	17
Terminology.....	18
Contact us	19

Validity Note

Original instructions and information given in the present document have been written in English (before optional translation).

This documentation is valid for the Altivar Process Drive Systems.

The characteristics of the products described in this document are intended to match the characteristics that are available on www.se.com. As part of our corporate strategy for constant improvement, we may revise the content over time to enhance clarity and accuracy. If you see a difference between the characteristics in this document and the characteristics on www.se.com, consider www.se.com to contain the latest information.

Document Scope

This document gives you an overview of the available Altivar Process Drive Systems. Additionally, you can choose from the detailed options to customize the Altivar Process Drive System to meet your system's specific needs.

Safety Information

What's in This Chapter

Qualification of Personnel 11
 Intended Use 11
 Product Related Information 12

NOTICE

Read these instructions carefully, and look at the equipment to become familiar with the device before trying to install, operate, service, or maintain it. The following special messages may appear throughout this documentation or on the equipment to warn of potential hazards or to call attention to information that clarifies or simplifies a procedure.



The addition of this symbol to a “Danger” or “Warning” safety label indicates that an electrical hazard exists which will result in personal injury if the instructions are not followed.



This is the safety alert symbol. It is used to alert you to potential personal injury hazards. Obey all safety messages that follow this symbol to avoid possible injury or death.

⚠ DANGER
DANGER indicates a hazardous situation which, if not avoided, will result in death or serious injury.

⚠ WARNING
WARNING indicates a hazardous situation which, if not avoided, could result in death or serious injury.

⚠ CAUTION
CAUTION indicates a hazardous situation which, if not avoided, could result in minor or moderate injury.

NOTICE
NOTICE is used to address practices not related to physical injury.

PLEASE NOTE

Electrical equipment should be installed, operated, serviced, and maintained only by qualified personnel. No responsibility is assumed by Schneider Electric for any consequences arising out of the use of this material.

A qualified person is one who has skills and knowledge related to the construction and operation of electrical equipment and its installation, and has received safety training to recognize and avoid the hazards involved.

Qualification of Personnel

Only appropriately trained persons who are familiar with and understand the contents of this manual and all other pertinent product documentation are authorized to work on and with this product. In addition, these persons must have received safety training to recognize and avoid hazards involved. These persons must have sufficient technical training, knowledge and experience and be able to foresee and detect potential hazards that may be caused by using the product, by changing the settings and by the mechanical, electrical and electronic equipment of the entire system in which the product is used. All persons working on and with the product must be fully familiar with all applicable standards, directives, and accident prevention regulations when performing such work.

Intended Use

This product is intended for industrial use according to this manual.

The product may only be used in compliance with all applicable safety standard and local regulations and directives, the specified requirements and the technical data. The product must be installed outside the hazardous ATEX zone. Prior to using the product, you must perform a risk assessment in view of the planned application. Based on the results, the appropriate safety measures must be implemented. Since the product is used as a component in an entire system, you must ensure the safety of persons by means of the design of this entire system (for example, machine design). Any use other than the use explicitly permitted is prohibited and can result in hazards.

Product Related Information

Read and understand these instructions before performing any procedure with this device.

DANGER

HAZARD OF ELECTRIC SHOCK, EXPLOSION OR ARC FLASH

- Only appropriately trained persons who are familiar with and fully understand the contents of the present manual and all other pertinent product documentation and who have received all necessary training to recognize and avoid hazards involved are authorized to work on and with this device system.
- Installation, adjustment, repair and maintenance must be performed by qualified personnel.
- Verify compliance with all local and national electrical code requirements as well as all other applicable regulations with respect to grounding of all equipment.
- Only use properly rated, electrically insulated tools and measuring equipment.
- Do not touch unshielded components or terminals with voltage present.
- Prior to performing any type of work on the device system, block the motor shaft to prevent rotation.
- Insulate both ends of unused conductors of the motor cable.
- Do not short across the DC bus terminals or the DC bus capacitors or the braking resistor terminals.

Failure to follow these instructions will result in death or serious injury.

DANGER

HAZARD OF ELECTRIC SHOCK, EXPLOSION, OR ARC FLASH

Before performing work on the device system:

- Disconnect all power, including external control power that may be present. Take into account that the circuit breaker or main switch does not de-energize all circuits.
- Place a “Do Not Turn On” label on all power switches related to the device system.
- Lock all power switches in the open position.
- Wait 15 minutes to allow the DC bus capacitors to discharge.
- Verify the absence of voltage. (1)

Before applying voltage to the device system:

- Verify that the work has been completed and that the entire installation cannot cause hazards.
- If the mains input terminals and the motor output terminals have been grounded and short-circuited, remove the ground and the short circuits on the mains input terminals and the motor output terminals.
- Verify proper grounding of all equipment.
- Verify that all protective equipment such as covers, doors, grids is installed and/or closed.

Failure to follow these instructions will result in death or serious injury.

(1) Refer to the Verify the Absence of Voltage section in the installation manual of the product.

Damaged products or accessories may cause electric shock or unanticipated equipment operation.

⚠️⚠️ DANGER

ELECTRIC SHOCK OR UNANTICIPATED EQUIPMENT OPERATION

Do not use damaged products or accessories.

Failure to follow these instructions will result in death or serious injury.

Contact your local Schneider Electric sales office if you detect any damage whatsoever.

This equipment has been designed to operate outside of any hazardous location. Only install this equipment in zones known to be free of a hazardous atmosphere.

⚠️ DANGER

POTENTIAL FOR EXPLOSION

Install and use this equipment in non-hazardous locations only.

Failure to follow these instructions will result in death or serious injury.

Your application consists of a whole range of different interrelated mechanical, electrical, and electronic components, the device being just one part of the application. The device by itself is neither intended to nor capable of providing the entire functionality to meet all safety-related requirements that apply to your application. Depending on the application and the corresponding risk assessment to be conducted by you, a whole variety of additional equipment is required such as, but not limited to, external encoders, external brakes, external monitoring devices, guards, etc. As a designer/manufacturer of machines, you must be familiar with and observe all standards that apply to your machine. You must conduct a risk assessment and determine the appropriate Performance Level (PL) and/or Safety Integrity Level (SIL) and design and build your machine in compliance with all applicable standards. In doing so, you must consider the interrelation of all components of the machine. In addition, you must provide instructions for use that enable the user of your machine to perform any type of work on and with the machine such as operation and maintenance in a safe manner. The present document assumes that you are fully aware of all normative standards and requirements that apply to your application. Since the device cannot provide all safety-related functionality for your entire application, you must ensure that the required Performance Level and/or Safety Integrity Level is reached by installing all necessary additional equipment.

▲ WARNING

INSUFFICIENT PERFORMANCE LEVEL/SAFETY INTEGRITY LEVEL AND/OR UNINTENDED EQUIPMENT OPERATION

- Conduct a risk assessment according to EN ISO 12100 and all other standards that apply to your application.
- Use redundant components and/or control paths for all critical control functions identified in your risk assessment.
- Verify that the service life of all individual components used in your application is sufficient for the intended service life of your overall application.
- Perform extensive commissioning tests for all potential error situations to verify the effectiveness of the safety-related functions and monitoring functions implemented, for example, but not limited to, speed monitoring by means of encoders, short circuit monitoring for all connected equipment, correct operation of brakes and guards.
- Perform extensive commissioning tests for all potential error situations to verify that the load can be brought to a safe stop under all conditions.

Failure to follow these instructions can result in death, serious injury, or equipment damage.

Product may perform unexpected movements because of incorrect wiring, incorrect settings, incorrect data or other errors.

▲ WARNING

UNANTICIPATED EQUIPMENT OPERATION

- Carefully install the wiring in accordance with the EMC requirements.
- Do not operate the product with unknown or unsuitable settings or data.
- Perform a comprehensive commissioning test.

Failure to follow these instructions can result in death, serious injury, or equipment damage.

▲ WARNING**LOSS OF CONTROL**

- The designer of any control scheme must consider the potential failure modes of control paths and, for critical control functions, provide a means to achieve a safe state during and after a path failure. Examples of critical control functions are emergency stop, overtravel stop, power outage and restart.
- Separate or redundant control paths must be provided for critical control functions.
- System control paths may include communication links. Consideration must be given to the implications of unanticipated transmission delays or failures of the link.
- Observe all accident prevention regulations and local safety guidelines (1).
- Each implementation of the product must be individually and thoroughly tested for proper operation before being placed into service.

Failure to follow these instructions can result in death, serious injury, or equipment damage.

(1) For USA: Additional information, refer to NEMA ICS 1.1 (latest edition), Safety Guidelines for the Application, Installation, and Maintenance of Solid State Control and to NEMA ICS 7.1 (latest edition), Safety Standards for Construction and Guide for Selection, Installation and Operation of Adjustable-Speed Drive Systems.

The temperature of the products described in this manual may exceed 80 °C (176 °F) during operation.

▲ WARNING**HOT SURFACES**

- Ensure that any contact with hot surfaces is avoided.
- Do not allow flammable or heat-sensitive parts in the immediate vicinity of hot surfaces.
- Verify that the product has sufficiently cooled down before handling it.
- Verify that the heat dissipation is sufficient by performing a test run under maximum load conditions.

Failure to follow these instructions can result in death, serious injury, or equipment damage.

NOTICE**DESTRUCTION DUE TO INCORRECT MAINS VOLTAGE**

Before switching on and configuring the product, verify that it is approved for the mains voltage.

Failure to follow these instructions can result in equipment damage.

Related Documents

Use your tablet or your PC to quickly access detailed and comprehensive information on all our products on www.se.com.

The internet site provides the information you need for products and solutions:

- The whole catalog for detailed characteristics and selection guides,
- The CAD files to help design your installation, available in over 20 different file formats,
- All software and firmware to maintain your installation up to date,
- A large quantity of White Papers, Environment documents, Application solutions, Specifications... to gain a better understanding of our electrical systems and equipment or automation,
- And finally all the User Guides related to your drive, listed below:

Title of Documentation	Reference Number
Leaflet: Altivar Process customized drive solutions	998-19696726 (English)
Catalog: Altivar Process ATV600 variable speed drives	DIA2ED2140502EN (English), DIA2ED2140502FR (French)
ATV660 Handbook	NHA37110 (German), NHA37111 (English)
ATV680 Handbook	NHA37112 (German), NHA37113 (English)
Drive Systems – Installation manual	NHA37118 (German), NHA37119 (English), NHA37121 (French), NHA37122 (Spanish), NHA37123 (Italian), NHA37124 (Dutch), NHA37126 (Polish), NHA37127 (Portuguese), NHA37129 (Turkish), NHA37130 (Chinese)
ATV6●● Programming manual	EAV64318 (English), EAV64320 (French), EAV64321 (German), EAV64318PT (Portuguese), EAV64318RU (Russian), EAV64322 (Spanish), EAV64323 (Italian), EAV64324 (Chinese)
ATV6●● Modbus serial link manual (embedded)	EAV64325 (English)
ATV6●● Ethernet manual (embedded)	EAV64327 (English)
ATV6●● Ethernet IP - Modbus TCP manual (VW3A3720, 721)	EAV64328 (English)
ATV6●● BACnet MS/TP manual (VW3A3725)	QGH66984 (English)
ATV6●● PROFIBUS DP Manual (VW3A3607)	EAV64329 (English)
ATV6●● DeviceNet manual (VW3A3609)	EAV64330 (English)
ATV6●● PROFINET manual (VW3A3627)	EAV64331 (English)
ATV6●● CANopen manual (VW3A3608, 618, 628)	EAV64333 (English)
ATV6●● POWERLINK Manual (VW3A3619)	PHA99690 (English)
ATV6●● Communication parameters	EAV64332 (English)
ATV6●● Embedded safety function manual	EAV64334 (English)
ATV6●● & ATV9●● ATEX manual	NVE42416 (English)
SoMove: FDT	SoMove_FDT (English, French, German, Spanish, Italian, Chinese)
Altivar Process ATV6●● DTM	ATV6xx_DTM_Library_EN (English), ATV6xx_DTM_Library_FR (French), ATV6xx_DTM_Library_DE (German), ATV6xx_DTM_Library_SP (Spanish), ATV6xx_DTM_Library_IT (Italian), ATV6xx_DTM_Library_CN (Chinese),
Application note: ATV600 Multi-drives booster control optimized	QGH36060 (English)
Application note: ATV600 Multi-masters booster control pressure feedback with cervice continuity	QGH36061 (English)
Application Note: ATV600 Multi-Drives Standard Level Control	QGH36059 (English)
Application note: ATV600 Multi-masters with optimized level control	EAV64367 (English)
Recommended Cybersecurity Best Practices	CS-Best-Practices-2019-340 (English)

You can download these technical publications and other technical information from our website at www.se.com.

Environmental Data Program



Next-level transparency for better-informed product choices

The **Environmental Data Program** is a framework for how we measure, categorize, and compare the environmental attributes and footprint of our products.

Using a rigorous, fact-based methodology, the program provides environmental data from across the product lifecycle.

With this transparent, verified data, customers and partners are empowered to make conscious environmental choices and accurately evaluate and report on sustainability performance.

All our hardware offers have an associated environmental data available on se.com product pages.

Carbon footprint (kg CO2 eq) **91745**

One methodology is used to calculate the carbon footprint of all our products to enable simple comparison.



Learn more about the [Environmental Data Program](#)

Use Better: How sustainable a product is, including environmental footprint, materials and substances, packaging, and energy efficiency.

Recycled Cardboard Packaging	Yes
REACH and RoHS compliant	Yes

Use Longer: How a product's life time can be effectively extended in terms of reparability and updatability.

Firmware updatable	Yes
Repairability Index	Rating "A"

Use Again: How a product can be reused, from dismantling and remanufacturing to recyclability and manufacturer take back.

Recyclable potential	77%
Take-back	Yes

Terminology

The technical terms, terminology, and the corresponding descriptions in this manual normally use the terms or definitions in the relevant standards.

In the area of drive systems this includes, but is not limited to, terms such as **error**, **error message**, **failure**, **fault**, **fault reset**, **protection**, **safe state**, **safety function**, **warning**, **warning message**, and so on.

Among others, these standards include:

- IEC 61800 series: Adjustable speed electrical power drive systems
- IEC 61508 Ed.2 series: Functional safety of electrical/electronic/programmable electronic safety-related
- EN 954-1 Safety of machinery - safety-related parts of control systems
- EN 61439 series: Low-voltage switchgear and controlgear assemblies
- ISO 13849-1 & 2 Safety of machinery - safety related parts of control systems
- IEC 61158 series: Industrial communication networks - Fieldbus specifications
- IEC 61784 series: Industrial communication networks - Profiles
- IEC 60204-1: Safety of machinery - Electrical equipment of machines – Part 1: General requirements

In addition, the term **zone of operation** is used in conjunction with the description of specific hazards, and is defined as it is for a **hazard zone** or **danger zone** in the EC Machinery Directive (2006/42/EC) and in ISO 12100-1.

Contact us

Select your country on www.se.com/contact.

Schneider Electric Industries SAS

Head Office

35, rue Joseph Monier

92500 Rueil-Malmaison

France

Drive Systems

What's in This Part

Overview	21
ATV680 - Low Harmonic Drive Systems	22
Expandability	26

Overview

Market Segment	Water and waste water Oil & gas Mining, minerals & metals Food & beverage
-----------------------	--



Drive Systems	Frequency inverter as enclosure unit for speed control of asynchronous and synchronous motors.	
Brief description	Enclosure unit, alternatively in the standard design, with additional adaptations or as a customized solution	Low Harmonic, alternatively in the standard design, with additional adaptations or as a customized solution
Special features	Compact Drive Systems with integrated line reactor to reduce the current harmonics THDi 32...48 %	Low Harmonic Drive Systems with active mains rectifier to reduce the current harmonics THDi < 5 %
Protection degree	IP23 standard design of the enclosure IP54 optional design of the enclosure	
Power range	110 / 90 up to 800 / 630 kW	
Voltage ranges	<ul style="list-style-type: none"> • 3 AC 380 V -10 % ... 415 V +6 % • 3 AC 400 V -10 % ... 415 V +10 % 	<ul style="list-style-type: none"> • 3 AC 440 V ±10 % • 3 AC 480 V ±10 %
Mains frequency	50/60 Hz +/- 5 %	
Output frequency	0.1...500 Hz	
Control method	Asynchronous motor: Variable load torque, constant load torque, energy saving	Synchronous motor: PM (permanent magnet) motor
Interfaces	Operating panel in the enclosure door, control terminals inside the enclosure, control terminals can be extended, fieldbus connection via Ethernet or Modbus, saving the parameters via USB interface at the keypad	
References	ATV660●●●●●X1	ATV680●●●●●X1
Configuration tool	Fully configurable with Altivar Process Drive Systems Configurator: Altivar Process Drive Systems Configurator Tool.	
Further reading	You can find detailed information in the "Altivar Process ATV660 Handbook" and on www.se.com .	You will find detailed information in this document.

ATV680 - Low Harmonic Drive Systems

What's in This Chapter

General Information ATV680	23
Enclosure Design 400 V	24

General Information ATV680

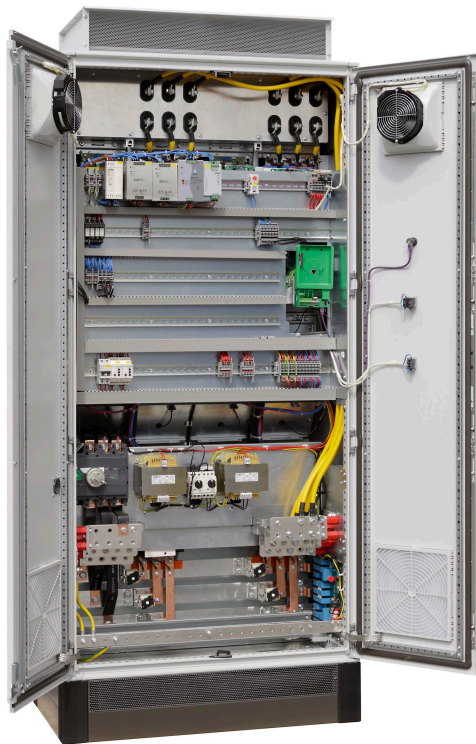

Low Harmonic Drive Systems as enclosure unit for speed control of asynchronous and synchronous motors.

Concept

The ATV680 Low Harmonic Drive Systems are used when drives should contain mains harmonics particularly low.

In comparison with the classic circuit structure of active mains rectifiers, the 3-level technology allows an increase of the switching frequency and the current load is reduced at the same time. This new technology reaches a total distortion factor THD (i) of around 2 % and thus fulfills the requirements according to IEEE 519 of THD(i) < 5 % also in case of distorted mains. Additionally, the $\cos \Phi \approx 1$ in each load situation helps to reduce the load of the mains.

The modular construction makes it possible to adapt the enclosure unit to the individual requests. It makes the planning easy and allows a quick installation and commissioning of the drive.

Basic equipment

The basic equipment contains active infeed modules and their filter components as well as frequency inverter modules, semiconductor fuses, a main switch, a dv/dt filter choke (from 200 kW) for protection of the motor and spacious mains and motor bars for connection of the power cables. The design is based on the standard enclosure system PanelSeT SFN with an graphical operating panel integrated into the enclosure door.

The control is located on a spacious control panel. It provides compact dimensions, nevertheless it is enough space for additional extensions and accessibility in case of maintenance.

Altivar Process Drive Systems Configurator

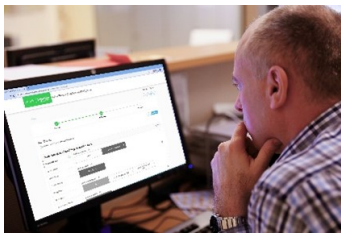

All-in-one tool to configure individual Drive Systems. It allows quick customization of Configured Drive Systems (CTO) to meet your specific requirements. Thanks to pre-defined options, the CTO variant allows a significant reduction of the production time for individually adapted drives, ready to connect.

- 4 ranges ATV660, ATV680, ATV960, ATV980
- 90 ... 800 kW @400 V
- 110 ... 900 kW @480V
- Tested, validated, documented, and pre-set parameters

[Click here to start the Altivar Process Drive Systems Configurator Tool.](#)

Device features

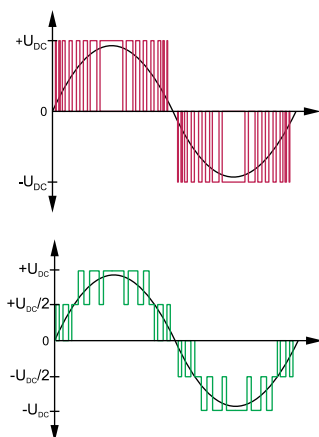

Enhanced motor lifetime due to 3-level concept

The 3-level technology of the active mains rectifier reduces the voltage load at the motor significantly compared to other Low Harmonic frequency inverters. The gliding adaptation of the DC link voltage makes a major contribution to extend the motor lifetime.

Reduced losses by 3-level concept

In comparison with the classic circuit structure of active mains rectifiers, the switching frequency is increased and the current load is reduced at the same time when using 3-level technology. So the losses of the whole system are significantly reduced.

Compact dimensions due to 3-level concept

A significant advantage of the 3-level technology becomes clear when considering the dimensions of the integrated filter components. Due to the increased switching frequency and the location inside the forced cooling air channel, the dimensions of the filter could be almost halved

Enclosure Design 400 V

ATV680 - General technical data			
Mains voltage	<ul style="list-style-type: none"> • 3 AC 380 V -10 % ... 415 V +6 % • 3 AC 400 V -10 % ... 415 V +10 % • 3 AC 440 V ±10 % • 3 AC 480 V ±10 % 50/60 Hz ±5 % for TT, TN-C or TN-S Other voltages and mains topologies on request.		
Maximum current	Normal duty (ND): 110 % for 60 s per 10 minutes Heavy duty (HD): 150 % for 60 s per 10 minutes		
Ambient temperature	-10...+50 °C (below 0 °C with additional enclosure heating, above +40 °C with derating) You will find further information at chapter Maximum Ambient Temperature , page 51.		
Standard equipment	Enclosure system PanelSeT SFN in RAL 7035, protection degree IP23, graphical operating panel in the enclosure door, Low Harmonic Drive System with active mains rectifier to reduce the current harmonics THDi < 5 %, mains and motor terminals, cable entry from bottom		
Interfaces	Pluggable control terminals, fieldbus connection via Ethernet or Modbus		
Possible customizations	<table border="0"> <tr> <td> <ul style="list-style-type: none"> • Increased protection degree IP54 • Enclosure plinth for basic device • Connection enclosure cable from top/bottom • Enclosure lighting • Enclosure heating • Key switch "local/remote" • Ethernet port on front door • Digital and analog I/O card • Relay output card • Communication cards for various fieldbus systems • STO - SIL 3 Stop category 0 or 1 • Front display module (FDM) • Modified wiring colors • Remote monitoring • Seaworthy packaging • Differing mains voltages • Design without main switch </td> <td> <ul style="list-style-type: none"> • Increased short-circuit strength (100 kA) • Indicator lamps on front door • Motor temperature monitoring • Bearing temperature monitoring • dv/dt filter choke • Motor heating • Circuit breaker • Undervoltage coil for circuit breaker 230 V • Motor for circuit breaker 230 V • Safety labels in local language • Air intake from back • Differing enclosure colors • Customized documentation • Customized labeling • Design for IT mains • Motor contactor • ... </td> </tr> </table>	<ul style="list-style-type: none"> • Increased protection degree IP54 • Enclosure plinth for basic device • Connection enclosure cable from top/bottom • Enclosure lighting • Enclosure heating • Key switch "local/remote" • Ethernet port on front door • Digital and analog I/O card • Relay output card • Communication cards for various fieldbus systems • STO - SIL 3 Stop category 0 or 1 • Front display module (FDM) • Modified wiring colors • Remote monitoring • Seaworthy packaging • Differing mains voltages • Design without main switch 	<ul style="list-style-type: none"> • Increased short-circuit strength (100 kA) • Indicator lamps on front door • Motor temperature monitoring • Bearing temperature monitoring • dv/dt filter choke • Motor heating • Circuit breaker • Undervoltage coil for circuit breaker 230 V • Motor for circuit breaker 230 V • Safety labels in local language • Air intake from back • Differing enclosure colors • Customized documentation • Customized labeling • Design for IT mains • Motor contactor • ...
<ul style="list-style-type: none"> • Increased protection degree IP54 • Enclosure plinth for basic device • Connection enclosure cable from top/bottom • Enclosure lighting • Enclosure heating • Key switch "local/remote" • Ethernet port on front door • Digital and analog I/O card • Relay output card • Communication cards for various fieldbus systems • STO - SIL 3 Stop category 0 or 1 • Front display module (FDM) • Modified wiring colors • Remote monitoring • Seaworthy packaging • Differing mains voltages • Design without main switch 	<ul style="list-style-type: none"> • Increased short-circuit strength (100 kA) • Indicator lamps on front door • Motor temperature monitoring • Bearing temperature monitoring • dv/dt filter choke • Motor heating • Circuit breaker • Undervoltage coil for circuit breaker 230 V • Motor for circuit breaker 230 V • Safety labels in local language • Air intake from back • Differing enclosure colors • Customized documentation • Customized labeling • Design for IT mains • Motor contactor • ... 		
Standards	CE, EAC, RCM, ATEX, IEEE 519 (THDi < 5 %), RFI filter for second "industrial environment" C3 integrated		

Type	Size	Motor rating (ND / HD)	Output current (ND / HD)	Dimensions		
				Width	Depth ⁽¹⁾	Height
ATV680C11●4X1	1a	110 kW / 90 kW	211 A / 173 A	600 mm	600 mm	2150 mm
ATV680C13●4X1		132 kW / 110 kW	250 A / 211 A	600 mm	600 mm	2150 mm
ATV680C16●4X1		160 kW / 132 kW	302 A / 250 A	600 mm	600 mm	2150 mm
ATV680C20●4X1	2a	200 kW / 160 kW	370 A / 302 A	1000 mm	600 mm	2150 mm
ATV680C25●4X1		250 kW / 200 kW	477 A / 370 A	1000 mm	600 mm	2150 mm
ATV680C31●4X1		315 kW / 250 kW	590 A / 477 A	1000 mm	600 mm	2150 mm
ATV680C35●4X1	3a	355 kW / 280 kW	660 A / 520 A	1600 mm	600 mm	2150 mm
ATV680C40●4X1		400 kW / 315 kW	730 A / 590 A	1600 mm	600 mm	2150 mm
ATV680C45●4X1		450 kW / 355 kW	830 A / 660 A	1600 mm	600 mm	2150 mm
ATV680C50●4X1		500 kW / 400 kW	900 A / 730 A	1600 mm	600 mm	2150 mm
ATV680C56●4X1	4a	560 kW / 450 kW	1020 A / 830 A	2000 mm	600 mm	2150 mm
ATV680C63●4X1		630 kW / 500 kW	1140 A / 900 A	2000 mm	600 mm	2150 mm
ATV680C71●4X1	5a	710 kW / 560 kW	1260 A / 1020 A	2600 mm	600 mm	2150 mm
ATV680C80●4X1		800 kW / 630 kW	1420 A / 1140 A	2600 mm	600 mm	2150 mm
(1) Total depth including door handle and switch handle: 664 mm						

Expandability

What's in This Chapter

Introduction.....	27
Predefined Customizations	27
Individual Customizations	27
Type designation	28

Introduction

The Altivar Process Drive Systems are the result of our many years of experience in the field of electronic drives. Moreover we provide especially designed expansion options for a various range of applications. Our worldwide, certified manufacturing sites and the local engineering teams allow a global offer.

Predefined Customizations



Due to the predefined customizations the Altivar Process Drive System can be adapted easily and quick to the customer requirements. Besides, this allows minimal delivery time for an individually adapted enclosure ready to connect.

Certainly the Altivar Process Drive Systems can be ordered also in the basic design, which is already extensive equipped, without any customization.

Predefined customizations are:

- Increased protection degree IP54
- Enclosure plinth for basic device
- Connection enclosure cable from top/ bottom
- Enclosure lighting
- Enclosure heating
- Key switch "local/remote"
- Ethernet port on front door
- Digital and analog I/O card
- Relay output card
- Communication cards for various fieldbus systems
- STO - SIL 3 Stop category 0 or 1
- Front display module (FDM)
- Indicator lamps on front door
- Motor temperature monitoring
- Bearing temperature monitoring
- dv/dt filter choke
- Motor heating
- Circuit breaker
- Undervoltage coil for circuit breaker
- Motor for circuit breaker
- Safety labels in local language
- Modified wiring colors
- Remote monitoring
- Seaworthy packaging
- Differing mains voltages
- Design without main switch
- Increased short-circuit strength (100 kA)
- Air intake from back
- Differing enclosure colors
- Customized documentation
- Customized labeling
- Design for IT mains
- Motor contactor
- Integrated control functions
- ...

Individual Customizations



Due to our substantial know-how and the high flexibility in performing projects, it is possible to realize unique system solutions. They are individually adapted to the customers demands.

Typical customizations:

- Multi drives (several frequency inverters in an enclosure composition)
- Differing cooling system
- Different enclosure system
- Differing dimensions
- ...

Type designation

The type designation of the Altivar Process Drive Systems consists of several points of signs (characters and figures). The meaning of each point is illustrated in the following example.

		ATV	680	C16	Q4	X1
Product	Description					
ATV	Altivar					
Segments						
680	Low Harmonic Drive Systems					
Drive power						
C11...C80	110 / 90 kW ... 800 / 630 kW					
Mains voltage						
Q4	3 AC 380 V -10 %...415 V +6 % (+10 %)					
R4	3 AC 440 V ±10 %					
T4	3 AC 480 V ±10 %					
Design variant						
X1	Europe CE					
X3	China CCC					

General Specification

What's in This Part

Quality.....	30
Mains Conditions	35
Preliminary Instructions	39

Quality

What's in This Chapter

Overview	31
System concept ATV680	31
CE Marking	32
Installation Regulations	32
Safety of Machinery	33
EMC Product Standard for Power Device Systems EN 61800-3	33
Use In Industrial Environment	34

Overview

Altivar frequency inverters use modern components and solutions for the control of asynchronous three-phase motors and synchronous three-phase motors. This enables an extremely compact design and user-friendly device features.

The ATV680 includes an active input bridge and leads a sinusoidal mains current. So it is an alternative to active and passive filters.

State-of-the-art components, a new control concept as well as a top-quality filter module reduce the total harmonic distortion THD(i) of the frequency inverter to a value less than 2...5 % and by this way it fulfills the requirements according to the recommendations in IEEE 519 to reduce the current harmonics in the mains.

Also in case of operation with partial load (from 30 % P_n) the ATV680 leads a sinusoidal mains current with a power factor cos Phi ≈ 1.

Our high degree of quality awareness ranges from the basic requests in the product specification over the development of the cooling system, of the mechanical design, of the electrical circuit diagram and the individual functions up to the production of the device. This process quality level is also long-term guaranteed by means of the corresponding quality assurance systems in the individual business processes and is certified every year by independent authorities according to DIN EN ISO 9001.

The Altivar Process Drive Systems fulfil the relevant international standards and regulations.

System concept ATV680

Altivar Process Drive Systems are manufactured according to the selected design (basic device and options) and are delivered as a drive unit ready to connect. They include the functionally necessary components.

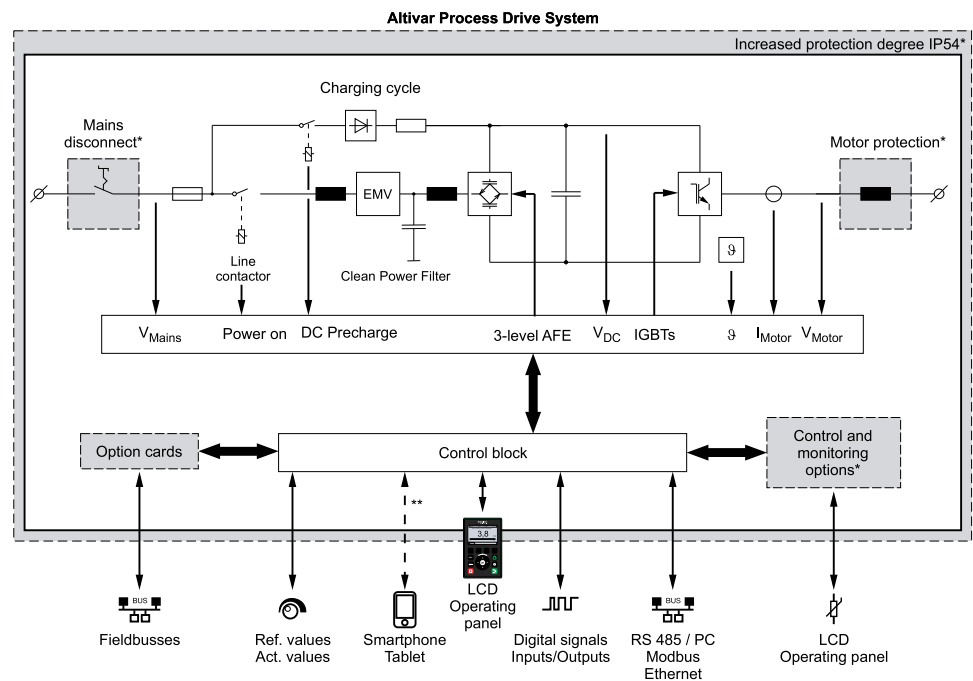

* Optionally selectable
 ** With optional WIFI module (TCSEGWB13FA0)

Depending on the local conditions and the requests on the drive the basic design can be supplemented by options. Options for the power path, options for control and operation as well as mechanical options are available. They are all integrated into the enclosure unit but they may cause a change of dimensions.

CE Marking

The frequency inverters have a CE marking on the rating plate. However, to achieve the corresponding limits it is necessary to observe the installation regulations, superior and regional standards and directives as well as the directives listed below.

All devices and drives of the electric drive engineering may cause electromagnetic interferences and otherwise they may be influenced by such interferences. Therefore, they are subject to the **EMC directive 2014/30/EC**.

The frequency inverters have an operating voltage which is clearly in the range of 50...1000 V AC or 75...1500 V DC. Therefore, they are also subject to the **Low Voltage Directive 2014/35/EC**.

Because of the EMC filters which are built into the frequency inverters they are in conformity with **EN 61800-3** and **EN 61800-5-1**.

Frequency inverters are not considered as stand-alone machines according to the Machinery Directive 2006/42/EC. They have to be accounted as component of the closed functional safety system.

Limit values

This product meets the EMC requirements according to the standard IEC 61800-3 if the measures described in this manual are implemented during installation.

If the selected composition (product itself, mains filter, other accessories and measures) does not meet the requirements of category C1, the following information applies as it appears in IEC 61800-3:

⚠ WARNING

RADIO INTERFERENCE

In a domestic environment this product may cause radio interference in which case supplementary mitigation measures may be required.

Failure to follow these instructions can result in death, serious injury, or equipment damage.

Installation Regulations

- The frequency inverters have a RFI filter for grounded mains built-in.
- Take care of good HF connection between motor cable screen and filter.
- Use of shielded motor cables, proper connection of the motor cables on both ends or proper laying in a metallic, closed and interconnected cable conduit.
- In case of high motor cable lengths a corresponding dv/dt filter choke is required.
- Use shielded control cables and connect them correctly.
- Ground the frequency inverter for human protection.
- Consider the protective separation (PELV) when preparing signal wires and coupling relays.
- Lay the motor cables separate from other cables, especially from the signal wires.

NOTE: Further information is given in the installation manual.

Safety of Machinery

For the functional safety and stop categories the function "Safe Torque Off (STO)" has been integrated. So an optimal adaptation of the drive to the required safety category for the machine is possible.

NOTE: You will find further information about this function in chapter Safe Torque Off (STO), page 135.

For all selectable safety options the implementation of external safety-relevant contacts is provided. So the Altivar Process does not act as a closed functional safety system in terms of the Machine directive and safety standards EN/IEC 61508, ISO 13849-1 and NF EN 62061. It has to be accounted as component in any case.

EMC Product Standard for Power Device Systems EN 61800-3

For frequency inverter devices the product standard EN/IEC 61800-3 edition 1 and 2 appeared. It has first priority over the existing general standards (generic standards). If a device is installed into another device for which a separate EMC product standard exists, then this standard applies.

The aim of the **EMC directive 2014/30/EEC** is the ability of electric and electronic installations to operate satisfactorily in their electromagnetic environment without influencing the environment or other loads therein.

Therefore, the PDS (Power Device Systems) product standard contains both limits for admissible interferences and requirements for the necessary interference resistance.

The power device standard EN 61800-3 covers the complete device from the mains supply to the motor shaft.

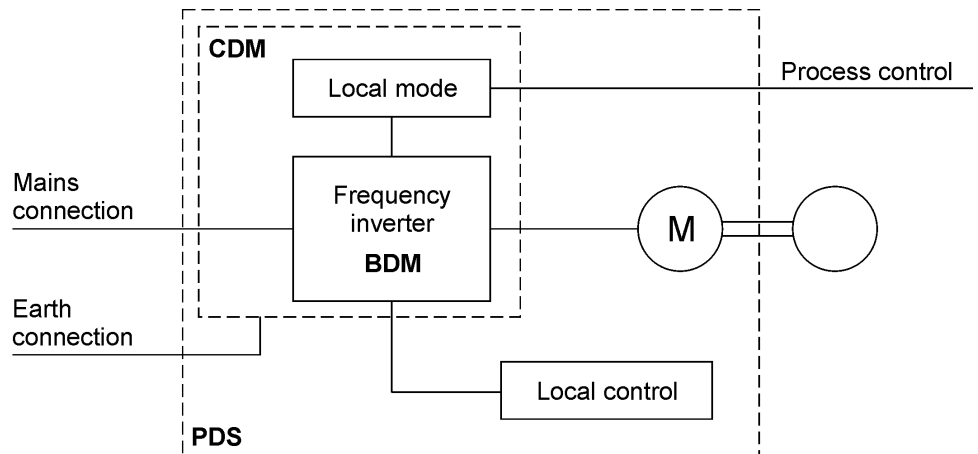

- BDM: Base-Device-Module** Basic device consisting of the power part and the control electronics (e.g. frequency inverter - built-in unit)
- CDM: Complete-Device-Module** Device modules consisting of BDM (basic device) and extensions, if existing (e.g. enclosure including main switch, circuit breaker, line contactor, filter components, power terminals, ...)
- PDS: Power-Device-System** Device system consisting of CDM (device module) and motor, motor cable, local control, power transformer, ... (e.g. the complete electric device of a machine)

The differentiation in respect of the sales method and the range of use is essential for the handling of frequency inverters.

Use In Industrial Environment

The standard refers to these application areas as "second environment". These are areas which are separated from the public mains by means of an own transformer.

The user has to take care that the suppression components recommended by the manufacturer are used and that the introductions of the manufacturer are observed. Moreover, the user has to take care that strong interferences do not couple into neighboring low-voltage mains.

If the neighboring mains is a public mains with residential areas, the limits 66-56/56/60 dB(μV) quasi-peak apply. In case of industrial mains the higher limits 79/73/73 dB(μV) quasi-peak can be used.

Furthermore, it is necessary to enhance the suppression of interferences if other devices are influenced. The operator of the plant is responsible for this improvement.

The limits for immunity are much stricter because they are based on a generally higher level of interferences.

Category C3

Use in industrial environments

Limits for interferences	Line-conducted interferences	Radiation
For devices with a size ≤ 100 A the admissible limits for interferences are 100/86/90-70 dB(μV) quasi-peak and 50/60 dB(μV/m) at a distance of 10 m (class A group 2).	<p>dBμV (QP)</p> <p>100 86 90 70 0.15 0.5 5 30 MHz</p>	<p>dBμV/m (QP)</p> <p>50 60 30 230 1000 MHz</p>
For devices with a size > 100 A the admissible limits for interferences are 130/125/115 dB(μV) quasi-peak and 50/60 dB(μV/m) at a distance of 10 m (class A group 2).	<p>dBμV (QP)</p> <p>130 125 115 0.15 0.5 5 30 MHz</p>	<p>dBμV/m (QP)</p> <p>50 60 30 230 1000 MHz</p>

Category C4

Use in industrial environments for devices > 1000 V or > 400 A

For these devices are no limits defined. An EMC concept has to be compiled within project planning.

IT mains

In case of non-grounded mains it is usually not possible to keep the limits. Filter capacitors make detection of insulation faults difficult and thus they interfere with the concept of a floating power supply. However, filters that are developed especially for IT mains can be used because they also cause a high reduction of the conducted interferences in non-grounded mains.

NOTE: The basic requirements for compliance with the relevant limits are the observance and compliance of the installation requirements and a correct customization of the Device System.

Mains Conditions

What's in This Chapter

Mains Voltage	36
Non-grounded Mains	36
Radio Interferences	37
Mains Impedance / Short-circuit Current	37
Switching Rate	37

Mains Voltage

The Altivar Process Drive Systems are designed for standard industrial mains TT and TN with following mains voltage:

- 3 AC 380 V -10 % ... 415 V +6 %
- 3 AC 400 V -10 % ... 415 V +10 %
- 3 AC 440 V ±10 %
- 3 AC 480 V ±10 %

NOTE: Other voltages and the use in IT mains or "Corner grounded networks" are available on request.

The mains voltage must comply with the requirements according to IEC 60038 and EN 50160:

- Unbalance between phases: < 2 %
- Total harmonic factor THD(v): < 10 %
- Maximum single harmonic: < 5 %

<i>NOTICE</i>
DESTRUCTION DUE TO INCORRECT MAINS VOLTAGE
Before switching on and configuring the product, verify that it is approved for the mains voltage.
Failure to follow these instructions can result in equipment damage.

Undervoltage behavior

In case of short-time mains voltage drops outside the specified tolerance, operation is still possible.

If the mains voltage does not return within the specified time, an undervoltage shut-down occurs.

Mains undervoltage	Restriction
-10 % of nominal voltage	Starting the drive and continuous operation possible ⁽¹⁾
-15 % of nominal voltage	Starting the drive and operation ⁽¹⁾ for 10 s per 100 s possible
-20 % of nominal voltage	Operation ⁽¹⁾ for less than 1 s possible
-30 % of nominal voltage	Operation ⁽¹⁾ for less than 0.5 s possible
(1) With nominal current	

Non-grounded Mains

The Altivar Process Drive Systems can be prepared for the use in non-grounded mains (IT mains or "Corner grounded networks").

Radio Interferences

The Altivar Process Drive Systems include a radio frequency interference filter as standard. This filter fulfils the requirements for category "C3 – industrial environments" according to EN/IEC 61800-3 (in the past: EN 55011 class A group 2).

Limit values

This product meets the EMC requirements according to the standard IEC 61800-3 if the measures described in this manual are implemented during installation.

If the selected composition (product itself, mains filter, other accessories and measures) does not meet the requirements of category C1, the following information applies as it appears in IEC 61800-3:

▲ WARNING
RADIO INTERFERENCE
In a domestic environment this product may cause radio interference in which case supplementary mitigation measures may be required.
Failure to follow these instructions can result in death, serious injury, or equipment damage.

Mains Impedance / Short-circuit Current

The Altivar Process Drive Systems are designed considering a maximal and minimal permitted mains short-circuit current of the supply (values see "Technical data" of the respective frequency inverter).

These frequency inverters can be designed for higher mains short-circuit currents on request. You will find information about the short-circuit protection at chapter Mains Connection, page 82.

Switching Rate

Altivar Process Drive Systems are equipped with a main switch for disconnecting the applied mains voltage.

In case of frequent start/stop requests it is recommended to realize them by means of the digital control inputs (or via a serial bus) directly to the electronics of the inverter.

Optionally the mains separation can be realized by a circuit breaker with motor.

NOTE: By means of the certificated control inputs $\overline{\text{STOA}}$ and $\overline{\text{STOB}}$ a "Safe Torque Off" of the drive is considering the safety category according to ISO 13849-1 (and IEC/EN 61800-5-2). Disconnecting the mains supply or the motor is therefore not required.

Inverter control	Switching rate ATV680
Mains voltage switched external	Max. 60 switching operations per hour
Mains voltage switched internal: <ul style="list-style-type: none"> • Main switch (standard) • Circuit breaker (option) • Circuit breaker with motor (option) 	Max. 10 switching operations per hour Max. 10,000 switching operations total
Start / Stop requests via digital inputs with active energy saving function "Stop and Go" ⁽¹⁾	Max. 60 switching operations per hour
Start / Stop requests via digital inputs without energy saving function "Stop and Go" ⁽¹⁾	Arbitrary
Release / Lock via STO inputs with active energy saving function "Stop and Go" ⁽¹⁾	Max. 60 switching operations per hour
Release / Lock via STO inputs without energy saving function "Stop and Go" ⁽¹⁾	Arbitrary
(1) The energy saving function "Stop and Go" is activated by default.	

NOTE: The device fans are automatically controlled depending on the start/stop request.

If the power stage is disabled unintentionally, for example as a result of power outage, errors or functions, there is a possibility that the motor is no longer decelerated in a controlled way.

<p>⚠ WARNING</p> <p>UNANTICIPATED EQUIPMENT OPERATION</p> <p>Verify that movements without braking effect does not result in unsafe conditions.</p> <p>Failure to follow these instructions can result in death, serious injury, or equipment damage.</p>
--

Preliminary Instructions

What's in This Chapter

Responsibility	40
Installation Site.....	40
Increased Motor Speed.....	40
Overvoltage Protective Circuit	41
Residual Current Circuit Breaker	41
Automatic Restarting	42
Locking of the Frequency Inverter	42
Stop and Go Function	43
Connecting and Disconnecting the Motor	43
Multi-motor Operation	43
Operation of ATEX Motors	44

Responsibility

All stated connection recommendations and planning remarks are to be taken merely as suggestions which must be adapted to the local conditions and regulations concerning installation and usage.

This applies especially to the functional safety regulations for machines, the EMC regulations and the general regulations for human protection.

Installation Site

The drives are qualified for vertical installation in electrical operating rooms as well as in the area of production facilities.

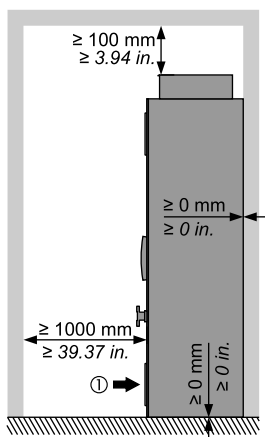

- Observe the specified minimum distances. Mounting the Drive Systems side by side or back to back is allowed.
 - Install the drive vertically on a non-combustible, solid and vibration-free ground.
 - Take care of compliance with the ambient conditions.
 - Take care that the air exchange is sufficient for dissipation of the lost heat during operation.
- ① Air inflow temperature: -10...+50 °C (14...122 °F) (below 0 °C (32 °F) with additional enclosure heating, above +40 °C (104 °F) with derating)

NOTE: At enclosure design IP54 the ATV680 frequency inverter is qualified for pollution degree 3 according to EN 61800-5-1.

NOTE: Further information is given in the installation manual.

This equipment has been designed to operate outside of any hazardous location. Only install this equipment in zones known to be free of a hazardous atmosphere.

⚠ DANGER

POTENTIAL FOR EXPLOSION

Install and use this equipment in non-hazardous locations only.

Failure to follow these instructions will result in death or serious injury.

Increased Motor Speed

With the Altivar Process Drive Systems it is possible to control the rotational speed of motors from 0.1...500 Hz.

Overvoltage Protective Circuit

The AC and DC control circuits must be protected against overvoltage. Use flyback diodes for DC control circuits.

For AC control circuits, RC circuits are advisable because they can reduce the peak overvoltage and the rise time while varistors only reduce the peak voltage.

NOTICE

INOPERATIVE CONTROL CIRCUITS

Verify that all inductances such as relays, contactors, external brakes, etc. are equipped with appropriate overvoltage protection circuits.

Failure to follow these instructions can result in equipment damage.

Residual Current Circuit Breaker

Frequency inverters, especially those with additional EMC filters and shielded motor cables, lead an increased leakage current against ground.

The leakage current depends on:

- The length of the motor cable
- The type of laying and whether the motor cable is shielded or not
- The set pulse frequency
- The use of an additional radio frequency interference filter
- The grounding of the motor at its installation place (grounded or non-grounded)

Depending on the conditions, the leakage current of plants with high cable lengths can be absolutely higher than 100 mA !

The built-in residual current detection has no current-limiting effect. It only helps to protect the drive and is no human protection.

Particularly because of the capacitors of the radio frequency interference filter, an unintentional triggering of a residual current circuit breaker may occur at the moment of switching on. As well, the ground capacitances may cause an incorrect triggering during operation. On the other hand, it is possible that the triggering is blocked by means of DC components which are caused by the mains rectification at the input of the inverter.

Direct current can be introduced in the protective ground conductor of this device. If a residual current device (RCD / GFCI) or a residual current monitor (RCM) is used for additional protection against direct or indirect contact, the following specific types must be used:

⚠ WARNING

DIRECT CURRENT CAN BE INTRODUCED INTO THE PROTECTIVE GROUND CONDUCTOR

Use a Type B Residual Current Device (RCD / GFCI) or a Residual Current Monitor (RCM) that has approval for use with frequency inverters and is sensitive to all types of current.

Failure to follow these instructions can result in death, serious injury, or equipment damage.

Further conditions for use of a residual current device:

- The device has an increased leakage current at the moment power is applied. Use a residual current device (RCD / GFCI) or a residual current monitor (RCM) with a response delay.
- High-frequency currents must be filtered.

NOTE: Protect the other loads by means of a separate residual current circuit breaker.

Automatic Restarting

This function increases the availability, especially for drives that are not integrated into the plant control via a fieldbus system. Depending on the parameterization, the frequency inverter can automatically start-up again after each mains switch-on or mains recurrence.

Locking of the Frequency Inverter

Altivar Process Drive Systems include the standard protective function "Safe Torque Off (STO)", which helps to prevent any unintended start-up of the motor. This function fulfills, when correctly wired, the machine standard ISO 13849-1 Performance level PL e, the IEC/EN 61508 Safety integrity level SIL 3 standard for functional safety and the power drive system standard IEC/EN 61800-5-2.

NOTE: You will find further information in the Safety Function Manual (EAV64334).

The safety function STO (Safe Torque Off) does not remove power from the DC bus. The safety function STO only removes power to the motor. The DC bus voltage and the mains voltage to the drive are still present.

⚡⚠ DANGER

HAZARD OF ELECTRIC SHOCK

- Do not use the safety function STO for any other purposes than its intended function.
- Use an appropriate switch, that is not part of the circuit of the safety function STO, to disconnect the product from the mains power.

Failure to follow these instructions will result in death or serious injury.

When the safety function STO is triggered, the power stage is immediately disabled. In the case of vertical applications or external forces acting on the motor shaft, you may have to take additional measures to bring the motor to a standstill and to keep it at a standstill when the safety function STO is used, for example, by using a service brake.

▲ WARNING

INSUFFICIENT DECELERATION OR UNINTENDED EQUIPMENT OPERATION

- Verify that using the safety function STO does not result in unsafe conditions.
- If standstill is required in your application, ensure that the motor comes to a secure standstill when the safety function STO is used.

Failure to follow these instructions can result in death, serious injury, or equipment damage.

Stop and Go Function



All Altivar Process Drive Systems include the energy saving function "Stop and Go".
When the frequency inverter gets a stop or lock request, the own consumption is clearly decreased by reducing the DC link voltage. With the next start request the DC link is charged and the motor can start-up again.

NOTE: For applications where a start delay of 1...2 s is undesired, this energy saving function can be also deactivated.

Connecting and Disconnecting the Motor

Alternatively to the use of the control terminal STO "Safe Torque Off" a safety switch or a motor contactor can be installed to connect and disconnect the motor – Design on request.

After connection the motor restarts by means of the function "Catch on the fly".

Multi-motor Operation

With Altivar Process Drive Systems it is possible to operate several motors at one output.

For pumps (centrifugal pumps) and fan applications, however, observe the following:

- The sum of the nominal currents has to be less than the nominal current of the inverter.
- A different speed control is not possible.
- The total motor cable length has to be taken into consideration.
- No high starting torque is available.
- The inverter does not provide individual motor overload protection.
- Autotuning is not possible (but also not necessary).
- Activation of individual motors is only permitted when the starting current remains less than the maximum inverter current.

Operation of ATEX Motors

If you want to operate an explosion-protected motor (ATEX) with this drive system, you must use the option "Motor monitoring PTC with ATEX certificate".

NOTE: You will find further information about the operation of ATEX motors in the ATEX manual (NVE42416).

This equipment has been designed to operate outside of any hazardous location. Only install this equipment in zones known to be free of a hazardous atmosphere.

⚠ DANGER

POTENTIAL FOR EXPLOSION

Install and use this equipment in non-hazardous locations only.

Failure to follow these instructions will result in death or serious injury.

ATV680●●●●4X1

What's in This Part

ATV680 Frequency Inverter for 400 V Mains.....	46
General Technical Data	47
Protection Degree	49
Cooling concept	50
Maximum Ambient Temperature	51
Specification	52
Circuit Diagram	81
Mains Connection	82
Motor Connection.....	86
Predefined Customizations	94

ATV680 Frequency Inverter for 400 V Mains

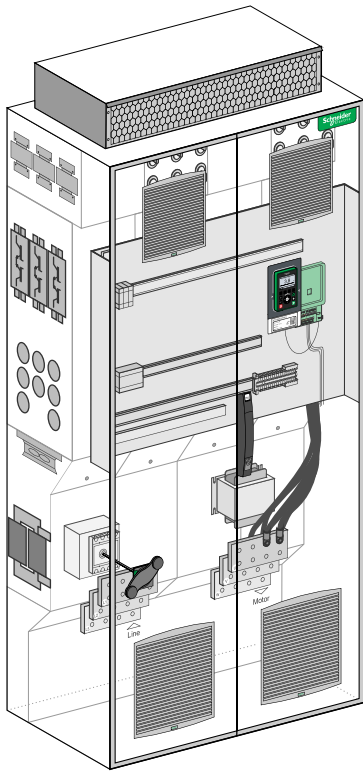

Power components:

- Mains connection terminals
- Main switch
- Semiconductor fuses
- Clean power filter with EMC filter
- Active Front End module(s)
- Inverter module(s)
- dv/dt filter choke(s) (optional at size 1a)
- Terminals for motor connection

Design:

- Floor-standing enclosure
- Integrated control panel
- Protection degree IP23
- Forced cooling
- -10...+50 °C (below 0 °C with additional enclosure heating, above +40 °C with derating)
- Graphical operating panel in the enclosure door

Scope of delivery:

- ATV680 Low Harmonic Drive System
- Multilingual instructions
- Enclosure layout plans consisting of circuit diagram, terminal connection table, list of materials and design drawing
- Transport packaging

Sophisticated service concept with QR code



- Modular design allows easy logistics of spare parts.
- Optimized costs for maintenance due to the dynamic maintenance schedule with integrated monitoring of the individual components.
- Simple exchange of power modules and fans.
- Quick assistance with dynamic QR codes and Customer Care App.



Documentation →  **Asset Life Cycle Documents:** Access to the **Asset Lifecycle Manager** for all product-specific documentation.

General Technical Data

Input	
Rated voltage U_n	for TT, TN-C or TN-S: <ul style="list-style-type: none"> • 3 AC 380 V -10 % ... 415 V +6 % • 3 AC 400 V -10 % ... 415 V +10 % • 3 AC 440 V \pm10 % • 3 AC 480 V \pm10 % Other voltages and mains topologies on request
Rated frequency f_n	50 / 60 Hz \pm 5 %
Total harmonic distortion	\leq 5 % (at nominal load and sinusoidal mains voltage)
Power factor $\cos \Phi$	$>$ 0.99 (at 30...120 % load)
Oversvoltage category	Category III according to EN 50178

Output	
Control method	Asynchronous motor: Variable load torque, constant load torque, energy saving Synchronous motor: PM (permanent magnet) motor
Voltage	3 AC 0...100 % mains voltage
Overload	Normal Duty (ND): 110 % for 60 s per 10 minutes Heavy Duty (HD): 150 % for 60 s per 10 minutes
Pulse frequency	2.5 kHz, adjustable from 2...8 kHz
Frequency	0.1...500 Hz
Short-circuit protection	Short-circuits and ground faults are handled by overcurrent function and switch-off the output.
Speed accuracy	V/f mode: slip frequency VC without feedback: 0.3 x slip frequency

Mechanical strenght	
Mechanical vibrations	According to IEC/EN 60068-2-6 1.5 mm at 3...10 Hz, 0.6 g at 10...200 Hz (3M3 according to IEC/EN 60721-3-3)
Mechanical shock	According to IEC/EN 60068-2-27 4 g for 11 ms (3M2 according to IEC/EN 60721-3-3)

Ambient conditions	
Ambient temperature	-10...+50 °C (below 0 °C with additional enclosure heating, above +40 °C with derating) 3K3 according to IEC/EN 60721-3-3
Storage / Transport temperature	-25...+70 °C
Protection degree	Door closed: IP23 (optionally enclosure design IP54) Door open: IP2x
Environmental class / Humidity	Class 3K3 in accordance with IEC/EN 60721-3-3 / no condensation inside the enclosure, max. 95 % relative humidity
Altitude	Up to 1000 m no derating necessary 1000...2000 m derating of 1 % / 100 m (for all types of mains) 2000...3800 m derating of 1 % / 100 m (only TT/TN, IT) 3800...4800 m derating of 1 % / 100 m (only TT/TN)
Allowed pollution	Pollution degree IP23: 2 according to EN 61800-5-1 Pollution degree IP54 (optional): 3 according to EN 61800-5-1 Chemical / mechanical classification: 3C3 and 3S3 according to EN 60721-3-3
Protection class	Class 1 according to EN 61800-5-1

Functional safety	
Functional safety of the drive	The function "Safe Torque Off" (STO) allows a controlled shut-down and switch-off of the power supply to the motor. It also helps to prevent any unintended start of the motor according to ISO 13849-1, performance level PL e, according to IEC/EN 61508 safety integrity level SIL 3 and IEC/EN 61800-5-2.
Response time	≤ 100 ms at STO (Safe Torque Off)

Standards	
Basic standard	The devices are designed, built and tested on the basis of EN 61800-2, EN 61800-3, EN 61800-5-1 and EN 60204-1.
EMC immunity	According to EN 61800-3, second environment (EN 61000-4-2; EN 61000-4-3; EN 61000-4-4; EN 61000-4-5; EN 61000-4-6)
EMC emission	In accordance with product standard EN 61800-3, second environment, category C3
Insulation	Galvanic insulation of the control circuit in accordance with EN 61800-5-1 PELV (Protective Extra Low Voltage)
Standards	CE, EAC, RCM, ATEX, IEEE 519 (THDi < 5%), RFI filter for second "industrial environment" C3 integrated

Protection Degree

The standard design of the Altivar Process Drive Systems complies with protection degree IP23. It provides optimal cooling of the built-in frequency inverter modules and all power components as well as maximum compactness at the same time.

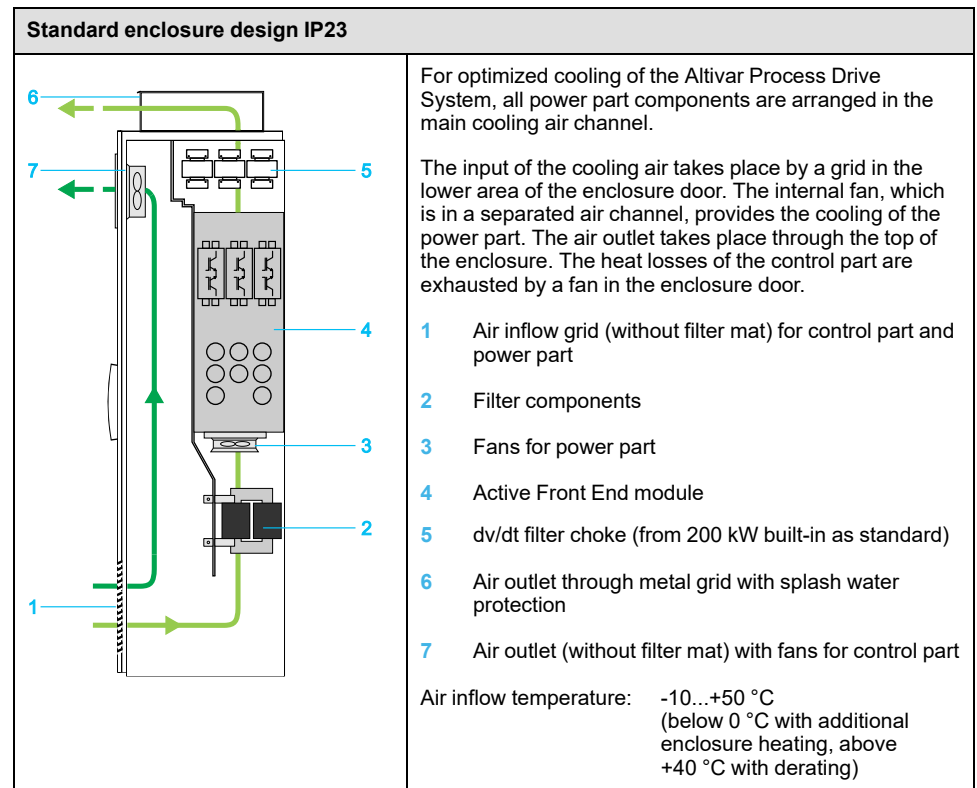

NOTE: For details about the increased protection degree IP54 see chapter Increased Protection Degree IP54, page 123.

Cooling concept

Control/monitoring of fans

The power part fans as well as the fans in the enclosure door are controlled energy optimized depending on the operation. Switching the fans on and off is derived from the start/stop request.

The fans in the power part are equipped with speed monitoring and the fans in the enclosure doors include a temperature monitoring and that helps to protect the Altivar Process Drive Systems. If one of these monitoring units triggers, a warning message is generated.

Furthermore, the operating hours of all fans can be monitored and a warning message can be triggered when the set limit is exceeded.

Overtemperature protection

The temperature of the power part is monitored all the time. In case of overtemperature the pulse frequency or the power is automatically reduced. The temperature of the control part is monitored with a thermostat. When the set temperature is exceeded, a warning message is generated. Only in case of insufficient cooling the drive is necessarily shut down.

Maximum Ambient Temperature

Depending on the chosen pulse frequency, the maximum ambient temperature and the desired output frequency a derating is necessary. This can be determined by means of the following diagrams.

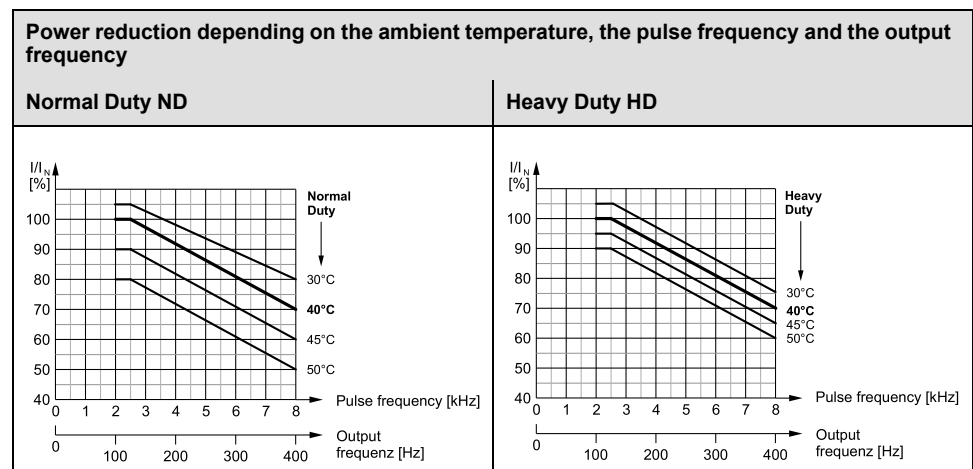

Observe the following guidelines:

- In case of output frequencies higher than 125 Hz the pulse frequency is increased automatically. So the pulse frequency is increased to 4 kHz at 200 Hz output frequency, for example. Consequently, a derating of 8 % at max. 40°C has to be considered.
- Due to the reduction of the output current also the overload capability of the Altivar Process Drive System is reduced.
- At higher pulse frequencies the allowed motor cable length is reduced (see Length of Motor Cables, page 89).
- For full shaft power the motor size should not be more than one power rating bigger than the drive.

NOTE: If the ambient temperature is too high, the pulse frequency is automatically reduced which helps to prevent an overload of the inverter (except in case of operation with sinus-motor-filter).

Specification

What's in This Chapter

Technical Data ATV680C11●4X1	53
Dimensions IP23 for Size 1a	54
Interior View IP23 for Size 1a	54
Technical Data ATV680C13●4X1	55
Dimensions IP23 for Size 1a	56
Interior View IP23 for Size 1a	56
Technical Data ATV680C16●4X1	57
Dimensions IP23 for Size 1a	58
Interior View IP23 for Size 1a	58
Technical Data ATV680C20●4X1	59
Dimensions IP23 for Size 2a	60
Interior View IP23 for Size 2a	60
Technical Data ATV680C25●4X1	61
Dimensions IP23 for Size 2a	62
Interior View IP23 for Size 2a	62
Technical Data ATV680C31●4X1	63
Dimensions IP23 for Size 2a	64
Interior View IP23 for Size 2a	64
Technical Data ATV680C35●4X1	65
Dimensions IP23 for Size 3a	66
Interior View IP23 for Size 3a	66
Technical Data ATV680C40●4X1	67
Dimensions IP23 for Size 3a	68
Interior View IP23 for Size 3a	68
Technical Data ATV680C45●4X1	69
Dimensions IP23 for Size 3a	70
Interior View IP23 for Size 3a	70
Technical Data ATV680C50●4X1	71
Dimensions IP23 for Size 3a	72
Interior View IP23 for Size 3a	72
Technical Data ATV680C56●4X1	73
Dimensions IP23 for Size 4a	74
Interior View IP23 for Size 4a	74
Technical Data ATV680C63●4X1	75
Dimensions IP23 for Size 4a	76
Interior View IP23 for Size 4a	76
Technical Data ATV680C71●4X1	77
Dimensions IP23 for Size 5a	78
Interior View IP23 for Size 5a	78
Technical Data ATV680C80●4X1	79
Dimensions IP23 for Size 5a	80
Interior View IP23 for Size 5a	80

Technical Data ATV680C11•4X1

Type		ATV680C11•4X1	
Nominal data		Normal Duty ND	Heavy Duty HD ⁽¹⁾
Typical motor rating P _n	U _n = 400 V	110 kW	90 kW
	U _n = 440 V	110 kW	90 kW
	U _n = 480 V	132 kW	110 kW
Rated output current I _n		211 A	173 A
Maximum current I _{MAX} for 60 s per 10 minutes		232 A	260 A
Input			
Rated input current I _{in} (at I _{scc} = 22 kA)	U _n = 400 V	175 A	144 A
	U _n = 440 V	159 A	132 A
	U _n = 480 V	175 A	147 A
Rated apparent power S _n	U _n = 400 V	121 kVA	100 kVA
	U _n = 440 V	121 kVA	100 kVA
	U _n = 480 V	145 kVA	123 kVA
Current harmonic THDi ⁽²⁾		< 5 %	
Protection for upstream cables			
Pre-fuse	U _n = 400, 440, 480 V	250 A gG	250 A gG
Circuit breaker I _{therm} / I _{magn}		230 A / 2 kA	200 A / 2 kA
Internal short-circuit protection			
Fuse	U _n = 400, 440, 480 V	250 A aR	
Characteristics			
Efficiency at I _n		0.965	
Heat losses at I _n	Total losses	4220 W	3480 W
	Control part only	560 W	470 W
Weight	Net	400 kg	
	Gross	445 kg	
Ambient conditions			
Air flow	Power part	1160 m ³ /h	
	Control part	140 m ³ /h	
Sound pressure level		70 dB(A)	
Rated short-circuit current I _{scc}	Minimum ⁽³⁾	3 kA	
	Maximum ⁽⁴⁾	50 kA (100 ms)	
Mains and motor connection ⁽⁵⁾			
Typical cable		1x (3x 120 mm ²) or 2x (3x 50 mm ²)	1x (3x 95 mm ²)
Max. Cable cross section ⁽⁶⁾	Cable	2x (3x 240 mm ²) or 3x (3x 120 mm ²) or 4x (3x 95 mm ²)	
	Cable entry ⁽⁷⁾	max. 360 mm	
Terminals per phase		4x M12	
<p>(1) For Heavy Duty HD operation parameter [Dual Rating] <i>drt</i> has to be set to [High rating] <i>HiGH</i> (see programming manual EAV64318).</p> <p>(2) For details see table under chapter Mains Current Harmonics / Mains Voltage Distortion, page 85.</p> <p>(3) Minimum mains short-circuit current</p> <p>(4) Permitted short-circuit current when the specified pre-fuse or circuit breaker is installed</p> <p>(5) You will find further information at chapter Mains Connection, page 82 and at chapter Motor Connection, page 86.</p> <p>(6) Greater connection cross sections are possible with the separate connection enclosure.</p> <p>(7) Maximum possible width of cables connected next to each other in the enclosure</p>			

Dimensions IP23 for Size 1a

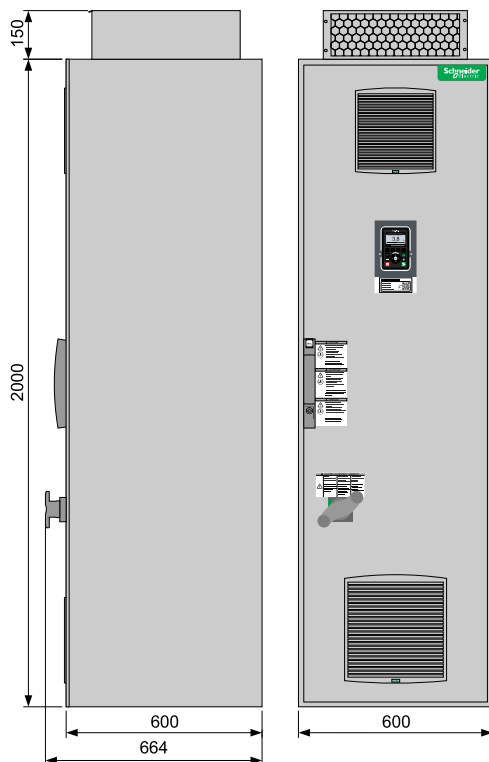

Interior View IP23 for Size 1a

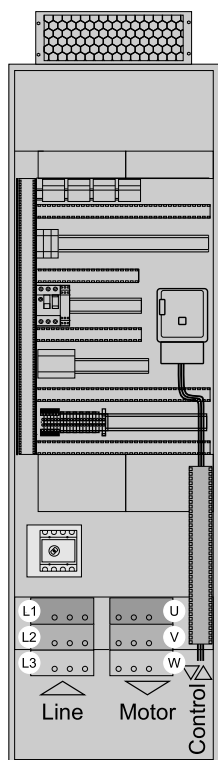

NOTE: Following customizations affect the total dimensions:

- Increased protection degree IP54
- Enclosure plinth for basic device
- Connection enclosure cable from top/ bottom

Technical Data ATV680C13•4X1

Type		ATV680C13•4X1	
Nominal data		Normal Duty ND	Heavy Duty HD ⁽¹⁾
Typical motor rating P _n	U _n = 400 V	132 kW	110 kW
	U _n = 440 V	132 kW	110 kW
	U _n = 480 V	160 kW	132 kW
Rated output current I _n		250 A	211 A
Maximum current I _{MAX} for 60 s per 10 minutes		275 A	317 A
Input			
Rated input current I _{in} (at I _{scc} = 35 kA)	U _n = 400 V	208 A	174 A
	U _n = 440 V	190 A	159 A
	U _n = 480 V	211 A	175 A
Rated apparent power S _n	U _n = 400 V	144 kVA	121 kVA
	U _n = 440 V	145 kVA	121 kVA
	U _n = 480 V	175 kVA	145 kVA
Current harmonic THDi ⁽²⁾		< 5 %	
Protection for upstream cables			
Pre-fuse	U _n = 400, 440, 480 V	300 A gG	300 A gG
Circuit breaker I _{therm} / I _{magn}		280 A / 3 kA	240 A / 3 kA
Internal short-circuit protection			
Fuse	U _n = 400, 440, 480 V	315 A aR	
Characteristics			
Efficiency at I _n		0.965	
Heat losses at I _n	Total losses	5110 W	4200 W
	Control part only	660 W	540 W
Weight	Net	400 kg	
	Gross	445 kg	
Ambient conditions			
Air flow	Power part	1160 m ³ /h	
	Control part	140 m ³ /h	
Sound pressure level		70 dB(A)	
Rated short-circuit current I _{scc}	Minimum ⁽³⁾	3.5 kA	
	Maximum ⁽⁴⁾	50 kA (100 ms)	
Mains and motor connection ⁽⁵⁾			
Typical cable		1x (3x 150 mm ²) or 2x (3x 70 mm ²)	1x (3x 120 mm ²) or 2x (3x 50 mm ²)
Max. Cable cross section ⁽⁶⁾	Cable	2x (3x 240 mm ²) or 3x (3x 120 mm ²) or 4x (3x 95 mm ²)	
	Cable entry ⁽⁷⁾	max. 360 mm	
Terminals per phase		4x M12	
<p>(1) For Heavy Duty HD operation parameter [Dual Rating] <i>drt</i> has to be set to [High rating] <i>HiGH</i> (see programming manual EAV64318).</p> <p>(2) For details see table under chapter Mains Current Harmonics / Mains Voltage Distortion, page 85.</p> <p>(3) Minimum mains short-circuit current</p> <p>(4) Permitted short-circuit current when the specified pre-fuse or circuit breaker is installed</p> <p>(5) You will find further information at chapter Mains Connection, page 82 and at chapter Motor Connection, page 86.</p> <p>(6) Greater connection cross sections are possible with the separate connection enclosure.</p> <p>(7) Maximum possible width of cables connected next to each other in the enclosure</p>			

Dimensions IP23 for Size 1a

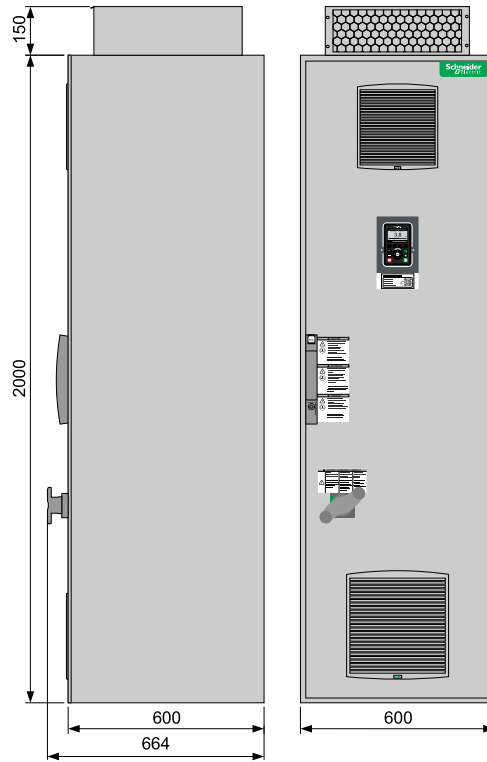

Interior View IP23 for Size 1a

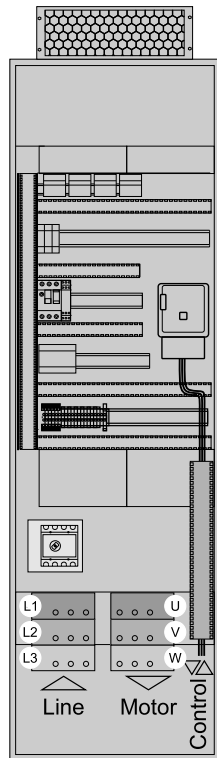

NOTE: Following customizations affect the total dimensions:

- Increased protection degree IP54
- Enclosure plinth for basic device
- Connection enclosure cable from top/ bottom

Technical Data ATV680C16•4X1

Type		ATV680C16•4X1	
Nominal data		Normal Duty ND	Heavy Duty HD ⁽¹⁾
Typical motor rating P_n	$U_n = 400\text{ V}$	160 kW	132 kW
	$U_n = 440\text{ V}$	160 kW	132 kW
	$U_n = 480\text{ V}$	180 kW	160 kW
Rated output current I_n		302 A	250 A
Maximum current I_{MAX} for 60 s per 10 minutes		332 A	375 A
Input			
Rated input current I_{in} (at $I_{sc} = 35\text{ kA}$)	$U_n = 400\text{ V}$	252 A	208 A
	$U_n = 440\text{ V}$	229 A	190 A
	$U_n = 480\text{ V}$	236 A	211 A
Rated apparent power S_n	$U_n = 400\text{ V}$	174 kVA	144 kVA
	$U_n = 440\text{ V}$	174 kVA	145 kVA
	$U_n = 480\text{ V}$	196 kVA	175 kVA
Current harmonic THDi ⁽²⁾		< 5 %	
Protection for upstream cables			
Pre-fuse	$U_n = 400, 440, 480\text{ V}$	315 A gG	300 A gG
Circuit breaker I_{therm} / I_{magn}		315 A / 3 kA	280 A / 3 kA
Internal short-circuit protection			
Fuse	$U_n = 400, 440, 480\text{ V}$	400 A aR	
Characteristics			
Efficiency at I_n		0.965	
Heat losses at I_n	Total losses	6400 W	5100 W
	Control part only	820 W	650 W
Weight	Net	400 kg	
	Gross	445 kg	
Ambient conditions			
Air flow	Power part	1160 m ³ /h	
	Control part	140 m ³ /h	
Sound pressure level		70 dB(A)	
Rated short-circuit current I_{sc}	Minimum ⁽³⁾	4 kA	
	Maximum ⁽⁴⁾	50 kA (100 ms)	
Mains and motor connection ⁽⁵⁾			
Typical cable		1x (3x 185 mm ²) or 2x (3x 95 mm ²)	1x (3x 150 mm ²) or 2x (3x 70 mm ²)
Max. Cable cross section ⁽⁶⁾	Cable	2x (3x 240 mm ²) or 3x (3x 120 mm ²) or 4x (3x 95 mm ²)	
	Cable entry ⁽⁷⁾	max. 360 mm	
Terminals per phase		4x M12	
<p>(1) For Heavy Duty HD operation parameter [Dual Rating] <i>drt</i> has to be set to [High rating] <i>HiGH</i> (see programming manual EAV64318).</p> <p>(2) For details see table under chapter Mains Current Harmonics / Mains Voltage Distortion, page 85.</p> <p>(3) Minimum mains short-circuit current</p> <p>(4) Permitted short-circuit current when the specified pre-fuse or circuit breaker is installed</p> <p>(5) You will find further information at chapter Mains Connection, page 82 and at chapter Motor Connection, page 86.</p> <p>(6) Greater connection cross sections are possible with the separate connection enclosure.</p> <p>(7) Maximum possible width of cables connected next to each other in the enclosure</p>			

Dimensions IP23 for Size 1a

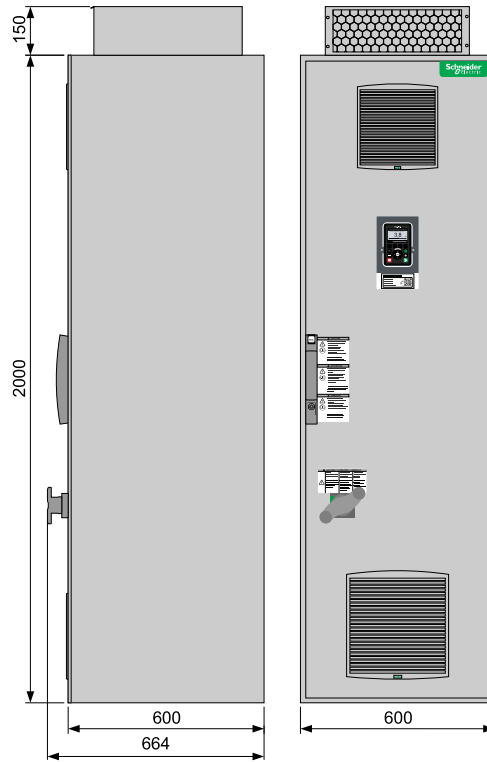

Interior View IP23 for Size 1a

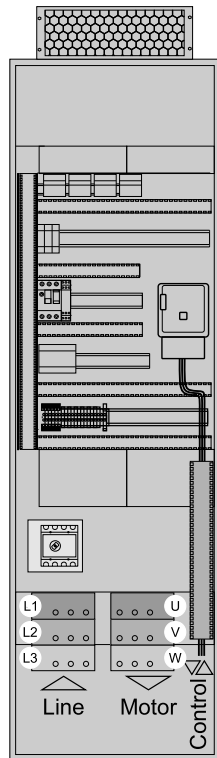

NOTE: Following customizations affect the total dimensions:

- Increased protection degree IP54
- Enclosure plinth for basic device
- Connection enclosure cable from top/ bottom

Technical Data ATV680C20•4X1

Type		ATV680C20•4X1	
Nominal data		Normal Duty ND	Heavy Duty HD ⁽¹⁾
Typical motor rating P_n	$U_n = 400\text{ V}$	200 kW	160 kW
	$U_n = 440\text{ V}$	200 kW	160 kW
	$U_n = 480\text{ V}$	220 kW	180 kW
Rated output current I_n		370 A	302 A
Maximum current I_{MAX} for 60 s per 10 minutes		407 A	453 A
Input			
Rated input current I_{in} (at $I_{sc} = 35\text{ kA}$)	$U_n = 400\text{ V}$	313 A	252 A
	$U_n = 440\text{ V}$	285 A	229 A
	$U_n = 480\text{ V}$	287 A	236 A
Rated apparent power S_n	$U_n = 400\text{ V}$	217 kVA	174 kVA
	$U_n = 440\text{ V}$	217 kVA	174 kVA
	$U_n = 480\text{ V}$	239 kVA	196 kVA
Current harmonic THDi ⁽²⁾		< 5 %	
Protection for upstream cables			
Pre-fuse	$U_n = 400, 440, 480\text{ V}$	400 A gG	355 A gG
Circuit breaker I_{therm} / I_{magn}		400 A / 4 kA	330 A / 4 kA
Internal short-circuit protection			
Fuse	$U_n = 400, 440, 480\text{ V}$	2x 250 A aR	
Characteristics			
Efficiency at I_n		0.965	
Heat losses at I_n	Total losses	7890 W	6450 W
	Control part only	940 W	770 W
Weight	Net	700 kg	
	Gross	755 kg	
Ambient conditions			
Air flow	Power part	2320 m ³ /h	
	Control part	280 m ³ /h	
Sound pressure level		73 dB(A)	
Rated short-circuit current I_{sc}	Minimum ⁽³⁾	5.5 kA	
	Maximum ⁽⁴⁾	50 kA (100 ms)	
Mains and motor connection ⁽⁵⁾			
Typical cable		2x (3x 120 mm ²) or 3x (3x 70 mm ²)	1x (3x 185 mm ²) or 2x (3x 95 mm ²)
Max. Cable cross section ⁽⁶⁾	Cable	2x (3x 240 mm ²) or 4x (3x 185 mm ²)	
	Cable entry ⁽⁷⁾	max. 760 mm	
Terminals per phase		4x M12	
<p>(1) For Heavy Duty HD operation parameter [Dual Rating] <i>drt</i> has to be set to [High rating] <i>HiGH</i> (see programming manual EAV64318).</p> <p>(2) For details see table under chapter Mains Current Harmonics / Mains Voltage Distortion, page 85.</p> <p>(3) Minimum mains short-circuit current</p> <p>(4) Permitted short-circuit current when the specified pre-fuse or circuit breaker is installed</p> <p>(5) You will find further information at chapter Mains Connection, page 82 and at chapter Motor Connection, page 86.</p> <p>(6) Greater connection cross sections are possible with the separate connection enclosure.</p> <p>(7) Maximum possible width of cables connected next to each other in the enclosure</p>			

Dimensions IP23 for Size 2a

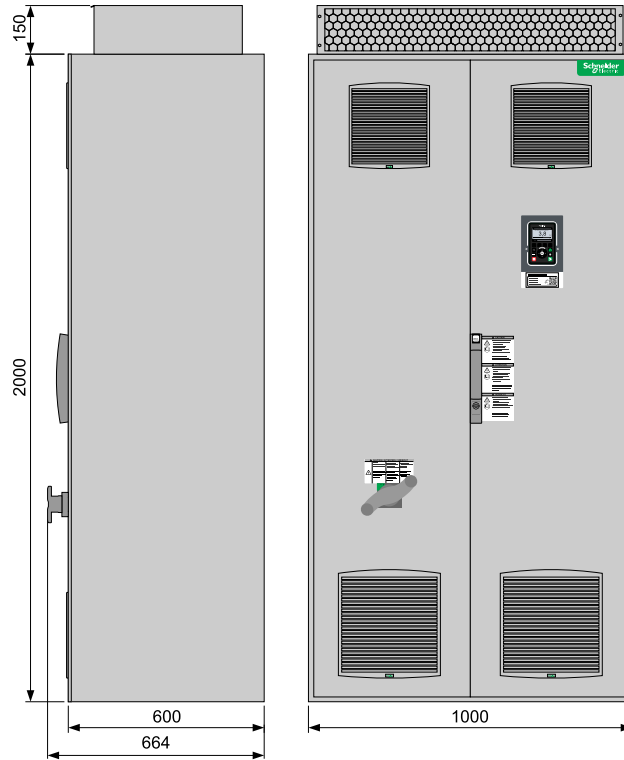

Interior View IP23 for Size 2a

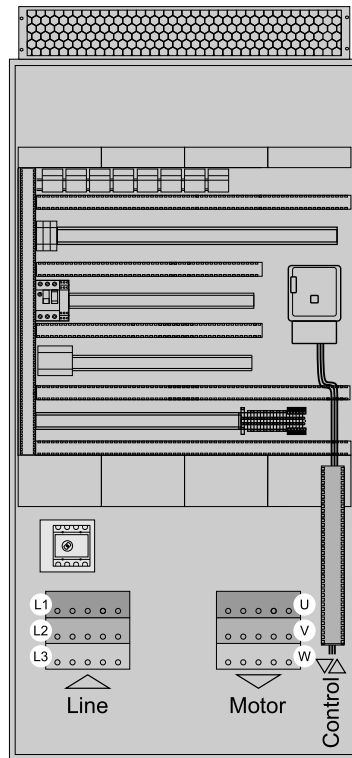

NOTE: Following customizations affect the total dimensions:

- Increased protection degree IP54
- Enclosure plinth for basic device
- Connection enclosure cable from top/ bottom

Technical Data ATV680C25•4X1

Type		ATV680C25•4X1	
Nominal data		Normal Duty ND	Heavy Duty HD ⁽¹⁾
Typical motor rating P_n	$U_n = 400\text{ V}$	250 kW	200 kW
	$U_n = 440\text{ V}$	250 kW	200 kW
	$U_n = 480\text{ V}$	280 kW	220 kW
Rated output current I_n		477 A	370 A
Maximum current I_{MAX} for 60 s per 10 minutes		525 A	555 A
Input			
Rated input current I_{in} (at $I_{sc} = 50\text{ kA}$)	$U_n = 400\text{ V}$	389 A	313 A
	$U_n = 440\text{ V}$	354 A	285 A
	$U_n = 480\text{ V}$	363 A	287 A
Rated apparent power S_n	$U_n = 400\text{ V}$	270 kVA	217 kVA
	$U_n = 440\text{ V}$	270 kVA	217 kVA
	$U_n = 480\text{ V}$	302 kVA	239 kVA
Current harmonic THDi ⁽²⁾		< 5 %	
Protection for upstream cables			
Pre-fuse	$U_n = 400, 440, 480\text{ V}$	500 A gG	400 A gG
Circuit breaker I_{therm} / I_{magn}		500 A / 5 kA	400 A / 5 kA
Internal short-circuit protection			
Fuse	$U_n = 400, 440, 480\text{ V}$	2x 315 A aR	
Characteristics			
Efficiency at I_n		0.965	
Heat losses at I_n	Total losses	9910 W	7870 W
	Control part only	1160 W	920 W
Weight	Net	700 kg	
	Gross	755 kg	
Ambient conditions			
Air flow	Power part	2320 m ³ /h	
	Control part	280 m ³ /h	
Sound pressure level		73 dB(A)	
Rated short-circuit current I_{sc}	Minimum ⁽³⁾	7 kA	
	Maximum ⁽⁴⁾	50 kA (100 ms)	
Mains and motor connection ⁽⁵⁾			
Typical cable		2x (3x 150 mm ²) or 3x (3x 95 mm ²)	2x (3x 120 mm ²) or 3x (3x 70 mm ²)
Max. Cable cross section ⁽⁶⁾	Cable	2x (3x 240 mm ²) or 4x (3x 185 mm ²)	
	Cable entry ⁽⁷⁾	max. 760 mm	
Terminals per phase		4x M12	
<p>(1) For Heavy Duty HD operation parameter [Dual Rating] <i>drt</i> has to be set to [High rating] <i>HiGH</i> (see programming manual EAV64318).</p> <p>(2) For details see table under chapter Mains Current Harmonics / Mains Voltage Distortion, page 85.</p> <p>(3) Minimum mains short-circuit current</p> <p>(4) Permitted short-circuit current when the specified pre-fuse or circuit breaker is installed</p> <p>(5) You will find further information at chapter Mains Connection, page 82 and at chapter Motor Connection, page 86.</p> <p>(6) Greater connection cross sections are possible with the separate connection enclosure.</p> <p>(7) Maximum possible width of cables connected next to each other in the enclosure</p>			

Dimensions IP23 for Size 2a

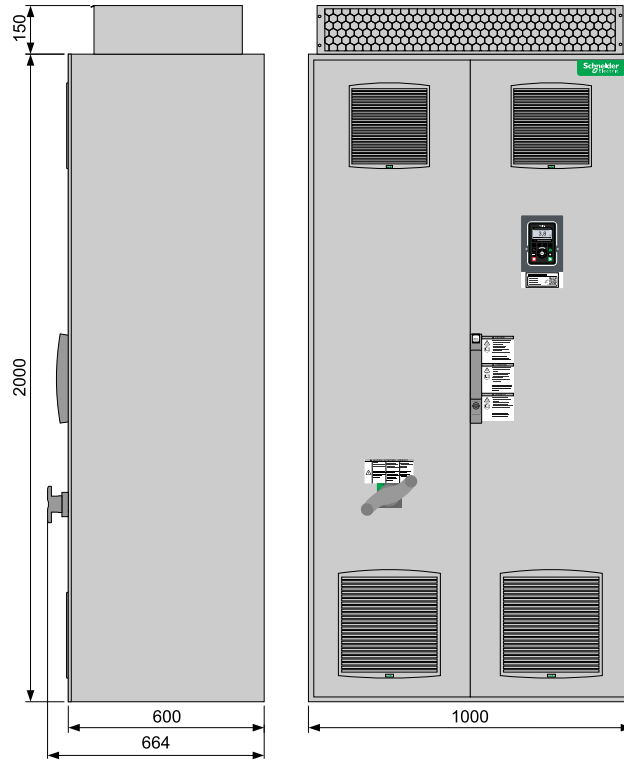

Interior View IP23 for Size 2a

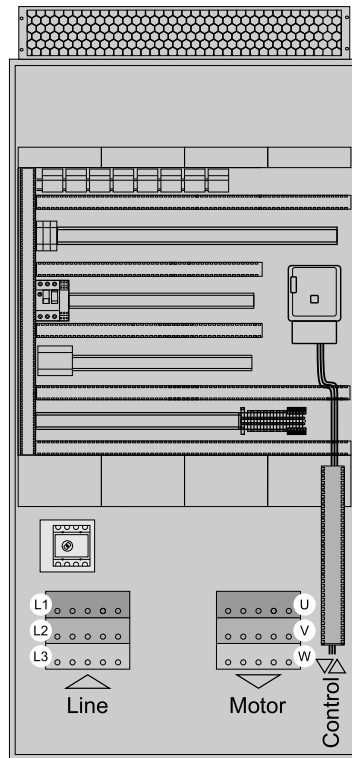

NOTE: Following customizations affect the total dimensions:

- Increased protection degree IP54
- Enclosure plinth for basic device
- Connection enclosure cable from top/ bottom

Technical Data ATV680C31•4X1

Type		ATV680C31•4X1	
Nominal data		Normal Duty ND	Heavy Duty HD ⁽¹⁾
Typical motor rating P _n	U _n = 400 V	315 kW	250 kW
	U _n = 440 V	315 kW	250 kW
	U _n = 480 V	355 kW	280 kW
Rated output current I _n		590 A	477 A
Maximum current I _{MAX} for 60 s per 10 minutes		649 A	716 A
Input			
Rated input current I _{in} (at I _{scc} = 50 kA)	U _n = 400 V	491 A	389 A
	U _n = 440 V	446 A	354 A
	U _n = 480 V	461 A	363 A
Rated apparent power S _n	U _n = 400 V	340 kVA	270 kVA
	U _n = 440 V	340 kVA	270 kVA
	U _n = 480 V	383 kVA	302 kVA
Current harmonic THDi ⁽²⁾		< 5 %	
Protection for upstream cables			
Pre-fuse	U _n = 400, 440, 480 V	630 A gG	500 A gG
Circuit breaker I _{therm} / I _{magn}		630 A / 6 kA	500 A / 6 kA
Internal short-circuit protection			
Fuse	U _n = 400, 440, 480 V	2x 400 A aR	
Characteristics			
Efficiency at I _n		0.965	
Heat losses at I _n	Total losses	13060 W	9890 W
	Control part only	1560 W	1140 W
Weight	Net	700 kg	
	Gross	755 kg	
Ambient conditions			
Air flow	Power part	2320 m ³ /h	
	Control part	280 m ³ /h	
Sound pressure level		73 dB(A)	
Rated short-circuit current I _{scc}	Minimum ⁽³⁾	8 kA	
	Maximum ⁽⁴⁾	50 kA (100 ms)	
Mains and motor connection ⁽⁵⁾			
Typical cable		2x (3x 185 mm ²) or 3x (3x 120 mm ²)	2x (3x 150 mm ²) or 3x (3x 120 mm ²)
Max. Cable cross section ⁽⁶⁾	Cable	2x (3x 240 mm ²) or 4x (3x 185 mm ²)	
	Cable entry ⁽⁷⁾	max. 760 mm	
Terminals per phase		4x M12	
<p>(1) For Heavy Duty HD operation parameter [Dual Rating] <i>drt</i> has to be set to [High rating] <i>HiGH</i> (see programming manual EAV64318).</p> <p>(2) For details see table under chapter Mains Current Harmonics / Mains Voltage Distortion, page 85.</p> <p>(3) Minimum mains short-circuit current</p> <p>(4) Permitted short-circuit current when the specified pre-fuse or circuit breaker is installed</p> <p>(5) You will find further information at chapter Mains Connection, page 82 and at chapter Motor Connection, page 86.</p> <p>(6) Greater connection cross sections are possible with the separate connection enclosure.</p> <p>(7) Maximum possible width of cables connected next to each other in the enclosure</p>			

Dimensions IP23 for Size 2a

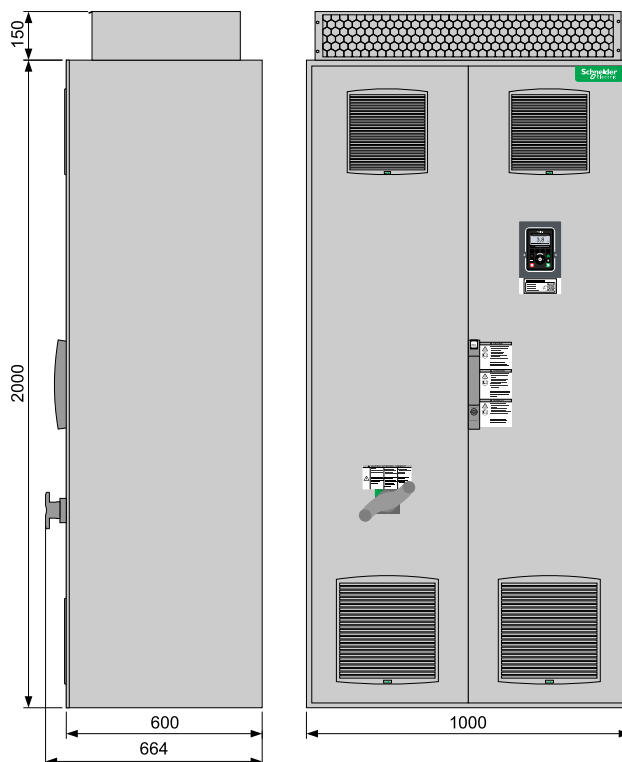

Interior View IP23 for Size 2a

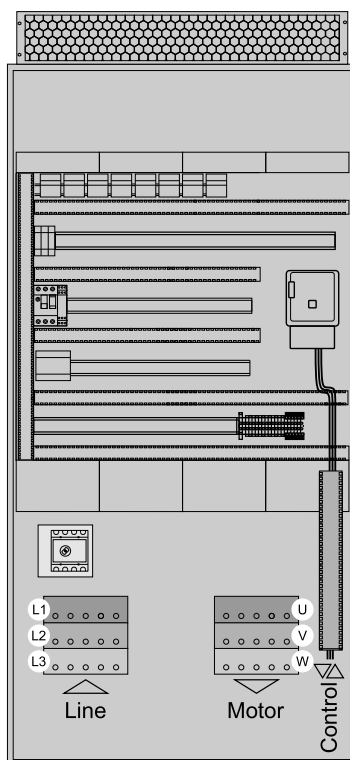

NOTE: Following customizations affect the total dimensions:

- Increased protection degree IP54
- Enclosure plinth for basic device
- Connection enclosure cable from top/ bottom

Technical Data ATV680C35•4X1

Type		ATV680C35•4X1	
Nominal data		Normal Duty ND	Heavy Duty HD ⁽¹⁾
Typical motor rating P _n	U _n = 400 V	355 kW	280 kW
	U _n = 440 V	355 kW	280 kW
	U _n = 480 V	400 kW	315 kW
Rated output current I _n		660 A	520 A
Maximum current I _{MAX} for 60 s per 10 minutes		726 A	780 A
Input			
Rated input current I _{in} (at I _{scc} = 50 kA)	U _n = 400 V	553 A	436 A
	U _n = 440 V	503 A	396 A
	U _n = 480 V	519 A	409 A
Rated apparent power S _n	U _n = 400 V	383 kVA	302 kVA
	U _n = 440 V	383 kVA	302 kVA
	U _n = 480 V	432 kVA	340 kVA
Current harmonic THDi ⁽²⁾		< 5 %	
Protection for upstream cables			
Pre-fuse	U _n = 400, 440, 480 V	800 A gG	630 A gG
Circuit breaker I _{therm} / I _{magn}		700 A / 7 kA	580 A / 7 kA
Internal short-circuit protection			
Fuse	U _n = 400, 440, 480 V	3x 315 A aR	
Characteristics			
Efficiency at I _n		0.965	
Heat losses at I _n	Total losses	13970 W	10990 W
	Control part only	1570 W	1240 W
Weight	Net	1150 kg	
	Gross	1220 kg	
Ambient conditions			
Air flow	Power part	3480 m ³ /h	
	Control part	420 m ³ /h	
Sound pressure level		75 dB(A)	
Rated short-circuit current I _{scc}	Minimum ⁽³⁾	11 kA	
	Maximum ⁽⁴⁾	50 kA (100 ms)	
Mains and motor connection ⁽⁵⁾			
Typical cable		3x (3x 150 mm ²) or 4x (3x 95 mm ²)	2x (3x 185 mm ²) or 3x (3x 120 mm ²)
Max. Cable cross section ⁽⁶⁾	Cable	3x (3x 240 mm ²) or 4x (3x 185 mm ²) or 6x (3x 120 mm ²)	
	Cable entry mains ⁽⁷⁾	max. 360 mm	
	Cable entry motor ⁽⁷⁾	max. 760 mm	
Terminals per phase		6x M12	
<p>(1) For Heavy Duty HD operation parameter [Dual Rating] <i>drt</i> has to be set to [High rating] <i>HIGH</i> (see programming manual EAV64318).</p> <p>(2) For details see table under chapter Mains Current Harmonics / Mains Voltage Distortion, page 85.</p> <p>(3) Minimum mains short-circuit current</p> <p>(4) Permitted short-circuit current when the specified pre-fuse or circuit breaker is installed</p> <p>(5) You will find further information at chapter Mains Connection, page 82 and at chapter Motor Connection, page 86.</p> <p>(6) Greater connection cross sections are possible with the separate connection enclosure.</p> <p>(7) Maximum possible width of cables connected next to each other in the enclosure</p>			

Dimensions IP23 for Size 3a

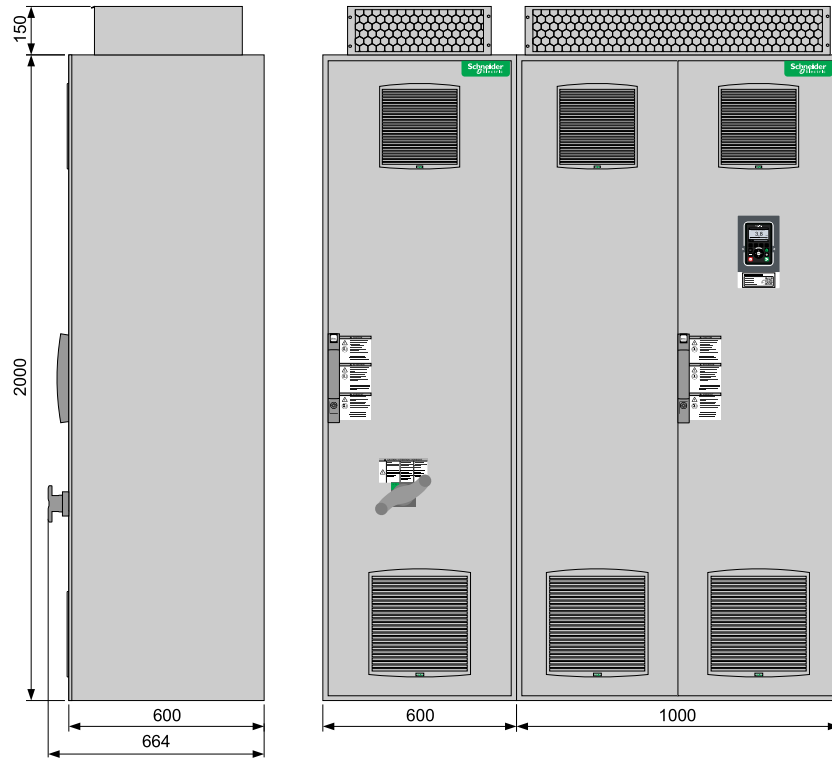

Interior View IP23 for Size 3a

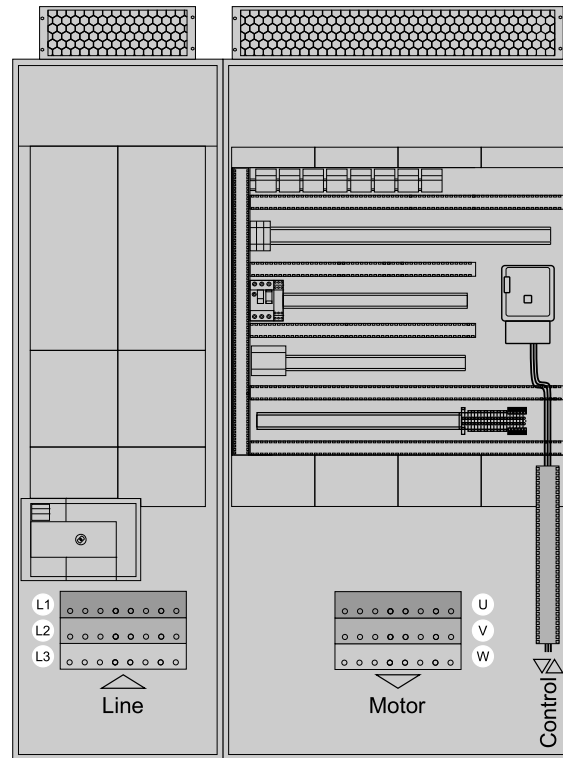

NOTE: Following customizations affect the total dimensions:

- Increased protection degree IP54
- Enclosure plinth for basic device
- Connection enclosure cable from top/ bottom

Technical Data ATV680C40•4X1

Type		ATV680C40•4X1	
Nominal data		Normal Duty ND	Heavy Duty HD ⁽¹⁾
Typical motor rating P _n	U _n = 400 V	400 kW	315 kW
	U _n = 440 V	400 kW	315 kW
	U _n = 480 V	450 kW	355 kW
Rated output current I _n		730 A	590 A
Maximum current I _{MAX} for 60 s per 10 minutes		803 A	885 A
Input			
Rated input current I _{in} (at I _{sc} = 50 kA)	U _n = 400 V	620 A	491 A
	U _n = 440 V	563 A	446 A
	U _n = 480 V	581 A	461 A
Rated apparent power S _n	U _n = 400 V	429 kVA	340 kVA
	U _n = 440 V	429 kVA	340 kVA
	U _n = 480 V	483 kVA	383 kVA
Current harmonic THDi ⁽²⁾		< 5 %	
Protection for upstream cables			
Pre-fuse	U _n = 400, 440, 480 V	800 A gG	630 A gG
Circuit breaker I _{therm} / I _{magn}		780 A / 8 kA	630 A / 8 kA
Internal short-circuit protection			
Fuse	U _n = 400, 440, 480 V	3x 315 A aR	
Characteristics			
Efficiency at I _n		0.965	
Heat losses at I _n	Total losses	15850 W	12300 W
	Control part only	1800 W	1400 W
Weight	Net	1150 kg	
	Gross	1220 kg	
Ambient conditions			
Air flow	Power part	3480 m ³ /h	
	Control part	420 m ³ /h	
Sound pressure level		75 dB(A)	
Rated short-circuit current I _{sc}	Minimum ⁽³⁾	11 kA	
	Maximum ⁽⁴⁾	50 kA (100 ms)	
Mains and motor connection ⁽⁵⁾			
Typical cable		3x (3x 185 mm ²) or 4x (3x 120 mm ²)	3x (3x 120 mm ²) or 4x (3x 95 mm ²)
Max. Cable cross section ⁽⁶⁾	Cable	3x (3x 240 mm ²) or 4x (3x 185 mm ²) or 6x (3x 120 mm ²)	
	Cable entry mains ⁽⁷⁾	max. 360 mm	
	Cable entry motor ⁽⁷⁾	max. 760 mm	
Terminals per phase		6x M12	
<p>(1) For Heavy Duty HD operation parameter [Dual Rating] <i>drt</i> has to be set to [High rating] <i>HIGH</i> (see programming manual EAV64318).</p> <p>(2) For details see table under chapter Mains Current Harmonics / Mains Voltage Distortion, page 85.</p> <p>(3) Minimum mains short-circuit current</p> <p>(4) Permitted short-circuit current when the specified pre-fuse or circuit breaker is installed</p> <p>(5) You will find further information at chapter Mains Connection, page 82 and at chapter Motor Connection, page 86.</p> <p>(6) Greater connection cross sections are possible with the separate connection enclosure.</p> <p>(7) Maximum possible width of cables connected next to each other in the enclosure</p>			

Dimensions IP23 for Size 3a

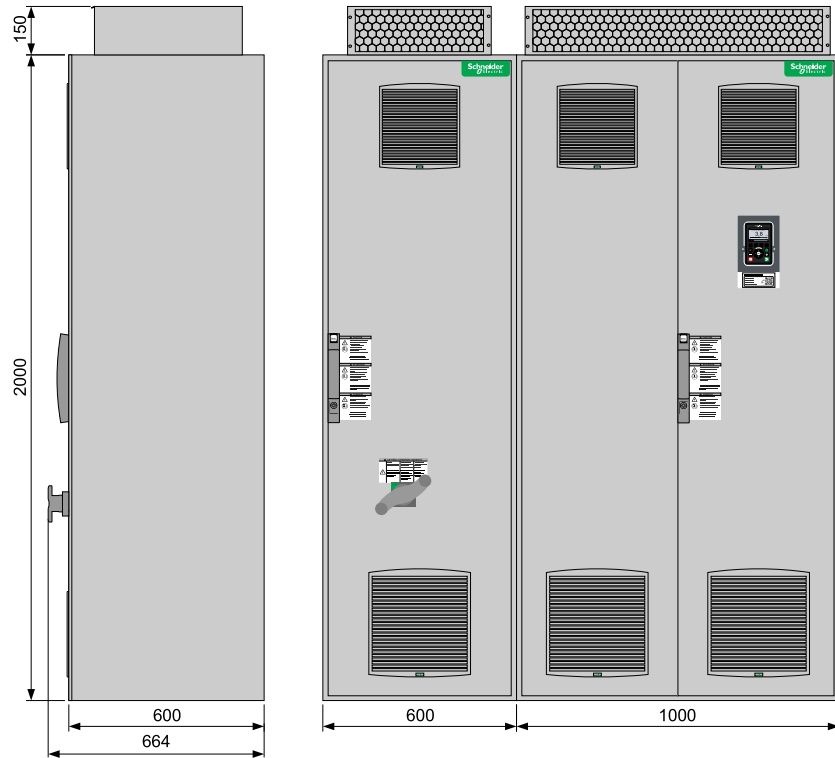

Interior View IP23 for Size 3a

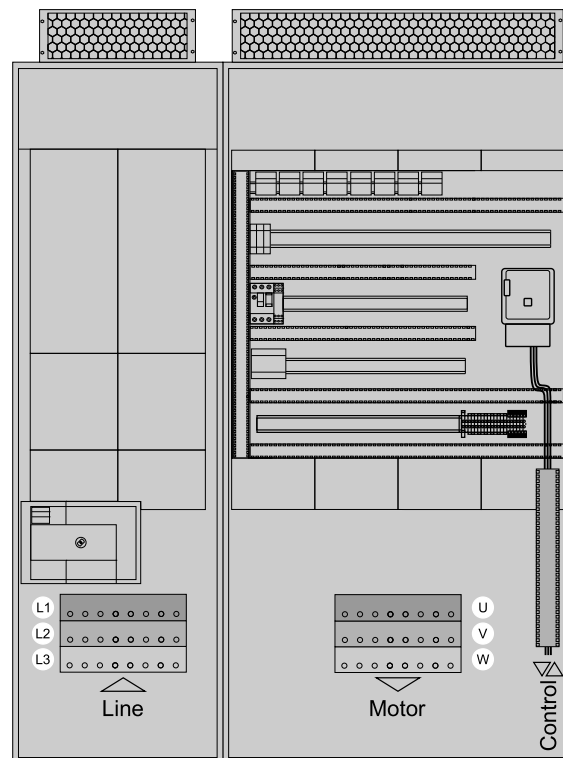

NOTE: Following customizations affect the total dimensions:

- Increased protection degree IP54
- Enclosure plinth for basic device
- Connection enclosure cable from top/ bottom

Technical Data ATV680C45•4X1

Type		ATV680C45•4X1	
Nominal data		Normal Duty ND	Heavy Duty HD ⁽¹⁾
Typical motor rating P_n	$U_n = 400\text{ V}$	450 kW	355 kW
	$U_n = 440\text{ V}$	450 kW	355 kW
	$U_n = 480\text{ V}$	500 kW	400 kW
Rated output current I_n		830 A	660 A
Maximum current I_{MAX} for 60 s per 10 minutes		913 A	990 A
Input			
Rated input current I_{in} (at $I_{sc} = 50\text{ kA}$)	$U_n = 400\text{ V}$	697 A	553 A
	$U_n = 440\text{ V}$	634 A	503 A
	$U_n = 480\text{ V}$	646 A	519 A
Rated apparent power S_n	$U_n = 400\text{ V}$	483 kVA	383 kVA
	$U_n = 440\text{ V}$	483 kVA	383 kVA
	$U_n = 480\text{ V}$	537 kVA	432 kVA
Current harmonic THDi ⁽²⁾		< 5 %	
Protection for upstream cables			
Pre-fuse	$U_n = 400, 440, 480\text{ V}$	1000 A gG	800 A gG
Circuit breaker I_{therm} / I_{magn}		900 A / 9 kA	720 A / 9 kA
Internal short-circuit protection			
Fuse	$U_n = 400, 440, 480\text{ V}$	3x 400 A aR	
Characteristics			
Efficiency at I_n		0.965	
Heat losses at I_n	Total losses	18210 W	13960 W
	Control part only	2060 W	1560 W
Weight	Net	1150 kg	
	Gross	1220 kg	
Ambient conditions			
Air flow	Power part	3480 m ³ /h	
	Control part	420 m ³ /h	
Sound pressure level		75 dB(A)	
Rated short-circuit current I_{sc}	Minimum ⁽³⁾	13 kA	
	Maximum ⁽⁴⁾	50 kA (100 ms)	
Mains and motor connection ⁽⁵⁾			
Typical cable		4x (3x 150 mm ²) or 5x (3x 120 mm ²)	3x (3x 150 mm ²) or 4x (3x 95 mm ²)
Max. Cable cross section ⁽⁶⁾	Cable	3x (3x 240 mm ²) or 4x (3x 185 mm ²) or 6x (3x 120 mm ²)	
	Cable entry mains ⁽⁷⁾	max. 360 mm	
	Cable entry motor ⁽⁷⁾	max. 760 mm	
Terminals per phase		6x M12	
<p>(1) For Heavy Duty HD operation parameter [Dual Rating] <i>drt</i> has to be set to [High rating] <i>HIGH</i> (see programming manual EAV64318).</p> <p>(2) For details see table under chapter Mains Current Harmonics / Mains Voltage Distortion, page 85.</p> <p>(3) Minimum mains short-circuit current</p> <p>(4) Permitted short-circuit current when the specified pre-fuse or circuit breaker is installed</p> <p>(5) You will find further information at chapter Mains Connection, page 82 and at chapter Motor Connection, page 86.</p> <p>(6) Greater connection cross sections are possible with the separate connection enclosure.</p> <p>(7) Maximum possible width of cables connected next to each other in the enclosure</p>			

Dimensions IP23 for Size 3a

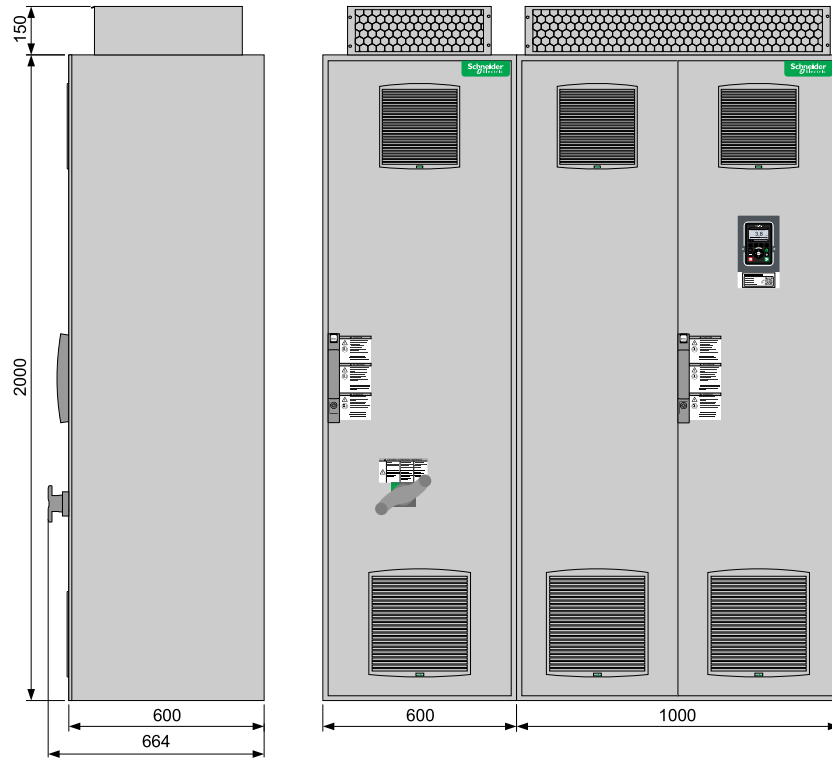

Interior View IP23 for Size 3a

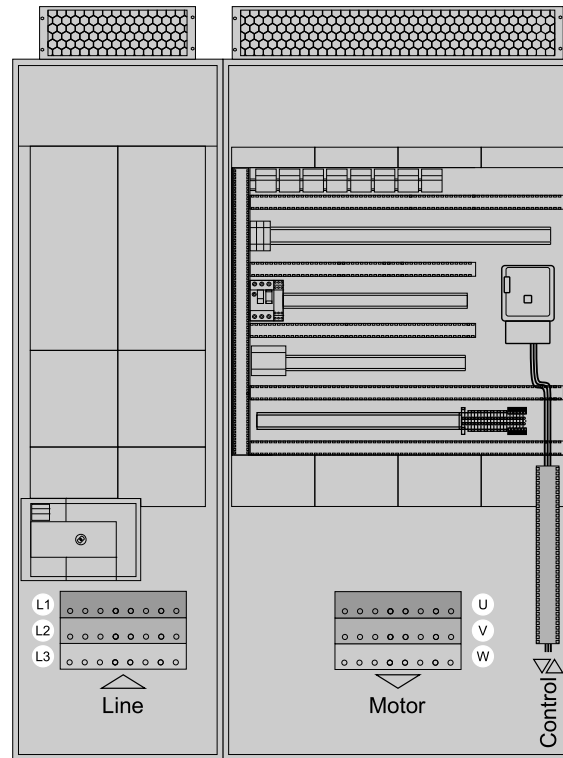

NOTE: Following customizations affect the total dimensions:

- Increased protection degree IP54
- Enclosure plinth for basic device
- Connection enclosure cable from top/ bottom

Technical Data ATV680C50•4X1

Type		ATV680C50•4X1	
Nominal data		Normal Duty ND	Heavy Duty HD ⁽¹⁾
Typical motor rating P _n	U _n = 400 V	500 kW	400 kW
	U _n = 440 V	500 kW	400 kW
	U _n = 480 V	560 kW	450 kW
Rated output current I _n		900 A	730 A
Maximum current I _{MAX} for 60 s per 10 minutes		990 A	1095 A
Input			
Rated input current I _{in} (at I _{scc} = 50 kA)	U _n = 400 V	775 A	620 A
	U _n = 440 V	704 A	563 A
	U _n = 480 V	723 A	581 A
Rated apparent power S _n	U _n = 400 V	537 kVA	429 kVA
	U _n = 440 V	537 kVA	429 kVA
	U _n = 480 V	601 kVA	483 kVA
Current harmonic THDi ⁽²⁾		< 5 %	
Protection for upstream cables			
Pre-fuse	U _n = 400, 440, 480 V	1000 A gG	800 A gG
Circuit breaker I _{therm} / I _{magn}		1000 A / 10 kA	800 A / 10 kA
Internal short-circuit protection			
Fuse	U _n = 400, 440, 480 V	3x 400 A aR	
Characteristics			
Efficiency at I _n		0.965	
Heat losses at I _n	Total losses	20800 W	15830 W
	Control part only	2400 W	1780 W
Weight	Net	1150 kg	
	Gross	1220 kg	
Ambient conditions			
Air flow	Power part	3480 m ³ /h	
	Control part	420 m ³ /h	
Sound pressure level		75 dB(A)	
Rated short-circuit current I _{scc}	Minimum ⁽³⁾	13 kA	
	Maximum ⁽⁴⁾	50 kA (100 ms)	
Mains and motor connection ⁽⁵⁾			
Typical cable		4x (3x 185 mm ²) or 5x (3x 120 mm ²)	3x (3x 185 mm ²) or 4x (3x 120 mm ²)
Max. Cable cross section ⁽⁶⁾	Cable	3x (3x 240 mm ²) or 4x (3x 185 mm ²) or 6x (3x 120 mm ²)	
	Cable entry mains ⁽⁷⁾	max. 360 mm	
	Cable entry motor ⁽⁷⁾	max. 760 mm	
Terminals per phase		6x M12	
<p>(1) For Heavy Duty HD operation parameter [Dual Rating] <i>drt</i> has to be set to [High rating] <i>HIGH</i> (see programming manual EAV64318).</p> <p>(2) For details see table under chapter Mains Current Harmonics / Mains Voltage Distortion, page 85.</p> <p>(3) Minimum mains short-circuit current</p> <p>(4) Permitted short-circuit current when the specified pre-fuse or circuit breaker is installed</p> <p>(5) You will find further information at chapter Mains Connection, page 82 and at chapter Motor Connection, page 86.</p> <p>(6) Greater connection cross sections are possible with the separate connection enclosure.</p> <p>(7) Maximum possible width of cables connected next to each other in the enclosure</p>			

Dimensions IP23 for Size 3a

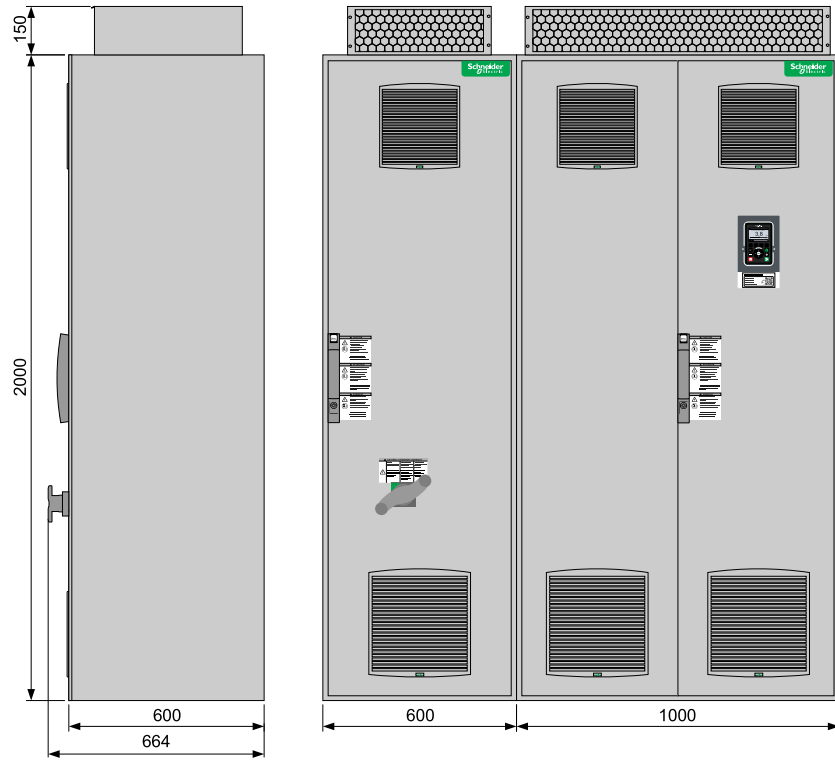

Interior View IP23 for Size 3a

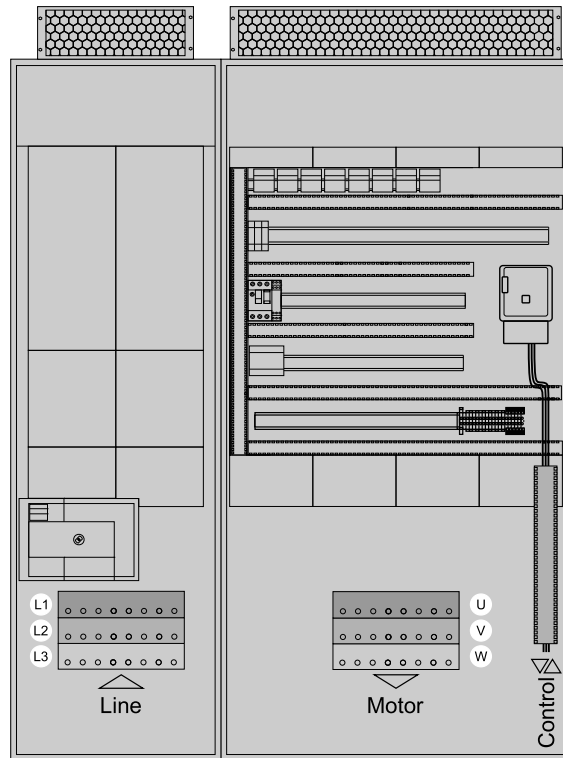

NOTE: Following customizations affect the total dimensions:

- Increased protection degree IP54
- Enclosure plinth for basic device
- Connection enclosure cable from top/ bottom

Technical Data ATV680C56•4X1

Type		ATV680C56•4X1	
Nominal data		Normal Duty ND	Heavy Duty HD ⁽¹⁾
Typical motor rating P_n	$U_n = 400\text{ V}$	560 kW	450 kW
	$U_n = 440\text{ V}$	560 kW	450 kW
	$U_n = 480\text{ V}$	630 kW	500 kW
Rated output current I_n		1020 A	830 A
Maximum current I_{MAX} for 60 s per 10 minutes		1122 A	1245 A
Input			
Rated input current I_{in} (at $I_{sc} = 50\text{ kA}$)	$U_n = 400\text{ V}$	868 A	697 A
	$U_n = 440\text{ V}$	789 A	634 A
	$U_n = 480\text{ V}$	813 A	646 A
Rated apparent power S_n	$U_n = 400\text{ V}$	601 kVA	483 kVA
	$U_n = 440\text{ V}$	601 kVA	483 kVA
	$U_n = 480\text{ V}$	676 kVA	537 kVA
Current harmonic THDi ⁽²⁾		< 5 %	
Protection for upstream cables			
Pre-fuse	$U_n = 400, 440, 480\text{ V}$	1250 A gG	1000 A gG
Circuit breaker I_{therm} / I_{magn}		1100 A / 11 kA	900 A / 11 kA
Internal short-circuit protection			
Fuse	$U_n = 400, 440, 480\text{ V}$	4x 400 A aR	
Characteristics			
Efficiency at I_n		0.965	
Heat losses at I_n	Total losses	22300 W	17480 W
	Control part only	2500 W	1930 W
Weight	Net	1450 kg	
	Gross	1530 kg	
Ambient conditions			
Air flow	Power part	4640 m ³ /h	
	Control part	560 m ³ /h	
Sound pressure level		77 dB(A)	
Rated short-circuit current I_{sc}	Minimum ⁽³⁾	15 kA	
	Maximum ⁽⁴⁾	50 kA (100 ms)	
Mains and motor connection ⁽⁵⁾			
Typical cable		4x (3x 185 mm ²) or 5x (3x 150 mm ²)	4x (3x 150 mm ²) or 5x (3x 120 mm ²)
Max. Cable cross section ⁽⁶⁾	Cable	5x (3x 240 mm ²) or 6x (3x 185 mm ²)	
	Cable entry mains ⁽⁷⁾	max. 760 mm	
	Cable entry motor ⁽⁷⁾	max. 760 mm	
Terminals per phase		8x M12	
<p>(1) For Heavy Duty HD operation parameter [Dual Rating] <i>drt</i> has to be set to [High rating] <i>HiGH</i> (see programming manual EAV64318).</p> <p>(2) For details see table under chapter Mains Current Harmonics / Mains Voltage Distortion, page 85.</p> <p>(3) Minimum mains short-circuit current</p> <p>(4) Permitted short-circuit current when the specified pre-fuse or circuit breaker is installed</p> <p>(5) You will find further information at chapter Mains Connection, page 82 and at chapter Motor Connection, page 86.</p> <p>(6) Greater connection cross sections are possible with the separate connection enclosure.</p> <p>(7) Maximum possible width of cables connected next to each other in the enclosure</p>			

Dimensions IP23 for Size 4a

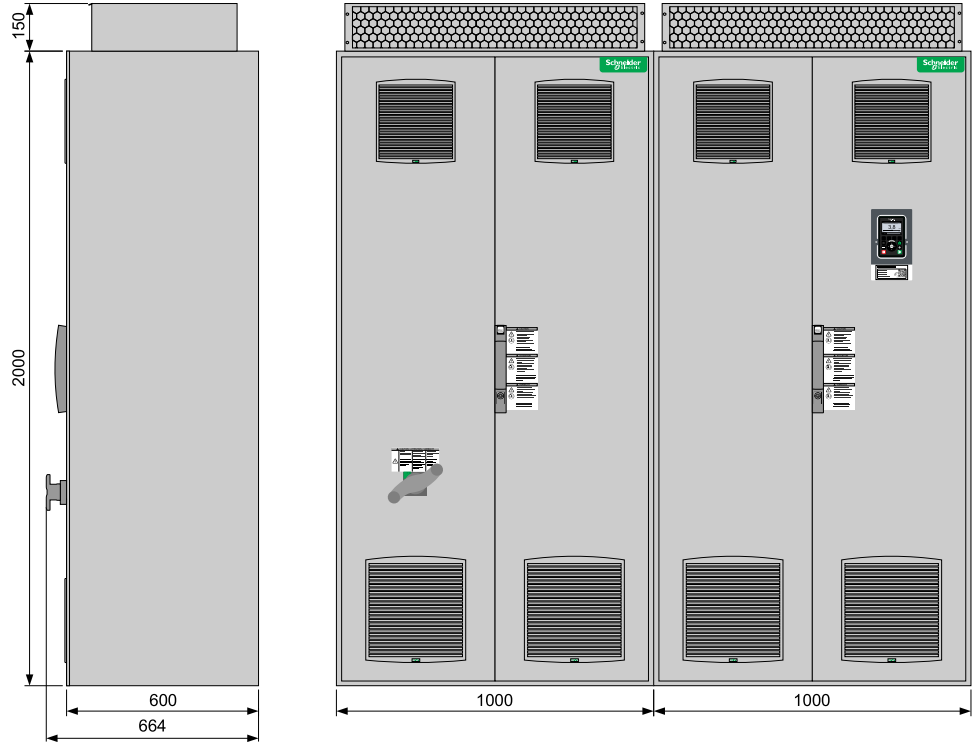

Interior View IP23 for Size 4a

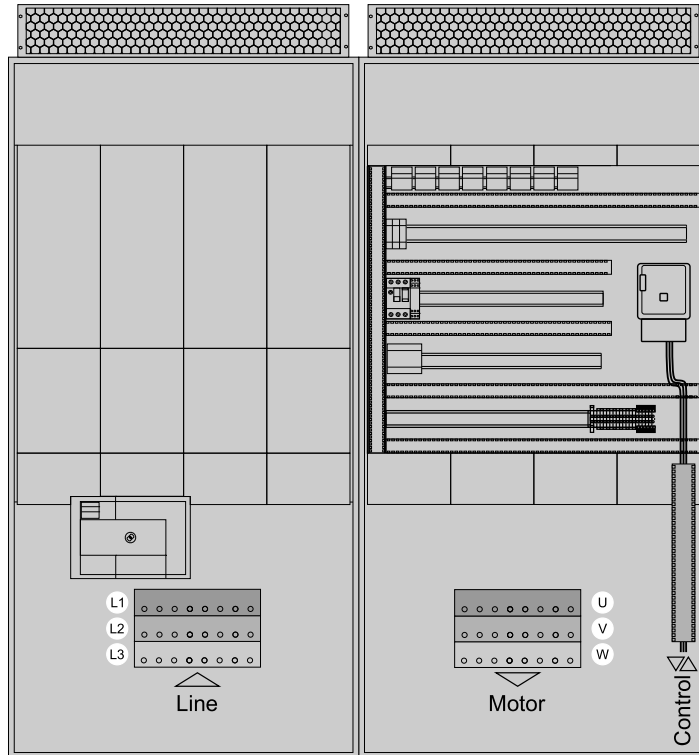

NOTE: Following customizations affect the total dimensions:

- Increased protection degree IP54
- Enclosure plinth for basic device
- Connection enclosure cable from top/ bottom

Technical Data ATV680C63•4X1

Type		ATV680C63•4X1	
Nominal data		Normal Duty ND	Heavy Duty HD ⁽¹⁾
Typical motor rating P_n	$U_n = 400\text{ V}$	630 kW	500 kW
	$U_n = 440\text{ V}$	630 kW	500 kW
	$U_n = 480\text{ V}$	710 kW	560 kW
Rated output current I_n		1140 A	900 A
Maximum current I_{MAX} for 60 s per 10 minutes		1254 A	1350 A
Input			
Rated input current I_{in} (at $I_{sc} = 50\text{ kA}$)	$U_n = 400\text{ V}$	971 A	775 A
	$U_n = 440\text{ V}$	883 A	704 A
	$U_n = 480\text{ V}$	912 A	723 A
Rated apparent power S_n	$U_n = 400\text{ V}$	673 kVA	537 kVA
	$U_n = 440\text{ V}$	673 kVA	537 kVA
	$U_n = 480\text{ V}$	758 kVA	601 kVA
Current harmonic THDi ⁽²⁾		< 5 %	
Protection for upstream cables			
Pre-fuse	$U_n = 400, 440, 480\text{ V}$	1250 A gG	1000 A gG
Circuit breaker I_{therm} / I_{magn}		1250 A / 12 kA	1000 A / 12 kA
Internal short-circuit protection			
Fuse	$U_n = 400, 440, 480\text{ V}$	4x 400 A aR	
Characteristics			
Efficiency at I_n		0.965	
Heat losses at I_n	Total losses	25630 W	19560 W
	Control part only	2930 W	2160 W
Weight	Net	1450 kg	
	Gross	1530 kg	
Ambient conditions			
Air flow	Power part	4640 m ³ /h	
	Control part	560 m ³ /h	
Sound pressure level		77 dB(A)	
Rated short-circuit current I_{sc}	Minimum ⁽³⁾	17 kA	
	Maximum ⁽⁴⁾	50 kA (100 ms)	
Mains and motor connection ⁽⁵⁾			
Typical cable		4x (3x 240 mm ²) or 5x (3x 185 mm ²) or 6x (3x 120 mm ²)	4x (3x 185 mm ²) or 5x (3x 120 mm ²)
Max. Cable cross section ⁽⁶⁾	Cable	5x (3x 240 mm ²) or 6x (3x 185 mm ²)	
	Cable entry mains ⁽⁷⁾	max. 760 mm	
	Cable entry motor ⁽⁷⁾	max. 760 mm	
Terminals per phase		8x M12	
<p>(1) For Heavy Duty HD operation parameter [Dual Rating] <i>drt</i> has to be set to [High rating] <i>HiGH</i> (see programming manual EAV64318).</p> <p>(2) For details see table under chapter Mains Current Harmonics / Mains Voltage Distortion, page 85.</p> <p>(3) Minimum mains short-circuit current</p> <p>(4) Permitted short-circuit current when the specified pre-fuse or circuit breaker is installed</p> <p>(5) You will find further information at chapter Mains Connection, page 82 and at chapter Motor Connection, page 86.</p> <p>(6) Greater connection cross sections are possible with the separate connection enclosure.</p> <p>(7) Maximum possible width of cables connected next to each other in the enclosure</p>			

Dimensions IP23 for Size 4a

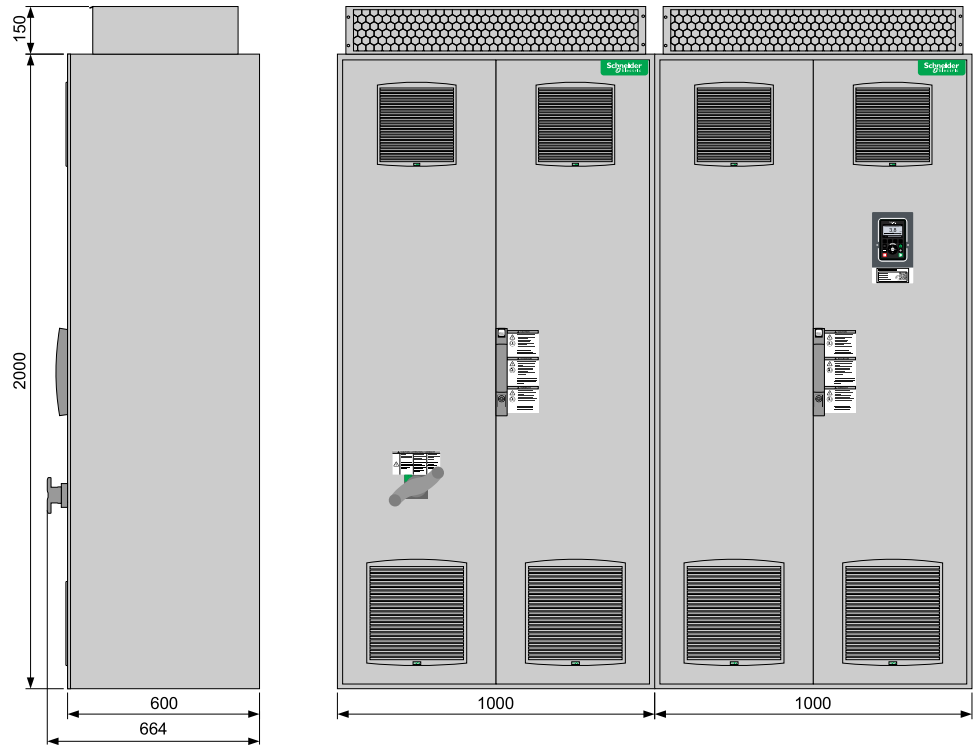

Interior View IP23 for Size 4a

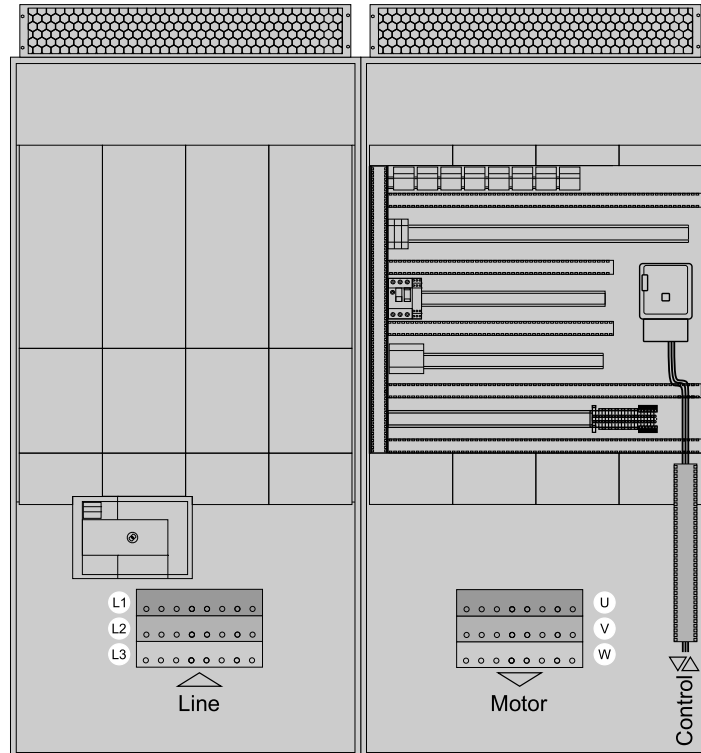

NOTE: Following customizations affect the total dimensions:

- Increased protection degree IP54
- Enclosure plinth for basic device
- Connection enclosure cable from top/ bottom

Technical Data ATV680C71•4X1

Type		ATV680C71•4X1	
Nominal data		Normal Duty ND	Heavy Duty HD ⁽¹⁾
Typical motor rating P_n	$U_n = 400\text{ V}$	710 kW	560 kW
	$U_n = 440\text{ V}$	710 kW	560 kW
	$U_n = 480\text{ V}$	800 kW	630 kW
Rated output current I_n		1260 A	1020 A
Maximum current I_{MAX} for 60 s per 10 minutes		1386 A	1530 A
Input			
Rated input current I_{in} (at $I_{sc} = 50\text{ kA}$)	$U_n = 400\text{ V}$	1094 A	868 A
	$U_n = 440\text{ V}$	995 A	789 A
	$U_n = 480\text{ V}$	1028 A	813 A
Rated apparent power S_n	$U_n = 400\text{ V}$	758 kVA	601 kVA
	$U_n = 440\text{ V}$	758 kVA	601 kVA
	$U_n = 480\text{ V}$	854 kVA	676 kVA
Current harmonic THDi ⁽²⁾		< 5 %	
Protection for upstream cables			
Pre-fuse	$U_n = 400, 440, 480\text{ V}$	1600 A gG	1250 A gG
Circuit breaker I_{therm} / I_{magn}		1400 A / 14 kA	1100 A / 14 kA
Internal short-circuit protection			
Fuse	$U_n = 400, 440, 480\text{ V}$	5x 400 A aR	
Characteristics			
Efficiency at I_n		0.965	
Heat losses at I_n	Total losses	28230 W	21850 W
	Control part only	3230 W	2450 W
Weight	Net	1950 kg	
	Gross	2045 kg	
Ambient conditions			
Air flow	Power part	5800 m ³ /h	
	Control part	700 m ³ /h	
Sound pressure level		78 dB(A)	
Rated short-circuit current I_{sc}	Minimum ⁽³⁾	18 kA	
	Maximum ⁽⁴⁾	50 kA (100 ms)	
Mains and motor connection ⁽⁵⁾			
Typical cable		5x (3x 185 mm ²) or 6x (3x 150 mm ²)	4x (3x 185 mm ²) or 5x (3x 150 mm ²)
Max. Cable cross section ⁽⁶⁾	Cable	6x (3x 240 mm ²) or 8x (3x 150 mm ²)	
	Cable entry mains ⁽⁷⁾	max. 760 mm	
	Cable entry motor ⁽⁷⁾	max. 760 mm	
Terminals per phase		10x M12	
<p>(1) For Heavy Duty HD operation parameter [Dual Rating] <i>drt</i> has to be set to [High rating] <i>HiGH</i> (see programming manual EAV64318).</p> <p>(2) For details see table under chapter Mains Current Harmonics / Mains Voltage Distortion, page 85.</p> <p>(3) Minimum mains short-circuit current</p> <p>(4) Permitted short-circuit current when the specified pre-fuse or circuit breaker is installed</p> <p>(5) You will find further information at chapter Mains Connection, page 82 and at chapter Motor Connection, page 86.</p> <p>(6) Greater connection cross sections are possible with the separate connection enclosure.</p> <p>(7) Maximum possible width of cables connected next to each other in the enclosure</p>			

Dimensions IP23 for Size 5a



Interior View IP23 for Size 5a

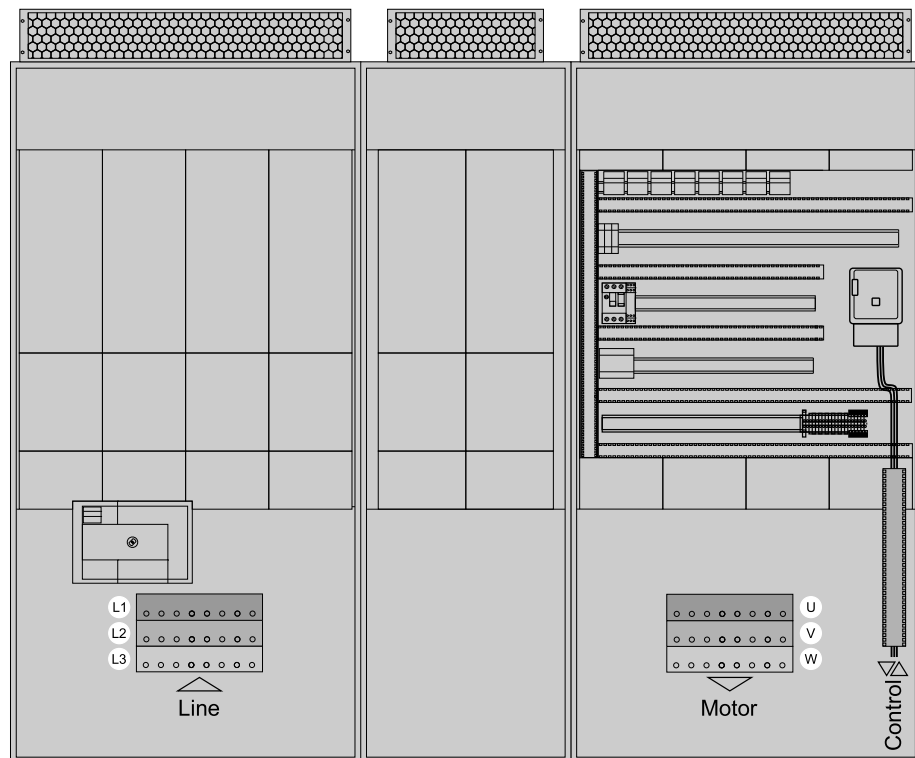

NOTE: Following customizations affect the total dimensions:

- Increased protection degree IP54
- Enclosure plinth for basic device
- Connection enclosure cable from top/ bottom

Technical Data ATV680C80•4X1

Type		ATV680C80•4X1	
Nominal data		Normal Duty ND	Heavy Duty HD ⁽¹⁾
Typical motor rating P_n	$U_n = 400\text{ V}$	800 kW	630 kW
	$U_n = 440\text{ V}$	800 kW	630 kW
	$U_n = 480\text{ V}$	900 kW	710 kW
Rated output current I_n		1420 A	1140 A
Maximum current I_{MAX} for 60 s per 10 minutes		1562 A	1710 A
Input			
Rated input current I_{in} (at $I_{sc} = 50\text{ kA}$)	$U_n = 400\text{ V}$	1227 A	971 A
	$U_n = 440\text{ V}$	1115 A	883 A
	$U_n = 480\text{ V}$	1150 A	912 A
Rated apparent power S_n	$U_n = 400\text{ V}$	850 kVA	673 kVA
	$U_n = 440\text{ V}$	850 kVA	673 kVA
	$U_n = 480\text{ V}$	956 kVA	758 kVA
Current harmonic THDi ⁽²⁾		< 5 %	
Protection for upstream cables			
Pre-fuse	$U_n = 400, 440, 480\text{ V}$	1600 A gG	1250 A gG
Circuit breaker I_{therm} / I_{magn}		1600 A / 16 kA	1250 A / 16 kA
Internal short-circuit protection			
Fuse	$U_n = 400, 440, 480\text{ V}$	5x 400 A aR	
Characteristics			
Efficiency at I_n		0.965	
Heat losses at I_n	Total losses	32580 W	24580 W
	Control part only	3780 W	2780 W
Weight	Net	1950 kg	
	Gross	2045 kg	
Ambient conditions			
Air flow	Power part	5800 m ³ /h	
	Control part	700 m ³ /h	
Sound pressure level		78 dB(A)	
Rated short-circuit current I_{sc}	Minimum ⁽³⁾	20 kA	
	Maximum ⁽⁴⁾	50 kA (100 ms)	
Mains and motor connection ⁽⁵⁾			
Typical cable		5x (3x 240 mm ²) or 6x (3x 185 mm ²)	4x (3x 240 mm ²) or 5x (3x 185 mm ²) or 6x (3x 120 mm ²)
Max. Cable cross section ⁽⁶⁾	Cable	6x (3x 240 mm ²) or 8x (3x 150 mm ²)	
	Cable entry mains ⁽⁷⁾	max. 760 mm	
	Cable entry motor ⁽⁷⁾	max. 760 mm	
Terminals per phase		10x M12	
<p>(1) For Heavy Duty HD operation parameter [Dual Rating] <i>drt</i> has to be set to [High rating] <i>HiGH</i> (see programming manual EAV64318).</p> <p>(2) For details see table under chapter Mains Current Harmonics / Mains Voltage Distortion, page 85.</p> <p>(3) Minimum mains short-circuit current</p> <p>(4) Permitted short-circuit current when the specified pre-fuse or circuit breaker is installed</p> <p>(5) You will find further information at chapter Mains Connection, page 82 and at chapter Motor Connection, page 86.</p> <p>(6) Greater connection cross sections are possible with the separate connection enclosure.</p> <p>(7) Maximum possible width of cables connected next to each other in the enclosure</p>			

Dimensions IP23 for Size 5a

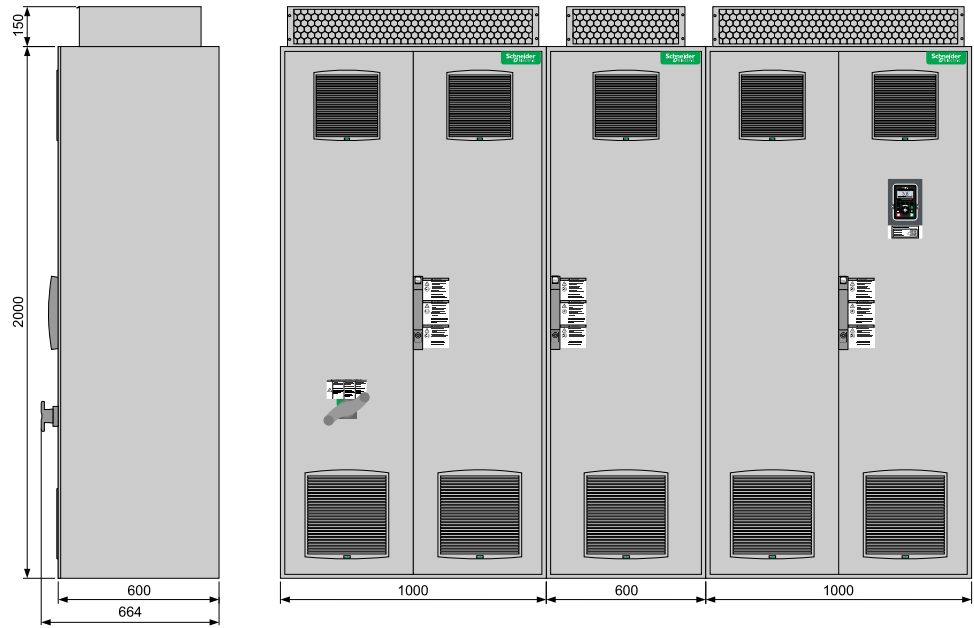

Interior View IP23 for Size 5a

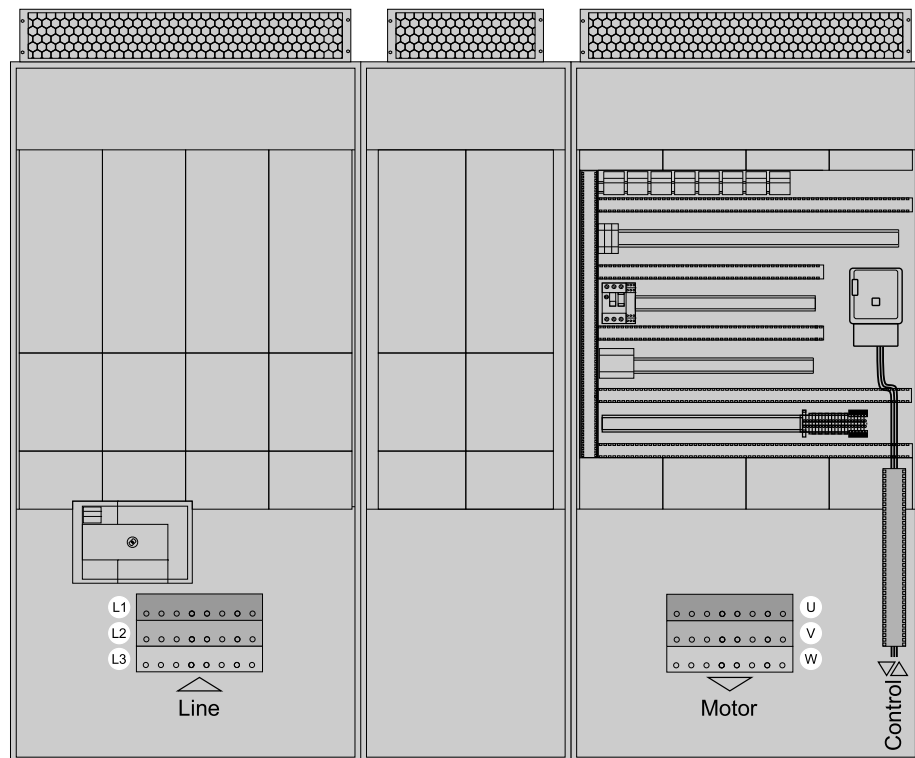

NOTE: Following customizations affect the total dimensions:

- Increased protection degree IP54
- Enclosure plinth for basic device
- Connection enclosure cable from top/ bottom

Circuit Diagram

The following diagram shows the typical wiring of the frequency inverter including the options which may be required for protection of the plant or the device, depending on the use case.

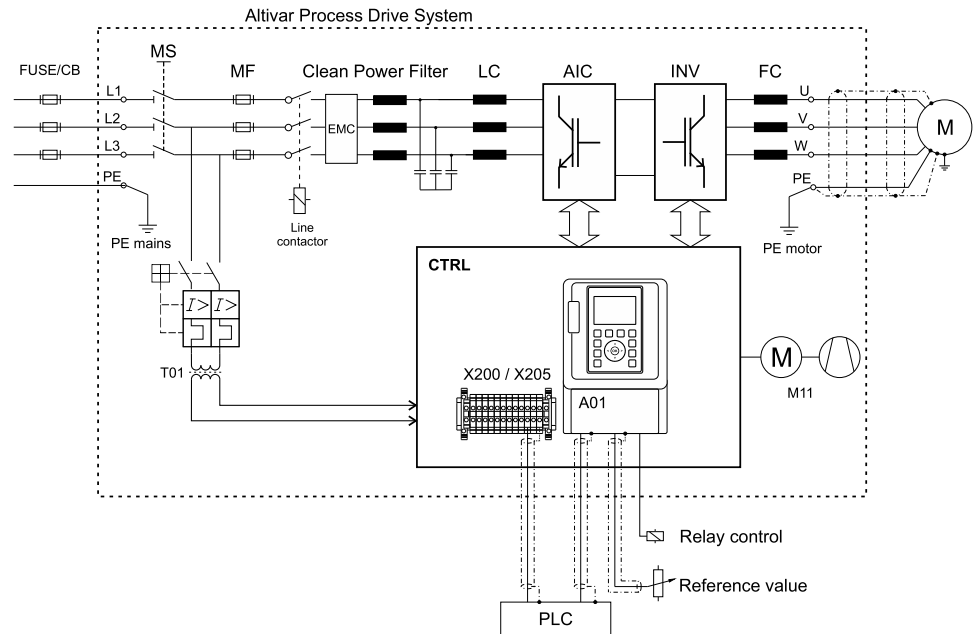

- ATV680** Altivar Process Drive Systems
- FUSE/CB** External pre-fuse or circuit breaker to protect the mains cable
- MS** Built-in main switch, lockable in open position
- T01** Control transformer 400 / 230 V AC
- MF** aR fuses for short-circuit shut-down if the electronic protective devices do not work properly
- Clean Power Filter** Clean Power Filter with integrated EMC filter
- LC** Filter choke
- AIC** Active Infeed Converter module(s)
- INV** Inverter module(s)
- FC** dv/dt filter choke to reduce the voltage load of the motor (at some types a "dv/dt filter choke" is already integrated)
- CTRL** Control panel with control block and further control components
- A01** Control terminals at the control block
- X200 / X205** Control terminals at the control panel
- M11** Fan in enclosure door

Mains Connection

What's in This Chapter

Dimensioning of the Power Cables	83
Overcurrent- and Short-circuit Protection	84
Mains Current Harmonics / Mains Voltage Distortion	85



Dimensioning of the Power Cables

The Altivar Process Drive Systems include semiconductor fuses as standard. These fuses are for the case that the electronic protective mechanisms of the inverter do not work. So they are a secondary protection of the inverter.

The Altivar Process Drive Systems help to protect themselves as well as the mains cables and the motor cables against thermal overload. The specified pre-fuses or circuit breakers (with magnetic release) must be installed upstream to protect the mains cables against short-circuit.

The recommended values for dimensioning the cable cross sections given in chapter *Specification*, page 52 are reference values for multi-core copper power cables laid in air at a maximum ambient temperature of 40°C (104°F). Observe different ambient conditions and local regulations.

Recommended types of mains cables

Cable Type	Description
	Three-phase cable with sector-shaped conductors and reduced protective conductor. NOTE: Verify that the PE conductor complies with the requirements according to IEC 61439-1.
	Three-phase cable with round conductors and reduced protective conductor. NOTE: Verify that the PE conductor complies with the requirements according to IEC 61439-1.

⚠ WARNING

OVERLOAD DUE TO INCORRECT RATING OF MAINS SUPPLY

- Install properly rated upstream mains fuses or circuit breakers.
- When rating the upstream mains fuses and the cross sections as well as the lengths of the mains cables, take into account the available specified short circuit current.
- If the required short circuit is not available, increase the power of the transformer.

Failure to follow these instructions can result in death, serious injury, or equipment damage.

Overcurrent- and Short-circuit Protection

The following picture illustrates the overcurrent protection and short-circuit protection at the input side.

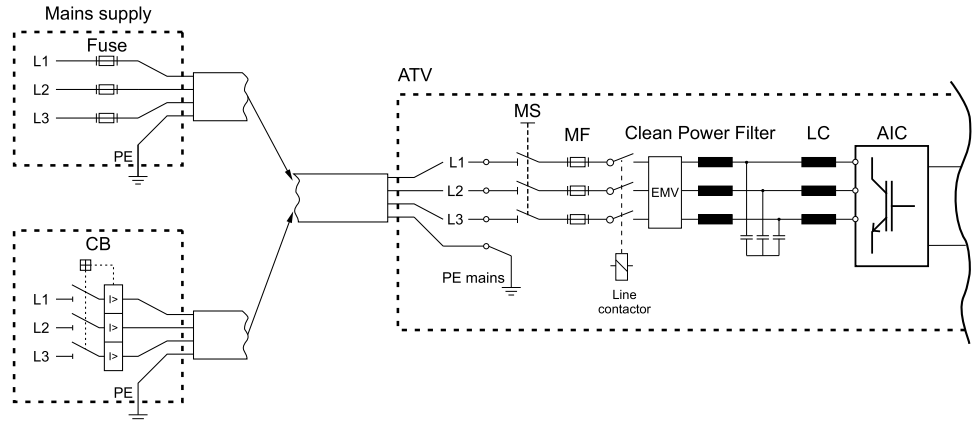

- ATV** Altivar Process Drive Systems
- FUSE** External pre-fuse to protect the mains cable
- CB** External circuit breaker to protect the mains cable (alternatively to FUSE)
- MS** Built-in main switch, lockable in open position
- MF** aR mains fuses for short-circuit shut-down if the electronic protective devices do not work properly
- Clean Power Filter** Clean Power Filter with integrated EMC filter
- LC** Filter choke
- AIC** Active Infeed Converter module(s)

The Altivar Process Drive System includes semiconductor fuses as standard. These fuses are for the case that the electronic protective mechanisms of the inverter do not work. So they are a secondary protection of the inverter.

The opening of the branch circuit protective device may be an indication that a fault current has been interrupted.

⚡ ⚠ **DANGER**

HAZARD OF ELECTRIC SHOCK, EXPLOSION, OR ARC FLASH

Current-carrying parts and other components of the controller should be examined and replaced if damaged before switching the system on again.

Failure to follow these instructions will result in death or serious injury.

NOTE: The overcurrent protection is given at the technical data of the respective Altivar Process Drive System, page 52.

Mains Current Harmonics / Mains Voltage Distortion

Because of using a diode rectifier on the input of a conventional inverter, harmonics occur in the mains current which lead to a voltage distortion of the supplying mains.

The ATV680 Low Harmonic Drive Systems are equipped with an active mains supply module. So these typical harmonic currents of the frequency inverter do not occur anymore.

The new 3-level technology inside the ATV680 Low Harmonic Drive System reaches a total harmonic distortion THD(i) of around 2 % and thus fulfills the requirements according to IEEE 519 of $THD(i) < 5\%$ also in case of distorted mains. This low total harmonic distortion THD(i) is reached during mains supply operation as well as during regenerating operation.

$\cos \Phi \approx 1$ is reached in each load situation (from 30 % P_n) and additionally helps to reduce the load of the mains.

This table represents typical values of the individual current harmonics at operation with the ATV680 Low Harmonic Drive Systems.

Operating mode	Current harmonics in % ⁽¹⁾																	
	H1	H5	H7	H11	H13	H17	H19	H23	H25	H29	H31	H35	H37	H41	H43	H47	H49	THD
Motor	100	1.29	1.05	0.38	0.21	0.20	0.19	0.34	0.19	0.11	0.09	0.15	0.12	0.19	0.18	0.07	0.04	2.2
Generator	100	1.26	0.78	0.39	0.33	0.69	0.60	0.28	0.40	0.22	0.22	0.16	0.20	0.18	0.09	0.04	0.04	2.1

(1) Values are valid for operation at nominal load and sinusoidal mains voltage.

Motor Connection

What's in This Chapter

Assignment of the Motor	87
Dimensioning of the Motor Cables	88
Length of Motor Cables	89
Thermal Motor Monitoring	93

Assignment of the Motor

All Altivar Process Drive Systems include the function "Dual rating". It enables the use for drives with low overload "Normal duty" (typically pumps and fans) and, on the other hand, also the use with increased requirements regarding overload capability, starting torque, load impacts and control performance "Heavy duty" (e.g. compressors, mixers, rotary blowers,...).

You can select the desired power/overload capability with parameter **[Dual rating] DRT**. When changing this parameter all relevant parameters are adapted to the selected property. For example, the parameters for motor power and motor current are modified accordingly.

In case of setting HD – Heavy Duty **[High rating] HIGH** the overload capability and the maximum overload current are increased. But at the same time the nominal motor power and the continuous output current of the frequency inverter are reduced. So you have to select a higher device type for the same motor power.

Example for ATV680C13Q4X1:

Normal Duty ND:

132 kW with 250 A continuous current and 275 A overload current for 60 s

- Nominal power
- Overload 10 %
- Factory setting: **[Normal rating] NORMAL**

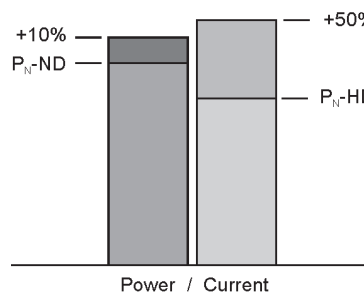

Heavy Duty HD:

110 kW with 211 A continuous current and 317 A overload current for 60 s

- Lower nominal power
- Overload 50 %
- Selectable via parameter: **[High rating] HIGH**

The factory setting of the parameter **[Dual rating] DRT** is "Normal Duty". When the product is reset to the factory settings, this parameter is also reset to "Normal Duty".

Dimensioning of the Motor Cables

 **DANGER**

ELECTRIC SHOCK DUE TO OVERLOAD ON MOTOR CABLES

- Verify that the protective ground conductor complies with the requirements specified in IEC 61439-1.
- Verify compliance of the motor cables with the specification of IEC 60034-25.



Failure to follow these instructions will result in death or serious injury.

The recommended values for dimensioning the cable cross sections given in chapter Specification, page 52 are reference values for multi-core copper power cables laid in air at a maximum ambient temperature of 40°C (104°F). Observe different ambient conditions and local regulations.

The motor cables are dimensioned for the maximum continuous current. They apply to 0...100 Hz (up to 300 Hz the cable losses increase about 25 % because of the Skin-effect).

The IGBT modules cause high-frequent interferences which drain off more and more stronger to the ground potential with increasing motor cable length. As a result the line-conducted interferences to the mains increase. In case of too long motor cables the attenuation of the mains filters is not longer sufficient and the permitted interference limits are exceeded.

Recommended types of motor cables

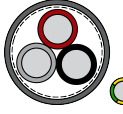
Cable Type	Description
	Symmetrically shielded cable with 3 phase conductors, symmetrically arranged PE conductor and a shield. NOTE: Verify that the PE conductor complies with the requirements according to IEC 61439-1. Example: 2YSLCY-JB
	Symmetrically shielded cable with 3 phase conductors and a concentric PE conductor as shield. NOTE: Verify that the PE conductor complies with the requirements according to IEC 61439-1. Example: NYCY / NYCWY
	Three-phase cable with round conductors and reduced protective conductor. NOTE: A separate PE conductor is required if the shield does not fulfill the requirements according to IEC 61439-1.

NOTE: Shielded single-conductor cables are not recommended due to increased currents in the shield.

Length of Motor Cables

Because of the permitted mains disturbances, the allowed overvoltages at the motor, the occurring bearing currents and the permitted heat losses the distance between inverter and motor(s) is limited. The maximum distance heavily depends on the used motors (insulation material), the type of motor cable used (shielded/unshielded), the cable laying (cable channel, underground installation, ...) as well as from the used options.

Dynamic voltage load of the motor

Overvoltages at the motor terminals result from reflection in the motor cable. Basically the motors are stressed with measurable higher voltage peaks from a motor cable length of 10 m. With the length of the motor cable also the value of overvoltage increases.

The steep edges of the switching impulses at the output side of the frequency inverter lead to a further load of the motors. The slew rate of the voltage is typically over 5 kV/μs but it decreases with the length of the motor cable.

The ATV680 frequency inverters are equipped with a dv/dt filter choke (at higher types a "dv/dt filter choke" is already integrated), which significantly reduces the load of the motors and so it is in accordance with the allowed limits.

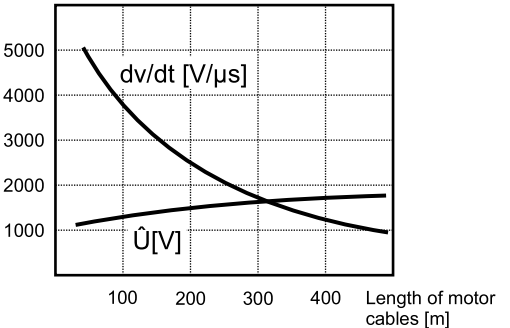
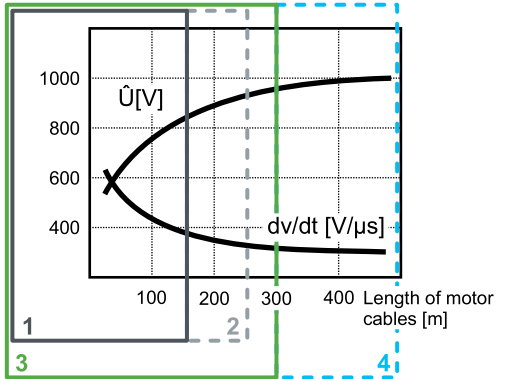
Typical load of the motor ⁽¹⁾	Description
	<p>Load of the motor with overvoltage and slew rate when using conventional frequency inverters without integrated dv/dt filter chokes.</p>
	<p>Reduced load of the motor by using Altivar Process Drive Systems with integrated dv/dt filter chokes 150 m (at higher types a "dv/dt filter choke" is already integrated).</p> <ol style="list-style-type: none"> 1 When using a shielded motor cable 2 When using an unshielded motor cable 3 When using a shielded motor cable and a "dv/dt filter choke 300 m". 4 When using an unshielded motor cable and a "dv/dt filter choke 300 m".
<p>(1) The given values are related to the voltage load phase-to-phase. The voltage values phase to ground are approximately 300 V lower, du/dt is approximately 150 V/μs lower.</p>	

The motor standards for IEC and NEMA specify limits for the permitted load regarding slew rate and voltage peaks

- IEC 60034-17 – Permitted values for standard power supply driven motors at the frequency inverter, up to 500 V
- IEC 60034-25 – Permitted values for "inverter motors" up to 500 V
- NEMA MG1 – Permitted values for "inverter motors"

Typical measured values	Description
<p>The graph plots voltage slew rate \dot{U} [kV] on the y-axis (0.5 to 2.0) against rise time t_r [μs] on the x-axis (0.2 to 1.0). Three curves represent different standards: IEC60034-25 (highest), IEC60034-17 (middle), and NEMA MG1 (lowest). Cable lengths of 5m, 20m, 30m, 50m, and 100m are marked with 'x' symbols. Voltage levels of 1.2kV, 1.56kV, and 1.35kV are also indicated.</p>	<p>The typical measured values as shown in the diagram correspond with the ATV680 frequency inverter variant with built-in dv/dt filter choke 150 m (at higher types a "dv/dt filter choke" is already integrated).</p>

Motors according IEC 60034-25 as well as motors according NEMA MG1 are dimensioned for operation with frequency inverters and thus they are well qualified for drives with ATV680 frequency inverters.

Motors according IEC 60034-17 are dimensioned for operation with pure sinusoidal voltage, but they can also be operated at ATV680 when observing the permitted cable lengths and correct customization.

The Low Harmonic Drive Systems ATV680 and ATV980 offer significant improvement regarding motor load in comparison with older generations with active mains rectifiers AFE (as still offered from many competitors). By the new "3-level" system architecture the voltage load is the same as for ATV660 and ATV960 with classic diode rectifiers and so it not required to take it into account separately.

Basically for all motors from frame size 315 (approximately 110 kW) an insulated bearing on the non-drive end is recommended. It helps to prevent internal current flow inside the motor which can result from unbalances. The insulated bearing is to be understood as supplement to the dv/dt filter choke inside the frequency inverter.

NOTICE

OVERVOLTAGE AT THE MOTOR

Do not exceed the maximum length of the motor cables as specified in this document.

Failure to follow these instructions can result in equipment damage.

EMC interferences

The IGBT modules cause high-frequency interferences which drain off more and more strongly to the ground potential with increasing motor cable length. As a result the line-conducted interferences to the mains increase. In case of too long motor cables the attenuation of the mains filters is no longer sufficient and the permitted interference limits are exceeded.

The IGBT modules cause high-frequency interference which increases with increasing motor cable length. If the motor cable length exceeds the maximum cable length, the internal mains filters are no longer sufficient.

▲ WARNING

UNEXPECTED EQUIPMENT OPERATION DUE TO HIGH-FREQUENCY INTERFERENCE

Do not exceed the maximum length of the motor cables as specified in this document.

Failure to follow these instructions can result in death, serious injury, or equipment damage.

Limit values

This product meets the EMC requirements according to the standard IEC 61800-3 if the measures described in this manual are implemented during installation.

If the selected composition (product itself, mains filter, other accessories and measures) does not meet the requirements of category C1, the following information applies as it appears in IEC 61800-3:

▲ WARNING

RADIO INTERFERENCE

In a domestic environment this product may cause radio interference in which case supplementary mitigation measures may be required.

Failure to follow these instructions can result in death, serious injury, or equipment damage.

Bearing currents

The dv/dt filter choke inside the ATV680 frequency inverter effects a significant reduction of the common mode bearing currents.

Especially in case of big motors with middle up to high motor cable lengths the filter chokes are considerable to increase the availability of the motor.

Multiplication factors

In case of conditions differing from the table the recommended cable lengths have to be converted by means of the following factors.

If several factors apply, please multiply them.

		Correction of the max. cable lengths
The pulse frequency does not correspond to factory setting:	at 4 kHz	multiply all values by 0.70
	at 8 kHz	multiply all values by 0.40
Output frequencies higher than 100 Hz.	up to 200 Hz	multiply all values by 0.80
	up to 300 Hz	multiply all values by 0.50
In case of 6-pole motor cabling (e.g. for star/delta starting circuit)		multiply all values by 0.75
In case of parallel motors with a dedicated cable to each motor the inverter values have to be converted in compliance with the number of motors. When a motor choke is used for each motor, the following values in brackets apply.	at 2 motors	multiply all values by 0.40 (0.80)
	at 3 motors	multiply all values by 0.25 (0.60)
	at 4 motors	multiply all values by 0.15 (0.40)
	at 5 motors	multiply all values by 0.10 (0.25)
In case of parallel motors with a common cable to all motors the inverter values have to be converted in compliance with the number of motors:	at 2 motors	multiply all values by 0.80
	at 3 motors	multiply all values by 0.60
	at 4 motors	multiply all values by 0.40
	at 5 motors	multiply all values by 0.25

Recommended maximum lengths of motor cables in second environment (industrial environment)

EMC category (EN 61800-3)	ATV680	Chosen option	Type of cable	Max. cable length
C3	C11●4X1...C16●4X1	-	Shielded	50 m
	C11●4X1...C16●4X1	dv/dt filter choke 150m	Shielded	150 m
	C20●4X1...C80●4X1	- (1)	Shielded	150 m
C4	C11●4X1...C16●4X1	-	Unshielded	100 m
	C11●4X1...C16●4X1	dv/dt filter choke 150m	Unshielded	250 m
	C20●4X1...C80●4X1	- (1)	Unshielded	250 m
	C11●4X1...C80●4X1	dv/dt filter choke 300m	Shielded	300 m
	C11●4X1...C80●4X1	dv/dt filter choke 300m	Unshielded	500 m
(1) At ATV680 Drive Systems from 200 kW the dv/dt filter choke 150m is built-in as standard.				

NOTE: The specified lengths of motor cables are recommended limits based on typical motor cables, laying in cable channels, default pulse frequency and maximal output frequency of 100 Hz. Longer cable lengths are possible on request.

Thermal Motor Monitoring

In the Altivar Process Drive System several possibilities for thermal motor monitoring are available:

- Standard sensor inputs AI2, AI3 at the control block Suitable temperature sensors: PTC, Pt100, Pt1000, KTY84
- Sensor inputs AI4, AI5 at expansion card "Logic and analog I/O card" Suitable temperature sensors: PTC, Pt100, Pt1000, KTY84

DANGER

HAZARD OF ELECTRIC SHOCK, EXPLOSION OR ARC FLASH

- Verify that the temperature sensors in the motor meet the PELV requirements.
- Verify that the motor encoder meets the PELV requirements.
- Verify that any other equipment connected via signal cables meets the PELV requirements.

Failure to follow these instructions will result in death or serious injury.

- On customer request the motor monitoring PTC, a PTC thermistor relay (alternatively with ATEX certificate), is installed and the sensor inputs are wired with the option terminals. The evaluation is performed via the diagnostics system in the Altivar Process Drive System.
- On customer request the motor/bearing monitoring Pt100/Pt1000/KTY is installed, which includes evaluation relays and the wiring of the sensor inputs to the option terminals. The evaluation is performed via the diagnostics system in the Altivar Process Drive System.

NOTE: When protective separation of the thermistor sensors in the motor cannot be guaranteed or in case of long motor cables, this option is highly recommended.

Predefined Customizations

Customization / Page	Brief description
Enclosure options	
Increased protection degree IP54, page 123	Enclosure designed in increased protection degree IP54
Enclosure plinth, page 124	Enclosure plinth for basic device in protection degree IP23
Connection enclosure, page 124	Separate connection enclosure; for connection of cables alternatively from top or from bottom.
Enclosure lighting, page 125	Fluorescent lamp and a power socket 230 V AC
Enclosure heating, page 125	Heats the enclosure in order to avoid frost and condensation at an ambient temperature up to -10°C
Modified wiring colors, page 126	Modified wiring colors at the power cables
Control options	
Key switch "local / remote", page 128	Key switch in the enclosure door for switching between remote control and local control
Ethernet port on front door, page 128	Access to the Ethernet network directly on the enclosure door
I/O expansion cards	
Logic and analog I/O card, page 130	Expansion card for additional analog and digital inputs and outputs (6 digital inputs, 2 digital outputs, 2 analog inputs)
Relay output card, page 130	Expansion card with three additional relay outputs
Communication cards	
Communication card Modbus TCP or EtherNet IP, page 132	Dual port option card for control of the inverter via Modbus TCP or EtherNet/IP
Communication card CANopen Daisy Chain, page 132	Option card for control of the inverter via CANopen Daisy Chain
Communication card CANopen SUB-D9, page 132	Option card for control of the inverter via CANopen with SUB-D port
Communication card CANopen with screw terminals, page 132	Option card for control of the inverter via CANopen with screw terminals
Communication card DeviceNet, page 132	Option card for control of the inverter via DeviceNet
Communication card Profibus DP, page 133	Option card for control of the inverter via Profibus DP V1
Communication card PROFINET, page 133	Option card for control of the inverter via PROFINET
Functional safety	
STO - SIL 3 Stop category 0, page 135	This option effects a Safe Torque Off at the motor
STO - SIL 3 Stop category 1, page 135	This option effects a Safe Torque Off at the motor with controlled deceleration
Display options	
Front Display Module (FDM), page 137	Measuring device mounted in the enclosure door which indicates the operating data
Indicator lamps on front door, page 137	Three additional Indicator lamps mounted in the enclosure door which indicate the operating state
Motor options	
Motor monitoring PTC, page 139	PTC thermistor relay to monitor the motor temperature via PTC thermistors in the motor
Motor monitoring PTC with ATEX certificate, page 139	PTC thermistor relay to monitor the motor temperature via PTC thermistors in the motor with ATEX certificate
Motor monitoring Pt100/Pt1000/KTY, page 139	Tripping unit to monitor the motor temperature via Pt100/Pt1000/KTY sensors in the motor winding
Bearing monitoring Pt100/Pt1000/KTY, page 140	Tripping unit to monitor the motor temperature via Pt100/Pt1000/KTY sensors in the bearings of the motor
dv/dt filter choke 150 m, page 140	Reduces the slew rate, peak voltage and common mode interferences on the output of the inverter and helps to protect the motor
dv/dt filter choke 300 m, page 140	Helps to protect the motor winding and motor bearings in case of very long motor cable

Customization / Page	Brief description
Motor heating, page 141	Includes a motor circuit breaker, a contactor and the terminals to connect a motor heating
Mains supply	
Circuit breaker, page 143	Mains disconnect unit instead of the main switch, including door handle
Undervoltage coil for circuit breaker 230 V, page 143	When there is no voltage at the undervoltage coil, the circuit breaker switches off
Motor for circuit breaker 230 V, page 144	Remote control of the circuit breaker via control commands is possible by means of this motor drive.
Monitoring	
EcoStruxure Asset Advisor, page 145	EcoStruxure Asset Advisor preventive services is a cloud based monitoring and smart alarming services.
Documentation / Packaging	
Safety labels in local language, page 148	With this option the devices can be ordered with labels in the local language.
Seaworthy packaging, page 148	This option contains a seaworthy packaging for transport by ship.

Wiring of the Control Terminals

What's in This Part

Design/Position of the Individual Terminals.....	97
Control Block	100
Option "Logic and Analog I/O Card"	112
Option "Relay Output Card".....	116
Option Terminals	118

Design/Position of the Individual Terminals

What's in This Chapter

Overview	98
Voltage Supply and Auxiliary Voltage	99

Overview

The Altivar Process Drive Systems are already equipped with extensive terminals on the control block as standard. The use and the function of all inputs and outputs can be parameterized.

In addition, there are the terminals X200 and X205, which are wired internally appropriate to the customizations.

For expansion the option cards Logic and analog I/O card and the relay output card are available. Both expansion cards can be installed, but the same card cannot be plugged twice.

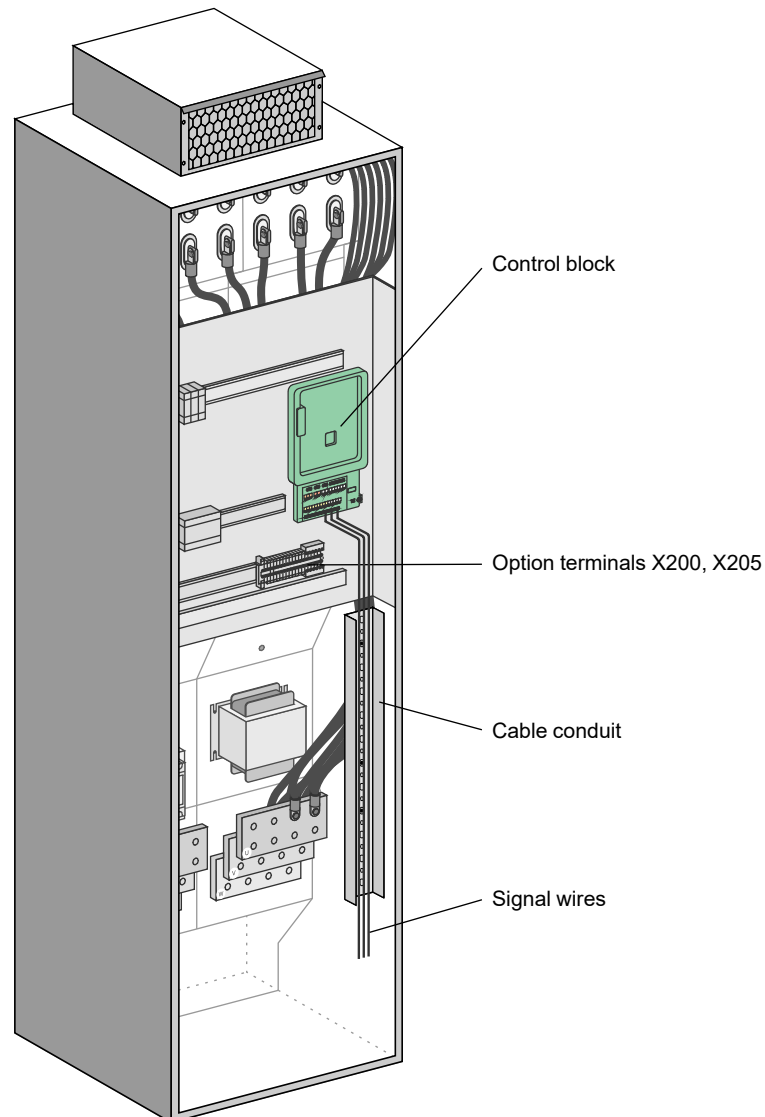

Voltage Supply and Auxiliary Voltage

All Drive Systems are equipped with a control transformer matching with the mains voltage and the required power. It provides a 230 Vac control voltage for supplying the fans in the enclosure doors and the DC supply units. The DC supply units generate 48 Vdc for the internal power part fans and a 24 Vdc auxiliary voltage. All control components are supplied by the internally provided voltages.

NOTE: For buffering the control block and with that keeping communication alive (e.g. fieldbus), the control block can be supplied via the terminals P24 and 0V externally with 24 Vdc.

DANGER

ELECTRIC SHOCK CAUSED BY INCORRECT POWER SUPPLY UNIT

The +24VDC supply voltage is connected with many exposed signal connections in the device.

- Use a power supply unit that meets the PELV (Protective Extra Low Voltage) requirements.

Failure to follow these instructions will result in death or serious injury.

Control Block

What's in This Chapter

Structure of the Control Block	101
Control Terminals at the Control Block.....	102
Specification of the Control Terminals	103
Relay Contacts Wiring	107
Digital Inputs Wiring Depending on Sink / Source Switch Configuration	110

Structure of the Control Block

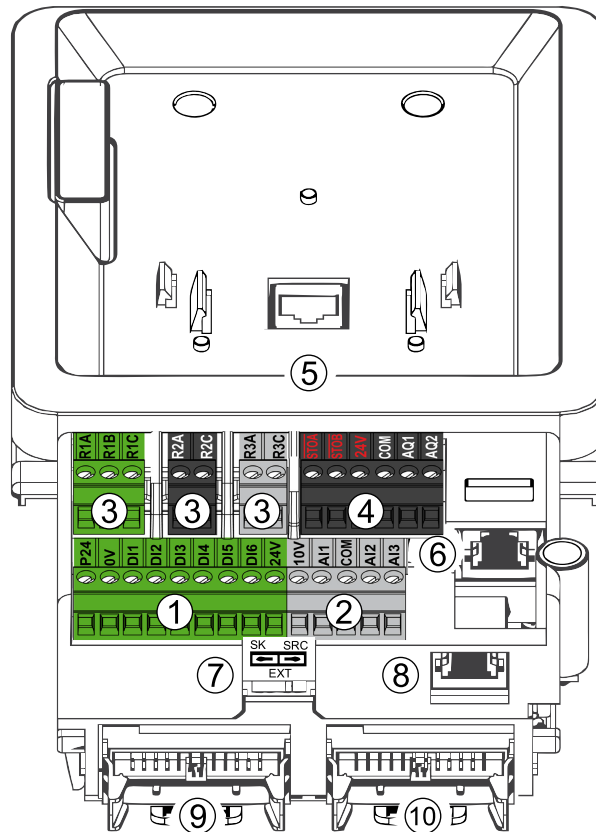

- 1 Control terminals of digital inputs
- 2 Control terminals of analog inputs
- 3 Control terminals of relay outputs
- 4 Control terminals STO (Safe Torque Off) and analog outputs
- 5 RJ45 port for the graphical keypad
- 6 RJ45 port for Ethernet IP or Modbus TCP
- 7 Sink-Ext-Source selector switch
- 8 RJ45 port for serial Modbus
- 9 Slot B for I/O expansion card
- 10 Slot A for communication card or I/O expansion card

Control Terminals at the Control Block

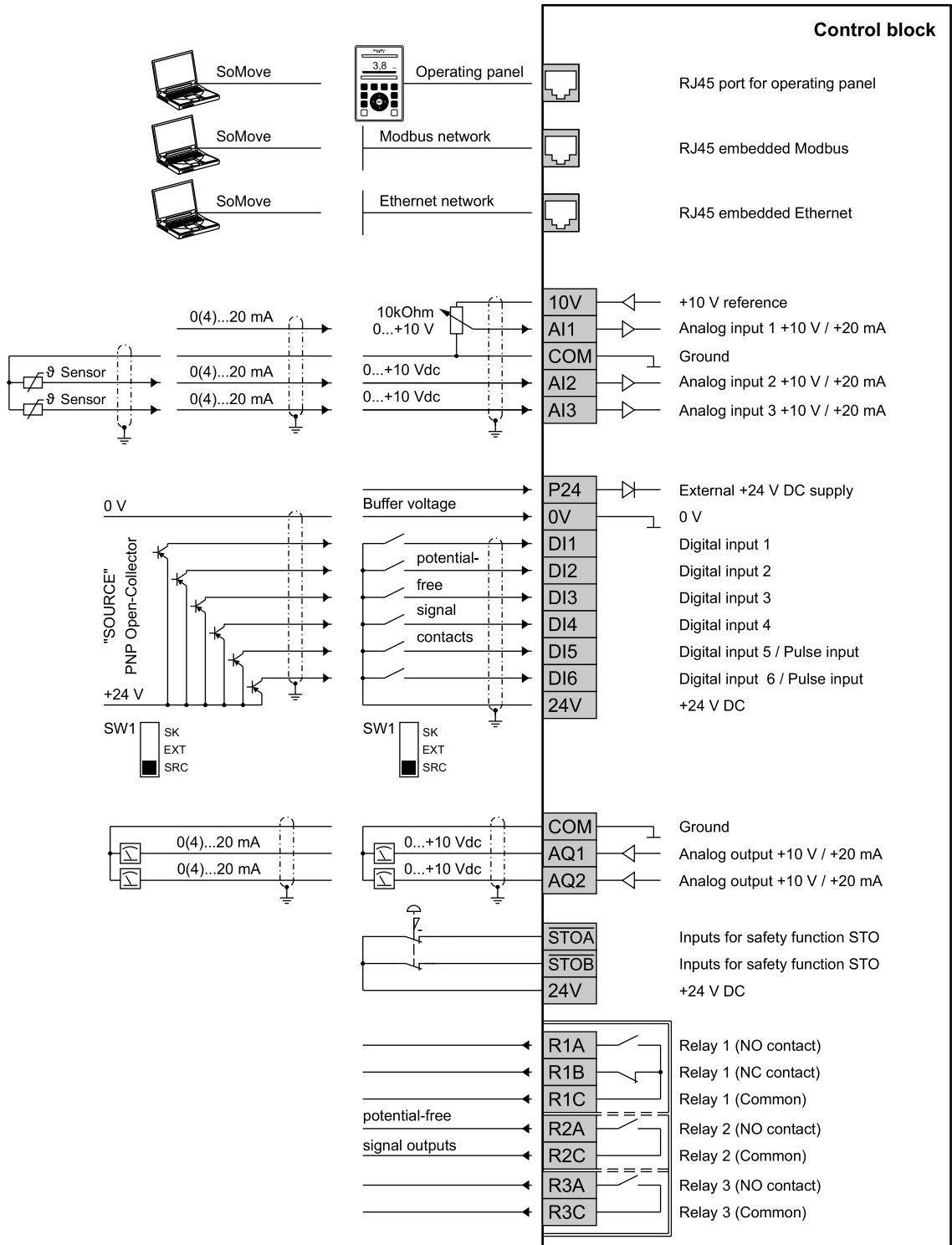

Specification of the Control Terminals

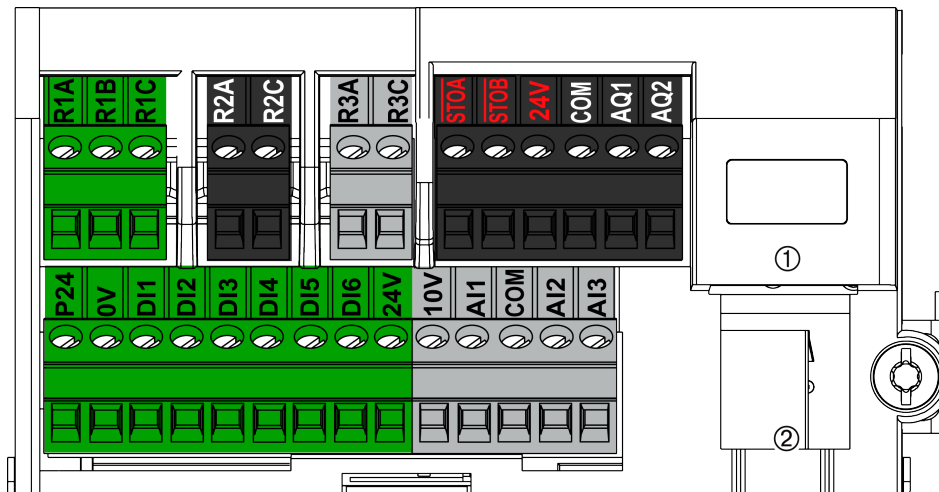

Screw terminals

Maximum cable cross section for all terminals:

- 1.5 mm² (AWG 16), 0.25 Nm (2.2 lbf.in)

Minimum cable cross section:

- For relay terminals 0.75 mm² (AWG 18)
- For all other terminals 0.5 mm² (AWG 20)

Strip length: 10 mm (0.39 in.)

Maximum cable length:

- AI●, AQ●, DI●, DQ●: 50 m (164 ft) shielded
- STOA, STOB: 30 m (98 ft) unshielded

Terminal	Description	I/O Type	Electrical characteristics
R1A	NO contact of relay R1	O	Output Relay 1 <ul style="list-style-type: none"> • Minimum switching capacity: 5 mA for 24 Vdc • Maximum switching current on resistive load: 3 A for 250 Vac (OVC II) and 30 Vdc • Maximum switching current on inductive load ($\cos \phi \geq 0.4$ and $L/R \leq 7$ ms): 2 A for 250 Vac (OVC II) and 30 Vdc. Inductive load must be equipped with a voltage surge limitation device according to ac or dc operation with total energy dissipation greater than the inductive energy stored in the load. Refer to sections Output Relay with Inductive AC Loads , page 107 and Output Relay with Inductive DC Loads , page 108. • Refresh time: 5 ms \pm 0.5 ms • Service life: 100,000 operations at maximum switching current
R1B	NC contact of relay R1	O	
R1C	Common point contact of relay R1	O	
R2A	NO contact of relay R2	O	Output Relay 2 <ul style="list-style-type: none"> • Minimum switching capacity: 5 mA for 24 Vdc • Maximum switching current on resistive load: 5 A for 250 Vac (OVC II) and 3A for 30 Vdc • Maximum switching current on inductive load ($\cos \phi \geq 0.4$ and $L/R \leq 7$ ms): 2 A for 250 Vac (OVCII) and 30 Vdc. Inductive load must be equipped with a voltage surge limitation device according to ac or dc operation with total energy dissipation greater than the inductive energy stored in the load. Refer to sections Output Relay with Inductive AC Loads , page 107 and Output Relay with Inductive DC Loads , page 108 • Refresh time: 5 ms \pm 0.5 ms • Service life: <ul style="list-style-type: none"> ◦ 100,000 operations at maximum switching current ◦ 1,000,000 operations at 0.5 A
R2C	Common point contact of relay R2	O	

Terminal	Description	I/O Type	Electrical characteristics
R3A	NO contact of relay R3	O	Output Relay 3 <ul style="list-style-type: none"> Minimum switching capacity: 5 mA for 24 Vdc Maximum switching current on resistive load: 5 A for 250 Vac (OVCII) and 3A for 30 Vdc Maximum switching current on inductive load ($\cos \phi \geq 0.4$ and $L/R \leq 7$ ms): 2 A for 250 Vac (OVCII) and 30 Vdc. Inductive load must be equipped with a voltage surge limitation device according to AC or DC operation with total energy dissipation greater than the inductive energy stored in the load. Refer to sections Output Relay with Inductive AC Loads , page 107 and Output Relay with Inductive DC Loads , page 108 Refresh time: 5 ms \pm 0.5 ms Service life: <ul style="list-style-type: none"> 100,000 operations at maximum switching current 1,000,000 operations at 0.5 A
R3C	Common point contact of relay R3	O	
<u>STOA</u> , STOB	STO inputs	I	Safety Function STO Inputs Refer to the Embedded Safety Function Manual (EAV64334) available on www.se.com
24V	Output power supply for digital inputs and safety function STO inputs	O	Use only PELV standard power supply unit. <ul style="list-style-type: none"> +24 Vdc Tolerance: minimum 20.4 Vdc, maximum 27 Vdc Current: maximum 200 mA for both 24 Vdc terminals Terminal protected against overload and short-circuit In Sink Ext position, this supply is powered by external PLC supply
COM	Analog I/O common	I/O	0 V for Analog outputs
AQ1	Analog output	O	AQ: Analog output software-configurable for voltage or current <ul style="list-style-type: none"> Voltage analog output 0...10 Vdc, minimum. Minimum load impedance 470 Ω, Current analog output X-Y mA by programming X and Y from 0...20 mA, maximum load impedance 500 Ω Sampling time: 10 ms + 1 ms maximum Resolution 10 bits Accuracy: ± 1 % for a temperature variation of 60 °C (108 °F) Linearity ± 0.2 %
AQ2	Analog output	O	
P24	External input supply	I	External input supply +24 Vdc <ul style="list-style-type: none"> Tolerance: minimum 19 Vdc, maximum 30 Vdc Current: maximum 0.8 A
0V	0 V	I/O	0 V for P24
DI1-DI6	Digital inputs	I	6 programmable logic inputs 24 Vdc, comply with IEC/EN 61131-2 logic type 1 <ul style="list-style-type: none"> Positive logic (Source): State 0 if ≤ 5 Vdc or logic input not wired, state 1 if ≥ 11 Vdc Negative logic (Sink): State 0 if ≥ 16 Vdc or logic input not wired, state 1 if ≤ 10 Vdc Impedance 3.5 kΩ Maximum voltage: 30 Vdc Sampling time: 2 ms + 0.5 ms maximum Multiple assignment makes it possible to configure several functions on one input (example: DI1 assigned to forward and preset speed 2, DI3 assigned to reverse and preset speed 3).
DI5-DI6	Pulse inputs	I	Programmable Pulse input <ul style="list-style-type: none"> Comply with level 1 PLC, IEC 65A-68 standard State 0 if < 0.6 Vdc, state 1 if > 2.5 Vdc Pulse counter 0...30 kHz Frequency range: 0...30 kHz Cyclic ratio: 50 % \pm 10 % Maximum input voltage 30 Vdc, < 10 mA Sampling time: 5 ms + 1 ms maximum

Terminal	Description	I/O Type	Electrical characteristics
10V	Output supply for Analog input	O	Internal supply for the analog inputs <ul style="list-style-type: none"> • 10.5 Vdc • Tolerance $\pm 5\%$ • Current: maximum 10 mA • Short circuit protected
AI1-AI2-AI3	Analog inputs	I	Software-configurable V/A : voltage or current analog input <ul style="list-style-type: none"> • Voltage analog input 0...10 Vdc, impedance 30 kΩ, • Current analog input X-Y mA by programming X and Y from 0...20 mA, with impedance 250 Ω • Sampling time: 5 ms + 1 ms maximum • Resolution 12 bits • Accuracy: $\pm 0.6\%$ for a temperature variation of 60 °C (108 °F) • Linearity $\pm 0.15\%$ of maximum value
COM	Analog I/O common	I/O	0 V for Analog inputs
AI2-AI3	Sensor inputs	I	Software-configurable PT100/PT1000 or KTY84 or PTC or Water level sensor <ul style="list-style-type: none"> • PT100 <ul style="list-style-type: none"> ◦ 1 thermal sensor or 3 thermal sensors mounted in series (configurable by software) ◦ Thermal sensor current: 5 mA ◦ Range -20...200 °C (-4...392 °F) ◦ Accuracy ± 4 °C (7.2 °F) for a temperature variation of 60 °C (140 °F) • PT1000 <ul style="list-style-type: none"> ◦ 1 thermal sensor or 3 thermal sensors mounted in series (configurable by software) ◦ Thermal sensor current: 1 mA ◦ Range -20...200 °C (-4...392 °F) ◦ Accuracy ± 4 °C (7.2 °F) for a temperature variation of 60 °C (140 °F) • PTC <ul style="list-style-type: none"> ◦ 1 thermal sensor or 3 thermal sensors or 6 thermal sensors mounted in series ◦ Thermal sensor current: 1 mA ◦ Nominal value: < 1.5 kΩ ◦ Overheat trigger threshold : 2.9 kΩ \pm 0.2kΩ ◦ Overheat reset threshold : 1.575 kΩ \pm 75Ω ◦ Low impedance detection threshold : 50 Ω -10 Ω / +20 Ω ◦ Open circuit threshold : 100 kΩ \pm 10kΩ • KTY84 <ul style="list-style-type: none"> ◦ 1 thermal sensor ◦ Thermal sensor current: 1 mA ◦ Range -20...200 °C (-4...392 °F) ◦ Accuracy ± 4 °C (7.2 °F) for a temperature variation of 60 °C (140 °F) • Water Level Sensor <ul style="list-style-type: none"> ◦ Sensitivity: 0...1 MΩ, adjustable by software ◦ Water level sensor current: 0.3 mA...1 mA maximum ◦ Adjustable delay: 0...10 s

DANGER

HAZARD OF ELECTRIC SHOCK, EXPLOSION OR ARC FLASH

- Verify that the temperature sensors in the motor meet the PELV requirements.
- Verify that the motor encoder meets the PELV requirements.
- Verify that any other equipment connected via signal cables meets the PELV requirements.

Failure to follow these instructions will result in death or serious injury.

Signal interference can cause unexpected responses of the device and of other equipment in the vicinity of the device.

▲ WARNING

SIGNAL AND EQUIPMENT INTERFERENCE

- Install the wiring in accordance with the EMC requirements described in this document.
- Verify compliance with the EMC requirements described in this document.
- Verify compliance with all EMC regulations and requirements applicable in the country in which the product is to be operated and with all EMC regulations and requirements applicable at the installation site.

Failure to follow these instructions can result in death, serious injury, or equipment damage.

Relay Contacts Wiring

Output Relay with Inductive AC Loads

General

The AC voltage source must be of overvoltage category II (OVC II) according to IEC 61800-5-1.

If it is not the case, an isolation transformer must be used.

Contactors with AC Coil

If controlled by a relay, a resistor-capacitor (RC) circuit must be connected in parallel to the coil of the contactor as shown on the diagram below:

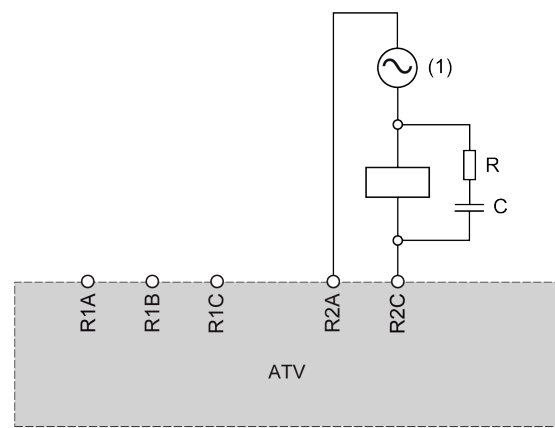

(1) AC 250 Vac maximum.

Schneider Electric AC contactors have a dedicated area on the housing to plug easily the RC device. Refer to the Motor control and protection components catalog MKTED210011EN available on se.com to find the RC device to be associated with the contactor used.

Example: With a 48 Vac source, contactors LC1D09E7 or LC1DT20E7 have to be used with LAD4RCE voltage suppression device.

Other Inductive AC Loads

For other inductive AC loads:

- Use an auxiliary contactor connected on the product to control the load.
Example: with a 48 Vac source, auxiliary contactors CAD32E7 or CAD50E7 with LAD4RCE voltage suppression device.
- When using a third party inductive AC load, request the supplier to provide information on the voltage suppression device, in order to avoid overvoltage above 375 V during relay opening.

Output Relay with Inductive DC loads

Contactors with DC Coil

If controlled by a relay, a bidirectional transient voltage suppression (TVS) diode, also called transil, must be connected in parallel to the coil of the contactor as shown on the diagram below:

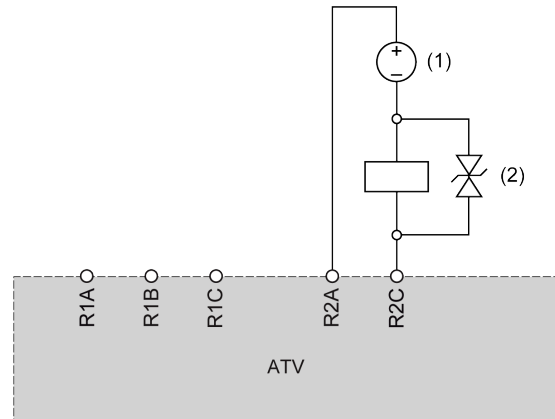

(1) DC 30 Vdc maximum.

(2) TVS diode

Schneider Electric contactors with DC coil include the TVS diode. No additional device is required.

Refer to the Motor control and protection components catalog MKTED210011EN available on se.com for more information.

Other Inductive DC Loads

Other inductive DC loads without embedded TVS diode must use one of the following voltage suppression device:

- A bidirectional TVS device as shown on the diagram above, defined by:
 - TVS break-down voltage greater than 35 Vdc,
 - TVS clamping voltage V(TVS) less than 50 Vdc
 - TVS peak power dissipation greater than load rated current, $I(\text{load}) \times V(\text{TVS})$.

Example: with $I(\text{load}) = 0.9 \text{ A}$ and $V(\text{TVS}) = 50 \text{ Vdc}$, TVS peak power must be greater than 45 W

- TVS average power dissipation greater than the value calculated by the following $0.5 \times I(\text{load}) \times V(\text{TVS}) \times \text{load time constant} \times \text{number of operation per second}$.

Example: with $I(\text{load}) = 0.9 \text{ A}$ and $V(\text{TVS}) = 50 \text{ Vdc}$, load time constant = 40 ms (load inductance divided by load resistance) and 1 operation every 3 s, the TVS average power dissipation must be greater than $0.5 \times 0.9 \times 50 \times 0.04 \times 0.33 = 0.3 \text{ W}$.

- A fly-back diode as shown in the diagram below:

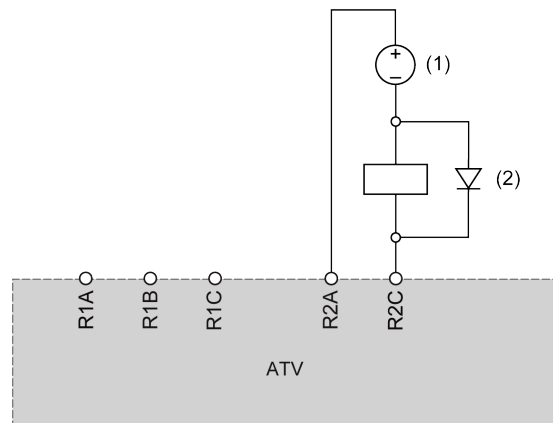

(1) DC 30 Vdc maxi.

(2) Flyback diode

The diode is a polarized device. The fly-back diode must be defined by:

- a reverse voltage greater than 100 Vdc,
- a rated current greater than two times the load rated current,
- a thermal resistance: junction to ambient temperature (in K/W) less than $90 / (1.1 \times I(\text{load}))$ to operate at maximum 60°C (140°F) ambient temperature.

Example: with $I(\text{load}) = 1.5 \text{ A}$, select a 100 V, 3 A rated current diode with a thermal resistance from junction to ambient less than $90 / (1.1 \times 1.5) = 54.5 \text{ K/W}$.

Using a flyback diode, the relay opening time will be longer than with a TVS diode.

NOTE: Use diodes with leads for easy wiring and keep at least 1 cm (0.39 in.) of leads on each side of the case of the diode for a correct cooling.

Digital Inputs Wiring Depending on Sink / Source Switch Configuration

About the Switch

⚠ WARNING

UNANTICIPATED EQUIPMENT OPERATION

- If the device is set to **SK** or **EXT**, do not connect the **0 V** terminal to ground or to protective ground.
- Verify that accidental grounding of digital inputs configured for sink logic, caused, for example, by damage to the signal cables, cannot occur.
- Follow all applicable standards and directives such as NFPA 79 and EN 60204 for proper control circuit grounding practices.

Failure to follow these instructions can result in death, serious injury, or equipment damage.

The switch is used to adapt the operation of the logic inputs to the technology of the programmable controller outputs. To access the switch, follow the Access to control Terminals procedure of the ATV600 or ATV900 Installation manual.

The switch is located below the control terminals at the control block, page 101.

- Set the switch to Source (factory setting) if using PLC outputs with PNP transistors.
- Set the switch to Ext if using PLC outputs with NPN transistors.

Wiring With Use of the Output Power Supply for the Digital Inputs

Switch set to **SRC** (Source) position

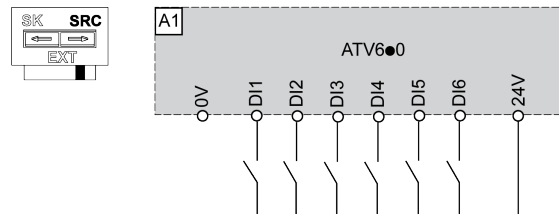

Switch set to **SK** (Sink) position

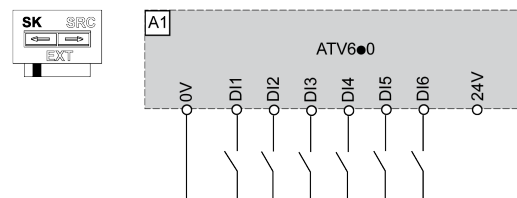

Wiring With Use of an External Power Supply for the Digital Inputs

⚠ ⚠ DANGER

ELECTRIC SHOCK CAUSED BY INCORRECT POWER SUPPLY UNIT

The +24 Vdc supply voltage is connected with many exposed signal connections in the drive system.

- Use a power supply unit that meets the PELV (Protective Extra Low Voltage) requirements.

Failure to follow these instructions will result in death or serious injury.

Switch set to **EXT** (Sink External) position **without functional isolation** on digital inputs

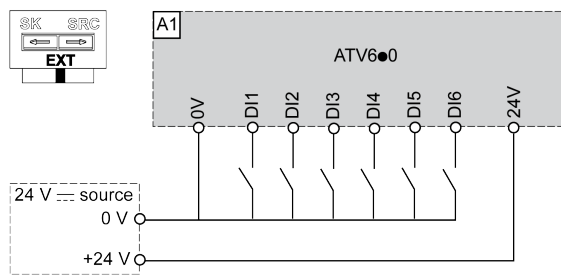

Switch set to **SRC** (Source) position

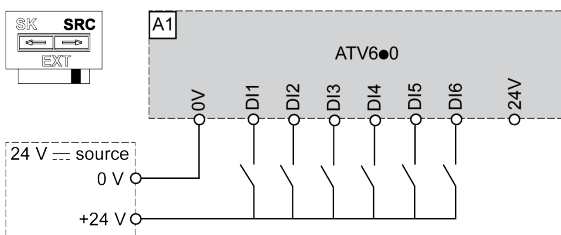

Option "Logic and Analog I/O Card"

What's in This Chapter

Control terminals at the expansion card	113
Specification of the Control Terminals	114

Control terminals at the expansion card

Option to expand the control inputs and control outputs of the control block. The expansion card contains two analog inputs, six digital inputs and two digital outputs.

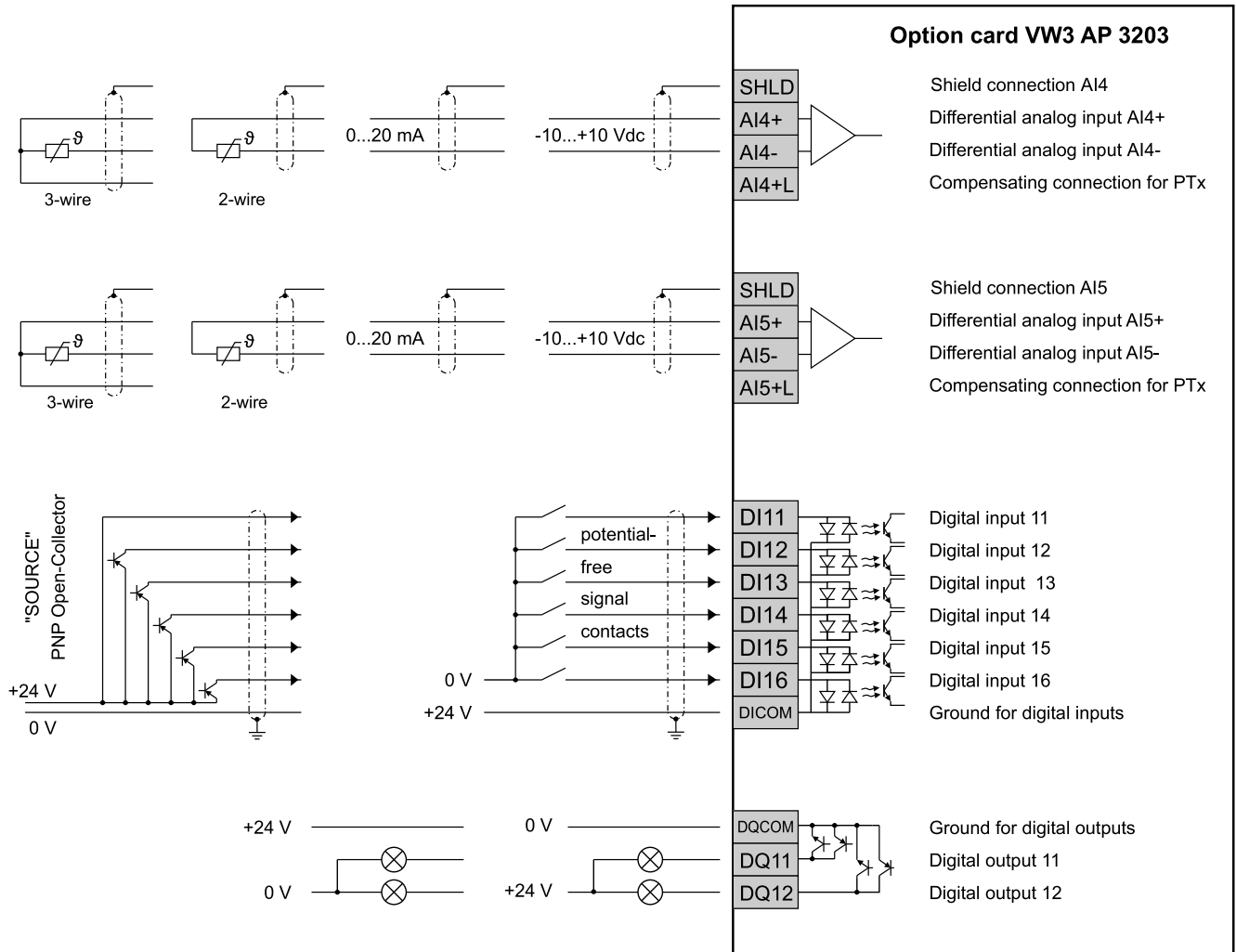

Specification of the Control Terminals

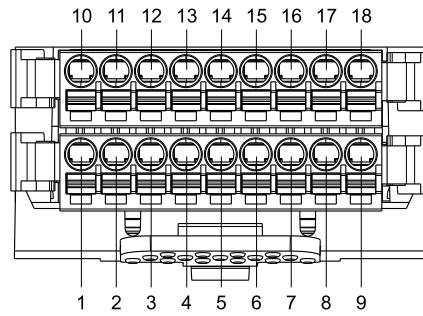

Spring terminals

Max. cable cross section: 1 mm² (AWG 16)

Strip length: 10 mm

Max. cable length AI●, AQ●, DI●, DQ●: 50 m (164 ft) shielded

Pin	Terminal	Description	Specification
1	SHLD	Shield connection for AI4	<p>You can select between voltage, current, Pt100, Pt1000, KTY84 and PTC measurement by software configuration.</p> <p>Differential voltage at the input circuit:</p> <ul style="list-style-type: none"> • Range: -10 V DC...+10 V DC • Impedance: 20 kΩ • Resolution: 11 bits + 1 sign bit • Accuracy: ±0.6 % for a temperature variation of 60 °C • Linearity ±0.15 % of maximum value <p>Current measurements:</p> <ul style="list-style-type: none"> • Range: freely programmable from 0...20 mA • Impedance: 250 Ω • Resolution: 12 bits • Accuracy: ±0.6 % for a temperature variation of 60 °C • Linearity ±0.15 % of maximum value • Sampling period: 1 ms <p>PTx measurement: Pt100, Pt1000, PTC or KTY84 configurable by software</p> <ul style="list-style-type: none"> • Pt100 <ul style="list-style-type: none"> ◦ 1 or 3 temperature sensors in series per analog input (configurable by software) ◦ Temperature sensor current: max. 7.5 mA ◦ Range -20...200 °C ◦ Accuracy: ±3°C for a temperature variation of 60 °C • Pt1000, KTY84 <ul style="list-style-type: none"> ◦ 1 (Pt1000, KTY84) or 3 (Pt1000) temperature sensors in series per analog input (configurable by software) ◦ Temperature sensor current: max. 1 mA ◦ Range -20...200 °C ◦ Accuracy: ±3 °C for a temperature variation of 60 °C • PTC <ul style="list-style-type: none"> ◦ 3 or 6 temperature sensors in series ◦ Temperature sensor current: max. 1 mA ◦ Nominal value: < 1.5 kΩ ◦ Overheat trigger threshold: 3 kΩ ◦ Overheat reset threshold: 1.8 kΩ ◦ Short-circuit detection threshold < 50 Ω ◦ Wire break detection: > 100 kΩ
2	AI4+	Differential analog input 4 Depending on software configuration: <ul style="list-style-type: none"> • Measurement of differential voltage • PTx measurement • 0...20 mA measurement • Reference potential AI4- for AI4+ 	
3	AI4-		
4	AI4+L	Compensating connection for one temperature sensor Pt100, Pt1000 or KTY84 in 3-wire-design	
5	SHLD	Shield connection for AI5	
6	AI5+	Differential analog input 5 Depending on software configuration: <ul style="list-style-type: none"> • Measurement of differential voltage • PTx measurement • 0...20 mA measurement • Reference potential AI5- for AI5+ 	
7	AI5-		
8	AI5+L	Compensating connection for one temperature sensor Pt100, Pt1000 or KTY84 in 3-wire-design	
9	DQ12	Digital output 12	

Pin	Terminal	Description	Specification
10	DICOM	Reference potential for the digital inputs	The 24 V DC digital inputs DI are galvanically isolated via optocoupler and comply with the standard IEC/EN 61131-2. <ul style="list-style-type: none"> • Logic type selected by DICOM wiring • Positive logic (Source): state 0 when ≤ 5 V DC, state 1 when ≥ 11 V DC • Negative logic (Sink): state 0 when ≥ 16 V DC, state 1 when ≤ 10 V DC • Maximum voltage: ≤ 30 V DC • Input current (typically): 2.5 mA • Sampling period: 1 ms
11	DI11	Digital input 11	
12	DI12	Digital input 12	
13	DI13	Digital input 13	
14	DI14	Digital input 14	
15	DI15	Digital input 15	
16	DI16	Digital input 16	
17	DQCOM	Reference potential for the digital outputs	The 24 V DC digital outputs DQ comply with the standard IEC/EN 61131-2. <ul style="list-style-type: none"> • Logic type selected by DQCOM wiring • Output voltage: ≤ 30 V DC • Switching capability: ≤ 100 mA • Voltage drop at 100 mA load: ≤ 3 V DC • Response time: 1 ms
18	DQ11	Digital output 11	

 DANGER

HAZARD OF ELECTRIC SHOCK, EXPLOSION OR ARC FLASH

- Verify that the temperature sensors in the motor meet the PELV requirements.
- Verify that the motor encoder meets the PELV requirements.
- Verify that any other equipment connected via signal cables meets the PELV requirements.

Failure to follow these instructions will result in death or serious injury.

Signal interference can cause unexpected responses of the device and of other equipment in the vicinity of the device.

 WARNING

SIGNAL AND EQUIPMENT INTERFERENCE

- Install the wiring in accordance with the EMC requirements described in this document.
- Verify compliance with the EMC requirements described in this document.
- Verify compliance with all EMC regulations and requirements applicable in the country in which the product is to be operated and with all EMC regulations and requirements applicable at the installation site.

Failure to follow these instructions can result in death, serious injury, or equipment damage.

Option "Relay Output Card"

What's in This Chapter

Control terminals at the expansion card	117
Specification of the Control Terminals of the "Relay Output Card"	117

Control terminals at the expansion card

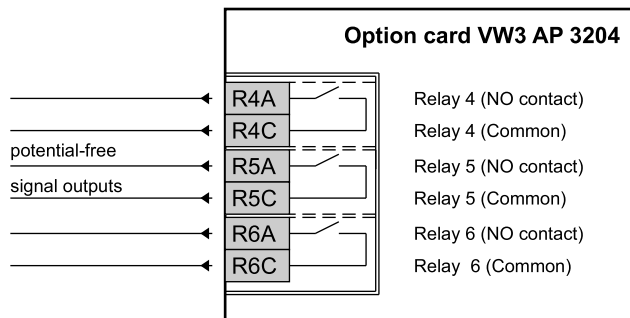

Specification of the Control Terminals of the "Relay Output Card"

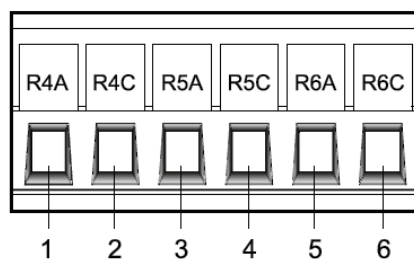

Spring terminals

- Max. cable cross section: 1.5 mm² (AWG 16)
- Maximum tightening torque: 0.5 Nm (4.4 lb.in)
- Minimum cable cross section: 0.75 mm² (AWG 18)
- Strip length: 10 mm

Pin	Terminal	Description	Specification
1	R4A	N. O. contact	Programmable relay outputs R4, R5 and R6: <ul style="list-style-type: none"> • Minimum switching capacity: 5 mA for 24 Vdc • Maximum switching capacity on resistive load: 5 A for 250 Vac (OVC II) and 30 Vdc • Maximum switching capacity on inductive load: 2 A for 250 Vac (OVC II) and 30 Vdc Inductive load must be equipped with a voltage surge suppression device according to AC or DC operation with total energy dissipation greater than the inductive energy stored in the load. Refer to sections Output Relay with Inductive AC Loads, page 107 and Output Relay with Inductive DC loads, page 108. • Refresh time according to the relay output of the drive in which the relay output card is installed. • Service life: <ul style="list-style-type: none"> ◦ 70,000 switching cycles at 5 A and resistive load ◦ 100,000 switching cycles at 4 A and resistive load ◦ 300,000 switching cycles at 2 A and resistive load ◦ 700,000 switching cycles at 0.5 A and resistive load
2	R4C		
3	R5A	N. O. contact	
4	R5C		
5	R6A	N. O. contact	
6	R6C		

Option Terminals

What's in This Chapter

Control Terminals at the Option Terminals	119
Specification of the Option control terminals	120

Control Terminals at the Option Terminals

The option terminals X200 and X205 are built-in. They are designed as pluggable terminals.

Spring terminals pluggable

Max. cable cross section: 2.5 mm² [AWG 12]

Min. cable cross section: 0.25 mm² [AWG 26]

Strip length: 10 mm

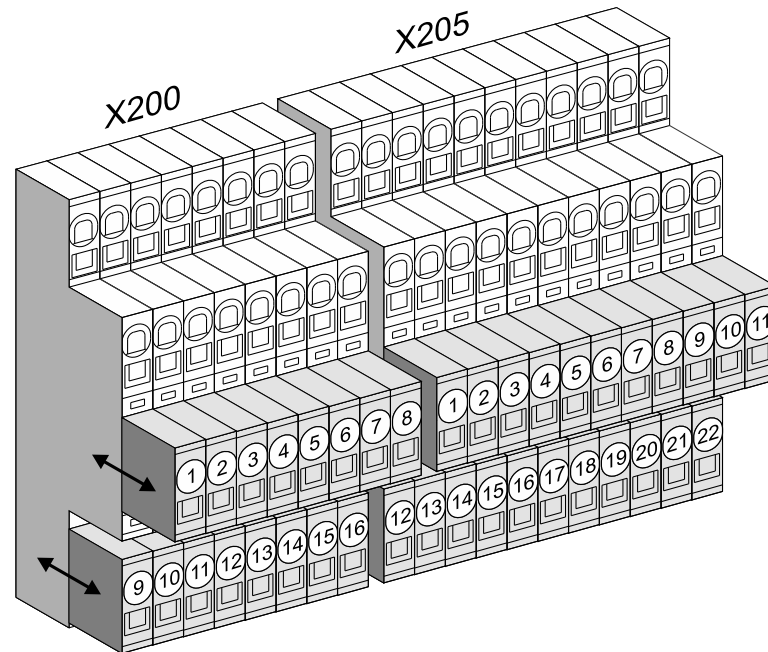

Specification of the Option control terminals

As shown in the following illustration, there are following connections available for the customer depending on the chosen options.

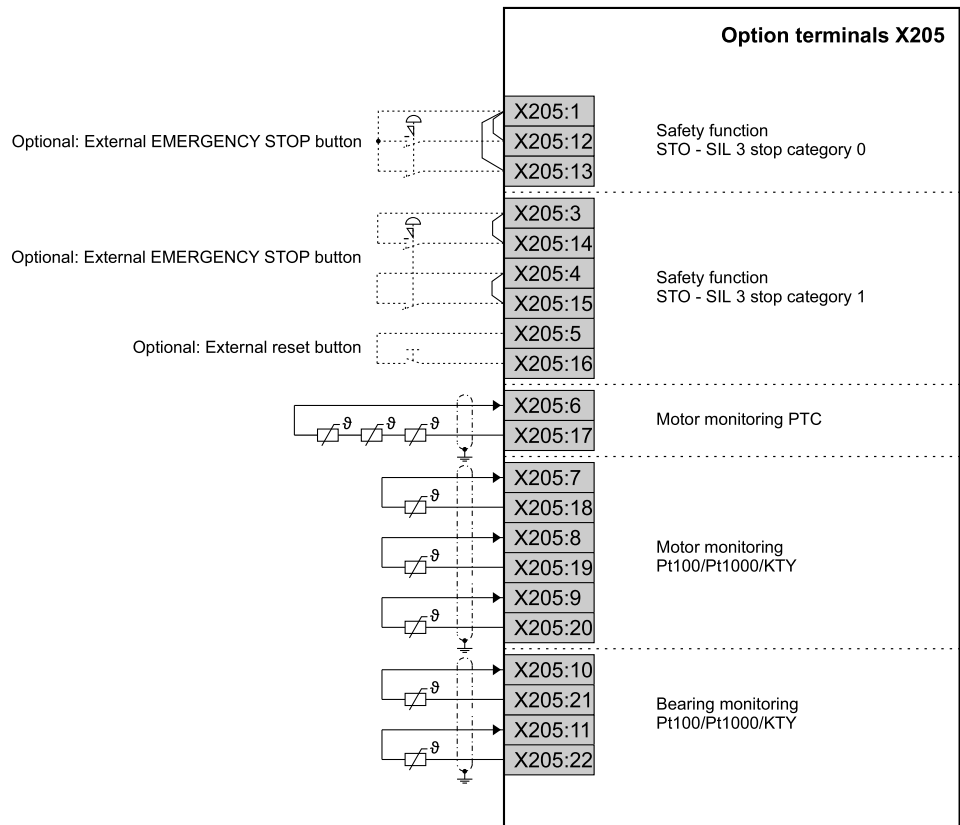
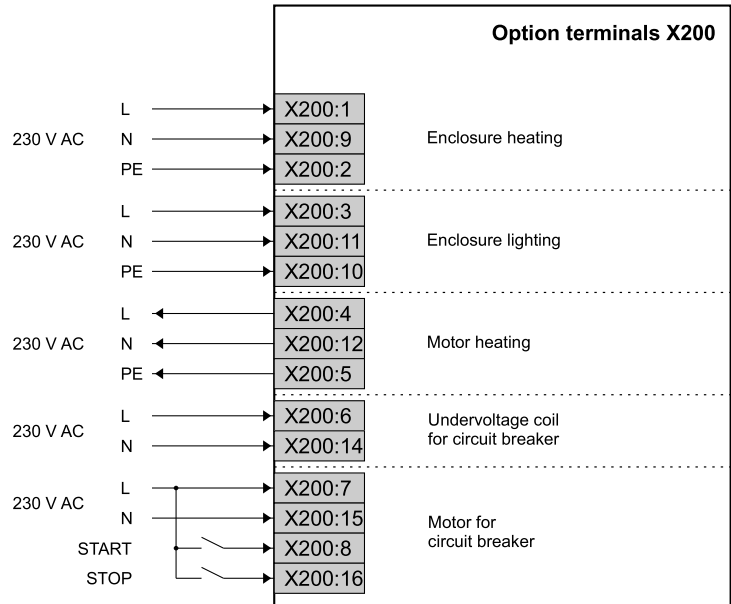

Customizations

What's in This Part

Enclosure Options	122
Control Options	127
I/O Expansion Cards	129
Communication Cards	131
Functional Safety	134
Display Options	136
Motor Options	138
Mains Supply	142
EcoStruxure Asset Advisor	145
Documentation / Packaging	147

Enclosure Options

What's in This Chapter

General Information.....	123
Increased Protection Degree IP54	123
Enclosure Plinth for Basic Device	124
Connection Enclosure Cable from Top	124
Connection Enclosure Cable from Bottom	124
Enclosure Lighting.....	125
Enclosure Heating	125
Modified Wiring Colors.....	126

General Information

During manufacturing of the Altivar Process Drive Systems already all customizations are considered. In addition, parameter adjustments are carried out and permanently stored as factory setting, if required.

This chapter contains customizations, which we have already predefined as a result of our many years of experience in order to cover the essential requirements of our customers. But in many cases a unique system solution is necessary due to the variety of applications and requirements.

Your Drive Systems Tendering Team is looking forward to your specific request.

Increased Protection Degree IP54

For operation with rough ambient conditions the enclosure can be designed in protection degree IP54.

So when the doors are closed the Altivar Process Drive System is protected against:

- Touching live electrical parts
- Harmful dust accumulation inside
- Penetration of spray water from all directions

Typically, IP54 enclosure units are installed production halls and manufacturing sites, where heavy dirt accumulation is expected.

Our solution contains a clearly specified and tested cooling system with a separate cooling air channel which provides highest reliability.

Via this separated cooling air channel about 90 % of the heat losses are exhausted. The interior of the enclosure is cooled via fans in the enclosure door.

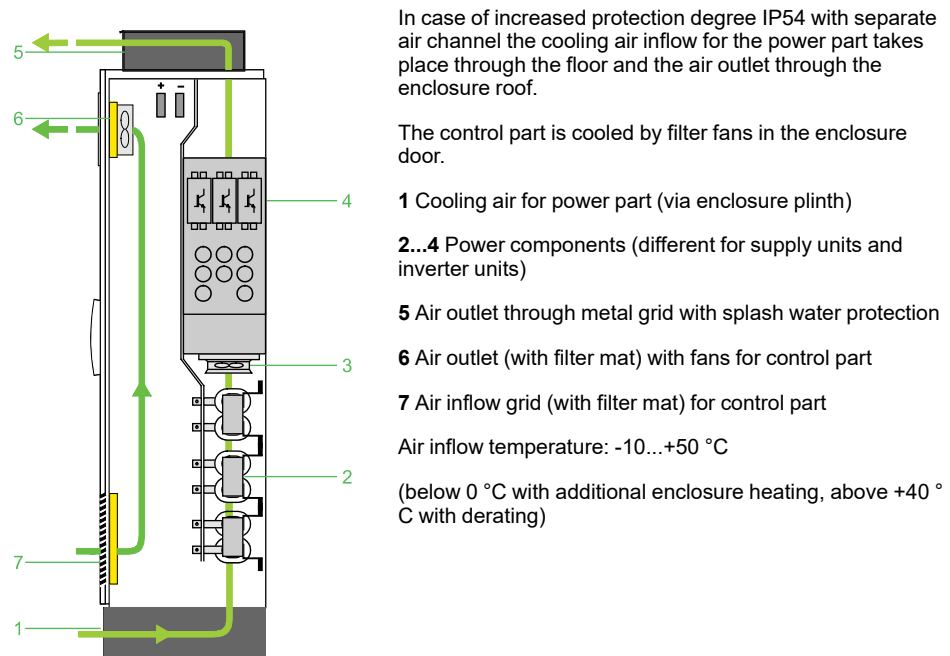

NOTE: The additional enclosure plinth increases the enclosure by 200 mm to a total height of 2350 mm.

Enclosure Plinth for Basic Device

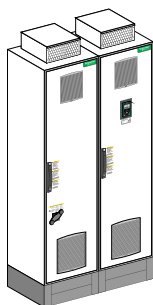

For adapting to the local conditions or for better protection of the enclosure against wet soil, the enclosure can be raised with a plinth (color: RAL 7022) by 200 mm.

So the enclosure height is increased to a total height of 2350 mm.

NOTE: At the customization "Increased protection degree IP54" the enclosure is already equipped with an enclosure plinth as standard.

Connection Enclosure Cable from Top

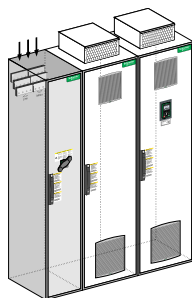

This separate connection enclosure makes it possible to insert and connect the mains cables and motor cables from the top of the enclosure.

The separated connecting enclosure contains all power terminals and the mains disconnection (e.g. main switch), which makes a voltage disconnection of the basic device during maintenance possible.

Furthermore, the connecting enclosure provides enough space for additional customizations.

NOTE: The additional connecting enclosure increases the total width of the enclosure.

Connection Enclosure Cable from Bottom

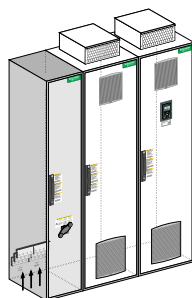

This separate connection enclosure makes it possible to insert and connect the mains cables and motor cables from the bottom of the enclosure.

The separated connecting enclosure contains all power terminals and the mains disconnection (e.g. main switch), which makes a voltage disconnection of the basic device during maintenance possible.

Furthermore, the connecting enclosure provides enough space for additional customizations.

NOTE: The additional connecting enclosure increases the total width of the enclosure.

Enclosure Lighting

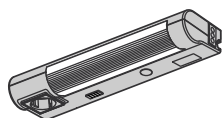

In order to make maintenance easier, the enclosure can be equipped with a lighting, which is switched on when opening the enclosure door.

The lighting is externally supplied and so it is also available at switched off mains supply. Furthermore, a power socket according to VDE standard (230 V / 50 Hz, 2 A) is located on the lighting to operate smaller consumers on-site.

- NOTE:** The additional power supply at terminals X200 has to be provided by the user.
- Rated voltage: 230 V
 - Rated frequency: 50/60 Hz
 - Rated power: 500 VA

This option requires an additional external 230 V power supply with overvoltage category 1 or 2 (according to IEC/UL 61800-5-1) connected to terminals X200.

⚡ ⚠ DANGER

HAZARD OF ELECTRIC SHOCK

Verify that the external power supply complies with all national and local electrical code requirements.

Failure to follow these instructions will result in death or serious injury.

Enclosure Heating

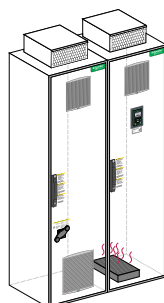

This customization is used to heat the enclosure in order to avoid frost and condensation at an ambient temperature up to -10°C. The enclosure heating is externally supplied, so the enclosure can be also heated when mains supply is switched off.

- NOTE:** The additional power supply at terminals X200 has to be provided by the user.
- Rated voltage: 230 V
 - Rated frequency: 50/60 Hz
 - Rated power: 400...800 VA

This option requires an additional external 230 V power supply with overvoltage category 1 or 2 (according to IEC/UL 61800-5-1) connected to terminals X200.

⚡ ⚠ DANGER

HAZARD OF ELECTRIC SHOCK

Verify that the external power supply complies with all national and local electrical code requirements.

Failure to follow these instructions will result in death or serious injury.

Modified Wiring Colors

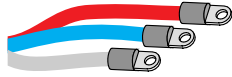

This option contains modified wiring colors as well as red, white and blue heat shrink tubes at the power cables.

Control Options

What's in This Chapter

Key Switch "local / remote"	128
Ethernet Port on Front Door	128

Key Switch "local / remote"



The key switch "local / remote" allows to switch between local operation (via the graphical operating panel) or remote control (terminals or bus). The switch can be only operated with a key and so it can be only switched by authorized personnel.

Ethernet Port on Front Door

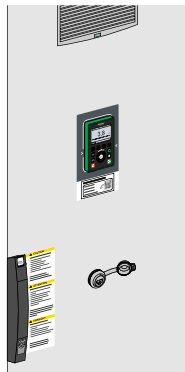

The Ethernet port in the enclosure door allows access to the frequency inverter without opening the enclosure door. The plug can be closed with a dust protection cap.

I/O Expansion Cards

What's in This Chapter

Expansion Card With Additional Inputs / Outputs	130
Expansion Card With Relay Outputs	130

Expansion Card With Additional Inputs / Outputs



Expansion card for additional analog and digital inputs and outputs (6 digital inputs, 2 digital outputs, 2 analog inputs)

You will find further information at chapter Option "Logic and Analog I/O Card", page 112.

Expansion Card With Relay Outputs

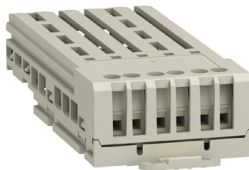

Expansion card with three additional relay outputs

You will find further information at chapter Option "Relay Output Card", page 116.

Communication Cards

What's in This Chapter

Communication Card Modbus TCP or EtherNet IP	132
Communication Card CANopen Daisy Chain	132
Communication Card CANopen SUB-D9	132
Communication Card CANopen With Spring Terminals	132
Communication Card DeviceNet.....	132
Communication Card Profibus DP	133
Communication Card PROFINET	133

You will find detailed information in the respective documentation. See listing under chapter Related Documents, page 16.

Communication Card Modbus TCP or EtherNet IP



Dual port option card for control of the inverter via Modbus TCP or EtherNet/IP

Communication Card CANopen Daisy Chain



Option card for control of the inverter via CANopen Daisy Chain

Communication Card CANopen SUB-D9



Option card for control of the inverter via CANopen with SUB-D port.

Communication Card CANopen With Spring Terminals

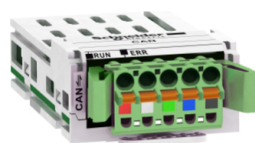

Option card for control of the inverter via CANopen with spring terminals

Communication Card DeviceNet

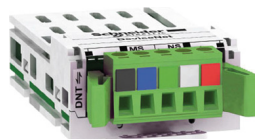

Option card for control of the inverter via DeviceNet

Communication Card Profibus DP

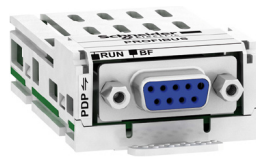

Option card for control of the inverter via Profibus DP V1

Communication Card PROFINET

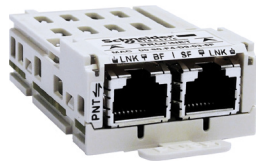

Option card for control of the inverter via PROFINET

Functional Safety

What's in This Chapter

Safe Torque Off (STO)	135
SIL 3 Stop Category 0 / Performance Level PL e	135
SIL 3 Stop Category 1 / Performance Level PL e	135

Safe Torque Off (STO)

The Altivar Process is equipped with the safety function "Safe Torque Off STO" according to ISO 13849-1, IEC/EN 61508, IEC/EN 60204-1, which helps to prevent any unintended start-up of the motor.

- Inputs $\overline{\text{STOA}}$ and $\overline{\text{STOB}}$ directly at the control terminals of the control block. This function fulfills, when correctly wired, the machine standard ISO 13849-1, Performance level PL e, the IEC/EN 61508 Safety integrity level SIL 3 standard for functional safety and the power drive system standard IEC/EN 61800-5-2.
- Customization SIL3, stop category 0 / PL e
The triggering of the safety function leads to a coast down of the drive and helps to prevent an unintended restart.
- Customization SIL3, stop category 1 / PL e
The triggering of this function starts a controlled deceleration, shuts down the drive after the set time and helps to prevent an unintended restart.

NOTE: You will find further information in the Safety Function Manual (EAV64334).

SIL 3 Stop Category 0 / Performance Level PL e

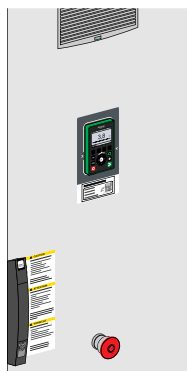

Via an EMERGENCY STOP button in the enclosure door or further implemented, external monitoring equipment, the torque at the motor can be switched off according SIL 3 stop category 0 / performance level PL e.

The triggering of the safety function leads to a coast down of the drive and helps to prevent an unintended restart.

SIL 3 Stop Category 1 / Performance Level PL e

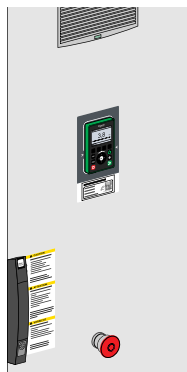

Via an EMERGENCY STOP button in the enclosure door or further implemented, external monitoring equipment, the torque at the motor can be switched off according SIL 3 stop category 1 / performance level PL e.

The triggering of this function starts a controlled deceleration, shuts down the drive after the set time and helps to prevent an unintended restart.

Display Options

What's in This Chapter

Front Display Module (FDM)	137
Indicator Lamps on Front Door	137

Front Display Module (FDM)

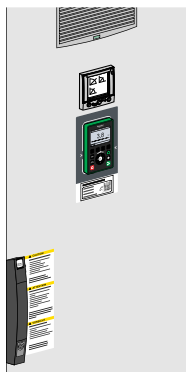

A display element mounted in the enclosure door enables clear indication of real-time values like:

- Indication of mains currents (3x)
- Mains voltages (3x phase voltages, 3x phase-to-phase voltages)
- Mains power

These values can be indicated graphically or digital.

The display element is provided with backlight for increased readability.

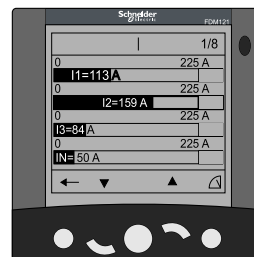

Indicator Lamps on Front Door

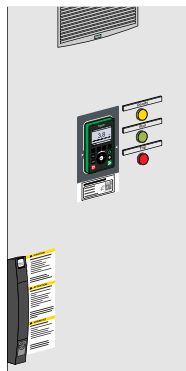

For quick, optical diagnostics of the actual operating state from a greater distance, the enclosure can be equipped with indicator lamps.

The lamps show following operating states:

Operating state	Indicator lamp	Labeling
Ready	Yellow	READY
Operation	Green	RUN
Detected fault	Red	TRIP

Motor Options

What's in This Chapter

Motor Monitoring PTC.....	139
Motor Monitoring PTC with ATEX Certificate.....	139
Motor monitoring Pt100/Pt1000/KTY.....	139
Bearing Monitoring Pt100/Pt1000/KTY.....	140
dv/dt Filter Choke 150 m.....	140
dv/dt Filter Choke 300 m.....	140
Motor Heating.....	141

Motor Monitoring PTC

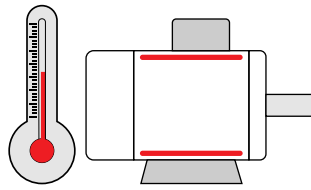

If the motor is equipped with integrated thermistor sensors to help to protect against thermal overload, they can be directly connected to a thermistor relay inside the Altivar Process Drive System.

If the frequency inverter detects an overtemperature at the motor, the drive stops the motor and generates an error message at the display. This operating state is also forwarded to the status relays and to the fieldbus.

NOTE: When protective separation of the thermistor sensors in the motor cannot be guaranteed or in case of long motor cables, this option is highly recommended.

Motor Monitoring PTC with ATEX Certificate

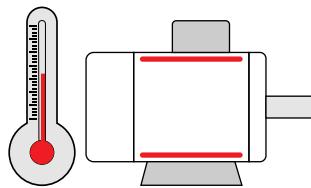

The motor monitoring PTC with ATEX certificate is used to monitor the thermistor sensors of motors which are installed in hazardous area (explosive atmosphere).

If the frequency inverter detects the overtemperature at the motor, the drive stops the motor and generates an error message at the display. This operating state is also forwarded to the status relays and to the fieldbus. The monitoring relay additionally triggers a safe shut-down of the drive.

This equipment has been designed to operate outside of any hazardous location. Only install this equipment in zones known to be free of a hazardous atmosphere.

⚠ DANGER
POTENTIAL FOR EXPLOSION
Install and use this equipment in non-hazardous locations only.
Failure to follow these instructions will result in death or serious injury.

Motor monitoring Pt100/Pt1000/KTY

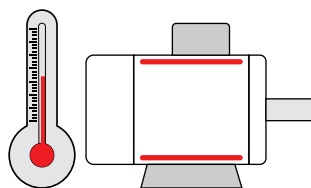

If the motor is equipped with integrated temperature sensors (Pt100, Pt1000, KTY 83/84) in the winding to help to protect against thermal overload, they can be directly connected to the relay inside the Altivar Process Drive System.

If the set temperature at the motor is exceeded, a warning message is generated. When the temperature is further rising over a set value, the drive is stopped and an error message is generated. The operating states are also forwarded to the status relays and to the fieldbus.

NOTE: When protective separation of the thermistor sensors in the motor cannot be guaranteed or in case of long motor cables, this option is highly recommended.

Bearing Monitoring Pt100/Pt1000/KTY

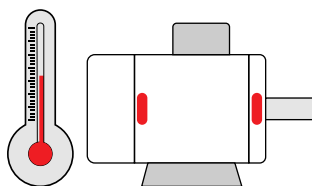

If the motor is equipped with integrated temperature sensors (Pt100, Pt1000, KTY 83/84) in the bearings to help to protect against thermal overload, they can be directly connected to the relay inside the Altivar Process Drive System.

If the set temperature at the motor is exceeded, a warning message is generated. When the temperature is further rising over a set value, the drive is stopped and an error message is generated. The operating states are also forwarded to the status relays and to the fieldbus.

NOTE: When protective separation of the thermistor sensors in the motor cannot be guaranteed or in case of long motor cables, this option is highly recommended.

dv/dt Filter Choke 150 m

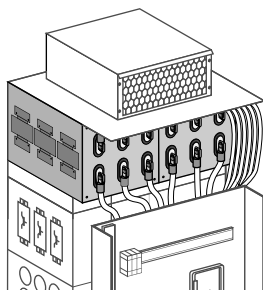

The use of the customization dv/dt filter choke 150 m has significant advantages concerning the operation of the drive:

- Decrease of the dv/dt and peak voltage load of the motor
- Prevention of common mode bearing currents in the motor – especially important at high power
- Great reduction of the influences to other cables – important if the separate laying of motor cables is not possible
- In case of long motor cables up to 150 m shielded or up to 250 m unshielded
- dv/dt filter choke 150 m can be installed without enlarged enclosure width.

NOTE: You will find further information about long motor cables under chapter Length of Motor Cables, page 89.

dv/dt Filter Choke 300 m

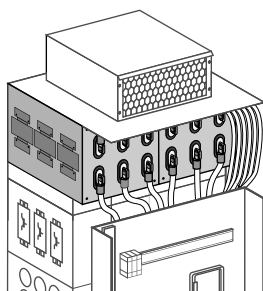

The use of the customization dv/dt filter choke 300 m has significant advantages concerning the operation of the drive:

- Decrease of the dv/dt and peak voltage load of the motor
- Prevention of common mode bearing currents in the motor – especially important at high power
- Great reduction of the influences to other cables – important if the separate laying of motor cables is not ensured
- In case of long motor cables up to 300 m shielded or up to 500 m unshielded
- dv/dt filter choke 300 m can be installed without enlarged enclosure width.

NOTE: You will find further information about long motor cables under chapter Length of Motor Cables, page 89.

Motor Heating

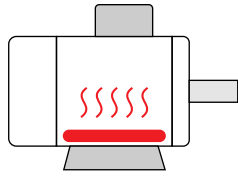

The motor standstill heating is used to avoid condensate and frost damages at standstill of the motors in cold environment. It is activated when the motor is shut down.

Mains Supply

What's in This Chapter

Circuit Breaker	143
Undervoltage Coil for Circuit Breaker 230 V	143
Motor for Circuit Breaker 230 V	144

Circuit Breaker

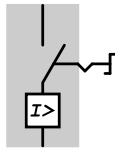

The circuit breaker is used for mains disconnection instead of the main switch. It is operated by a handle in the enclosure door.

The circuit breaker can be optionally equipped with an undervoltage coil and motor.

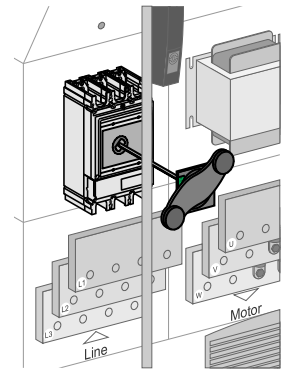

Undervoltage Coil for Circuit Breaker 230 V

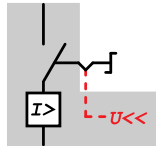

When there is no voltage at the undervoltage coil, the circuit breaker switches off.

The undervoltage coil is built into the circuit breaker and is wired to the option terminals.

Specification of the control terminals

X200: 6/14 External control voltage
220...240 V AC 50/60 Hz

- NOTE:**
- Only when control voltage is applied, the circuit breaker can be switched on manually.
 - You will find further information about the topic wiring under chapter Option Terminals, page 118.

Motor for Circuit Breaker 230 V

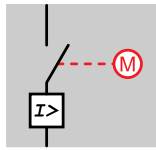

Remote control of the circuit breaker via control commands is possible by means of this motor drive. The motor drive is built into the circuit breaker and is wired to the option terminals.

Specification of the control terminals

X200: 7/15	External control voltage 220...240 V AC 50/60 Hz
X200: 8	Start request
X200: 16	Stop request

Specification of the motor drive:

External control circuit voltage:	<ul style="list-style-type: none"> • 230 V AC \pm 5% 50/60 Hz
Reaction time:	<ul style="list-style-type: none"> • < 80 ms when closing • < 600 ms when opening
Power input:	<ul style="list-style-type: none"> • \leq 500 VA when closing • \leq 500 VA when opening

- NOTE:**
- At this customization no handle for the circuit breaker is possible.
 - You will find further information about the topic wiring under chapter Option Terminals, page 118.
 - You will find further information about the topic switching rate under chapter Switching Rate, page 37.

EcoStruxure Asset Advisor

EcoStruxure Asset Advisor is part and fully integrated in the unique Schneider Electric EcoStruxure platform and helps to reduce risks for personnel and increase operational continuity of your installation.

Asset Advisor is integrated in the “Apps, Analytics & Services” layer and provide cloud based monitoring and smart alarming services.

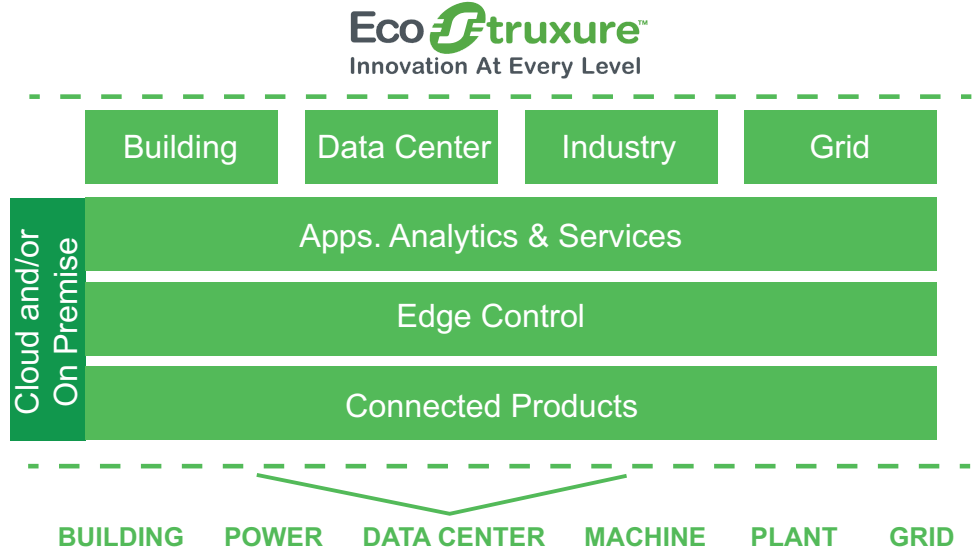

Altivar Process Drives belong to the “Connected Products” layer of EcoStruxure and provide solutions to optimize the operation and maintenance of your drives installation.

Utilizing newest technologies seamless integrated into Schneider Electric Managed Services and IoT architecture, you benefit from predictive maintenance effectiveness.

It allows you to manage maintenance tasks on your assets based on condition based monitoring and predictive analytics. All thanks to the combination of smart connected device technologies and powerful cloud-based risk prediction capabilities. An Altivar Process with EcoStruxure Asset Advisor transforms data into insight and help to run your operations more efficiently and safer, with more availability, and increased profits.

In summary the Asset Advisor functionality can be described in 3 steps:

Continuous health monitoring

The operator gets a health monitoring view of its assets and conditions of usage (extensive drive information and essential data from peripheral equipment). These assets act as super-sensors providing relevant data and KPIs.

Risk evaluation

The operator knows where and what risks are on the installation. Predictive analytics constantly evaluates the level and criticality of risk by looking at an asset, the process duty cycle, and the condition of usage. This enables the ability to predict, in advance, a potential failure or dysfunction of the installation.

Risk mitigation

The operator receives notification of the necessary maintenance task required at the right time to secure the asset and production at minimal cost, mitigating the risks of downtime.



Documentation / Packaging

What's in This Chapter

Safety Labels in Local Language	148
Seaworthy Packaging	148

Safety Labels in Local Language

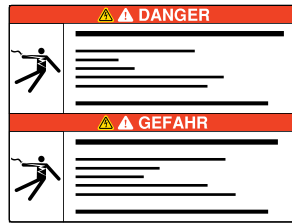

All Altivar Process Drive Systems are delivered with safety labels in English and French. Optionally the devices can be also ordered with labels in the local language.

Seaworthy Packaging

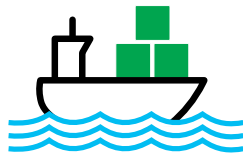

This option contains a seaworthy packaging for transport by ship. The packaging complies with the HPE packaging guidelines (federal association for wooden packages, pallets and export packaging in Germany).

Schneider Electric
35 rue Joseph Monier
92500 Rueil Malmaison
France

+ 33 (0) 1 41 29 70 00

www.se.com

As standards, specifications, and design change from time to time, please ask for confirmation of the information given in this publication.

© 2016 – 2025 Schneider Electric. All rights reserved.

NHA37113.03