

Altivar Process

Drive Systems

Installation manual

NHA37119.04
03/2022



Legal Information

The Schneider Electric brand and any trademarks of Schneider Electric SE and its subsidiaries referred to in this guide are the property of Schneider Electric SE or its subsidiaries. All other brands may be trademarks of their respective owners.

This guide and its content are protected under applicable copyright laws and furnished for informational use only. No part of this guide may be reproduced or transmitted in any form or by any means (electronic, mechanical, photocopying, recording, or otherwise), for any purpose, without the prior written permission of Schneider Electric.

Schneider Electric does not grant any right or license for commercial use of the guide or its content, except for a non-exclusive and personal license to consult it on an "as is" basis. Schneider Electric products and equipment should be installed, operated, serviced, and maintained only by qualified personnel.

As standards, specifications, and designs change from time to time, information contained in this guide may be subject to change without notice.

To the extent permitted by applicable law, no responsibility or liability is assumed by Schneider Electric and its subsidiaries for any errors or omissions in the informational content of this material or consequences arising out of or resulting from the use of the information contained herein.

Table of Contents

Safety Information	5
About the Book.....	13
Handling	19
Checking the Scope of Delivery	20
Handling Instructions.....	21
Mechanical Installation.....	22
General Mounting Instruction	23
Installation of the Enclosure	24
Wiring.....	27
Wiring Instructions	28
Protective Grounding	29
EMC Grounding.....	29
Operation on an IT or Corner Grounded System	30
Disconnecting the Built-In EMC Filter	30
Shield of the Motor Cable	36
Connection of Power Cables.....	37
Connection of the Control Cables	42
Liquid Cooling ATV•L0	50
General Specifications	51
Commissioning	54
Proceeding.....	55
Maintenance	60
Scheduled Servicing	61
Decommissioning	62
Additional Support	62
Index	63

Safety Information

NOTICE

Read these instructions carefully, and look at the equipment to become familiar with the device before trying to install, operate, service, or maintain it. The following special messages may appear throughout this documentation or on the equipment to warn of potential hazards or to call attention to information that clarifies or simplifies a procedure.



The addition of this symbol to a “Danger” or “Warning” safety label indicates that an electrical hazard exists which will result in personal injury if the instructions are not followed.



This is the safety alert symbol. It is used to alert you to potential personal injury hazards. Obey all safety messages that follow this symbol to avoid possible injury or death.

DANGER

DANGER indicates a hazardous situation which, if not avoided, **will result in** death or serious injury.

WARNING

WARNING indicates a hazardous situation which, if not avoided, **could result in** death or serious injury.

CAUTION

CAUTION indicates a hazardous situation which, if not avoided, **could result in** minor or moderate injury.

NOTICE

NOTICE is used to address practices not related to physical injury.

PLEASE NOTE

Electrical equipment should be installed, operated, serviced, and maintained only by qualified personnel. No responsibility is assumed by Schneider Electric for any consequences arising out of the use of this material.

A qualified person is one who has skills and knowledge related to the construction and operation of electrical equipment and its installation, and has received safety training to recognize and avoid the hazards involved.

Qualification Of Personnel

Only appropriately trained persons who are familiar with and understand the contents of this manual and all other pertinent product documentation are authorized to work on and with this product. In addition, these persons must have received safety training to recognize and avoid hazards involved. These persons must have sufficient technical training, knowledge and experience and be able to foresee and detect potential hazards that may be caused by using the product, by changing the settings and by the mechanical, electrical and electronic equipment of the entire system in which the product is used. All persons working on and with the product must be fully familiar with all applicable standards, directives, and accident prevention regulations when performing such work.

Intended Use

This product is a drive for three-phase synchronous, asynchronous motors and intended for industrial use according to this manual.

The product may only be used in compliance with all applicable safety standard and local regulations and directives, the specified requirements and the technical data. The product must be installed outside the hazardous ATEX zone. Prior to using the product, you must perform a risk assessment in view of the planned application. Based on the results, the appropriate safety measures must be implemented. Since the product is used as a component in an entire system, you must ensure the safety of persons by means of the design of this entire system (for example, machine design). Any use other than the use explicitly permitted is prohibited and can result in hazards.

Product Related Information

Read and understand these instructions before performing any procedure with this drive.

DANGER

HAZARD OF ELECTRIC SHOCK, EXPLOSION OR ARC FLASH

- Only appropriately trained persons who are familiar with and fully understand the contents of the present manual and all other pertinent product documentation and who have received all necessary training to recognize and avoid hazards involved are authorized to work on and with this drive system.
- Installation, adjustment, repair and maintenance must be performed by qualified personnel.
- Verify compliance with all local and national electrical code requirements as well as all other applicable regulations with respect to grounding of all equipment.
- Only use properly rated, electrically insulated tools and measuring equipment.
- Do not touch unshielded components or terminals with voltage present.
- Prior to performing any type of work on the drive system, block the motor shaft to prevent rotation.
- Insulate both ends of unused conductors of the motor cable.
- Do not short across the DC bus terminals or the DC bus capacitors or the braking resistor terminals.

Failure to follow these instructions will result in death or serious injury.

⚠️⚠️ DANGER**HAZARD OF ELECTRIC SHOCK, EXPLOSION, OR ARC FLASH**

Before performing work on the drive system:

- Disconnect all power, including external control power that may be present. Take into account that the circuit breaker or main switch does not de-energize all circuits.
- Place a "Do Not Turn On" label on all power switches related to the drive system.
- Lock all power switches in the open position.
- Wait 15 minutes to allow the DC bus capacitors to discharge.
- Verify the absence of voltage. (1)

Before applying voltage to the drive system:

- Verify that the work has been completed and that the entire installation cannot cause hazards.
- If the mains input terminals and the motor output terminals have been grounded and short-circuited, remove the ground and the short circuits on the mains input terminals and the motor output terminals.
- Verify proper grounding of all equipment.
- Verify that all protective equipment such as covers, doors, grids is installed and/or closed.

Failure to follow these instructions will result in death or serious injury.

(1) Refer to Verifying the Absence of Voltage, page 11.

Damaged products or accessories may cause electric shock or unanticipated equipment operation.

⚠️⚠️ DANGER**ELECTRIC SHOCK OR UNANTICIPATED EQUIPMENT OPERATION**

Do not use damaged products or accessories.

Failure to follow these instructions will result in death or serious injury.

Contact your local Schneider Electric sales office if you detect any damage whatsoever.

This equipment has been designed to operate outside of any hazardous location. Only install this equipment in zones known to be free of a hazardous atmosphere.

⚠️ DANGER**POTENTIAL FOR EXPLOSION**

Install and use this equipment in non-hazardous locations only.

Failure to follow these instructions will result in death or serious injury.

Your application consists of a whole range of different interrelated mechanical, electrical, and electronic components, the drive being just one part of the application. The drive by itself is neither intended to nor capable of providing the entire functionality to meet all safety-related requirements that apply to your application. Depending on the application and the corresponding risk assessment to be conducted by you, a whole variety of additional equipment is required such as, but not limited to, external encoders, external brakes, external monitoring devices, guards, etc.

As a designer/manufacturer of machines, you must be familiar with and observe all standards that apply to your machine. You must conduct a risk assessment and determine the appropriate Performance Level (PL) and/or Safety Integrity Level (SIL) and design and build your machine in compliance with all applicable standards. In doing so, you must consider the interrelation of all components of the machine. In addition, you must provide instructions for use that enable the user of your machine to perform any type of work on and with the machine such as operation and maintenance in a safe manner.

The present document assumes that you are fully aware of all normative standards and requirements that apply to your application. Since the drive cannot provide all safety-related functionality for your entire application, you must ensure that the required Performance Level and/or Safety Integrity Level is reached by installing all necessary additional equipment.

⚠ WARNING
<p>INSUFFICIENT PERFORMANCE LEVEL/SAFETY INTEGRITY LEVEL AND/OR UNINTENDED EQUIPMENT OPERATION</p> <ul style="list-style-type: none"> • Conduct a risk assessment according to EN ISO 12100 and all other standards that apply to your application. • Use redundant components and/or control paths for all critical control functions identified in your risk assessment. • Implement all monitoring functions required to avoid any type of hazard identified in your risk assessment, for example, slipping or falling loads. • Verify that the service life of all individual components used in your application is sufficient for the intended service life of your overall application. • Perform extensive commissioning tests for all potential error situations to verify the effectiveness of the safety-related functions and monitoring functions implemented, for example, but not limited to, speed monitoring by means of encoders, short circuit monitoring for all connected equipment, correct operation of brakes and guards. • Perform extensive commissioning tests for all potential error situations to verify that the load can be brought to a safe stop under all conditions. <p>Failure to follow these instructions can result in death, serious injury, or equipment damage.</p>

A specific application note NHA80973 is available on hoisting machines and can be downloaded on se.com.

The products may perform unexpected movements because of incorrect wiring, incorrect settings, incorrect data or other errors.

⚠ WARNING
<p>UNANTICIPATED EQUIPMENT OPERATION</p> <ul style="list-style-type: none"> • Carefully install the wiring in accordance with the EMC requirements. • Do not operate the product with unknown or unsuitable settings or data. • Perform a comprehensive commissioning test. <p>Failure to follow these instructions can result in death, serious injury, or equipment damage.</p>

Power Drive Systems (PDS) can generate strong local electrical and magnetic fields. This can cause interference in electromagnetically sensitive devices.

▲ WARNING

ELECTROMAGNETIC FIELDS

- Keep persons with electronic medical implants, such as pacemakers, away from the equipment.
- Do not place electromagnetically sensitive devices in the vicinity of the equipment.

Failure to follow these instructions can result in death, serious injury, or equipment damage.

▲ WARNING

LOSS OF CONTROL

- The designer of any control scheme must consider the potential failure modes of control paths and, for critical control functions, provide a means to achieve a safe state during and after a path failure. Examples of critical control functions are emergency stop, overtravel stop, power outage and restart.
- Separate or redundant control paths must be provided for critical control functions.
- System control paths may include communication links. Consideration must be given to the implications of unanticipated transmission delays or failures of the link.
- Observe all accident prevention regulations and local safety guidelines (1).
- Each implementation of the product must be individually and thoroughly tested for proper operation before being placed into service.

Failure to follow these instructions can result in death, serious injury, or equipment damage.

(1) For USA: Additional information, refer to NEMA ICS 1.1 (latest edition), Safety Guidelines for the Application, Installation, and Maintenance of Solid State Control and to NEMA ICS 7.1 (latest edition), Safety Standards for Construction and Guide for Selection, Installation and Operation of Adjustable-Speed Drive Systems.

The temperature of the products described in this manual may exceed 100 °C (212 °F) during operation.

▲ WARNING

HOT SURFACES

- Ensure that any contact with hot surfaces is avoided.
- Do not allow flammable or heat-sensitive parts in the immediate vicinity of hot surfaces.
- Verify that the product has sufficiently cooled down before handling it.
- Verify that the heat dissipation is sufficient by performing a test run under maximum load conditions.

Failure to follow these instructions can result in death, serious injury, or equipment damage.

Fans may continue to run for a certain period of time even after power to the product has been disconnected.

▲ CAUTION

RUNNING FANS

Verify that fans have come to a complete standstill before handling them.

Failure to follow these instructions can result in injury or equipment damage.

NOTICE

DESTRUCTION DUE TO INCORRECT MAINS VOLTAGE

Before switching on and configuring the product, verify that it is approved for the mains voltage.

Failure to follow these instructions can result in equipment damage.

Verifying the Absence of Voltage

The DC bus voltage level is determined by measuring the voltage between the DC bus terminals PA/+ and PC/-.

DANGER

HAZARD OF ELECTRIC SHOCK, EXPLOSION, OR ARC FLASH

Before performing work on the drive system:

- Disconnect all power, including external control power that may be present. Take into account that the circuit breaker or main switch does not de-energize all circuits.
- Place a "Do Not Turn On" label on all power switches related to the drive system.
- Lock all power switches in the open position.
- Wait 15 minutes to allow the DC bus capacitors to discharge.
- Verify the absence of voltage. (1)

Before applying voltage to the drive system:

- Verify that the work has been completed and that the entire installation cannot cause hazards.
- If the mains input terminals and the motor output terminals have been grounded and short-circuited, remove the ground and the short circuits on the mains input terminals and the motor output terminals.
- Verify proper grounding of all equipment.
- Verify that all protective equipment such as covers, doors, grids is installed and/or closed.

Failure to follow these instructions will result in death or serious injury.

(1) Refer to Verifying the Absence of Voltage, page 11.

WARNING

INCORRECT MEASUREMENT VALUES

- Before using measuring equipment and tools, verify that the measuring equipment and tools are in proper condition.
- Calibrate and maintain all measuring equipment and tools according to the instructions of the manufacturers of the measuring equipment and tools.

Failure to follow these instructions can result in death, serious injury, or equipment damage.

Step	Action
1	Measure the voltage (in AC mode and DC mode) on the mains input terminals and the motor output terminals between the phases and between each phase to ground to verify that no hazardous voltage is present.
2	Measure the voltage on the DC bus between the DC bus terminals (PA/+ and PC/-) to verify that the voltage is less than 10 Vdc.
3	If there is still voltage present on the terminals or if the DC bus capacitors do not discharge properly, contact your local Schneider Electric representative. Do not repair or operate the product.
4	Verify that no other voltage is present in the drive system.
5	Ground and short-circuit the mains input terminals and the motor output terminals.

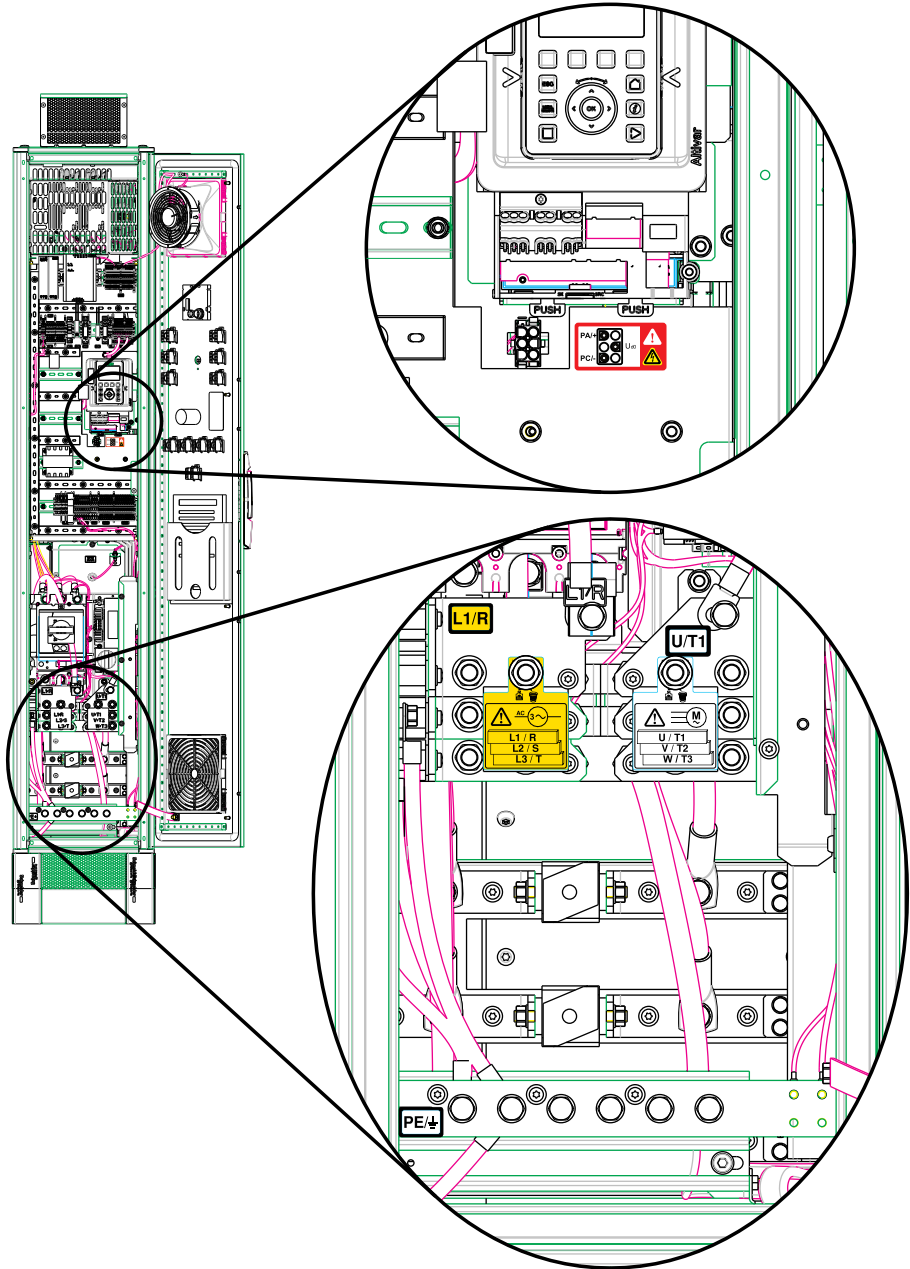

About the Book

Document Scope

Providing mechanical and electrical information about the Altivar Process Drive System and instructions about mounting, wiring, commissioning and maintenance.

Validity Note

Original instructions and information given in the present document have been written in English (before optional translation).

This documentation is valid for the Altivar Process Drive Systems.

The technical characteristics of the devices described in the present document also appear online. To access the information online, go to the Schneider Electric home page www.se.com/ww/en/download/.

The characteristics that are described in the present document should be the same as those characteristics that appear online. In line with our policy of constant improvement, we may revise content over time to improve clarity and accuracy. If you see a difference between the document and online information, use the online information as your reference.

Related Documents

Use your tablet or your PC to quickly access detailed and comprehensive information on all our products on www.se.com.

The internet site provides the information you need for products and solutions:

- The whole catalog for detailed characteristics and selection guides,
- The CAD files to help design your installation, available in over 20 different file formats,
- All software and firmware to maintain your installation up to date,
- A large quantity of White Papers, Environment documents, Application solutions, Specifications... to gain a better understanding of our electrical systems and equipment or automation,
- And finally all the User Guides related to your drive, listed below:

Title of Documentation	Catalog Number
Digital Catalog for Industrial Automation	Digit-Cat
Leaflet: Altivar Process customized drive solutions	998-19696726 (English)
Catalog: Altivar Process ATV600 variable speed drives	DIA2ED2140502EN (English), DIA2ED2140502FR (French)
Catalog: Variable speed drives Altivar Process ATV900	DIA2ED2150601EN (English), DIA2ED2150601FR (French)
ATV660 Handbook	NHA37110 (German), NHA37111 (English)
ATV680 Handbook	NHA37112 (German), NHA37113 (English)
ATV960 Handbook	NHA37114 (German), NHA37115 (English)
ATV980 Handbook	NHA37116 (German), NHA37117 (English)
ATV990 Handbook	NHA37143 (German), NHA37145 (English)
ATV630, ATV650 Installation Manual	EAV64301 (English), EAV64302 (French), EAV64306 (German), EAV64307 (Spanish), EAV64310 (Italian), EAV64317 (Chinese), EAV64301PT (Portuguese), EAV64301TR (Turkish)
ATV930, ATV950 Installation manual	NHA80932 (English), NHA80933 (French), NHA80934 (German), NHA80935 (Spanish), NHA80936 (Italian), NHA80937 (Chinese), NHA80932PT (Portuguese), NHA80932TR (Turkish)
ATV600F, ATV900F Installation Instruction sheet	NVE57369 (English)
Drive Systems – Installation manual	NHA37118 (German), NHA37119 (English), NHA37121 (French), NHA37122 (Spanish), NHA37123 (Italian), NHA37124 (Dutch), NHA37126 (Polish), NHA37127 (Portuguese), NHA37129 (Turkish), NHA37130 (Chinese)
ATV6●● Programming manual	EAV64318 (English), EAV64320 (French), EAV64321 (German), EAV64318PT (Portuguese), EAV64318RU (Russian), EAV64322 (Spanish), EAV64323 (Italian), EAV64324 (Chinese)
ATV6●● Modbus serial link manual (embedded)	EAV64325 (English)
ATV6●● Ethernet manual (embedded)	EAV64327 (English)
ATV6●● Ethernet IP - Modbus TCP manual (VW3A3720, 721)	EAV64328 (English)
ATV6●● BACnet MS/TP manual (VW3A3725)	QGH66984 (English)
ATV6●● PROFIBUS DP Manual (VW3A3607)	EAV64329 (English)
ATV6●● DeviceNet manual (VW3A3609)	EAV64330 (English)
ATV6●● PROFINET manual (VW3A3627)	EAV64331 (English)
ATV6●● CANopen manual (VW3A3608, 618, 628)	EAV64333 (English)
ATV6●● POWERLINK Manual (VW3A3619)	PHA99690 (English)
ATV6●● Communication parameters	EAV64332 (English)
ATV6●● Embedded safety function manual	EAV64334 (English)
ATV6●● & ATV9●● ATEX manual	NVE42416 (English)

Title of Documentation	Catalog Number
SoMove: FDT	SoMove_FDT (English, French, German, Spanish, Italian, Chinese)
Altivar Process ATV6●● DTM	ATV6xx_DTM_Library_EN (English), ATV6xx_DTM_Library_FR (French), ATV6xx_DTM_Library_DE (German), ATV6xx_DTM_Library_SP (Spanish), ATV6xx_DTM_Library_IT (Italian), ATV6xx_DTM_Library_CN (Chinese),
Application note: ATV600 Multi-drives booster control optimized	QGH36060 (English)
Application note: ATV600 Multi-masters booster control pressure feedback with cervice continuity	QGH36061 (English)
Application Note: ATV600 Multi-Drives Standard Level Control	QGH36059 (English)
Application note: ATV600 Multi-masters with optimized level control	EAV64367 (English)
Altivar Application Note for Hoisting	NHA80973 (English)
ATV9●● Programming manual	NHA80757 (English), NHA80758 (French), NHA80759 (German), NHA80760 (Spanish), NHA80761 (Italian), NHA80762 (Chinese)
ATV991, ATV992 Programming manual	QGH33275 (English)
ATV9●● Modbus serial link manual	NHA80939 (English)
ATV9●● Ethernet embedded manual	NHA80940 (English)
ATV9●● PROFIBUS DP manual (VW3A3607)	NHA80941 (English)
ATV9●● DeviceNet manual (VW3A3609)	NHA80942 (English)
ATV9●● PROFINET manual (VW3A3627)	NHA80943 (English)
ATV9●● CANopen manual (VW3A3608, 618, 628)	NHA80945 (English)
ATV9●● EtherCAT manual (VW3A3601)	NHA80946 (English)
ATV9●● POWERLINK manual (VW3A3619)	PHA99693 (English)
ATV9●● Communication parameters addresses	NHA80944 (English)
ATV9●● Embedded safety function manual	NHA80947 (English)
ATV6●● & ATV9●● ATEX manual	NVE42416 (English)
SoMove: FDT	SoMove_FDT (English, French, German, Spanish, Italian, Chinese)
Altivar Process ATV9●● DTM	ATV9xx_DTM_Library_EN (English), ATV9xx_DTM_Library_FR (French), ATV9xx_DTM_Library_DE (German), ATV9xx_DTM_Library_SP (Spanish), ATV9xx_DTM_Library_IT (Italian), ATV9xx_DTM_Library_CN (Chinese),
Recommended Cybersecurity Best Practices	CS-Best-Practices-2019-340 (English)

You can download these technical publications and other technical information from our website at www.se.com.

Green Premium™

Description

Information on the environmental impact of products, their resource efficiency, and end-of-life instructions.

Easy access to information: "Check Your Product"

Certificates and relevant product information available at the address:

www.se.com/green-premium

You can download RoHS and REACH compliance declarations, Product Environmental Profiles (PEP) and End-of-Life instructions (EoLi).



Terminology

The technical terms, terminology, and the corresponding descriptions in this manual normally use the terms or definitions in the relevant standards.

In the area of drive systems this includes, but is not limited to, terms such as **error**, **error message**, **failure**, **fault**, **fault reset**, **protection**, **safe state**, **safety function**, **warning**, **warning message**, and so on.

Among others, these standards include:

- IEC 61800 series: Adjustable speed electrical power drive systems
- IEC 61508 Ed.2 series: Functional safety of electrical/electronic/programmable electronic safety-related
- EN 954-1 Safety of machinery - safety-related parts of control systems
- ISO 13849-1 & 2 Safety of machinery - safety related parts of control systems
- IEC 61158 series: Industrial communication networks - Fieldbus specifications
- IEC 61784 series: Industrial communication networks - Profiles
- IEC 60204-1: Safety of machinery - Electrical equipment of machines – Part 1: General requirements

In addition, the term **zone of operation** is used in conjunction with the description of specific hazards, and is defined as it is for a **hazard zone** or **danger zone** in the EC Machinery Directive (2006/42/EC) and in ISO 12100-1.

Contact us

Select your country on www.se.com/contact.

Schneider Electric Industries SAS

Head Office

35, rue Joseph Monier

92500 Rueil-Malmaison

France

Handling

What's in This Chapter

Checking the Scope of Delivery	20
Handling Instructions	21

Checking the Scope of Delivery

Damaged products or accessories may cause electric shock or unanticipated equipment operation.

⚡ ⚠ DANGER

ELECTRIC SHOCK OR UNANTICIPATED EQUIPMENT OPERATION

Do not use damaged products or accessories.







Failure to follow these instructions will result in death or serious injury.

Contact your local Schneider Electric sales office if you detect any damage whatsoever.

Step	Action
1	Verify that the catalog number printed on the nameplate corresponds to the purchase order.
2	Before performing any installation work, inspect the product for visible damage.

Check whether the specification on the name plate complies with those of the order.

Example for a name plate:

Altivar Process		
ATV660C25Q4X1		
Power: ND 250kW / HD 200kW		
	Input	Output
U (V)	3AC 380...415 TN / TT	3AC 0...415
F (Hz)	50/60	0,1...500
I_{ND} (A)	432	477
I_{HD} (A)	353	370
I_{sc} (kA)	50 (100ms)	
Auxiliary supplies: (10 C 2 4V 0 ,8A) 1A C 230V 5A		Protection class: IP23
Drawing No.: 8AP1234		
Serial No.:	EL153612345678	NSC
    		
06/21 Made in Austria		
		
Schneider Electric Power Drives AT 1210 Vienna www.se.com/contact		Schneider Electric Industries SAS 35 Rue Joseph Monier FR-92500 Rueil Malmaison

- ← Product type
- ← Reference number
- ← Nominal power

- ← Serial number

Accessories and Options

Altivar Process Drive Systems can be ordered in different design variations and with numerous options to increase the functionality. A detailed description can be found in the respective Handbook on www.schneider-electric.com.

All options are already installed in the factory and considered in the documentation of the enclosure.

Handling Instructions

⚠ WARNING

INCORRECT HANDLING

- Follow all handling instructions provided in this manual and in all associated product documentation.
- Handle and store the product in its original packaging.
- Do not handle and store the product if the packaging is damaged or appears to be damaged.
- Take all measures required to avoid damage to the product and other hazards when handling or opening the packaging.

Failure to follow these instructions can result in death, serious injury, or equipment damage.

To help protect the product before installation, handle and store it in its packaging. Ensure that the specified ambient conditions are followed.

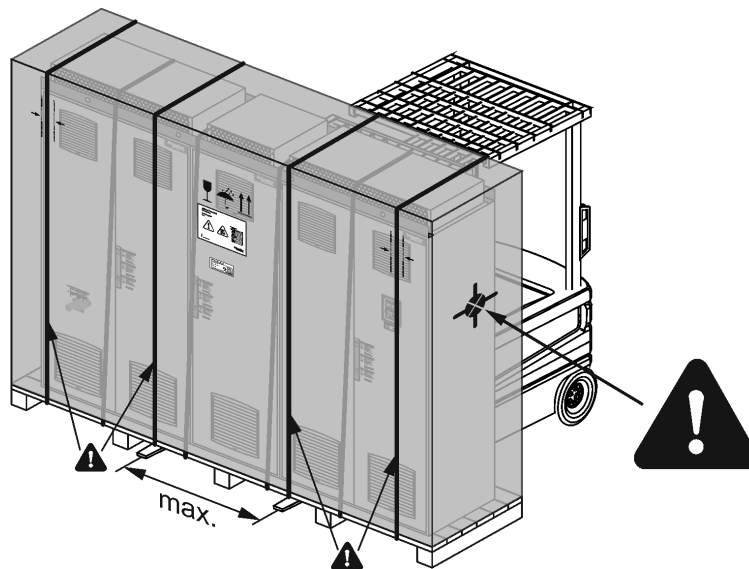

Verify that the ambient conditions for storage and transportation specified in the handbook are respected.

⚠ WARNING

TOPPLING

- Take into account the high center of gravity when handling the equipment.
- Only transport the equipment on the pallet using a suitable forklift.
- Do not remove the straps and the screws on the pallet before the equipment has been transported to the final installation position.

Failure to follow these instructions can result in death, serious injury, or equipment damage.

Mechanical Installation

What's in This Chapter

General Mounting Instruction	23
Installation of the Enclosure	24

General Mounting Instruction

The drives are qualified for vertical installation in electrical operating rooms as well as in the area of production facilities.

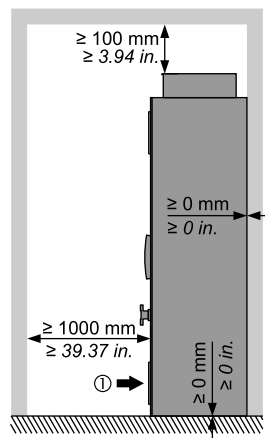

- Observe the specified minimum distances. Mounting the Drive Systems side by side or back to back is allowed.
 - Install the drive vertically on a non-combustible, solid and vibration-free ground.
 - Take care of compliance with the ambient conditions.
 - Take care that the air exchange is sufficient for dissipation of the lost heat during operation.
- ① Air inflow temperature: -10...+50 °C (14...122 °F) (below 0 °C (32 °F) with additional enclosure heating, above +40 °C (104 °F) with derating)

This equipment has been designed to operate outside of any hazardous location. Only install this equipment in zones known to be free of a hazardous atmosphere.

⚠ DANGER

POTENTIAL FOR EXPLOSION

Install and use this equipment in non-hazardous locations only.

Failure to follow these instructions will result in death or serious injury.

Installation of the Enclosure

The enclosures are delivered with handling lugs or lifting rails for optimum handling with a hoist.

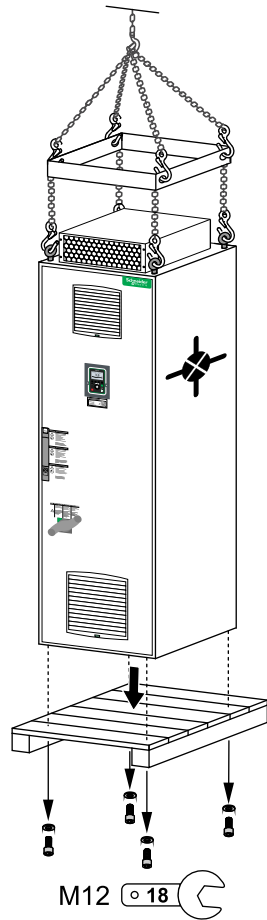

Mount the handling lugs, which are provided in a separate packaging.

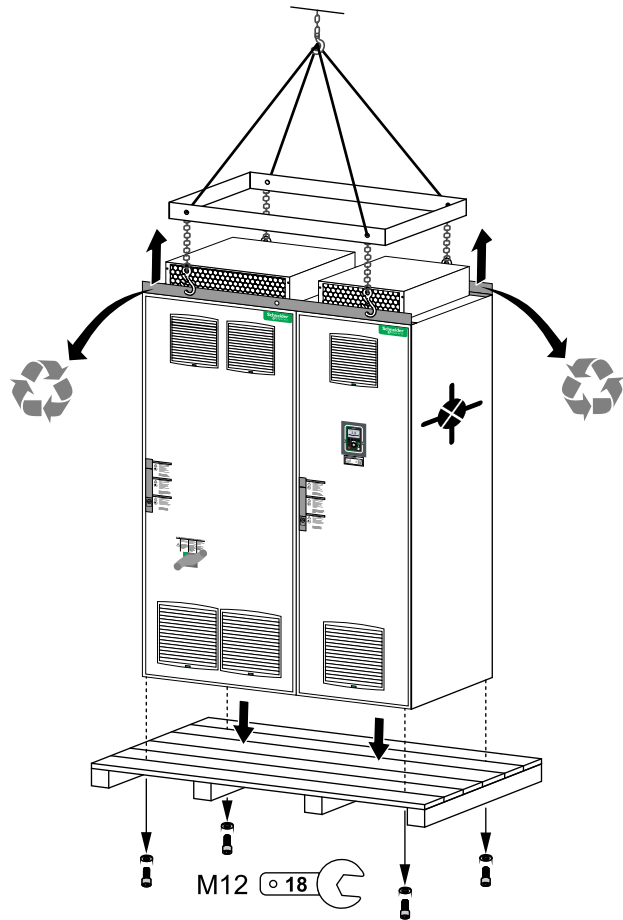

Remove the lifting rails after final placement. Then fix the roof using the screws (M12 x 22 / 27 Nm) and washers provided in a separate packaging.

▲ WARNING

TOPPLING

Fasten the equipment at the final installation position according to the instructions given in this document.

Failure to follow these instructions can result in death, serious injury, or equipment damage.

Fastening the Enclosure

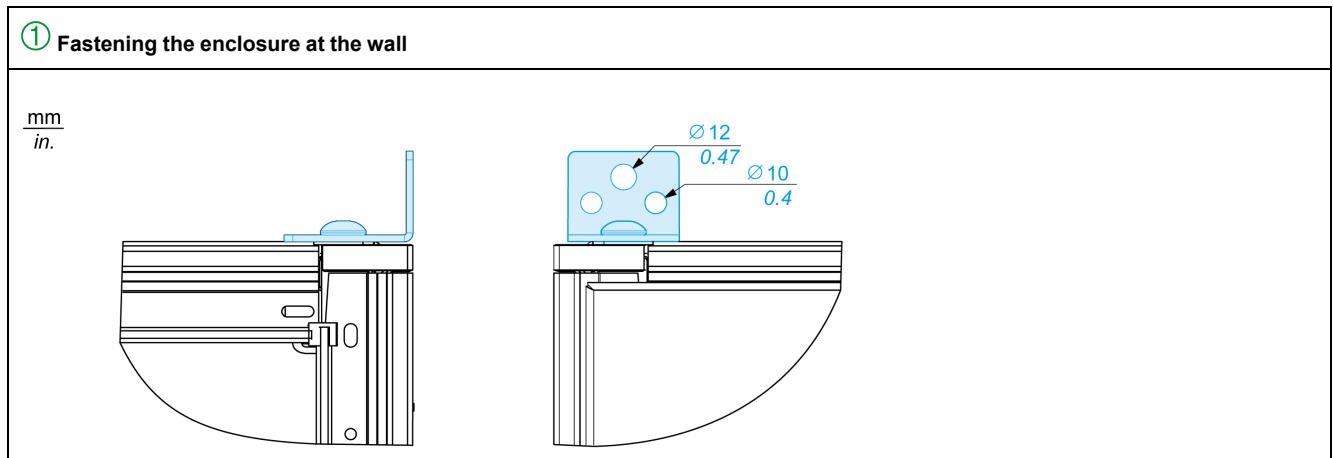
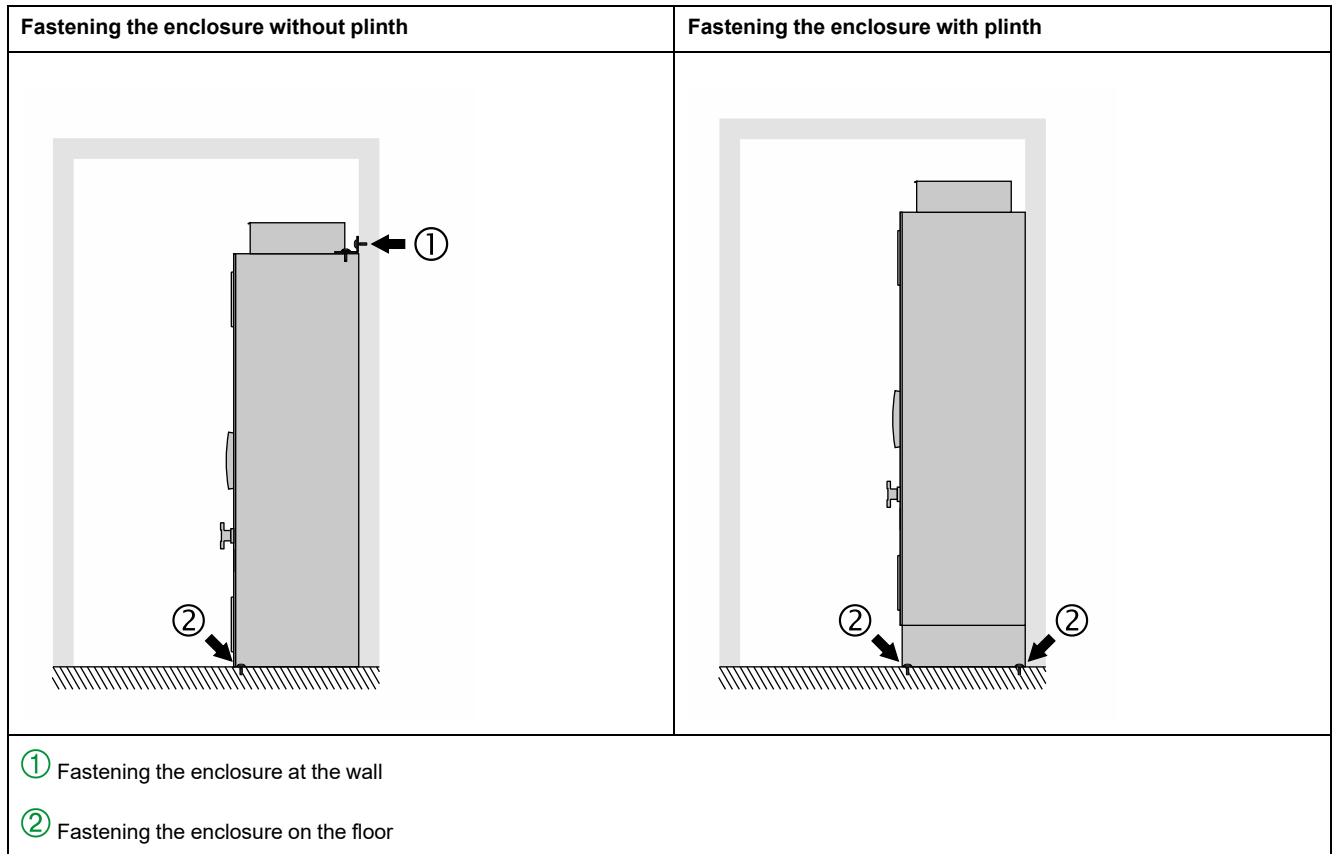

② Fastening the enclosure on the floor

Screw connection of an enclosure with plinth

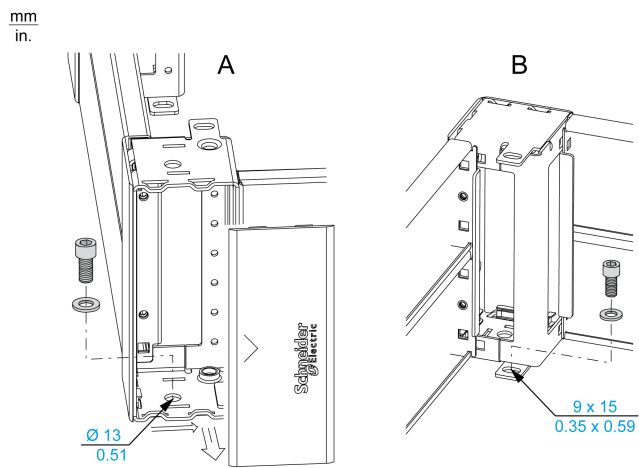

A Exterior view

B Interior view

Screw connection of an enclosure without plinth

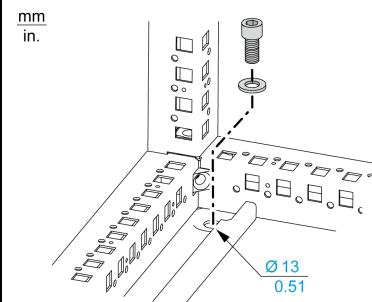

Wiring

What's in This Chapter

Wiring Instructions	28
Protective Grounding	29
EMC Grounding	29
Operation on an IT or Corner Grounded System	30
Disconnecting the Built-In EMC Filter	30
Shield of the Motor Cable	36
Connection of Power Cables	37
Connection of the Control Cables	42

Wiring Instructions

DANGER

ELECTRIC SHOCK CAUSED BY INSUFFICIENT GROUNDING

- Verify compliance with all local and national electrical code requirements as well as all other applicable regulations with respect to grounding of the entire device.
- Ground the device before applying voltage.
- The cross section of the protective ground conductor must comply with the applicable standards.
- Do not use conduits as protective ground conductors; use a protective ground conductor inside the conduit.
- Do not consider cable shields to be protective ground conductors.

Failure to follow these instructions will result in death or serious injury.

The product has a leakage current greater than 3.5 mA. If the protective ground connection is interrupted, a hazardous touch current may flow if the product is touched.

DANGER

ELECTRIC SHOCK CAUSED BY HIGH LEAKAGE CURRENT

Verify compliance with all local and national electrical code requirements as well as all other applicable regulations with respect to grounding of the entire drive system .

Failure to follow these instructions will result in death or serious injury.

DANGER

HAZARD OF ELECTRIC SHOCK, EXPLOSION, OR ARC FLASH

Before applying voltage to and configuring the product, verify that it is properly wired.

Failure to follow these instructions will result in death or serious injury.

NOTE: Terminals for external conductors are suitable for connection of copper and aluminium conductors.

Protective Grounding

There is a marked terminal (bar) inside the enclosure to connect the protective conductor. It is also used to connect the protective grounding of the motor.

Connect each inverter directly to the protective grounding as shown below.

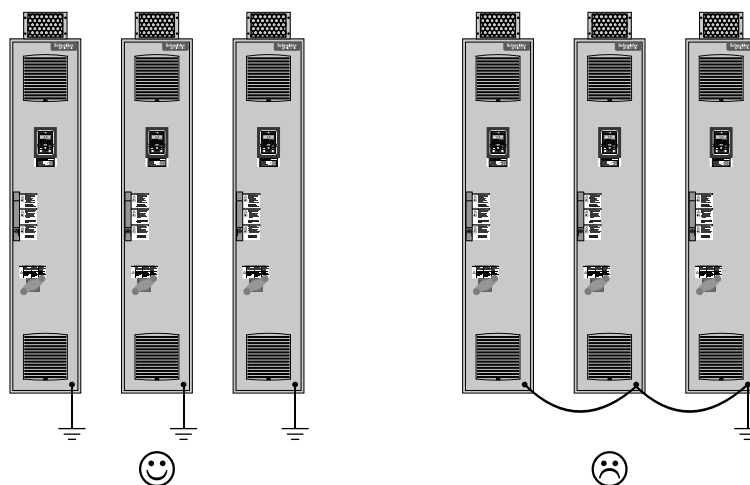

EMC Grounding

In addition to protective grounding, make ground connections with large surface which may be arranged parallel to the yellow-green protective grounding PE. The grounding lugs have to keep a minimum width of 40 mm (1.57 in).

Limit values

This product meets the EMC requirements according to the standard IEC 61800-3 if the measures described in this manual are implemented during installation.

If the selected composition (product itself, mains filter, other accessories and measures) does not meet the requirements of category C1, the following information applies as it appears in IEC 61800-3:

⚠ WARNING

RADIO INTERFERENCE

In a domestic environment this product may cause radio interference in which case supplementary mitigation measures may be required.

Failure to follow these instructions can result in death, serious injury, or equipment damage.

Operation on an IT or Corner Grounded System

Definition

IT system: Isolated or impedance grounded neutral. Use a permanent insulation monitoring device compatible with nonlinear loads, such as an XM200 type or equivalent.

Corner grounded system: System with one phase grounded.

Operation

NOTICE

OVERVOLTAGE OR OVERHEATING

If the drive is operated via an IT or corner grounded system, the integrated EMC filter must be disconnected as described in the present manual.

Failure to follow these instructions can result in equipment damage.

Disconnecting the Built-In EMC Filter

Filter Disconnection

⚡⚠ DANGER

HAZARD OF ELECTRIC SHOCK, EXPLOSION OR ARC FLASH



Read and understand the instructions in **Safety Information** chapter before performing any procedure in this chapter.

Failure to follow these instructions will result in death or serious injury.

The drives have a built-in EMC filter. As a result they exhibit leakage current to ground. If the leakage current creates compatibility problems with your installation (residual current device or other), then you can reduce the leakage current by disconnecting the built-in filter as shown below. In this configuration the product does not meet the EMC requirements according to the standard IEC 61800-3.

Altivar Process Drive Systems ATV•60, ATV•80, ATV99•

Apply the following instructions to disconnect the built-in EMC filter.

Step	Action
1	Remove the front cover.
2	The screw is factory set to the  position, as shown on detail ①
3	For operation without the built-in EMC filter, remove the screw from its location and set it to the  position, as shown on detail ②
4	Refit the front cover.

NOTE:

- Use only the screw supplied.
- Do not operate the drive with the setting screw removed.

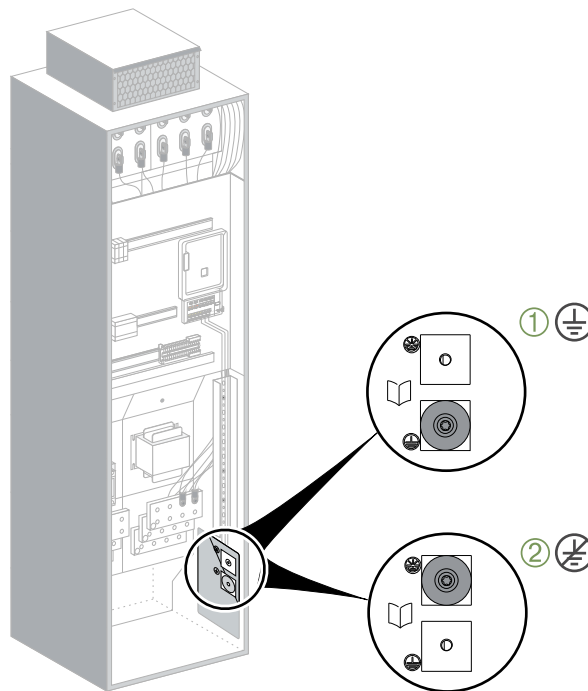





Altivar Process Drive Systems ATV•30

Refer to the ATV630, ATV650 Installation manual or to the ATV930, ATV950 Installation manual available on www.se.com.

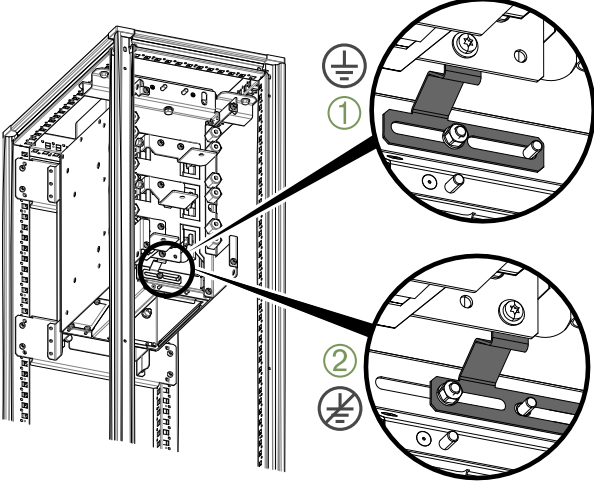
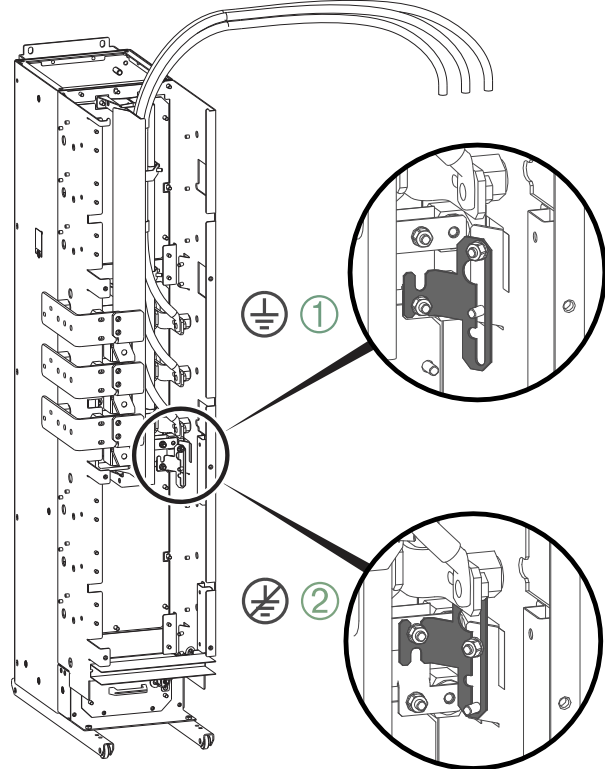
Altivar Process Modular Drive Systems ATV•A0





Apply the following instructions to disconnect the built-in EMC filter.

Step	Action
1	<div style="display: flex; justify-content: space-between;"> <div style="width: 48%;"> <p>Standard integration: Remove the mains unit cover.</p>  </div> <div style="width: 48%;"> <p>Reduced height integration: Remove the cover of the mains module reduced height integration.</p>  </div> </div>
2	<p>The EMC filter bracket is factory set to the  position, as shown on detail </p>
3	<p>For operation without the built-in EMC filter (on IT system), move the EMC filter bracket from its position to the  position, as shown on detail </p>
4	<p>Refit the cover</p>

NOTE: Do not operate the module with the EMC filter bracket removed.

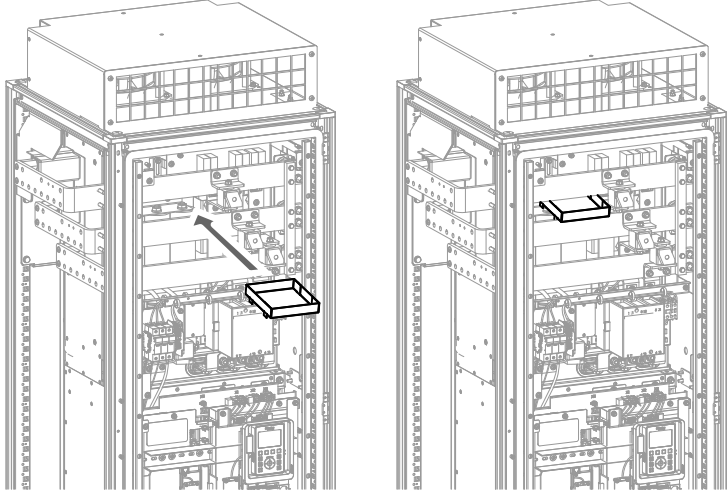
Altivar Process Modular Drive Systems ATV•B0

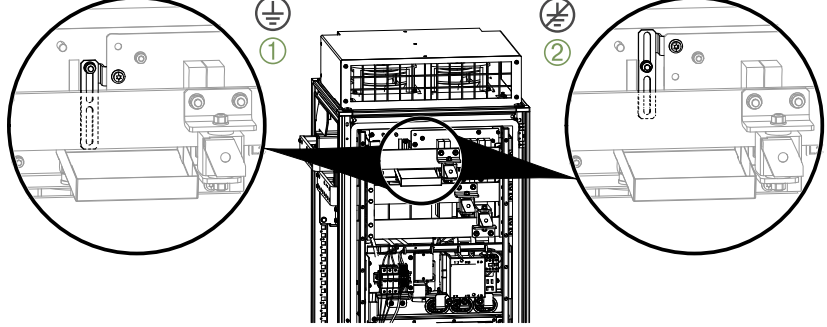





Apply the following instructions to disconnect the built-in EMC filter.

Step	Action
1	Remove the cover of the mains part, if required.
2	Slide a box below the EMC filter bracket. This box helps to prevent losing the screw when it falls down during unscrewing.
	
3	The EMC filter bracket is factory set to the  position, as shown on detail  .
	
4	For operation without the built-in EMC filter (on IT system), move the EMC filter bracket from its position to the  position, as shown on detail  .
5	Remove the box.
6	Refit the cover of the mains part.

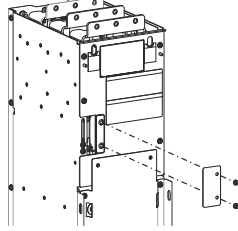
NOTE: Do not operate the module with the EMC filter bracket removed.

Altivar Process Modular Drive Systems ATV•L0 Universal

Apply the following instructions to set the EMC filter from TT/TN to IT system (or to the test position before performing the high potential test).



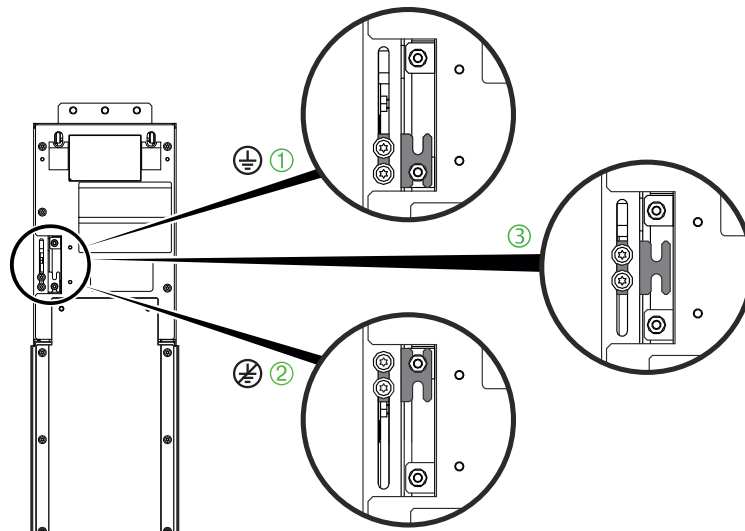

Step	Action
1	Remove the EMC filter bracket cover on the line choke module. 
2	The EMC filter bracket is factory set to the  position, as shown on detail  .
3	For operation without the built-in EMC filter (on IT system), move the EMC filter bracket from its position to the  position, as shown on detail  .
4	Before performing the high potential test move the EMC filter bracket to the test position, as shown in detail  . After completion of the high potential test move the bracket to its proper position.
5	Refit the EMC filter bracket cover.





NOTE: Do not operate the module with the EMC filter bracket removed or with the EMC filter bracket in the middle position .

Altivar Process Modular Drive Systems ATV•L0 Compact

Apply the following instructions to set the EMC filter from TT/TN to IT system (or to the test position before performing the high potential test).

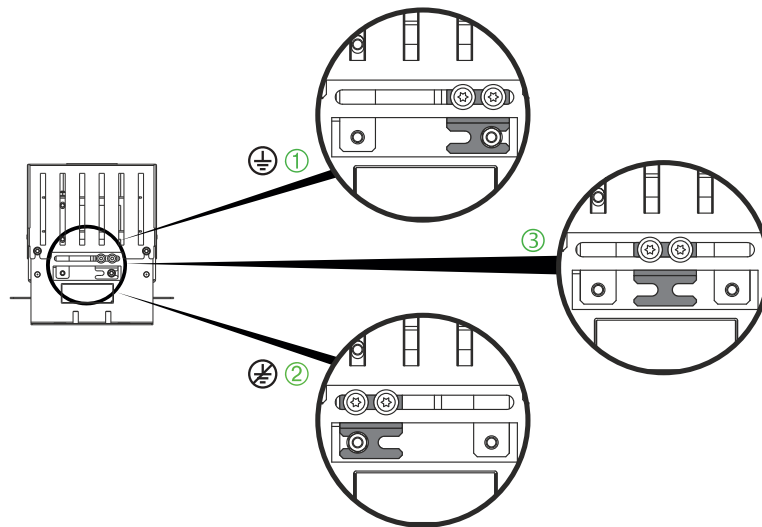
Step	Action
1	The EMC filter bracket is factory set to the  position, as shown on detail  .
2	For operation without ground connection of the EMC filter (on IT system), move the EMC filter bracket from its position to the  position, as shown on detail  .
3	Before performing the high potential test move the EMC filter bracket to the test position, as shown in detail  . After completion of the high potential test move the bracket to its proper position.



NOTE: Do not operate the module with the EMC filter bracket removed or with the EMC filter bracket in the middle position .

Shield of the Motor Cable

The shield of the motor cable returns the interference currents back to the mains filter of the inverter.

Furthermore the shield of the motor cable reduces the radiated emissions as well as the coupling into neighboring lines.

Therefore, it is recommended to use shielded 4-pole motor cables and to connect the shield at both ends in accordance with the valid HF rules. The type of shield material (copper or steel) is less significant than the well connection at both ends. Alternatively, a metallic, closed and well conductive cable conduit can be used which is continuously connected.

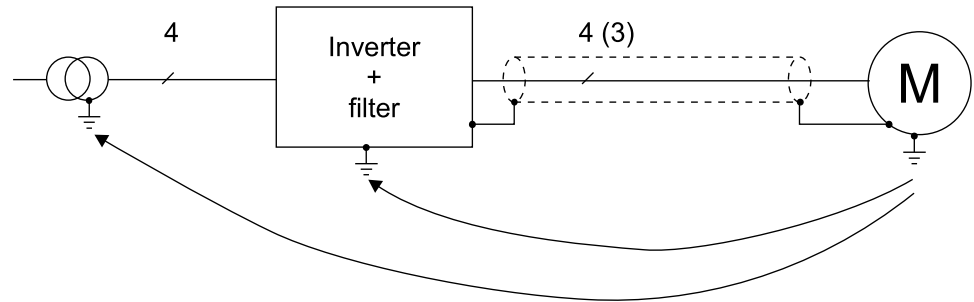

Connection of Power Cables

⚠️ DANGER

HAZARD OF ELECTRIC SHOCK, EXPLOSION OR ARC FLASH

- Verify that the cables are properly installed as specified.
- Ensure protection against contact with live parts in the entire installation, including cables.
- Ensure adequate sealing of the cable entries.
- Before commissioning, verify that the degree of protection specified on the nameplate and in all pertinent product documentation is achieved.

Failure to follow these instructions will result in death or serious injury.

General Information on Connection of Power Cables

Note the correct connection type:

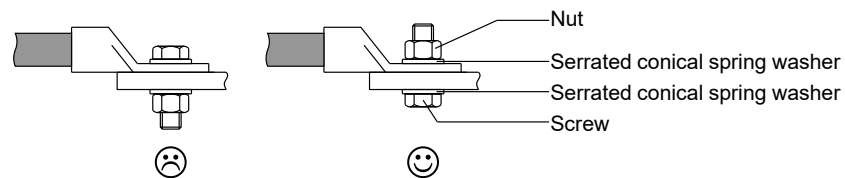

Terminals with mounting hole:

Material per mounting hole	M10 mounting hole	M12 mounting hole
1x nut ⁽¹⁾	M10 27 Nm / 239 lbf.in	M12 45 Nm / 398 lbf.in
2x serrated conical spring washer ⁽²⁾	M10	M12
1x screw ⁽¹⁾	M10x25	M12x35
(1) Property class 8.8 according ISO 4017 or DIN 933		
(2) According ISO 4032 or DIN 934		

Altivar Process Drive Systems ATV•60, ATV•80, ATV99•

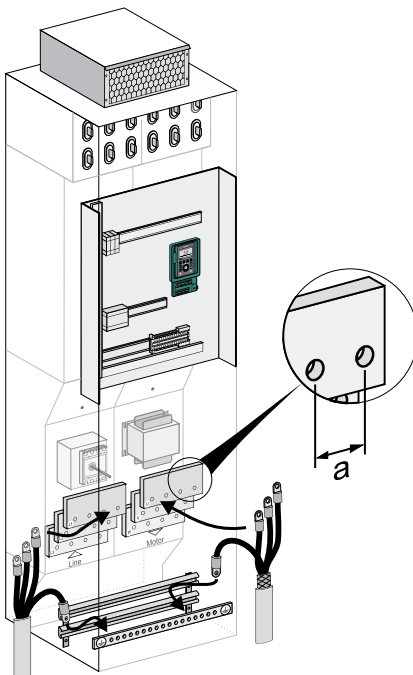
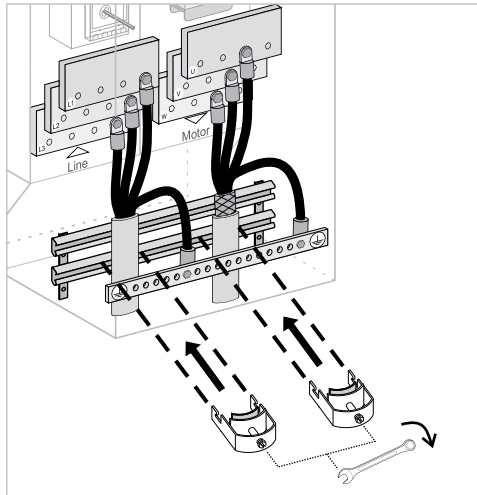
Step	Action						
1	<p>Connect the mains cable to terminals L1/R, L2/S, L3/T and the motor cable to terminals U/T1, V/T2, W/T3 as well as the PE conductor to the ground bar.</p>  <table border="1" data-bbox="1018 604 1436 779"> <thead> <tr> <th>Size</th> <th>Distance a</th> </tr> </thead> <tbody> <tr> <td>1p...3p 1a...3a</td> <td>40 mm (1.57 in)</td> </tr> <tr> <td>4p...6p 4a...6a</td> <td>42 mm (1.65 in)</td> </tr> </tbody> </table>	Size	Distance a	1p...3p 1a...3a	40 mm (1.57 in)	4p...6p 4a...6a	42 mm (1.65 in)
Size	Distance a						
1p...3p 1a...3a	40 mm (1.57 in)						
4p...6p 4a...6a	42 mm (1.65 in)						
2	<p>Fix the mains cable with a metal cable clamp (type AC) to the related bar now. Mount at the motor cable the insulated part of the motor cable to the lower EMC shield bar using a metal cable clamp.</p> <p>NOTE: Clamp a small plastic plate between the motor cable and the metal cable clamp to help to prevent the cable from damage.</p> 						

- 3 Fix the upper part (cable shield) of the motor cable using a metal cable clamp (type AC) to the upper EMC shield bar.

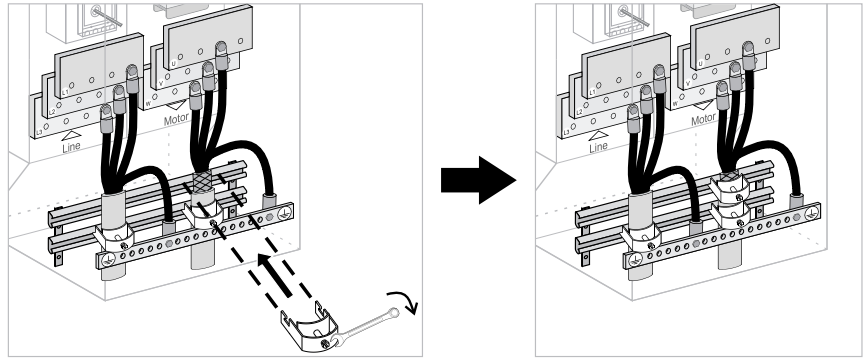

Altivar Process Drive Systems ATV•A0, ATV•B0, ATV•L0 and ATV•30

Mains connection

Step	Action														
1	Connect the mains cable to terminals provided (marked L1, L2, L3) and the PE conductor to the grounding bar (marked PE).														
2	<p>Due to the high flexibility and diversity of the Altivar Process Drive systems, there are two possible variants for mechanical strain relief:</p> <p>Variant A (mechanical strain relief with metal clamp):</p> <table border="1"> <thead> <tr> <th>Step</th> <th>Action</th> </tr> </thead> <tbody> <tr> <td>1</td> <td> <p>Attach the insulated part of the mains cable by a metal clamp (type AC, not included in delivery) to the rail "a" provided for mechanical strain relief.</p> <p>NOTE: To protect the cable, clamp a plastic strip between the mains cable and the metal clip.</p> </td> </tr> </tbody> </table> <p>Variant B (mechanical strain relief with cable gland):</p> <table border="1"> <thead> <tr> <th>Step</th> <th>Action</th> </tr> </thead> <tbody> <tr> <td>1</td> <td>Remove the gland plate "b" from the cabinet. Modify these by providing appropriate feed-through openings. The number, position and diameter need to correspond with the conditions on site and the cable glands used (not included in the scope of delivery).</td> </tr> <tr> <td>2</td> <td>Fasten the cable gland to the gland plate.</td> </tr> <tr> <td>3</td> <td>Return the gland plate to its original position and fix it.</td> </tr> <tr> <td>4</td> <td>Tighten the cable gland.</td> </tr> </tbody> </table>	Step	Action	1	<p>Attach the insulated part of the mains cable by a metal clamp (type AC, not included in delivery) to the rail "a" provided for mechanical strain relief.</p> <p>NOTE: To protect the cable, clamp a plastic strip between the mains cable and the metal clip.</p>	Step	Action	1	Remove the gland plate "b" from the cabinet. Modify these by providing appropriate feed-through openings. The number, position and diameter need to correspond with the conditions on site and the cable glands used (not included in the scope of delivery).	2	Fasten the cable gland to the gland plate.	3	Return the gland plate to its original position and fix it.	4	Tighten the cable gland.
Step	Action														
1	<p>Attach the insulated part of the mains cable by a metal clamp (type AC, not included in delivery) to the rail "a" provided for mechanical strain relief.</p> <p>NOTE: To protect the cable, clamp a plastic strip between the mains cable and the metal clip.</p>														
Step	Action														
1	Remove the gland plate "b" from the cabinet. Modify these by providing appropriate feed-through openings. The number, position and diameter need to correspond with the conditions on site and the cable glands used (not included in the scope of delivery).														
2	Fasten the cable gland to the gland plate.														
3	Return the gland plate to its original position and fix it.														
4	Tighten the cable gland.														

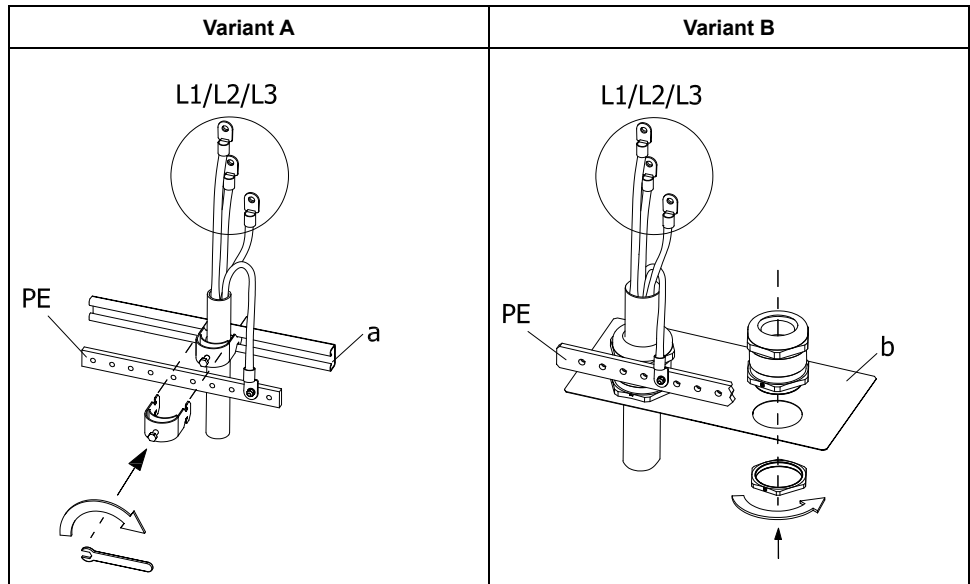

- PE ... Grounding bar
- a ... Rail for mechanical strain relief
- b ... Gland plate (removable for modification)

Motor connection

Step	Action										
1	Connect the motor cable to terminals provided (marked U, V, W) and the PE conductor to the grounding bar (marked PE).										
2	Due to the high flexibility and diversity of the Altivar Process Drive systems, there are two possible connection variants for the cable shield: Variant A (EMC shield and mechanical strain relief separately):										
<table border="1"> <thead> <tr> <th>Step</th> <th>Action</th> </tr> </thead> <tbody> <tr> <td>1</td> <td>Fasten the insulated part of the motor cable by means of a metal clamp (type AC, not included in delivery) to the rail "a" provided for mechanical strain relief. NOTE: To protect the cable, clamp a plastic strip between the motor cable and the metal clip.</td> </tr> <tr> <td>2</td> <td>Now attach the upper part of the motor cable (cable shield) with a large surface to the EMC shield rail "b" using a metal clamp (type AC, not included in the scope of delivery).</td> </tr> </tbody> </table>		Step	Action	1	Fasten the insulated part of the motor cable by means of a metal clamp (type AC, not included in delivery) to the rail "a" provided for mechanical strain relief. NOTE: To protect the cable, clamp a plastic strip between the motor cable and the metal clip.	2	Now attach the upper part of the motor cable (cable shield) with a large surface to the EMC shield rail "b" using a metal clamp (type AC, not included in the scope of delivery).				
Step	Action										
1	Fasten the insulated part of the motor cable by means of a metal clamp (type AC, not included in delivery) to the rail "a" provided for mechanical strain relief. NOTE: To protect the cable, clamp a plastic strip between the motor cable and the metal clip.										
2	Now attach the upper part of the motor cable (cable shield) with a large surface to the EMC shield rail "b" using a metal clamp (type AC, not included in the scope of delivery).										
Variant B (EMC shielding and mechanical strain relief using EMC cable gland):											
<table border="1"> <thead> <tr> <th>Step</th> <th>Action</th> </tr> </thead> <tbody> <tr> <td>1</td> <td>Remove the shield or gland plate "c" from the cabinet. Modify these by providing appropriate feed-through openings. The number, position and diameter need to correspond with the conditions on site and the EMC cable glands used (not included in the scope of delivery).</td> </tr> <tr> <td>2</td> <td>Fasten the cable gland to the gland plate.</td> </tr> <tr> <td>3</td> <td>Return the screen or gland plate to its original position and fix it.</td> </tr> <tr> <td>4</td> <td>Ensure that the shield of the motor cable is connected to the EMC gland with a large surface and tighten it properly.</td> </tr> </tbody> </table>		Step	Action	1	Remove the shield or gland plate "c" from the cabinet. Modify these by providing appropriate feed-through openings. The number, position and diameter need to correspond with the conditions on site and the EMC cable glands used (not included in the scope of delivery).	2	Fasten the cable gland to the gland plate.	3	Return the screen or gland plate to its original position and fix it.	4	Ensure that the shield of the motor cable is connected to the EMC gland with a large surface and tighten it properly.
Step	Action										
1	Remove the shield or gland plate "c" from the cabinet. Modify these by providing appropriate feed-through openings. The number, position and diameter need to correspond with the conditions on site and the EMC cable glands used (not included in the scope of delivery).										
2	Fasten the cable gland to the gland plate.										
3	Return the screen or gland plate to its original position and fix it.										
4	Ensure that the shield of the motor cable is connected to the EMC gland with a large surface and tighten it properly.										

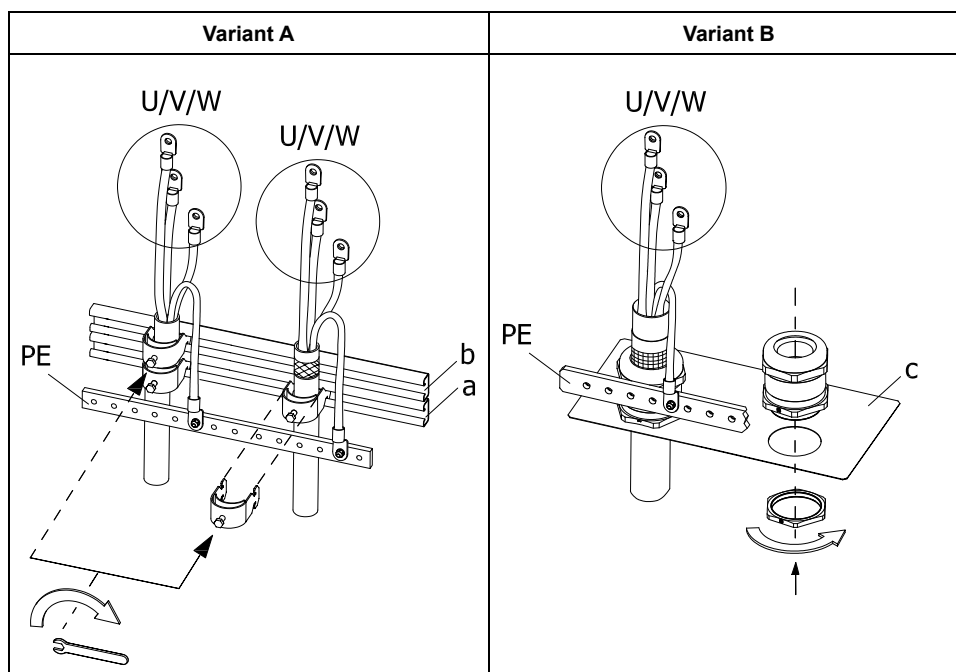

PE ... Grounding bar

a ... Rail for mechanical strain relief

b ... EMC shield rail (marked SCREEN)

c ... EMC shield or gland plate (removable for modification)

Connection of the Control Cables

DANGER

HAZARD OF ELECTRIC SHOCK, EXPLOSION OR ARC FLASH

- Verify that the temperature sensors in the motor meet the PELV requirements.
- Verify that the motor encoder meets the PELV requirements.
- Verify that any other equipment connected via signal cables meets the PELV requirements.

Failure to follow these instructions will result in death or serious injury.

Signal interference can cause unexpected responses of the drive and of other equipment in the vicinity of the drive.

WARNING

SIGNAL AND EQUIPMENT INTERFERENCE

- Install the wiring in accordance with the EMC requirements described in this document.
- Verify compliance with the EMC requirements described in this document.
- Verify compliance with all EMC regulations and requirements applicable in the country in which the product is to be operated and with all EMC regulations and requirements applicable at the installation site.

Failure to follow these instructions can result in death, serious injury, or equipment damage.

DANGER

ELECTRIC SHOCK CAUSED BY INCORRECT POWER SUPPLY UNIT

The +24VDC supply voltage is connected with many exposed signal connections in the drive system.

- Use a power supply unit that meets the PELV (Protective Extra Low Voltage) requirements.

Failure to follow these instructions will result in death or serious injury.

NOTICE

INCORRECT VOLTAGE

Supply the digital inputs with 24 Vdc only.

Failure to follow these instructions can result in equipment damage.

Control part

⚠ WARNING

UNANTICIPATED EQUIPMENT OPERATION

Verify that the digital and analog inputs and outputs are wired with the shielded, twisted pair cables specified in the present manual.

Failure to follow these instructions can result in death, serious injury, or equipment damage.

- Do not route 24 V signal cables next to power cables. For digital and analog inputs and outputs, use shielded twisted-pair cables with a pitch length of 25...50 mm (1...2 in.).
- Use wire ferrules, available on www.se.com.

NOTE:

- Use shielded cables for the analog inputs and outputs AIx, Ayx and COM. Each analog input and output has its own COM terminal.
- Each PTC input has its own COM terminal, not shared with other inputs and outputs.
- All digital inputs DIx use one common 24 V potential in source mode or one common COM potential in sink mode. This 24 V or COM potential is used only for DIx.
- Digital output DQ+/DQ- uses a 24 V or COM line which is not shared with other inputs and outputs.
- Use shielded cables and the common 24 V potential for the inputs $\overline{\text{STOA}}$ / $\overline{\text{STOB}}$. This 24 V potential is used only for $\overline{\text{STOA}}$ / $\overline{\text{STOB}}$.

Altivar Process Drive Systems ATV●60, ATV●80, ATV99●

The signal wires are wired to the terminals via the internal cable conduit.

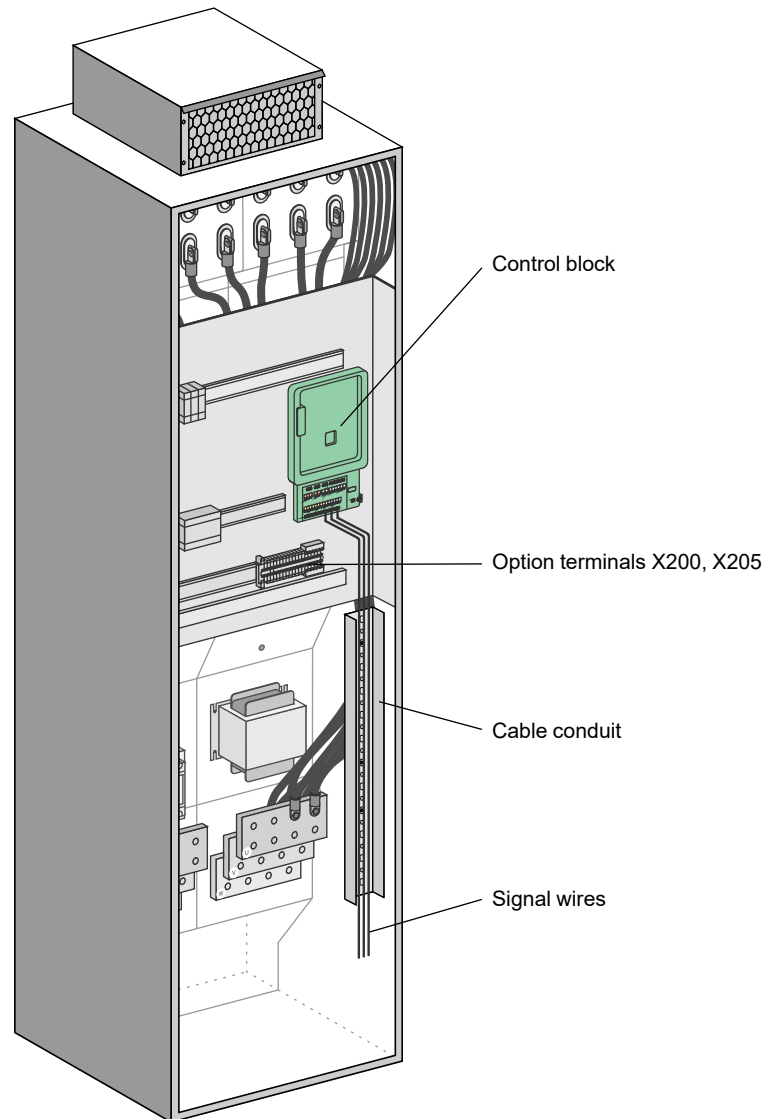

Altivar Process Modular Drive Systems ATV•A0, ATV•B0, ATV•L0 and ATV•30

The signal wires are wired to the terminals via the internal cable conduit.

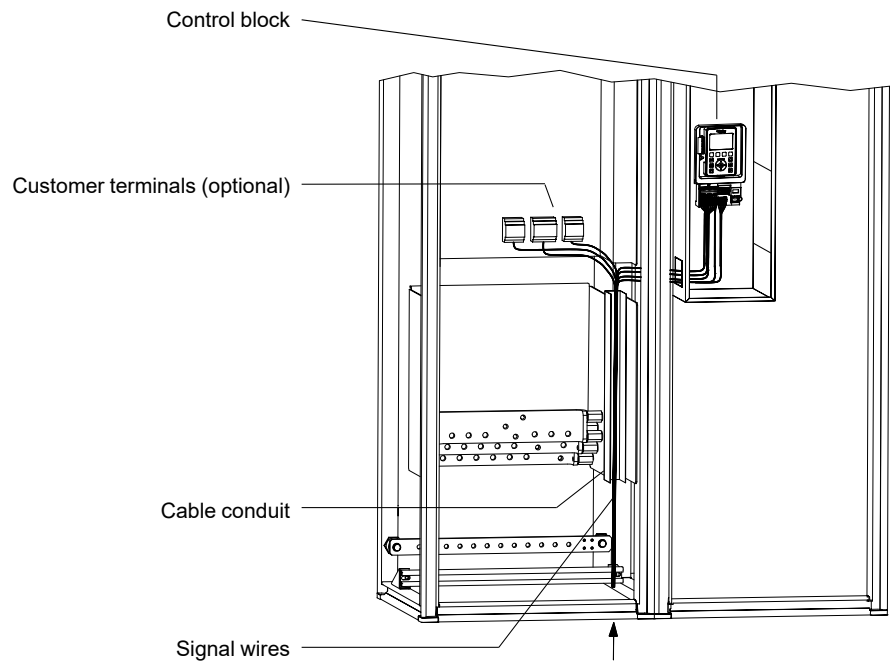

Control Terminals at the ATV6 Control Block

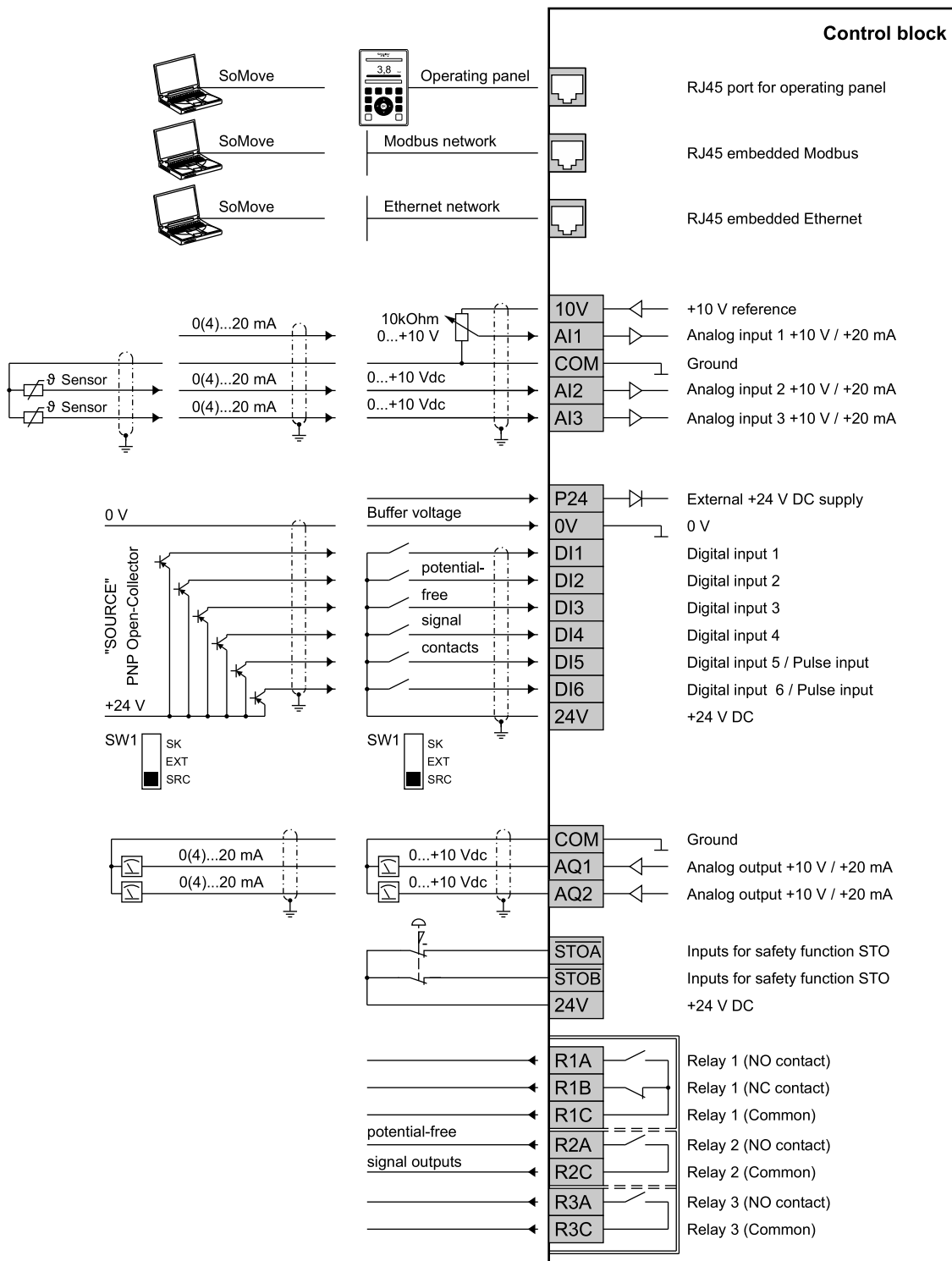

Screw terminals

Maximum cable cross section for all terminals:

- 1.5 mm² (AWG 16), 0.25 Nm (2.2 lbf.in)

Minimum cable cross section:

- For relay terminals 0.75 mm² (AWG 18)
- For all other terminals 0.5 mm² (AWG 20)
- Stripping length: 10 mm (0.39 in.)

Maximum length of signal wires: 50 m (164 ft)

Control Terminals at the ATV9●● Control Block

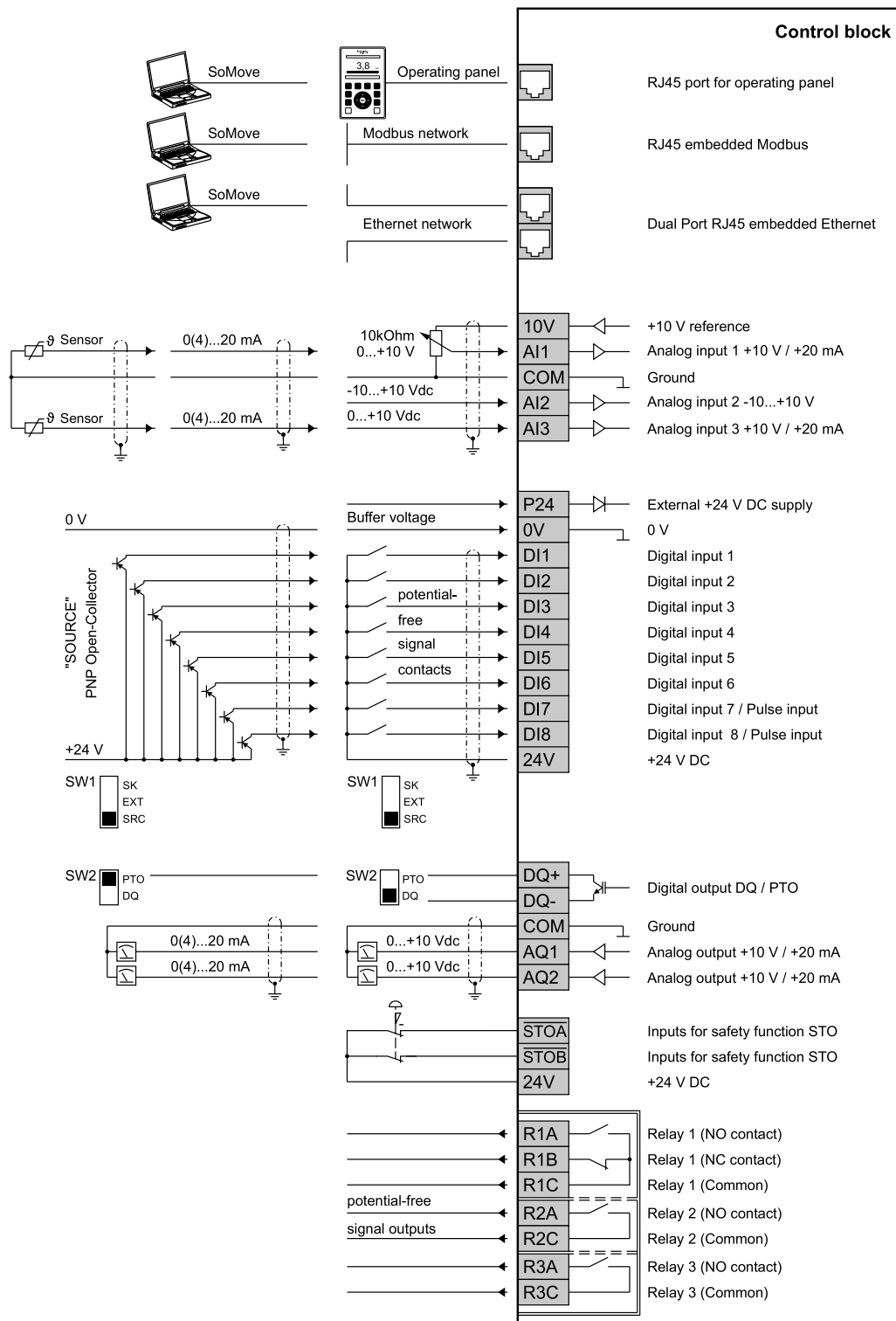

Screw terminals

Maximum cable cross section for all terminals:

- 1.5 mm² (AWG 16), 0.25 Nm (2.2 lbf.in)

Minimum cable cross section:

- For relay terminals 0.75 mm² (AWG 18)
- For all other terminals 0.5 mm² (AWG 20)
- Stripping length: 10 mm (0.39 in.)

Maximum length of signal wires: 50 m (164 ft)

Option "Logic and Analog I/O Card"

Option to expand the control inputs and control outputs of the control block. The expansion card contains two analog inputs, six digital inputs and two digital outputs.

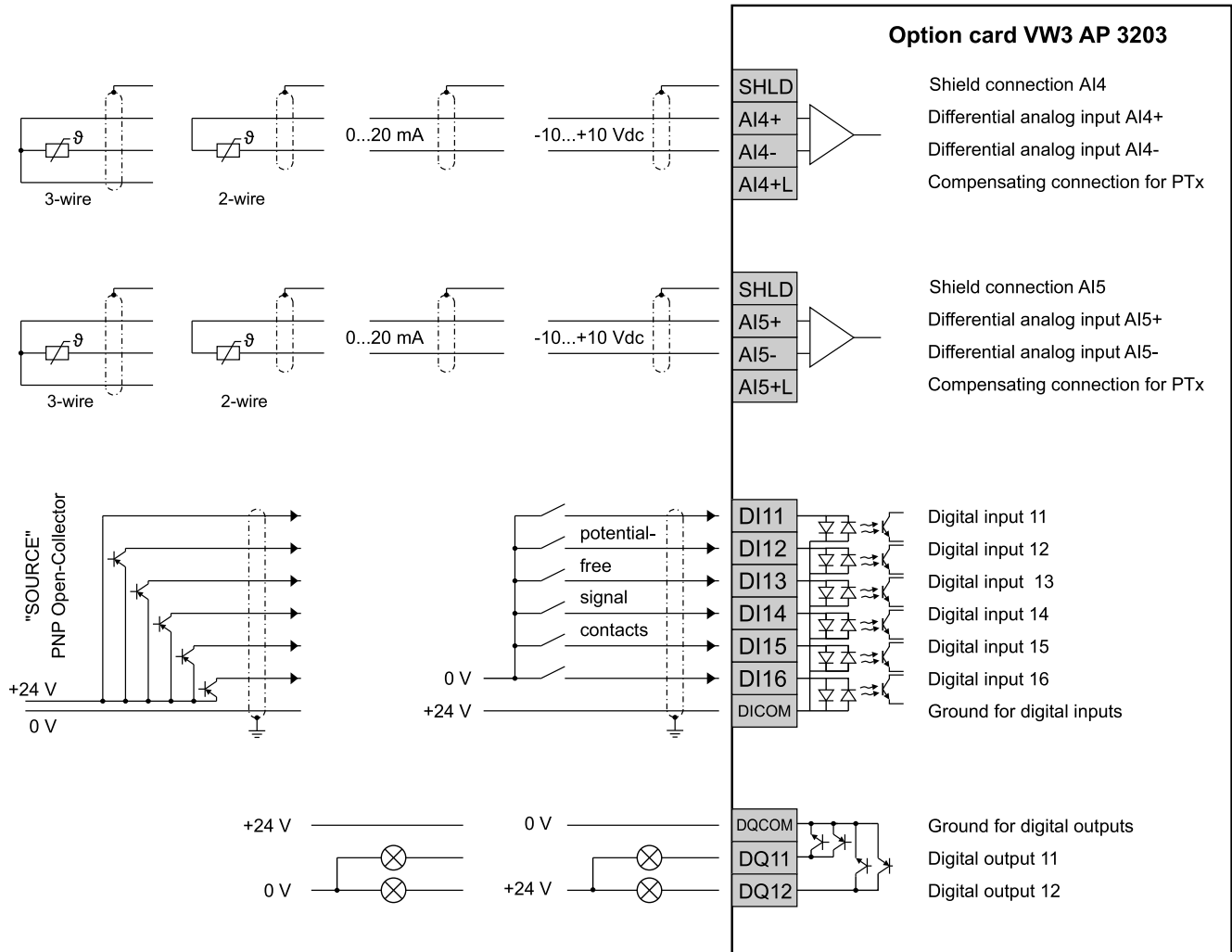

Spring terminals

Maximum cable cross section: 1 mm² (AWG 16)

Stripping length: 10 mm (0.39 in.)

Maximum length of signal wires: 50 m (164 ft)

Option "Relay Output Card"

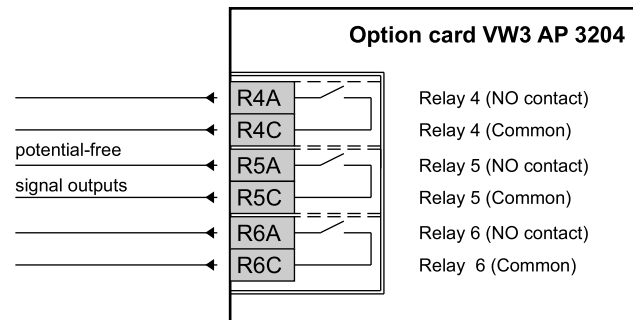

Screw terminals

Maximum cable cross section: 1.5 mm² (AWG 16)

Maximum tightening torque: 0.5 Nm (4.4 lbf.in)

Maximum cable cross section: 0.75 mm² (AWG 18)

Stripping length: 10 mm (0.39 in.)

Liquid Cooling ATV•L0

What's in This Chapter

General Specifications.....51

General Specifications

Introduction

DANGER

HAZARD OF ELECTRIC SHOCK, EXPLOSION, OR ARC FLASH

- Verify that coolant cannot come into contact with live parts.
- Verify that the cooling system is operated within the specified temperature and humidity limits.

Failure to follow these instructions will result in death or serious injury.

WARNING

INOPERATIVE AND/OR INSUFFICIENT COOLING SYSTEM

- Include the cooling system in your risk assessment.
- Do not operate the product without cooling.
- Verify that the cooling system is monitored in a sufficient way (for example, by means of temperature monitoring, flow monitoring, leak monitoring and/or pressure monitoring).
- Implement suitable measures (for example, connection of the cooling system to the master controller) to ensure that the process can reach a safe state as defined in your risk assessment if the specified temperatures are exceeded.
- Verify that no extraneous objects or substances can get into the cooling system (for example, by means of a suitable filter and/or by conditioning the coolant).
- Verify that the coolant you select meets all requirements specified in the present document and that it is suitable for the parts of the cooling system you install.
- Before commissioning the cooling system, perform comprehensive tests to verify the effectiveness of the cooling system.

Failure to follow these instructions can result in death, serious injury, or equipment damage.

Standard Cooling Cabinet

The APM liquid-cooled Single Drive ATV•L0 with water-water re-cooling system is equipped with a cooling cabinet as standard. Therefore, the customer needs to make the hose connection. The position of the cabinet depends on whether it is a Universal or a Compact Single Drive and can be either the far left or the far right cabinet.

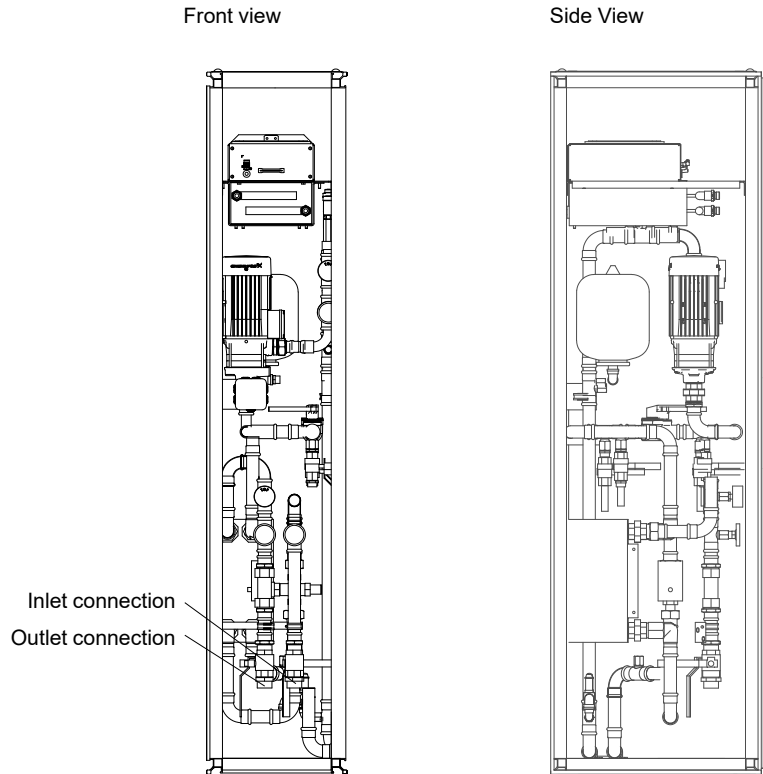

The size of the inlet and outlet fittings may be different depending on the power of the drive:

380...480 V Mains supply

Modular Single Drive ATV•L0	Inlet and outlet connection
	Thread size
from C13•4 up to M12•4	1" external thread, cylindric (flat sealing)
from M15•4 up to M18•4	5/4" external thread, cylindric (flat sealing)

500...690 V Mains supply

Modular Single Drive ATV•L0	Inlet and outlet connection
	Thread size
from C20•6 up to M18•6	1" external thread, cylindric (flat sealing)
from M22•6 up to M26•6	5/4" external thread, cylindric (flat sealing)

Coolant

Depending on the environmental conditions we recommend two different types of coolant for the cooling circuit:

- Industrial water (process water)
- Water-glycol-mixture

Industrial water (process water)

The cleanness of the water and the content of corrosive substances is significant for the availability and the maintenance intervals of the whole drive unit.

Check the process water for the following limits:

Characteristics	Limit
pH-value	6...9
Degree of hardness	< 20°dH
Chlorides	< 100 mg/l
Iron	< 0.5 mg/l
Particle size	max. 300 µm

Water-glycol-mixture

At a mixture ratio of 60 % water and 40 % Antifrogen N (company Clariant) the freezing point is at -25°C (-13°F). A higher glycol ratio reduces the heat conduction, a lower ratio reduces the frost resistance. The coolant corresponds with water pollution class 1 according VwVwS 1999. Observe DIN 52 900 (about propandiol and ethylene glycol) when disposing the coolant.

Commissioning

What's in This Chapter

Proceeding 55

Proceeding

DANGER

HAZARD OF ELECTRIC SHOCK, EXPLOSION OR ARC FLASH

Read and understand the instructions in **Safety Information** chapter before performing any procedure in this chapter.

Failure to follow these instructions will result in death or serious injury.

Inspection

Inspection of power wiring

Step	Action	✓
1	Check the power supply connection to the terminals provided for the mains voltage.	
2	Check the proper grounding of the enclosure for the purpose of human protection.	
3	Check the size of the pre-fuses.	
4	Verify the length of the motor cable corresponds to the permitted limits.	

Inspection of EMC measures

Step	Action	✓
1	Check whether there is a well HF connection between the shield of the motor cable, the motor and the inverter.	
2	All low-level signal wires (also the digital inputs) have to be shielded and taken separately from the motor cables.	
3	The enclosure requires a large surface connection to ground in order to keep the permitted interference limits.	

EMERGENCY STOP system

Step	Action	✓
1	Check all EMERGENCY STOP functions of the Altivar Process Drive System.	
2	Check the EMERGENCY STOP function of the (main) power supply.	

Inspection of the cooling system (only valid for ATV•L0 drives):

Step	Action	✓
1	Check that the coolant inlet and outlet connections are properly connected to the cooling system.	
2	Check the tightness of the cooling system.	

Long-term Storage

Capacitor Reforming

If the drive was not connected to mains for an extended period of time, the capacitors must be restored to their full performance before the motor is started.

NOTICE
<p>REDUCED CAPACITOR PERFORMANCE</p> <ul style="list-style-type: none"> • Apply mains voltage to the drive for one hour before starting the motor if the drive has not been connected to mains for the specified periods of time.(1) • Verify that no Run command can be applied before the period of one hour has elapsed. • Verify the date of manufacture if the drive is commissioned for the first time and run the specified procedure if the date of manufacture is more than 12 months in the past. <p>Failure to follow these instructions can result in equipment damage.</p>

(1) Period of time:

- 12 months at a maximum storage temperature of +50°C (+122°F)
- 24 months at a maximum storage temperature of +45°C (+113°F)
- 36 months at a maximum storage temperature of +40°C (+104°F)

If the specified procedure cannot be performed without a Run command because of internal mains contactor control, perform this procedure with the power stage enabled, but the motor being at a standstill so that there is no appreciable mains current in the capacitors.

Power Up the Device Without Start of the Motor

Step	Action	✓
1	Ensure that the inputs $\overline{\text{STOA}}$ and $\overline{\text{STOB}}$ are deactivated (state 0).	
2	If existing, check the external control voltage and ask the responsible person to switch on.	
3	Check by control measurements whether all phase voltages are existing and whether they are symmetrical.	
4	<p>Check whether the mains data correspond with the specification on the name plate:</p> <ul style="list-style-type: none"> • Mains voltage • Type of mains • Mains frequency • Mains short-circuit power <p>After that, ask the responsible person for switching on the mains voltage.</p>	
5	Switch on the main switch or circuit breaker.	
6	Check the control and the settings of the motor circuit breaker according to the delivered circuit diagrams and put it into operation.	

NOTICE
<p>DESTRUCTION DUE TO INCORRECT MAINS VOLTAGE</p> <p>Before switching on and configuring the product, verify that it is approved for the mains voltage.</p> <p>Failure to follow these instructions can result in equipment damage.</p>

Unsuitable settings or unsuitable data or unsuitable wiring may trigger unintended movements, trigger signals, damage parts and disable monitoring functions.

▲ WARNING

UNANTICIPATED EQUIPMENT OPERATION

- Only start the system if there are no persons or obstructions in the zone of operation.
- Verify that a functioning emergency stop push-button is within reach of all persons involved in the operation.
- Do not operate the product with unknown settings or data.
- Verify that the wiring is appropriate for the settings.
- Never modify a parameter unless you fully understand the parameter and all effects of the modification.
- When commissioning, carefully run tests for all operating states, operating conditions and potential error situations.
- Anticipate movements in unintended directions or oscillation of the motor.

Failure to follow these instructions can result in death, serious injury, or equipment damage.

Parameterizing

Basic setting at the operating panel

Step	Action	✓
1	If requested, set the date, time and language.	
2	Check the parameter for the mains voltage and adapt it according to the used mains voltage, if required.	
3	Adjust the parameters according to the requirements of the application.	

Acquire the motor data

Step	Action	✓																														
1	<p>Set the following parameters in menu [Simply start] according to the specification on the name plate of the motor.</p> <table border="1"> <thead> <tr> <th>Parameter</th> <th>Description</th> <th>Factory setting</th> </tr> </thead> <tbody> <tr> <td>[Basic Frequency] bFr</td> <td>Basic frequency of the motor (Hz)</td> <td>[50 Hz IEC] 50</td> </tr> <tr> <td>[Nominal motor power] nPr</td> <td>Nominal motor power given on the name plate (kW)</td> <td>Dependent on type</td> </tr> <tr> <td>[Nom Motor Voltage] unS</td> <td>Nominal motor voltage given on the name plate (VAC)</td> <td>Dependent on type</td> </tr> <tr> <td>[Nom Motor Current] nCr</td> <td>Nominal motor current given on the name plate (A)</td> <td>Dependent on type</td> </tr> <tr> <td>[Nominal Motor Freq] FrS</td> <td>Nominal motor frequency given on the name plate (Hz)</td> <td>50</td> </tr> <tr> <td>[Nominal Motor Speed] nSP</td> <td>Nominal motor speed given on the name plate (rpm)</td> <td>Dependent on type</td> </tr> <tr> <td>[Max Frequency] tFr</td> <td>Maximum motor frequency (Hz)</td> <td>60</td> </tr> <tr> <td>[Motor Th Current] iTh</td> <td>Thermal motor current given on the name plate (A)</td> <td>Dependent on type</td> </tr> <tr> <td>[2/3-Wire Control] tCC</td> <td>Control command by 2-wire or 3-wire control</td> <td>2C</td> </tr> </tbody> </table>	Parameter	Description	Factory setting	[Basic Frequency] bFr	Basic frequency of the motor (Hz)	[50 Hz IEC] 50	[Nominal motor power] nPr	Nominal motor power given on the name plate (kW)	Dependent on type	[Nom Motor Voltage] unS	Nominal motor voltage given on the name plate (VAC)	Dependent on type	[Nom Motor Current] nCr	Nominal motor current given on the name plate (A)	Dependent on type	[Nominal Motor Freq] FrS	Nominal motor frequency given on the name plate (Hz)	50	[Nominal Motor Speed] nSP	Nominal motor speed given on the name plate (rpm)	Dependent on type	[Max Frequency] tFr	Maximum motor frequency (Hz)	60	[Motor Th Current] iTh	Thermal motor current given on the name plate (A)	Dependent on type	[2/3-Wire Control] tCC	Control command by 2-wire or 3-wire control	2C	
Parameter	Description	Factory setting																														
[Basic Frequency] bFr	Basic frequency of the motor (Hz)	[50 Hz IEC] 50																														
[Nominal motor power] nPr	Nominal motor power given on the name plate (kW)	Dependent on type																														
[Nom Motor Voltage] unS	Nominal motor voltage given on the name plate (VAC)	Dependent on type																														
[Nom Motor Current] nCr	Nominal motor current given on the name plate (A)	Dependent on type																														
[Nominal Motor Freq] FrS	Nominal motor frequency given on the name plate (Hz)	50																														
[Nominal Motor Speed] nSP	Nominal motor speed given on the name plate (rpm)	Dependent on type																														
[Max Frequency] tFr	Maximum motor frequency (Hz)	60																														
[Motor Th Current] iTh	Thermal motor current given on the name plate (A)	Dependent on type																														
[2/3-Wire Control] tCC	Control command by 2-wire or 3-wire control	2C																														
2	<p>Perform the automatic motor measurement by setting parameter [Autotuning] tun to [Apply Autotuning] YES. Autotuning is performed immediately.</p> <p>NOTE: The motor has to be cold and stopped during performing the autotuning function.</p>																															

⚠ WARNING

UNEXPECTED MOVEMENT

Autotuning moves the motor in order to tune the control loops.

- Only start the system if there are no persons or obstructions in the zone of operation.

Failure to follow these instructions can result in death, serious injury, or equipment damage.

During autotuning, noise development and oscillations of the system are normal.

If [Autotuning Type] $tUNT$ is set to [Standard] STD , during autotuning, the motor makes small movements.

If [Autotuning Type] $tUNT$ is set to [Rotation] ROT , during autotuning, the motor runs at half of its nominal frequency.

⚠ WARNING

LOSS OF CONTROL

- If you modify the value of one or more motor parameters after having performed autotuning, the value of [Tune selection] $STUN$ is reset to [Default] TAB and you must re-perform autotuning.

Failure to follow these instructions can result in death, serious injury, or equipment damage.

Starting the Drive

Step	Action	✓
1	Ask for written authorization before commissioning.	
2	Switch the operating panel to panel control (therefore parameter [HMI cmd.] _{BMP} has to be set to [Stop] _{STOP}).	
3	Press the RUN key and check the direction of the motor rotation.	
4	Try different speeds and check the load of the drive.	
5	Before switching back to remote operation check the active reference values and control commands.	
6	Switch to remote operation and check the reaction of the control commands.	

Final Tasks

Step	Action	✓
1	Lock unallowed operating modes by adequate parameter adjustment.	
2	Save all application parameters.	
3	Read out all parameters using the PC and print out the whole list, if applicable.	

Maintenance

What's in This Chapter

Scheduled Servicing	61
Decommissioning	62
Additional Support	62

Scheduled Servicing

Servicing

⚠️⚠️ DANGER

HAZARD OF ELECTRIC SHOCK, EXPLOSION OR ARC FLASH

Read and understand the instructions in **Safety Information** chapter before performing any procedure in this chapter.

Failure to follow these instructions will result in death or serious injury.

⚠️ WARNING

INSUFFICIENT MAINTENANCE

Verify that the maintenance activities described below are performed at the specified intervals.

Failure to follow these instructions can result in death, serious injury, or equipment damage.

Adherence to the environmental conditions must be ensured during operation of the drive. In addition, during maintenance, verify and, if appropriate, correct all factors that may have an impact on the environmental conditions.

Maintenance has to be performed only by qualified and certified Schneider-Electric service personnel.

Always consider all local and national electrical code requirements as well as all other applicable regulations for maintenance intervals and verification.

Maintenance Activities

	Part concerned	Activity	Interval (1)
Overall condition	All parts such as housing, HMI, control block, connections, etc.	Perform a visual inspection	At least every year
Corrosion	Terminals, connectors, screws	Inspect and clean if required	
Dust	Terminals, fans, cabinet air inlets and air outlets, air filters of cabinet	Inspect and clean if required	
	Drives filter mats	Inspect Change	At least every year At least every 4 years
Cooling	Drives fan for power part and cabinet door fan	Replace the fans, see catalog and the instructions sheets on www.se.com .	Every 35,000 operating hours or every 6 years
Fastening	All screws for electrical and mechanical connections	Verify tightening torques	At least every year
<p>(1) Maximum maintenance intervals from the date of commissioning. Reduce the intervals between maintenance to adapt maintenance to the environmental conditions, the operating conditions of the drive, and to any other factor that may influence the operation and/ or maintenance requirements of the drive.</p>			

Diagnostic And Troubleshooting

Refer to the [ATV600 Programming Manual](#) or [ATV900 Programming Manual](#) available on www.se.com.

Spares and repairs

Serviceable products: Please refer to your Customer Care Center on:
www.se.com/CCC.

Decommissioning

Uninstall the Product

Observe the following procedure when uninstalling the product.

- Switch off all supply voltage. Verify that no voltages are present - refer to the Safety Information chapter, page 5.
- Remove all connection cables.
- Uninstall the product.

End of Life

The components of the product consist of different materials which can be recycled and which must be disposed of separately.

- Dispose of the packaging in compliance with all applicable regulations.
- Dispose of the product in compliance with all applicable regulations.

Refer to the [Green Premium section, page 16](#) for information and documents on environmental protection such as EoLI (End of Life instruction).

Additional Support

Customer Care Center

For additional support, you can contact our Customer Care Center on:
www.se.com/CCC.

Index



NHA37119.04

Schneider Electric
35 rue Joseph Monier
92500 Rueil Malmaison
France

+ 33 (0) 1 41 29 70 00

www.se.com

As standards, specifications, and design change from time to time,
please ask for confirmation of the information given in this publication.

© 2022 – Schneider Electric. All rights reserved.

NHA37119.04

Allivar drives

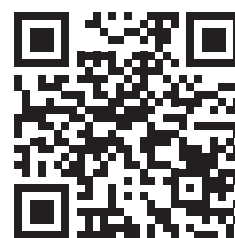

www.se.com/drives