

# Altivar Process

## ATV980 Regenerative Drive Systems

### Handbook

03/2025

NHA37117.03



# Legal Information

The information provided in this document contains general descriptions, technical characteristics and/or recommendations related to products/solutions.

This document is not intended as a substitute for a detailed study or operational and site-specific development or schematic plan. It is not to be used for determining suitability or reliability of the products/solutions for specific user applications. It is the duty of any such user to perform or have any professional expert of its choice (integrator, specifier or the like) perform the appropriate and comprehensive risk analysis, evaluation and testing of the products/solutions with respect to the relevant specific application or use thereof.

The Schneider Electric brand and any trademarks of Schneider Electric SE and its subsidiaries referred to in this document are the property of Schneider Electric SE or its subsidiaries. All other brands may be trademarks of their respective owner.

This document and its content are protected under applicable copyright laws and provided for informative use only. No part of this document may be reproduced or transmitted in any form or by any means (electronic, mechanical, photocopying, recording, or otherwise), for any purpose, without the prior written permission of Schneider Electric.

Schneider Electric does not grant any right or license for commercial use of the document or its content, except for a non-exclusive and personal license to consult it on an "as is" basis.

Schneider Electric reserves the right to make changes or updates with respect to or in the content of this document or the format thereof, at any time without notice.

**To the extent permitted by applicable law, no responsibility or liability is assumed by Schneider Electric and its subsidiaries for any errors or omissions in the informational content of this document, as well as any non-intended use or misuse of the content thereof.**

# Altivar Process Regenerative Drive Systems



4Q 

The customized solution for  
your drive

"Ready-to-use" Regenerative Drive Systems:

- + Developed on highest quality level
- + Manufactured according to your needs
- + Tested at full-load operating conditions
- + Pre-set appropriate to the design

## High efficient power regeneration

- + Lower heat losses compared to the classical AFE architecture
- + Dynamically adjusted DC link voltage
- + Reduced load of the mains
- + Enhanced motor lifetime due to decreased voltage load

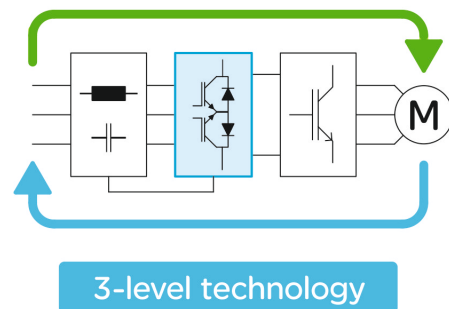

## Sophisticated motor control system

- + High overload capability
- + Especially good motor efficiency
- + Impressive robustness against load impacts
- + Excellent performance for all common motor types
- + Significant speed and torque accuracy with and without encoder feedback



- > Asynchronous motors
- > PM motors
- > Torque motors
- > Reluctance motors
- > Special motors like submersible pumps, sliding rotor motors,...

## Optimally equipped for safety-relevant applications

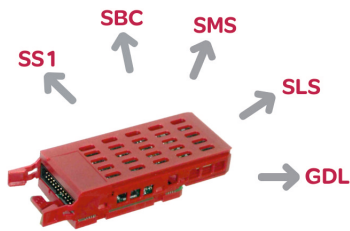

Support of all major safety functions:

- + SS1 (Safe Stop 1)
- + SBC (Safe Brake Control)
- + SMS (Safe Maximum Speed)
- + SLS (Safe Limited Speed)
- + GDL (Guard Door Locking)



## Extended connectivity

- + Integrated **Dual Ethernet** for simple wiring and increased availability
- + Dynamic **drive-to-drive communication** for multi-motor operation
- + Easy integration thanks to standardized FDT/DTM and ODVA technology
- + Easy access via PC, tablet or smartphone

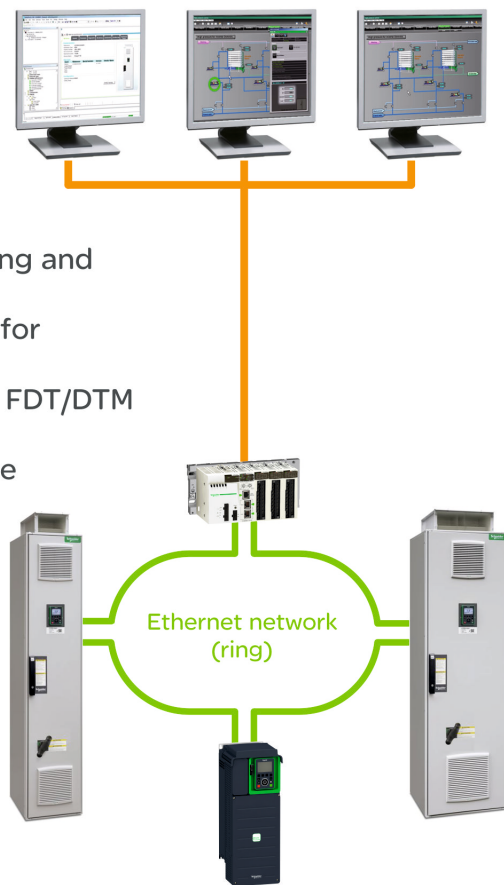

## Sophisticated service concept with QR code

- + **Modular design** allows easy logistics of spare parts
- + Optimized costs for maintenance due to **dynamic maintenance schedule** with integrated monitoring of the individual components
- + Simple exchange of power modules and fans
- + **Quick assistance** with dynamic QR codes and Customer Care App

# Table of Contents

About the document .....	7
Validity Note .....	8
Document Scope .....	9
Safety Information .....	10
Related Documents .....	16
Environmental Data Program .....	17
Terminology .....	18
Contact us .....	19
Drive Systems .....	20
Overview .....	21
ATV980 - Regenerative Drive Systems .....	22
Expandability .....	27
General Specification .....	30
Quality .....	31
Mains Conditions .....	36
Preliminary Instructions .....	40
ATV980●●●●4X1 .....	46
ATV980 Regenerative Drive Systems for 400 V Mains .....	47
General Technical Data .....	48
Protection Degree .....	50
Cooling concept .....	51
Maximum Ambient Temperature .....	52
Continuous Current and Overload at < 2 Hz .....	53
Specification .....	54
Circuit Diagram .....	83
Mains Connection .....	84
Motor Connection .....	88
Predefined Customizations .....	96
Wiring of the Control Terminals .....	98
Design/Position of the Individual Terminals .....	99
Control Block .....	102
Option "Logic and Analog I/O Card" .....	117
Option "Relay Output Card" .....	121
Option Terminals .....	123
Customizations .....	126
Enclosure Options .....	127
Control Options .....	132
I/O Expansion Cards .....	134
Communication Cards .....	136
Encoder Interface Modules .....	139
Functional Safety .....	141
Display Options .....	143
Motor Options .....	145
Mains Supply .....	149
Braking Option .....	152
EcoStruxure Asset Advisor .....	160
Documentation / Packaging .....	162



---

# About the document

## What's in This Part

Validity Note.....	8
Document Scope .....	9
Safety Information .....	10
Related Documents.....	16
Environmental Data Program .....	17
Terminology.....	18
Contact us .....	19

## Validity Note

Original instructions and information given in the present document have been written in English (before optional translation).

This documentation is valid for the Altivar Process Drive Systems.

The characteristics of the products described in this document are intended to match the characteristics that are available on [www.se.com](http://www.se.com). As part of our corporate strategy for constant improvement, we may revise the content over time to enhance clarity and accuracy. If you see a difference between the characteristics in this document and the characteristics on [www.se.com](http://www.se.com), consider [www.se.com](http://www.se.com) to contain the latest information.

# Document Scope

This document gives you an overview of the available Altivar Process Drive Systems. Additionally, you can choose from the detailed options to customize the Altivar Process Drive System to meet your system's specific needs.

# Safety Information

## What's in This Chapter

Qualification of Personnel ..... 11  
 Intended Use ..... 11  
 Product Related Information ..... 12

## NOTICE

Read these instructions carefully, and look at the equipment to become familiar with the device before trying to install, operate, service, or maintain it. The following special messages may appear throughout this documentation or on the equipment to warn of potential hazards or to call attention to information that clarifies or simplifies a procedure.



The addition of this symbol to a “Danger” or “Warning” safety label indicates that an electrical hazard exists which will result in personal injury if the instructions are not followed.



This is the safety alert symbol. It is used to alert you to potential personal injury hazards. Obey all safety messages that follow this symbol to avoid possible injury or death.

<b>⚠ DANGER</b>
<b>DANGER</b> indicates a hazardous situation which, if not avoided, <b>will result in</b> death or serious injury.

<b>⚠ WARNING</b>
<b>WARNING</b> indicates a hazardous situation which, if not avoided, <b>could result in</b> death or serious injury.

<b>⚠ CAUTION</b>
<b>CAUTION</b> indicates a hazardous situation which, if not avoided, <b>could result in</b> minor or moderate injury.

<b>NOTICE</b>
<b>NOTICE</b> is used to address practices not related to physical injury.

## PLEASE NOTE

Electrical equipment should be installed, operated, serviced, and maintained only by qualified personnel. No responsibility is assumed by Schneider Electric for any consequences arising out of the use of this material.

A qualified person is one who has skills and knowledge related to the construction and operation of electrical equipment and its installation, and has received safety training to recognize and avoid the hazards involved.

## Qualification of Personnel

Only appropriately trained persons who are familiar with and understand the contents of this manual and all other pertinent product documentation are authorized to work on and with this product. In addition, these persons must have received safety training to recognize and avoid hazards involved. These persons must have sufficient technical training, knowledge and experience and be able to foresee and detect potential hazards that may be caused by using the product, by changing the settings and by the mechanical, electrical and electronic equipment of the entire system in which the product is used. All persons working on and with the product must be fully familiar with all applicable standards, directives, and accident prevention regulations when performing such work.

## Intended Use

This product is intended for industrial use according to this manual.

The product may only be used in compliance with all applicable safety standard and local regulations and directives, the specified requirements and the technical data. The product must be installed outside the hazardous ATEX zone. Prior to using the product, you must perform a risk assessment in view of the planned application. Based on the results, the appropriate safety measures must be implemented. Since the product is used as a component in an entire system, you must ensure the safety of persons by means of the design of this entire system (for example, machine design). Any use other than the use explicitly permitted is prohibited and can result in hazards.

## Product Related Information

**Read and understand these instructions before performing any procedure with this device.**

### **DANGER**

#### **HAZARD OF ELECTRIC SHOCK, EXPLOSION OR ARC FLASH**

- Only appropriately trained persons who are familiar with and fully understand the contents of the present manual and all other pertinent product documentation and who have received all necessary training to recognize and avoid hazards involved are authorized to work on and with this device system.
- Installation, adjustment, repair and maintenance must be performed by qualified personnel.
- Verify compliance with all local and national electrical code requirements as well as all other applicable regulations with respect to grounding of all equipment.
- Only use properly rated, electrically insulated tools and measuring equipment.
- Do not touch unshielded components or terminals with voltage present.
- Prior to performing any type of work on the device system, block the motor shaft to prevent rotation.
- Insulate both ends of unused conductors of the motor cable.
- Do not short across the DC bus terminals or the DC bus capacitors or the braking resistor terminals.

**Failure to follow these instructions will result in death or serious injury.**

### **DANGER**

#### **HAZARD OF ELECTRIC SHOCK, EXPLOSION, OR ARC FLASH**

Before performing work on the device system:

- Disconnect all power, including external control power that may be present. Take into account that the circuit breaker or main switch does not de-energize all circuits.
- Place a "Do Not Turn On" label on all power switches related to the device system.
- Lock all power switches in the open position.
- Wait 15 minutes to allow the DC bus capacitors to discharge.
- Verify the absence of voltage. (1)

Before applying voltage to the device system:

- Verify that the work has been completed and that the entire installation cannot cause hazards.
- If the mains input terminals and the motor output terminals have been grounded and short-circuited, remove the ground and the short circuits on the mains input terminals and the motor output terminals.
- Verify proper grounding of all equipment.
- Verify that all protective equipment such as covers, doors, grids is installed and/or closed.

**Failure to follow these instructions will result in death or serious injury.**

(1) Refer to the Verify the Absence of Voltage section in the installation manual of the product.

Damaged products or accessories may cause electric shock or unanticipated equipment operation.

**⚠️⚠️ DANGER**

**ELECTRIC SHOCK OR UNANTICIPATED EQUIPMENT OPERATION**

Do not use damaged products or accessories.

**Failure to follow these instructions will result in death or serious injury.**

Contact your local Schneider Electric sales office if you detect any damage whatsoever.

This equipment has been designed to operate outside of any hazardous location. Only install this equipment in zones known to be free of a hazardous atmosphere.

**⚠️ DANGER**

**POTENTIAL FOR EXPLOSION**

Install and use this equipment in non-hazardous locations only.

**Failure to follow these instructions will result in death or serious injury.**

Your application consists of a whole range of different interrelated mechanical, electrical, and electronic components, the device being just one part of the application. The device by itself is neither intended to nor capable of providing the entire functionality to meet all safety-related requirements that apply to your application. Depending on the application and the corresponding risk assessment to be conducted by you, a whole variety of additional equipment is required such as, but not limited to, external encoders, external brakes, external monitoring devices, guards, etc. As a designer/manufacturer of machines, you must be familiar with and observe all standards that apply to your machine. You must conduct a risk assessment and determine the appropriate Performance Level (PL) and/or Safety Integrity Level (SIL) and design and build your machine in compliance with all applicable standards. In doing so, you must consider the interrelation of all components of the machine. In addition, you must provide instructions for use that enable the user of your machine to perform any type of work on and with the machine such as operation and maintenance in a safe manner. The present document assumes that you are fully aware of all normative standards and requirements that apply to your application. Since the device cannot provide all safety-related functionality for your entire application, you must ensure that the required Performance Level and/or Safety Integrity Level is reached by installing all necessary additional equipment.

## **▲ WARNING**

### **INSUFFICIENT PERFORMANCE LEVEL/SAFETY INTEGRITY LEVEL AND/OR UNINTENDED EQUIPMENT OPERATION**

- Conduct a risk assessment according to EN ISO 12100 and all other standards that apply to your application.
- Use redundant components and/or control paths for all critical control functions identified in your risk assessment.
- Verify that the service life of all individual components used in your application is sufficient for the intended service life of your overall application.
- Perform extensive commissioning tests for all potential error situations to verify the effectiveness of the safety-related functions and monitoring functions implemented, for example, but not limited to, speed monitoring by means of encoders, short circuit monitoring for all connected equipment, correct operation of brakes and guards.
- Perform extensive commissioning tests for all potential error situations to verify that the load can be brought to a safe stop under all conditions.

**Failure to follow these instructions can result in death, serious injury, or equipment damage.**

A specific application note NHA80973 is available on hoisting machines and can be downloaded on [se.com](http://se.com).

Product may perform unexpected movements because of incorrect wiring, incorrect settings, incorrect data or other errors.

## **▲ WARNING**

### **UNANTICIPATED EQUIPMENT OPERATION**

- Carefully install the wiring in accordance with the EMC requirements.
- Do not operate the product with unknown or unsuitable settings or data.
- Perform a comprehensive commissioning test.

**Failure to follow these instructions can result in death, serious injury, or equipment damage.**

## **▲ WARNING**

### **LOSS OF CONTROL**

- The designer of any control scheme must consider the potential failure modes of control paths and, for critical control functions, provide a means to achieve a safe state during and after a path failure. Examples of critical control functions are emergency stop, overtravel stop, power outage and restart.
- Separate or redundant control paths must be provided for critical control functions.
- System control paths may include communication links. Consideration must be given to the implications of unanticipated transmission delays or failures of the link.
- Observe all accident prevention regulations and local safety guidelines (1).
- Each implementation of the product must be individually and thoroughly tested for proper operation before being placed into service.

**Failure to follow these instructions can result in death, serious injury, or equipment damage.**

(1) For USA: Additional information, refer to NEMA ICS 1.1 (latest edition), Safety Guidelines for the Application, Installation, and Maintenance of Solid State Control and to NEMA ICS 7.1 (latest edition), Safety Standards for Construction and Guide for Selection, Installation and Operation of Adjustable-Speed Drive Systems.

The temperature of the products described in this manual may exceed 80 °C (176 °F) during operation.

## **▲ WARNING**

### **HOT SURFACES**

- Ensure that any contact with hot surfaces is avoided.
- Do not allow flammable or heat-sensitive parts in the immediate vicinity of hot surfaces.
- Verify that the product has sufficiently cooled down before handling it.
- Verify that the heat dissipation is sufficient by performing a test run under maximum load conditions.

**Failure to follow these instructions can result in death, serious injury, or equipment damage.**

## **NOTICE**

### **DESTRUCTION DUE TO INCORRECT MAINS VOLTAGE**

Before switching on and configuring the product, verify that it is approved for the mains voltage.

**Failure to follow these instructions can result in equipment damage.**

## Related Documents

Use your tablet or your PC to quickly access detailed and comprehensive information on all our products on [www.se.com](http://www.se.com).

The internet site provides the information you need for products and solutions:

- The whole catalog for detailed characteristics and selection guides,
- The CAD files to help design your installation, available in over 20 different file formats,
- All software and firmware to maintain your installation up to date,
- A large quantity of White Papers, Environment documents, Application solutions, Specifications... to gain a better understanding of our electrical systems and equipment or automation,
- And finally all the User Guides related to your drive, listed below:

Title of Documentation	Catalog Number
Leaflet: Altivar Process customized drive solutions	998-19696726 (English)
Catalog: Variable speed drives Altivar Process ATV900	DIA2ED2150601EN (English), DIA2ED2150601FR (French)
ATV960 Handbook	NHA37114 (German), NHA37115 (English)
ATV980 Handbook	NHA37116 (German), NHA37117 (English)
ATV990 Handbook	NHA37143 (German), NHA37145 (English)
Drive Systems – Installation manual	NHA37118 (German), NHA37119 (English), NHA37121 (French), NHA37122 (Spanish), NHA37123 (Italian), NHA37124 (Dutch), NHA37126 (Polish), NHA37127 (Portuguese), NHA37129 (Turkish), NHA37130 (Chinese)
ATV6●● & ATV9●● ATEX manual	NVE42416 (English)
Altivar Application Note for Hoisting	NHA80973 (English)
ATV9●● Programming manual	NHA80757 (English), NHA80758 (French), NHA80759 (German), NHA80760 (Spanish), NHA80761 (Italian), NHA80762 (Chinese)
ATV991, ATV992 Programming manual	QGH33275 (English)
ATV9●● Modbus serial link manual	NHA80939 (English)
ATV9●● Ethernet embedded manual	NHA80940 (English)
ATV9●● PROFIBUS DP manual (VW3A3607)	NHA80941 (English)
ATV9●● DeviceNet manual (VW3A3609)	NHA80942 (English)
ATV9●● PROFINET manual (VW3A3627)	NHA80943 (English)
ATV9●● CANopen manual (VW3A3608, 618, 628)	NHA80945 (English)
ATV9●● EtherCAT manual (VW3A3601)	NHA80946 (English)
ATV9●● POWERLINK manual (VW3A3619)	PHA99693 (English)
ATV9●● Communication parameters addresses	NHA80944 (English)
ATV9●● Embedded safety function manual	NHA80947 (English)
ATV6●● & ATV9●● ATEX manual	NVE42416 (English)
SoMove: FDT	SoMove_FDT (English, French, German, Spanish, Italian, Chinese)
Altivar Process ATV9●● DTM	ATV9xx_DTM_Library_EN (English), ATV9xx_DTM_Library_FR (French), ATV9xx_DTM_Library_DE (German), ATV9xx_DTM_Library_SP (Spanish), ATV9xx_DTM_Library_IT (Italian), ATV9xx_DTM_Library_CN (Chinese),
Recommended Cybersecurity Best Practices	CS-Best-Practices-2019-340 (English)

You can download these technical publications and other technical information from our website at [www.se.com](http://www.se.com).

# Environmental Data Program



## Next-level transparency for better-informed product choices

The **Environmental Data Program** is a framework for how we measure, categorize, and compare the environmental attributes and footprint of our products.

Using a rigorous, fact-based methodology, the program provides environmental data from across the product lifecycle.

With this transparent, verified data, customers and partners are empowered to make conscious environmental choices and accurately evaluate and report on sustainability performance.

All our hardware offers have an associated environmental data available on se.com product pages.

Carbon footprint (kg CO<sub>2</sub> eq) **91745**

One methodology is used to calculate the carbon footprint of all our products to enable simple comparison.



Learn more about the [Environmental Data Program](#)

**Use Better:** How sustainable a product is, including environmental footprint, materials and substances, packaging, and energy efficiency.

<b>Recycled Cardboard Packaging</b>	<b>Yes</b>
<b>REACH and RoHS compliant</b>	<b>Yes</b>

**Use Longer:** How a product's life time can be effectively extended in terms of reparability and updatability.

<b>Firmware updatable</b>	<b>Yes</b>
<b>Repairability Index</b>	<b>Rating "A"</b>

**Use Again:** How a product can be reused, from dismantling and remanufacturing to recyclability and manufacturer take back.

<b>Recyclable potential</b>	<b>77%</b>
<b>Take-back</b>	<b>Yes</b>

# Terminology

The technical terms, terminology, and the corresponding descriptions in this manual normally use the terms or definitions in the relevant standards.

In the area of drive systems this includes, but is not limited to, terms such as **error**, **error message**, **failure**, **fault**, **fault reset**, **protection**, **safe state**, **safety function**, **warning**, **warning message**, and so on.

Among others, these standards include:

- IEC 61800 series: Adjustable speed electrical power drive systems
- IEC 61508 Ed.2 series: Functional safety of electrical/electronic/programmable electronic safety-related
- EN 954-1 Safety of machinery - safety-related parts of control systems
- EN 61439 series: Low-voltage switchgear and controlgear assemblies
- ISO 13849-1 & 2 Safety of machinery - safety related parts of control systems
- IEC 61158 series: Industrial communication networks - Fieldbus specifications
- IEC 61784 series: Industrial communication networks - Profiles
- IEC 60204-1: Safety of machinery - Electrical equipment of machines – Part 1: General requirements

In addition, the term **zone of operation** is used in conjunction with the description of specific hazards, and is defined as it is for a **hazard zone** or **danger zone** in the EC Machinery Directive (2006/42/EC) and in ISO 12100-1.

## Contact us

Select your country on [www.se.com/contact](http://www.se.com/contact).

Schneider Electric Industries SAS

Head Office

35, rue Joseph Monier

92500 Rueil-Malmaison

France

# Drive Systems

## What's in This Part

Overview .....	21
ATV980 - Regenerative Drive Systems .....	22
Expandability .....	27

# Overview

<b>Market Segment</b>	<b>Water and waste water</b> <b>Oil &amp; gas</b> <b>Mining, minerals &amp; metals</b> <b>Food &amp; beverage</b>
-----------------------	--



<b>Drive Systems</b>	Frequency inverter as enclosure unit for speed control of asynchronous and synchronous motors.	
<b>Brief description</b>	Enclosure unit, alternatively in the standard design, with predefined customizations or as individual customer solution	Enclosure unit ready for regeneration, alternatively in the standard design, with predefined customizations or as individual customer solution
<b>Special features</b>	High Performance Drive Systems with high overload capability and sophisticated motor control system	Regenerative Drive Systems with highly efficient 4Q technology for speed control in both energy directions
<b>Protection degree</b>	IP23 standard design of the enclosure IP54 optional design of the enclosure	
<b>Power range</b>	110 / 90 up to 800 / 630 kW	
<b>Voltage ranges</b>	<ul style="list-style-type: none"> <li>• 3 AC 380 V -10 % ... 415 V +6 %</li> <li>• 3 AC 400 V -10 % ... 415 V +10 %</li> </ul>	<ul style="list-style-type: none"> <li>• 3 AC 440 V ±10 %</li> <li>• 3 AC 480 V ±10 %</li> </ul>
<b>Mains frequency</b>	50/60 Hz +/- 5 %	
<b>Output frequency</b>	0.1...599 Hz	
<b>Control method</b>	Asynchronous motor: Constant load torque (open/closed loop), variable load torque (open/closed loop), energy saving Synchronous motor: PM (permanent magnet) motor (open/closed loop)	
<b>Interfaces</b>	Operating panel in the enclosure door, control terminals inside the enclosure, control terminals can be extended, fieldbus connection via Ethernet or Modbus, saving the parameters via USB interface at the keypad	
<b>References</b>	<b>ATV960●●●●●X1</b>	<b>ATV980●●●●●X1</b>
<b>Configuration tool</b>	Fully configurable with Altivar Process Drive Systems Configurator: Altivar Process Drive Systems Configurator Tool.	
<b>Further reading</b>	You can find detailed information in the "Altivar Process ATV960 Handbook" and on <a href="http://www.se.com">www.se.com</a> .	You will find detailed information in this document.

# ATV980 - Regenerative Drive Systems

## What's in This Chapter

General Information ATV980 .....	23
Enclosure Design 400 V .....	25

## General Information ATV980



Regenerative Drive Systems as enclosure unit for speed control of asynchronous and synchronous motors in both energy directions.

### Concept

The ATV980 Regenerative Drive Systems increase the efficiency by feeding back the drive energy to the mains.

An absolutely new developed concept based on a 3-level technology allows the full energy flow in both directions and reduces the total harmonic distortion THD(i) to a value less than 5 % at the same time.

During the development of the enclosure system special attention was paid to the "simplicity" of installation and during operation. The result is an enclosure ready to connect for drives where also generator operating state can occur. So it is an adequate 4-quadrant drive with shock-free change from motor operation to generator operation.

The modular system concept with more than 80 selectable options makes it possible to adapt the enclosure unit optimally to the individual requests. The completely tested enclosure ready to connect allows a quick installation and commissioning of the drive.

### Basic equipment

The basic equipment contains active infeed modules and their filter components as well as frequency inverter modules, semiconductor fuses, a main switch, a dv/dt filter choke (from 200 kW) for protection of the motor and spacious mains and motor bars for connection of the power cables. The design is based on the standard enclosure system PanelSeT SFN with an graphical operating panel integrated into the enclosure door.

The control is located on a spacious control panel. It provides compact dimensions, nevertheless it is enough space for additional extensions and accessibility in case of maintenance.

### Altivar Process Drive Systems Configurator

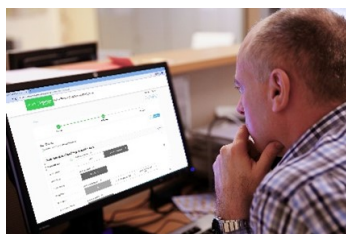

All-in-one tool to configure individual Drive Systems. It allows quick customization of Configured Drive Systems (CTO) to meet your specific requirements. Thanks to pre-defined options, the CTO variant allows a significant reduction of the production time for individually adapted drives, ready to connect.

- 4 ranges ATV660, ATV680, ATV960, ATV980
- 90 ... 800 kW @400 V
- 110 ... 900 kW @480V
- Tested, validated, documented, and pre-set parameters

[Click here to start the Altivar Process Drive Systems Configurator Tool.](#)

**Device features**

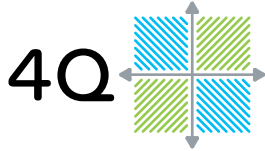

**Simple use**

The ATV980 drives and brakes each motor without any additional effort. So this new 4Q technology is the perfect solution for drives where also generator operating state can occur. Thereby more complex multi-drive solutions with DC bus can be avoided.

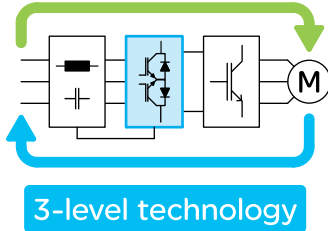

**Energy savings by high efficient power regeneration**

The 3-level technology inside the active mains rectifier and the dynamically adapted DC link voltage make an efficient energy flow from and to the supplying mains possible. So the ATV980 makes an essential contribution to saving electrical energy.

**Reduced load of the mains by 3-level concept**

In comparison with the classic circuit structure of active mains rectifiers, the 3-level technology allows an increase of the switching frequency and the current load is reduced at the same time. This new technology reaches a total harmonic distortion THD(i) below 2 % and thus fulfills the requirements according to IEEE 519 of THD(i) < 5 % also in case of distorted mains. Additionally, the  $\cos \Phi \approx 1$  in each load situation helps to reduce the load of the mains.

# Enclosure Design 400 V

ATV980 - General technical data			
Mains voltage	<ul style="list-style-type: none"> <li>• 3 AC 380 V -10 % ... 415 V +6 %</li> <li>• 3 AC 400 V -10 % ... 415 V +10 %</li> <li>• 3 AC 440 V ±10 %</li> <li>• 3 AC 480 V ±10 %</li> </ul> 50/60 Hz ±5 % for TT, TN-C or TN-S Other voltages and mains topologies on request.		
Maximum current	Normal duty (ND): 120 % for 60 s per 10 minutes Heavy duty (HD): 150 % for 60 s per 10 minutes		
Ambient temperature	-10...+50 °C (below 0 °C with additional enclosure heating, above +40 °C with derating) You will find further information at chapter <a href="#">Maximum Ambient Temperature</a> , page 52.		
Standard equipment	Enclosure system PanelSeT SFN in RAL 7035, protection degree IP23, graphical operating panel in the enclosure door, Regenerative Drive System with active mains rectifier for energy regeneration, mains and motor terminals, cable entry from bottom		
Interfaces	Pluggable control terminals, fieldbus connection via Ethernet or Modbus		
Possible customizations	<table border="0"> <tr> <td> <ul style="list-style-type: none"> <li>• Braking unit BUO</li> <li>• Increased protection degree IP54</li> <li>• Enclosure plinth for basic device</li> <li>• Connection enclosure cable from top/bottom</li> <li>• Enclosure lighting</li> <li>• Enclosure heating</li> <li>• Key switch "local/remote"</li> <li>• Ethernet port on front door</li> <li>• Digital and analog I/O card</li> <li>• Relay output card</li> <li>• Communication cards for various fieldbus systems</li> <li>• Encoder interface modules</li> <li>• STO - SIL 3 Stop category 0 or 1</li> <li>• Front display module (FDM)</li> <li>• Modified wiring colors</li> <li>• Remote monitoring</li> <li>• Seaworthy packaging</li> <li>• Differing mains voltages</li> <li>• Design without main switch</li> </ul> </td> <td> <ul style="list-style-type: none"> <li>• Increased short-circuit strength (100 kA)</li> <li>• Indicator lamps on front door</li> <li>• Motor temperature monitoring</li> <li>• Bearing temperature monitoring</li> <li>• dv/dt filter choke</li> <li>• Motor heating</li> <li>• Circuit breaker</li> <li>• Undervoltage coil for circuit breaker 230 V</li> <li>• Motor for circuit breaker 230 V</li> <li>• Safety labels in local language</li> <li>• Air intake from back</li> <li>• Differing enclosure colors</li> <li>• Customized documentation</li> <li>• Customized labeling</li> <li>• Design for IT mains</li> <li>• Motor contactor</li> <li>• ...</li> </ul> </td> </tr> </table>	<ul style="list-style-type: none"> <li>• Braking unit BUO</li> <li>• Increased protection degree IP54</li> <li>• Enclosure plinth for basic device</li> <li>• Connection enclosure cable from top/bottom</li> <li>• Enclosure lighting</li> <li>• Enclosure heating</li> <li>• Key switch "local/remote"</li> <li>• Ethernet port on front door</li> <li>• Digital and analog I/O card</li> <li>• Relay output card</li> <li>• Communication cards for various fieldbus systems</li> <li>• Encoder interface modules</li> <li>• STO - SIL 3 Stop category 0 or 1</li> <li>• Front display module (FDM)</li> <li>• Modified wiring colors</li> <li>• Remote monitoring</li> <li>• Seaworthy packaging</li> <li>• Differing mains voltages</li> <li>• Design without main switch</li> </ul>	<ul style="list-style-type: none"> <li>• Increased short-circuit strength (100 kA)</li> <li>• Indicator lamps on front door</li> <li>• Motor temperature monitoring</li> <li>• Bearing temperature monitoring</li> <li>• dv/dt filter choke</li> <li>• Motor heating</li> <li>• Circuit breaker</li> <li>• Undervoltage coil for circuit breaker 230 V</li> <li>• Motor for circuit breaker 230 V</li> <li>• Safety labels in local language</li> <li>• Air intake from back</li> <li>• Differing enclosure colors</li> <li>• Customized documentation</li> <li>• Customized labeling</li> <li>• Design for IT mains</li> <li>• Motor contactor</li> <li>• ...</li> </ul>
<ul style="list-style-type: none"> <li>• Braking unit BUO</li> <li>• Increased protection degree IP54</li> <li>• Enclosure plinth for basic device</li> <li>• Connection enclosure cable from top/bottom</li> <li>• Enclosure lighting</li> <li>• Enclosure heating</li> <li>• Key switch "local/remote"</li> <li>• Ethernet port on front door</li> <li>• Digital and analog I/O card</li> <li>• Relay output card</li> <li>• Communication cards for various fieldbus systems</li> <li>• Encoder interface modules</li> <li>• STO - SIL 3 Stop category 0 or 1</li> <li>• Front display module (FDM)</li> <li>• Modified wiring colors</li> <li>• Remote monitoring</li> <li>• Seaworthy packaging</li> <li>• Differing mains voltages</li> <li>• Design without main switch</li> </ul>	<ul style="list-style-type: none"> <li>• Increased short-circuit strength (100 kA)</li> <li>• Indicator lamps on front door</li> <li>• Motor temperature monitoring</li> <li>• Bearing temperature monitoring</li> <li>• dv/dt filter choke</li> <li>• Motor heating</li> <li>• Circuit breaker</li> <li>• Undervoltage coil for circuit breaker 230 V</li> <li>• Motor for circuit breaker 230 V</li> <li>• Safety labels in local language</li> <li>• Air intake from back</li> <li>• Differing enclosure colors</li> <li>• Customized documentation</li> <li>• Customized labeling</li> <li>• Design for IT mains</li> <li>• Motor contactor</li> <li>• ...</li> </ul>		
Standards	CE, EAC, RCM, ATEX, IEEE 519 (THDi < 5 %), RFI filter for second "industrial environment" C3 integrated		

Type	Size	Motor rating (ND / HD)	Output current (ND / HD)	Dimensions		
				Width	Depth <sup>(1)</sup>	Height
ATV980C11●4X1	1a	110 kW / 90 kW	211 A / 173 A	600 mm	600 mm	2150 mm
ATV980C13●4X1		132 kW / 110 kW	250 A / 211 A	600 mm	600 mm	2150 mm
ATV980C16●4X1		160 kW / 132 kW	302 A / 250 A	600 mm	600 mm	2150 mm
ATV980C20●4X1	2a	200 kW / 160 kW	370 A / 302 A	1000 mm	600 mm	2150 mm
ATV980C25●4X1		250 kW / 200 kW	477 A / 370 A	1000 mm	600 mm	2150 mm
ATV980C31●4X1		315 kW / 250 kW	590 A / 477 A	1000 mm	600 mm	2150 mm
ATV980C35●4X1	3a	355 kW / 280 kW	660 A / 520 A	1600 mm	600 mm	2150 mm
ATV980C40●4X1		400 kW / 315 kW	730 A / 590 A	1600 mm	600 mm	2150 mm
ATV980C45●4X1		450 kW / 355 kW	830 A / 660 A	1600 mm	600 mm	2150 mm
ATV980C50●4X1		500 kW / 400 kW	900 A / 730 A	1600 mm	600 mm	2150 mm
ATV980C56●4X1	4a	560 kW / 450 kW	1020 A / 830 A	2000 mm	600 mm	2150 mm
ATV980C63●4X1		630 kW / 500 kW	1140 A / 900 A	2000 mm	600 mm	2150 mm
ATV980C71●4X1	5a	710 kW / 560 kW	1260 A / 1020 A	2600 mm	600 mm	2150 mm
ATV980C80●4X1		800 kW / 630 kW	1420 A / 1140 A	2600 mm	600 mm	2150 mm
<b>(1)</b> Total depth including door handle and switch handle: 664 mm						

# Expandability

## What's in This Chapter

Introduction.....	28
Predefined Customizations .....	28
Individual Customizations .....	28
Type designation .....	29

## Introduction

The Altivar Process Drive Systems are the result of our many years of experience in the field of electronic drives. Moreover we provide especially designed expansion options for a various range of applications. Our worldwide, certified manufacturing sites and the local engineering teams allow a global offer.

## Predefined Customizations



Due to the predefined customizations the Altivar Process Drive System can be adapted easily and quick to the customer requirements. Besides, this allows minimal delivery time for an individually adapted enclosure ready to connect.

Certainly the Altivar Process Drive Systems can be ordered also in the basic design, which is already extensive equipped, without any customization.

Predefined customizations are:

- Braking unit BUO
- Increased protection degree IP54
- Enclosure plinth for basic device
- Connection enclosure cable from top/ bottom
- Enclosure lighting
- Enclosure heating
- Key switch "local/remote"
- Ethernet port on front door
- Digital and analog I/O card
- Relay output card
- Communication cards for various fieldbus systems
- Encoder interface modules
- STO - SIL 3 Stop category 0 or 1
- Front display module (FDM)
- Indicator lamps on front door
- Motor temperature monitoring
- Bearing temperature monitoring
- dv/dt filter choke
- Motor heating
- Circuit breaker
- Undervoltage coil for circuit breaker
- Motor for circuit breaker
- Safety labels in local language
- Modified wiring colors
- Remote monitoring
- Seaworthy packaging
- Differing mains voltages
- Design without main switch
- Increased short-circuit strength (100 kA)
- Air intake from back
- Differing enclosure colors
- Customized documentation
- Customized labeling
- Design for IT mains
- Motor contactor
- Integrated control functions
- ...

## Individual Customizations



Due to our substantial know-how and the high flexibility in performing projects, it is possible to realize unique system solutions. They are individually adapted to the customers demands.

Typical customizations:

- Multi drives (several frequency inverters in an enclosure composition)
- Differing cooling system
- Different enclosure system
- Differing dimensions
- ...

## Type designation

The type designation of the Altivar Process Drive Systems consists of several points of signs (characters and figures). The meaning of each point is illustrated in the following example.

		ATV	980	C16	Q4	X1
<b>Product</b>	<b>Description</b>					
ATV	Altivar					
<b>Segments</b>						
980	Regenerative Drive Systems					
<b>Drive power</b>						
C11...C80	110 / 90 kW ... 800 / 630 kW					
<b>Mains voltage</b>						
Q4	3 AC 380 V -10 %...415 V +6 % (+10 %)					
R4	3 AC 440 V ±10 %					
T4	3 AC 480 V ±10 %					
<b>Design variant</b>						
X1	Europe CE					
X3	China CCC					

# General Specification

## What's in This Part

Quality.....	31
Mains Conditions .....	36
Preliminary Instructions .....	40

# Quality

## What's in This Chapter

Overview .....	32
System concept ATV980 .....	32
CE Marking .....	33
Installation Regulations .....	33
Safety of Machinery .....	34
EMC Product Standard for Power Device Systems EN 61800-3 .....	34
Use In Industrial Environment .....	35

# Overview

Altivar frequency inverters use modern components and solutions for the control of asynchronous three-phase motors and synchronous three-phase motors. This enables an extremely compact design and user-friendly device features.

The ATV980 includes an active input bridge, leads a sinusoidal mains current and increases the efficiency by feeding back the drive energy to the mains (4Q operation).

State-of-the-art components, a new control concept as well as a top-quality filter module reduce the total harmonic distortion THD(i) of the frequency inverter to a value less than 2...5 % and by this way it fulfills the requirements according to the recommendations in IEEE 519 to reduce the current harmonics in the mains.

Also in case of operation with partial load (from 30 % P<sub>n</sub>) the ATV980 leads a sinusoidal mains current with a power factor cos Phi ≈ 1.

Our high degree of quality awareness ranges from the basic requests in the product specification over the development of the cooling system, of the mechanical design, of the electrical circuit diagram and the individual functions up to the production of the device. This process quality level is also long-term guaranteed by means of the corresponding quality assurance systems in the individual business processes and is certified every year by independent authorities according to DIN EN ISO 9001.

The Altivar Process Drive Systems fulfil the relevant international standards and regulations.

# System concept ATV980

Altivar Process Drive Systems are manufactured according to the selected design (basic device and options) and are delivered as a drive unit ready to connect. They include the functionally necessary components.

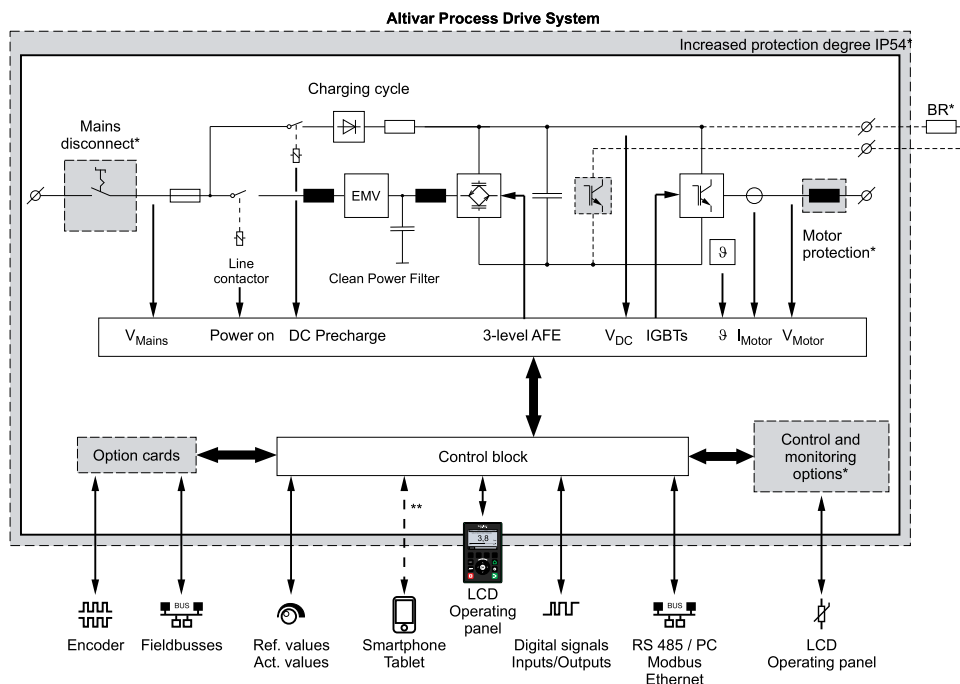

\* Optionally selectable  
 \*\* With optional WIFI module (TCSEGWB13FA0)

Depending on the local conditions and the requests on the drive the basic design can be supplemented by options. Options for the power path, options for control and operation as well as mechanical options are available. They are all integrated into the enclosure unit but they may cause a change of dimensions.

## CE Marking

The frequency inverters have a CE marking on the rating plate. However, to achieve the corresponding limits it is necessary to observe the installation regulations, superior and regional standards and directives as well as the directives listed below.

All devices and drives of the electric drive engineering may cause electromagnetic interferences and otherwise they may be influenced by such interferences. Therefore, they are subject to the **EMC directive 2014/30/EC**.

The frequency inverters have an operating voltage which is clearly in the range of 50...1000 V AC or 75...1500 V DC. Therefore, they are also subject to the **Low Voltage Directive 2014/35/EC**.

Because of the EMC filters which are built into the frequency inverters they are in conformity with **EN 61800-3** and **EN 61800-5-1**.

Frequency inverters are not considered as stand-alone machines according to the Machinery Directive 2006/42/EC. They have to be accounted as component of the closed functional safety system.

### Limit values

This product meets the EMC requirements according to the standard IEC 61800-3 if the measures described in this manual are implemented during installation.

If the selected composition (product itself, mains filter, other accessories and measures) does not meet the requirements of category C1, the following information applies as it appears in IEC 61800-3:

<b>▲ WARNING</b>
<b>RADIO INTERFERENCE</b>
In a domestic environment this product may cause radio interference in which case supplementary mitigation measures may be required.
<b>Failure to follow these instructions can result in death, serious injury, or equipment damage.</b>

## Installation Regulations

- The frequency inverters have a RFI filter for grounded mains built-in.
- Take care of good HF connection between motor cable screen and filter.
- Use of shielded motor cables, proper connection of the motor cables on both ends or proper laying in a metallic, closed and interconnected cable conduit.
- In case of high motor cable lengths a corresponding dv/dt filter choke is required.
- Use shielded control cables and connect them correctly.
- Ground the frequency inverter for human protection.
- Consider the protective separation (PELV) when preparing signal wires and coupling relays.
- Lay the motor cables separate from other cables, especially from the signal wires.

**NOTE:** Further information is given in the installation manual.

## Safety of Machinery

For the functional safety and stop categories the function "Safe Torque Off (STO)" has been integrated. So an optimal adaptation of the drive to the required safety category for the machine is possible.

**NOTE:** You will find further information about this function in chapter Safe Torque Off (STO), page 142.

For all selectable safety options the implementation of external safety-relevant contacts is provided. So the Altivar Process does not act as a closed functional safety system in terms of the Machine directive and safety standards EN/IEC 61508, ISO 13849-1 and NF EN 62061. It has to be accounted as component in any case.

## EMC Product Standard for Power Device Systems EN 61800-3

For frequency inverter devices the product standard EN/IEC 61800-3 edition 1 and 2 appeared. It has first priority over the existing general standards (generic standards). If a device is installed into another device for which a separate EMC product standard exists, then this standard applies.

The aim of the **EMC directive 2014/30/EEC** is the ability of electric and electronic installations to operate satisfactorily in their electromagnetic environment without influencing the environment or other loads therein.

Therefore, the PDS (Power Device Systems) product standard contains both limits for admissible interferences and requirements for the necessary interference resistance.

The power device standard EN 61800-3 covers the complete device from the mains supply to the motor shaft.

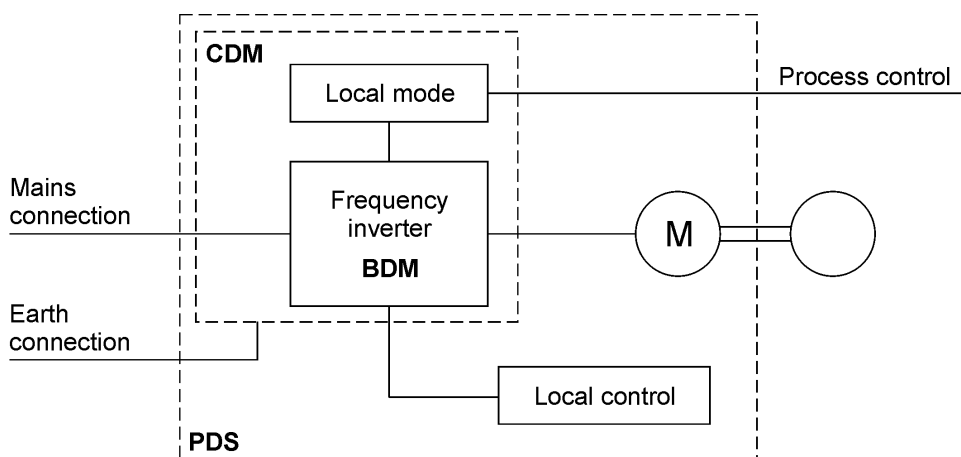

- BDM: Base-Device-Module**      Basic device consisting of the power part and the control electronics (e.g. frequency inverter - built-in unit)
- CDM: Complete-Device-Module**      Device modules consisting of BDM (basic device) and extensions, if existing (e.g. enclosure including main switch, circuit breaker, line contactor, filter components, power terminals, ...)
- PDS: Power-Device-System**      Device system consisting of CDM (device module) and motor, motor cable, local control, power transformer, ... (e.g. the complete electric device of a machine)

The differentiation in respect of the sales method and the range of use is essential for the handling of frequency inverters.

# Use In Industrial Environment

The standard refers to these application areas as "second environment". These are areas which are separated from the public mains by means of an own transformer.

The user has to take care that the suppression components recommended by the manufacturer are used and that the introductions of the manufacturer are observed. Moreover, the user has to take care that strong interferences do not couple into neighboring low-voltage mains.

If the neighboring mains is a public mains with residential areas, the limits 66-56/56/60 dB(μV) quasi-peak apply. In case of industrial mains the higher limits 79/73/73 dB(μV) quasi-peak can be used.

Furthermore, it is necessary to enhance the suppression of interferences if other devices are influenced. The operator of the plant is responsible for this improvement.

The limits for immunity are much stricter because they are based on a generally higher level of interferences.

### Category C3

Use in industrial environments

Limits for interferences	Line-conducted interferences	Radiation
For devices with a size ≤ 100 A the admissible limits for interferences are 100/86/90-70 dB(μV) quasi-peak and 50/60 dB(μV/m) at a distance of 10 m (class A group 2).	<p><b>dBμV (QP)</b></p> <p>0.15 0.5 5 30 MHz</p>	<p><b>dBμV/m (QP)</b></p> <p>30 230 1000 MHz</p>
For devices with a size > 100 A the admissible limits for interferences are 130/125/115 dB(μV) quasi-peak and 50/60 dB(μV/m) at a distance of 10 m (class A group 2).	<p><b>dBμV (QP)</b></p> <p>0.15 0.5 5 30 MHz</p>	<p><b>dBμV/m (QP)</b></p> <p>30 230 1000 MHz</p>

### Category C4

Use in industrial environments for devices > 1000 V or > 400 A

For these devices are no limits defined. An EMC concept has to be compiled within project planning.

### IT mains

In case of non-grounded mains it is usually not possible to keep the limits. Filter capacitors make detection of insulation faults difficult and thus they interfere with the concept of a floating power supply. However, filters that are developed especially for IT mains can be used because they also cause a high reduction of the conducted interferences in non-grounded mains.

**NOTE:** The basic requirements for compliance with the relevant limits are the observance and compliance of the installation requirements and a correct customization of the Device System.

# Mains Conditions

## What's in This Chapter

Mains Voltage .....	37
Non-grounded Mains .....	37
Radio Interferences .....	38
Mains Impedance / Short-circuit Current .....	38
Switching Rate .....	38

## Mains Voltage

The Altivar Process Drive Systems are designed for standard industrial mains TT and TN with following mains voltage:

- 3 AC 380 V -10 % ... 415 V +6 %
- 3 AC 400 V -10 % ... 415 V +10 %
- 3 AC 440 V  $\pm$ 10 %
- 3 AC 480 V  $\pm$ 10 %

**NOTE:** Other voltages and the use in IT mains or "Corner grounded networks" are available on request.

The mains voltage must comply with the requirements according to IEC 60038 and EN 50160:

- Unbalance between phases: < 2 %
- Total harmonic factor THD(v): < 10 %
- Maximum single harmonic: < 5 %

### NOTICE

#### DESTRUCTION DUE TO INCORRECT MAINS VOLTAGE

Before switching on and configuring the product, verify that it is approved for the mains voltage.

**Failure to follow these instructions can result in equipment damage.**

#### Undervoltage behavior

In case of short-time mains voltage drops outside the specified tolerance, operation is still possible.

If the mains voltage does not return within the specified time, an undervoltage shut-down occurs.

Mains undervoltage	Restriction
-10 % of nominal voltage	Starting the drive and continuous operation possible <sup>(1)</sup>
-15 % of nominal voltage	Starting the drive and operation <sup>(1)</sup> for 10 s per 100 s possible
-20 % of nominal voltage	Operation <sup>(1)</sup> for less than 1 s possible
-30 % of nominal voltage	Operation <sup>(1)</sup> for less than 0.5 s possible
<b>(1)</b> With nominal current	

## Non-grounded Mains

The Altivar Process Drive Systems can be prepared for the use in non-grounded mains (IT mains or "Corner grounded networks").

## Radio Interferences

The Altivar Process Drive Systems include a radio frequency interference filter as standard. This filter fulfils the requirements for category "C3 – industrial environments" according to EN/IEC 61800-3 (in the past: EN 55011 class A group 2).

### Limit values

This product meets the EMC requirements according to the standard IEC 61800-3 if the measures described in this manual are implemented during installation.

If the selected composition (product itself, mains filter, other accessories and measures) does not meet the requirements of category C1, the following information applies as it appears in IEC 61800-3:

### **▲ WARNING**

#### **RADIO INTERFERENCE**

In a domestic environment this product may cause radio interference in which case supplementary mitigation measures may be required.

**Failure to follow these instructions can result in death, serious injury, or equipment damage.**

## Mains Impedance / Short-circuit Current

The Altivar Process Drive Systems are designed considering a maximal and minimal permitted mains short-circuit current of the supply (values see "Technical data" of the respective frequency inverter).

These frequency inverters can be designed for higher mains short-circuit currents on request. You will find information about the short-circuit protection at chapter Mains Connection, page 84.

## Switching Rate

Altivar Process Drive Systems are equipped with a main switch for disconnecting the applied mains voltage.

In case of frequent start/stop requests it is recommended to realize them by means of the digital control inputs (or via a serial bus) directly to the electronics of the inverter.

Optionally the mains separation can be realized by a circuit breaker with motor.

**NOTE:** By means of the certificated control inputs  $\overline{\text{STOA}}$  and  $\overline{\text{STOB}}$  a "Safe Torque Off" of the drive is considering the safety category according to ISO 13849-1 (and IEC/EN 61800-5-2). Disconnecting the mains supply or the motor is therefore not required.

Inverter control	Switching rate ATV980
Mains voltage switched external	Max. 60 switching operations per hour
Mains voltage switched internal: <ul style="list-style-type: none"> <li>• Main switch (standard)</li> <li>• Circuit breaker (option)</li> <li>• Circuit breaker with motor (option)</li> </ul>	Max. 10 switching operations per hour Max. 10,000 switching operations total
Start / Stop requests via digital inputs with active energy saving function "Stop and Go" <sup>(1)</sup>	Max. 60 switching operations per hour
Start / Stop requests via digital inputs without energy saving function "Stop and Go" <sup>(1)</sup>	Arbitrary
Release / Lock via STO inputs with active energy saving function "Stop and Go" <sup>(1)</sup>	Max. 60 switching operations per hour
Release / Lock via STO inputs without energy saving function "Stop and Go" <sup>(1)</sup>	Arbitrary
<b>(1)</b> The energy saving function "Stop and Go" is activated by default.	

**NOTE:** The device fans are automatically controlled depending on the start/stop request.

If the power stage is disabled unintentionally, for example as a result of power outage, errors or functions, there is a possibility that the motor is no longer decelerated in a controlled way.

<p><b>⚠ WARNING</b></p> <p><b>UNANTICIPATED EQUIPMENT OPERATION</b></p> <p>Verify that movements without braking effect does not result in unsafe conditions.</p> <p><b>Failure to follow these instructions can result in death, serious injury, or equipment damage.</b></p>
--

# Preliminary Instructions

## What's in This Chapter

Responsibility .....	41
Installation Site.....	41
Increased Motor Speed.....	41
Overvoltage Protective Circuit .....	42
Residual Current Circuit Breaker .....	42
Automatic Restarting .....	43
Locking of the Frequency Inverter .....	43
Stop and Go Function .....	44
Connecting and Disconnecting the Motor .....	44
Multi-motor Operation .....	44
Operation of ATEX Motors .....	45

## Responsibility

All stated connection recommendations and planning remarks are to be taken merely as suggestions which must be adapted to the local conditions and regulations concerning installation and usage.

This applies especially to the functional safety regulations for machines, the EMC regulations and the general regulations for human protection.

## Installation Site

The drives are qualified for vertical installation in electrical operating rooms as well as in the area of production facilities.

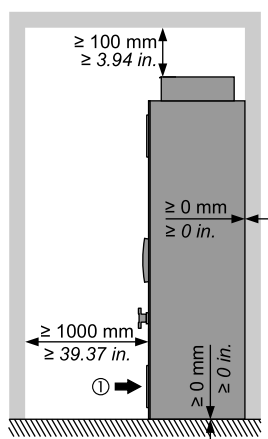

- Observe the specified minimum distances. Mounting the Drive Systems side by side or back to back is allowed.
  - Install the drive vertically on a non-combustible, solid and vibration-free ground.
  - Take care of compliance with the ambient conditions.
  - Take care that the air exchange is sufficient for dissipation of the lost heat during operation.
- ① Air inflow temperature: -10...+50 °C (14...122 °F) (below 0 °C (32 °F) with additional enclosure heating, above +40 °C (104 °F) with derating)

**NOTE:** At enclosure design IP54 the ATV980 frequency inverter is qualified for pollution degree 3 according to EN 61800-5-1.

**NOTE:** Further information is given in the installation manual.

This equipment has been designed to operate outside of any hazardous location. Only install this equipment in zones known to be free of a hazardous atmosphere.

<b>⚠ DANGER</b>
<b>POTENTIAL FOR EXPLOSION</b> Install and use this equipment in non-hazardous locations only. <b>Failure to follow these instructions will result in death or serious injury.</b>

## Increased Motor Speed

With the Altivar Process Drive Systems it is possible to control the rotational speed of motors from 0.1...599 Hz.

## Overvoltage Protective Circuit

The AC and DC control circuits must be protected against overvoltage. Use flyback diodes for DC control circuits.

For AC control circuits, RC circuits are advisable because they can reduce the peak overvoltage and the rise time while varistors only reduce the peak voltage.

### **NOTICE**

#### **INOPERATIVE CONTROL CIRCUITS**

Verify that all inductances such as relays, contactors, external brakes, etc. are equipped with appropriate overvoltage protection circuits.

**Failure to follow these instructions can result in equipment damage.**

## Residual Current Circuit Breaker

Frequency inverters, especially those with additional EMC filters and shielded motor cables, lead an increased leakage current against ground.

The leakage current depends on:

- The length of the motor cable
- The type of laying and whether the motor cable is shielded or not
- The set pulse frequency
- The use of an additional radio frequency interference filter
- The grounding of the motor at its installation place (grounded or non-grounded)

Depending on the conditions, the leakage current of plants with high cable lengths can be absolutely higher than 100 mA !

The built-in residual current detection has no current-limiting effect. It only helps to protect the drive and is no human protection.

Particularly because of the capacitors of the radio frequency interference filter, an unintentional triggering of a residual current circuit breaker may occur at the moment of switching on. As well, the ground capacitances may cause an incorrect triggering during operation. On the other hand, it is possible that the triggering is blocked by means of DC components which are caused by the mains rectification at the input of the inverter.

Direct current can be introduced in the protective ground conductor of this device. If a residual current device (RCD / GFCI) or a residual current monitor (RCM) is used for additional protection against direct or indirect contact, the following specific types must be used:

## ⚠ WARNING

### DIRECT CURRENT CAN BE INTRODUCED INTO THE PROTECTIVE GROUND CONDUCTOR

Use a Type B Residual Current Device (RCD / GFCI) or a Residual Current Monitor (RCM) that has approval for use with frequency inverters and is sensitive to all types of current.

**Failure to follow these instructions can result in death, serious injury, or equipment damage.**

Further conditions for use of a residual current device:

- The device has an increased leakage current at the moment power is applied. Use a residual current device (RCD / GFCI) or a residual current monitor (RCM) with a response delay.
- High-frequency currents must be filtered.

**NOTE:** Protect the other loads by means of a separate residual current circuit breaker.

## Automatic Restarting

This function increases the availability, especially for drives that are not integrated into the plant control via a fieldbus system. Depending on the parameterization, the frequency inverter can automatically start-up again after each mains switch-on or mains recurrence.

## Locking of the Frequency Inverter

Altivar Process Drive Systems include the standard protective function "Safe Torque Off (STO)", which helps to prevent any unintended start-up of the motor. This function fulfills, when correctly wired, the machine standard ISO 13849-1 Performance level PL e, the IEC/EN 61508 Safety integrity level SIL 3 standard for functional safety and the power drive system standard IEC/EN 61800-5-2.

**NOTE:** You will find further information in the Safety Function Manual (NHA80947).

The safety function STO (Safe Torque Off) does not remove power from the DC bus. The safety function STO only removes power to the motor. The DC bus voltage and the mains voltage to the drive are still present.

## ⚠⚠ DANGER

### HAZARD OF ELECTRIC SHOCK

- Do not use the safety function STO for any other purposes than its intended function.
- Use an appropriate switch, that is not part of the circuit of the safety function STO, to disconnect the product from the mains power.

**Failure to follow these instructions will result in death or serious injury.**

When the safety function STO is triggered, the power stage is immediately disabled. In the case of vertical applications or external forces acting on the motor shaft, you may have to take additional measures to bring the motor to a standstill and to keep it at a standstill when the safety function STO is used, for example, by using a service brake.

## ⚠ WARNING

### INSUFFICIENT DECELERATION OR UNINTENDED EQUIPMENT OPERATION

- Verify that using the safety function STO does not result in unsafe conditions.
- If standstill is required in your application, ensure that the motor comes to a secure standstill when the safety function STO is used.

**Failure to follow these instructions can result in death, serious injury, or equipment damage.**

## Stop and Go Function



All Altivar Process Drive Systems include the energy saving function "Stop and Go". When the frequency inverter gets a stop or lock request, the own consumption is clearly decreased by reducing the DC link voltage. With the next start request the DC link is charged and the motor can start-up again.

**NOTE:** For applications where a start delay of 1...2 s is undesired, this energy saving function can be also deactivated.

## Connecting and Disconnecting the Motor

Alternatively to the use of the control terminal STO "Safe Torque Off" a safety switch or a motor contactor can be installed to connect and disconnect the motor – Design on request.

After connection the motor restarts by means of the function "Catch on the fly".

## Multi-motor Operation

With Altivar Process Drive Systems it is possible to operate several motors at one output.

For multi-motor applications (e.g. roller conveyors), however, observe the following:

- The sum of the nominal currents has to be less than the nominal current of the inverter.
- A different speed control is not possible.
- The total motor cable length has to be taken into consideration.
- No high starting torque is available.
- The inverter does not provide individual motor overload protection.
- Autotuning is not possible (but also not necessary).
- Activation of individual motors is only permitted when the starting current remains less than the maximum inverter current.

## Operation of ATEX Motors

If you want to operate an explosion-protected motor (ATEX) with this drive system, you must use the option "Motor monitoring PTC with ATEX certificate".

**NOTE:** You will find further information about the operation of ATEX motors in the ATEX manual (NVE42416).

This equipment has been designed to operate outside of any hazardous location. Only install this equipment in zones known to be free of a hazardous atmosphere.

### **DANGER**

#### **POTENTIAL FOR EXPLOSION**

Install and use this equipment in non-hazardous locations only.

**Failure to follow these instructions will result in death or serious injury.**

# ATV980●●●●4X1

## What's in This Part

ATV980 Regenerative Drive Systems for 400 V Mains .....	47
General Technical Data .....	48
Protection Degree .....	50
Cooling concept .....	51
Maximum Ambient Temperature .....	52
Continuous Current and Overload at < 2 Hz .....	53
Specification .....	54
Circuit Diagram .....	83
Mains Connection .....	84
Motor Connection .....	88
Predefined Customizations .....	96

# ATV980 Regenerative Drive Systems for 400 V Mains

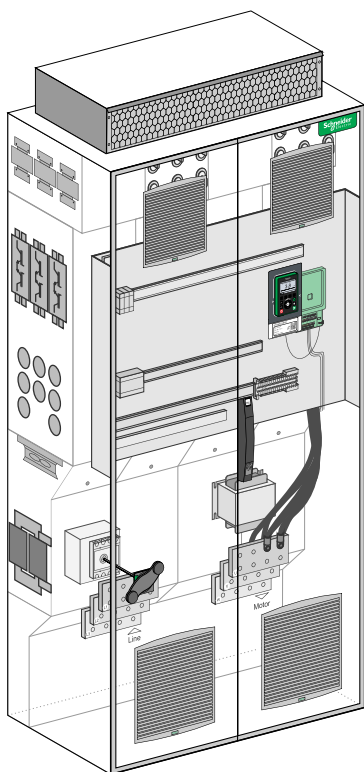

**Power components:**

- Mains connection terminals
- Main switch
- Semiconductor fuses
- Clean power filter with EMC filter
- Active Front End module(s)
- Inverter module(s)
- dv/dt filter choke(s) (optional at size 1a)
- Terminals for motor connection

**Design:**

- Floor-standing enclosure
- Integrated control panel
- Protection degree IP23
- Forced cooling
- -10...+50 °C (below 0 °C with additional enclosure heating, above +40 °C with derating)
- Graphical operating panel in the enclosure door

**Scope of delivery:**

- ATV980 Regenerative Drive System
- Multilingual instructions
- Enclosure layout plans consisting of circuit diagram, terminal connection table, list of materials and design drawing
- Transport packaging

## Sophisticated service concept with QR code



- Modular design allows easy logistics of spare parts.
- Optimized costs for maintenance due to the dynamic maintenance schedule with integrated monitoring of the individual components.
- Simple exchange of power modules and fans.
- Quick assistance with dynamic QR codes and Customer Care App.

**Documentation** →  **Asset Life Cycle Documents:** Access to the **Asset Lifecycle Manager** for all product-specific documentation.

## General Technical Data

Input	
Rated voltage $U_n$	for TT, TN-C or TN-S: <ul style="list-style-type: none"> <li>• 3 AC 380 V -10 % ... 415 V +6 %</li> <li>• 3 AC 400 V -10 % ... 415 V +10 %</li> <li>• 3 AC 440 V <math>\pm 10</math> %</li> <li>• 3 AC 480 V <math>\pm 10</math> %</li> </ul> Other voltages and mains topologies on request
Rated frequency $f_n$	50 / 60 Hz $\pm 5$ %
Total harmonic distortion	$\leq 5$ % (at nominal load and sinusoidal mains voltage)
Power factor $\cos \Phi$	$> 0.99$ (at 30...120 % load)
Oversvoltage category	Category III according to EN 50178

Output	
Control method	Asynchronous motor: Constant load torque (open/closed loop), variable load torque (open/closed loop), energy saving Synchronous motor: PM (permanent magnet) motor (open/closed loop)
Voltage	3 AC 0...100 % mains voltage
Overload	Normal Duty (ND): 120 % for 60 s per 10 minutes Heavy Duty (HD): 150 % for 60 s per 10 minutes
Pulse frequency	2.5 kHz, adjustable from 2...8 kHz
Frequency	0.1...599 Hz
Short-circuit protection	Short-circuits and ground faults are handled by overcurrent function and switch-off the output.
Speed accuracy	V/f mode: slip frequency VC without feedback: 0.3 x slip frequency

Mechanical strenght	
Mechanical vibrations	According to IEC/EN 60068-2-6 1.5 mm at 3...10 Hz, 0.6 g at 10...200 Hz (3M3 according to IEC/EN 60721-3-3)
Mechanical shock	According to IEC/EN 60068-2-27 4 g for 11 ms (3M2 according to IEC/EN 60721-3-3)

<b>Ambient conditions</b>	
Ambient temperature	-10...+50 °C (below 0 °C with additional enclosure heating, above +40 °C with derating)  3K3 according to IEC/EN 60721-3-3
Storage / Transport temperature	-25...+70 °C
Protection degree	Door closed: IP23 (optionally enclosure design IP54) Door open: IP2x
Environmental class / Humidity	Class 3K3 in accordance with IEC/EN 60721-3-3 / no condensation inside the enclosure, max. 95 % relative humidity
Altitude	Up to 1000 m no derating necessary 1000...2000 m derating of 1 % / 100 m (for all types of mains) 2000...3800 m derating of 1 % / 100 m (only TT/TN, IT) 3800...4800 m derating of 1 % / 100 m (only TT/TN)
Allowed pollution	Pollution degree IP23: 2 according to EN 61800-5-1 Pollution degree IP54 (optional): 3 according to EN 61800-5-1  Chemical / mechanical classification: 3C3 and 3S3 according to EN 60721-3-3
Protection class	Class 1 according to EN 61800-5-1

<b>Functional safety</b>	
Functional safety of the drive	The function "Safe Torque Off" (STO) allows a controlled shut-down and switch-off of the power supply to the motor. It also helps to prevent any unintended start of the motor according to ISO 13849-1, performance level PL e, according to IEC/EN 61508 safety integrity level SIL 3 and IEC/EN 61800-5-2.
Response time	≤ 100 ms at STO (Safe Torque Off)

<b>Standards</b>	
Basic standard	The devices are designed, built and tested on the basis of EN 61800-2, EN 61800-3, EN 61800-5-1 and EN 60204-1.
EMC immunity	According to EN 61800-3, second environment (EN 61000-4-2; EN 61000-4-3; EN 61000-4-4; EN 61000-4-5; EN 61000-4-6)
EMC emission	In accordance with product standard EN 61800-3, second environment, category C3
Insulation	Galvanic insulation of the control circuit in accordance with EN 61800-5-1 PELV (Protective Extra Low Voltage)
Standards	CE, EAC, RCM, ATEX, IEEE 519 (THDi < 5%), RFI filter for second "industrial environment" C3 integrated

# Protection Degree

The standard design of the Altivar Process Drive Systems complies with protection degree IP23. It provides optimal cooling of the built-in frequency inverter modules and all power components as well as maximum compactness at the same time.

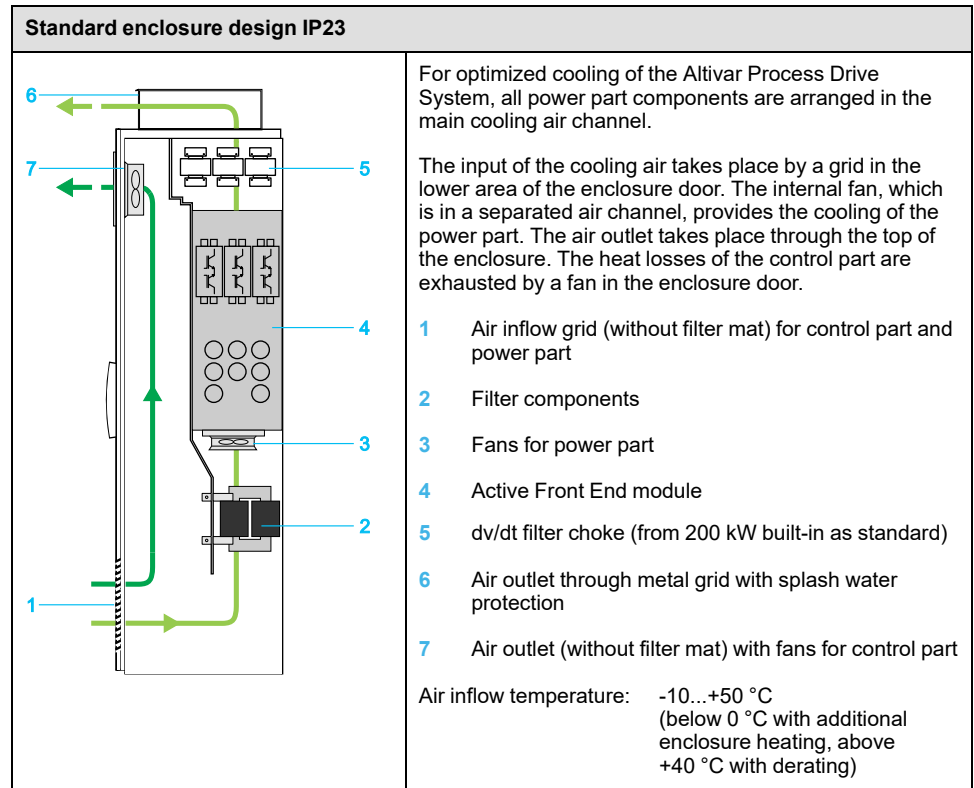

**NOTE:** For details about the increased protection degree IP54 see chapter Increased Protection Degree IP54, page 128.

# Cooling concept

## Control/monitoring of fans

The power part fans as well as the fans in the enclosure door are controlled energy optimized depending on the operation. Switching the fans on and off is derived from the start/stop request.

The fans in the power part are equipped with speed monitoring and the fans in the enclosure doors include a temperature monitoring and that helps to protect the Altivar Process Drive Systems. If one of these monitoring units triggers, a warning message is generated.

Furthermore, the operating hours of all fans can be monitored and a warning message can be triggered when the set limit is exceeded.

## Overtemperature protection

The temperature of the power part is monitored all the time. In case of overtemperature the pulse frequency or the power is automatically reduced. The temperature of the control part is monitored with a thermostat. When the set temperature is exceeded, a warning message is generated. Only in case of insufficient cooling the drive is necessarily shut down.

# Maximum Ambient Temperature

Depending on the chosen pulse frequency, the maximum ambient temperature and the desired output frequency a derating is necessary. This can be determined by means of the following diagrams.

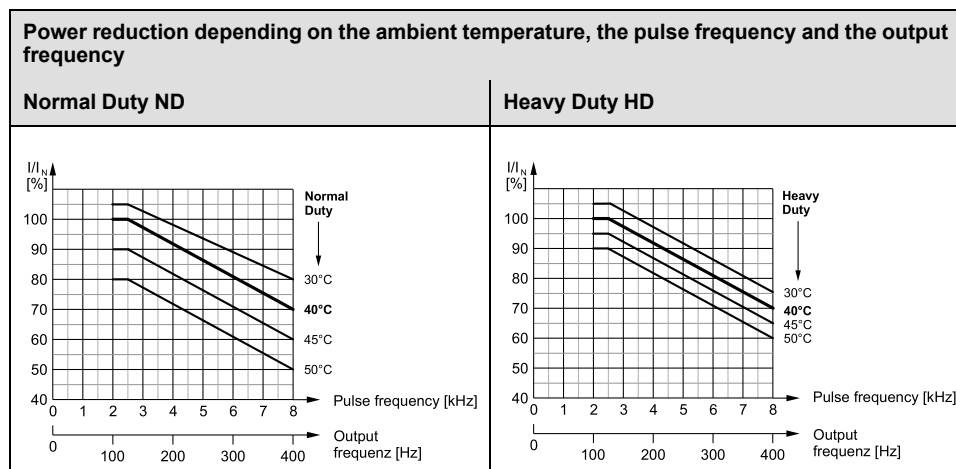

Observe the following guidelines:

- In case of output frequencies higher than 125 Hz the pulse frequency is increased automatically. So the pulse frequency is increased to 4 kHz at 200 Hz output frequency, for example. Consequently, a derating of 8 % at max. 40°C has to be considered.
- Due to the reduction of the output current also the overload capability of the Altivar Process Drive System is reduced.
- At higher pulse frequencies the allowed motor cable length is reduced (see Length of Motor Cables, page 91).
- For full shaft power the motor size should not be more than one power rating bigger than the drive.

**NOTE:** If the ambient temperature is too high, the pulse frequency is automatically reduced which helps to prevent an overload of the inverter (except in case of operation with sinus-motor-filter).

## Continuous Current and Overload at < 2 Hz

In order to avoid thermal overload of the power semiconductors (IGBTs), the pulse frequency will be reduced automatically near 0 Hz operation. If the overload takes too long the drive will change to trip condition.

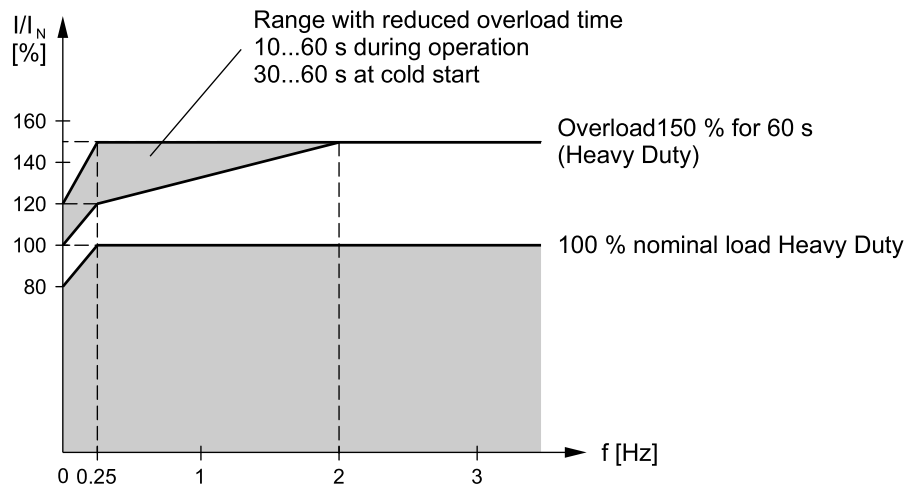

**NOTE:** If the frequency inverter is operated with output frequencies < 2 Hz the overload time at high overload up to 150 % is lower than 60 s. This restriction needs to be observed only for drives which continuously operate around 0 Hz and require overloads up to 150 %.

There are practically no effects on the start of a drive because even big motors have a nominal slip greater than 0.25 Hz.

# Specification

## What's in This Chapter

Technical Data ATV980C11●4X1 .....	55
Dimensions IP23 for Size 1a .....	56
Interior View IP23 for Size 1a .....	56
Technical Data ATV980C13●4X1 .....	57
Dimensions IP23 for Size 1a .....	58
Interior View IP23 for Size 1a .....	58
Technical Data ATV980C16●4X1 .....	59
Dimensions IP23 for Size 1a .....	60
Interior View IP23 for Size 1a .....	60
Technical Data ATV980C20●4X1 .....	61
Dimensions IP23 for Size 2a .....	62
Interior View IP23 for Size 2a .....	62
Technical Data ATV980C25●4X1 .....	63
Dimensions IP23 for Size 2a .....	64
Interior View IP23 for Size 2a .....	64
Technical Data ATV980C31●4X1 .....	65
Dimensions IP23 for Size 2a .....	66
Interior View IP23 for Size 2a .....	66
Technical Data ATV980C35●4X1 .....	67
Dimensions IP23 for Size 3a .....	68
Interior View IP23 for Size 3a .....	68
Technical Data ATV980C40●4X1 .....	69
Dimensions IP23 for Size 3a .....	70
Interior View IP23 for Size 3a .....	70
Technical Data ATV980C45●4X1 .....	71
Dimensions IP23 for Size 3a .....	72
Interior View IP23 for Size 3a .....	72
Technical Data ATV980C50●4X1 .....	73
Dimensions IP23 for Size 3a .....	74
Interior View IP23 for Size 3a .....	74
Technical Data ATV980C56●4X1 .....	75
Dimensions IP23 for Size 4a .....	76
Interior View IP23 for Size 4a .....	76
Technical Data ATV980C63●4X1 .....	77
Dimensions IP23 for Size 4a .....	78
Interior View IP23 for Size 4a .....	78
Technical Data ATV980C71●4X1 .....	79
Dimensions IP23 for Size 5a .....	80
Interior View IP23 for Size 5a .....	80
Technical Data ATV980C80●4X1 .....	81
Dimensions IP23 for Size 5a .....	82
Interior View IP23 for Size 5a .....	82

# Technical Data ATV980C11•4X1

Type		ATV980C11•4X1	
Nominal data		Normal Duty ND	Heavy Duty HD <sup>(1)</sup>
Typical motor rating $P_n$	$U_n = 400\text{ V}$	110 kW	90 kW
	$U_n = 440\text{ V}$	110 kW	90 kW
	$U_n = 480\text{ V}$	132 kW	110 kW
Rated output current $I_n$		211 A	173 A
Maximum current $I_{MAX}$ for 60 s per 10 minutes		253 A	260 A
<b>Input</b>			
Rated input current $I_{in}$ (at $I_{sc} = 22\text{ kA}$ )	$U_n = 400\text{ V}$	175 A	144 A
	$U_n = 440\text{ V}$	159 A	132 A
	$U_n = 480\text{ V}$	175 A	147 A
Rated apparent power $S_n$	$U_n = 400\text{ V}$	121 kVA	100 kVA
	$U_n = 440\text{ V}$	121 kVA	100 kVA
	$U_n = 480\text{ V}$	145 kVA	123 kVA
Current harmonic THDi <sup>(2)</sup>		< 5 %	
<b>Protection for upstream cables</b>			
Pre-fuse	$U_n = 400, 440, 480\text{ V}$	250 A gG	250 A gG
Circuit breaker $I_{therm} / I_{magn}$		230 A / 2 kA	200 A / 2 kA
<b>Internal short-circuit protection</b>			
Fuse	$U_n = 400, 440, 480\text{ V}$	250 A aR	
<b>Characteristics</b>			
Efficiency at $I_n$		0.965	
Heat losses at $I_n$	Total losses	4220 W	3480 W
	Control part only	560 W	470 W
Weight	Net	400 kg	
	Gross	445 kg	
<b>Ambient conditions</b>			
Air flow	Power part	1160 m <sup>3</sup> /h	
	Control part	140 m <sup>3</sup> /h	
Sound pressure level		70 dB(A)	
Rated short-circuit current $I_{sc}$	Minimum <sup>(3)</sup>	3 kA	
	Maximum <sup>(4)</sup>	50 kA (100 ms)	
<b>Mains and motor connection <sup>(5)</sup></b>			
Typical cable		1x (3x 120 mm <sup>2</sup> ) or 2x (3x 50 mm <sup>2</sup> )	1x (3x 95 mm <sup>2</sup> )
Max. Cable cross section <sup>(6)</sup>	Cable	2x (3x 240 mm <sup>2</sup> ) or 3x (3x 120 mm <sup>2</sup> ) or 4x (3x 95 mm <sup>2</sup> )	
	Cable entry <sup>(7)</sup>	max. 360 mm	
Terminals per phase		4x M12	
<p><b>(1)</b> For Heavy Duty HD operation parameter [Dual Rating] <i>drt</i> has to be set to [High rating] <i>HiGH</i> (see programming manual NHA80757).</p> <p><b>(2)</b> For details see table under chapter Mains Current Harmonics / Mains Voltage Distortion, page 87.</p> <p><b>(3)</b> Minimum mains short-circuit current</p> <p><b>(4)</b> Permitted short-circuit current when the specified pre-fuse or circuit breaker is installed</p> <p><b>(5)</b> You will find further information at chapter Mains Connection, page 84 and at chapter Motor Connection, page 88.</p> <p><b>(6)</b> Greater connection cross sections are possible with the separate connection enclosure.</p> <p><b>(7)</b> Maximum possible width of cables connected next to each other in the enclosure</p>			

## Dimensions IP23 for Size 1a

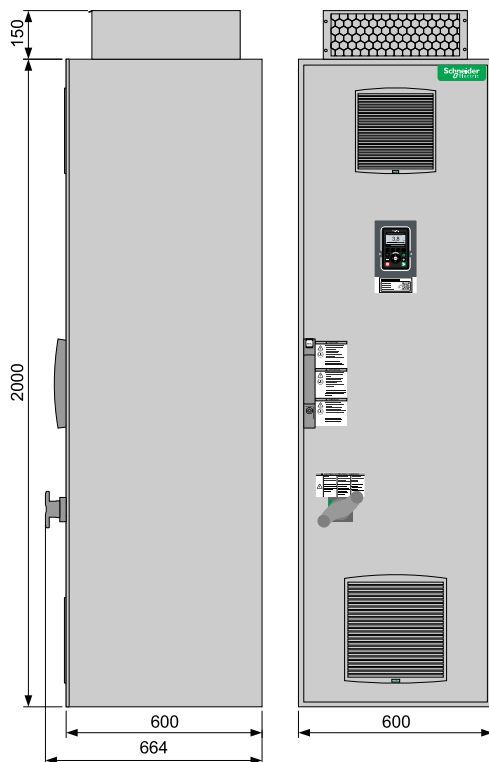

## Interior View IP23 for Size 1a

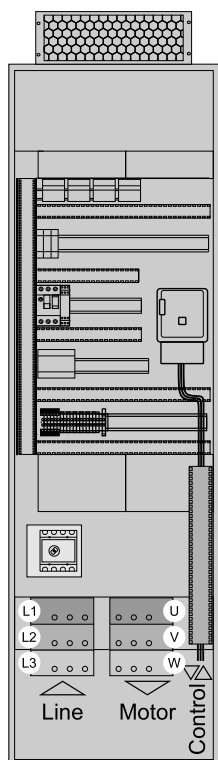

**NOTE:** Following customizations affect the total dimensions:

- Increased protection degree IP54
- Enclosure plinth for basic device
- Connection enclosure cable from top/ bottom
- Braking option BUO

# Technical Data ATV980C13•4X1

Type		ATV980C13•4X1	
Nominal data		Normal Duty ND	Heavy Duty HD <sup>(1)</sup>
Typical motor rating $P_n$	$U_n = 400\text{ V}$	132 kW	110 kW
	$U_n = 440\text{ V}$	132 kW	110 kW
	$U_n = 480\text{ V}$	160 kW	132 kW
Rated output current $I_n$		250 A	211 A
Maximum current $I_{MAX}$ for 60 s per 10 minutes		300 A	317 A
<b>Input</b>			
Rated input current $I_{in}$ (at $I_{sc} = 35\text{ kA}$ )	$U_n = 400\text{ V}$	208 A	174 A
	$U_n = 440\text{ V}$	190 A	159 A
	$U_n = 480\text{ V}$	211 A	175 A
Rated apparent power $S_n$	$U_n = 400\text{ V}$	144 kVA	121 kVA
	$U_n = 440\text{ V}$	145 kVA	121 kVA
	$U_n = 480\text{ V}$	175 kVA	145 kVA
Current harmonic THDi <sup>(2)</sup>		< 5 %	
<b>Protection for upstream cables</b>			
Pre-fuse	$U_n = 400, 440, 480\text{ V}$	300 A gG	300 A gG
Circuit breaker $I_{therm} / I_{magn}$		280 A / 3 kA	240 A / 3 kA
<b>Internal short-circuit protection</b>			
Fuse	$U_n = 400, 440, 480\text{ V}$	315 A aR	
<b>Characteristics</b>			
Efficiency at $I_n$		0.965	
Heat losses at $I_n$	Total losses	5110 W	4200 W
	Control part only	660 W	540 W
Weight	Net	400 kg	
	Gross	445 kg	
<b>Ambient conditions</b>			
Air flow	Power part	1160 m <sup>3</sup> /h	
	Control part	140 m <sup>3</sup> /h	
Sound pressure level		70 dB(A)	
Rated short-circuit current $I_{sc}$	Minimum <sup>(3)</sup>	3.5 kA	
	Maximum <sup>(4)</sup>	50 kA (100 ms)	
<b>Mains and motor connection <sup>(5)</sup></b>			
Typical cable		1x (3x 150 mm <sup>2</sup> ) or 2x (3x 70 mm <sup>2</sup> )	1x (3x 120 mm <sup>2</sup> ) or 2x (3x 50 mm <sup>2</sup> )
Max. Cable cross section <sup>(6)</sup>	Cable	2x (3x 240 mm <sup>2</sup> ) or 3x (3x 120 mm <sup>2</sup> ) or 4x (3x 95 mm <sup>2</sup> )	
	Cable entry <sup>(7)</sup>	max. 360 mm	
Terminals per phase		4x M12	
<p><b>(1)</b> For Heavy Duty HD operation parameter [Dual Rating] <i>drt</i> has to be set to [High rating] <i>HiGH</i> (see programming manual NHA80757).</p> <p><b>(2)</b> For details see table under chapter Mains Current Harmonics / Mains Voltage Distortion, page 87.</p> <p><b>(3)</b> Minimum mains short-circuit current</p> <p><b>(4)</b> Permitted short-circuit current when the specified pre-fuse or circuit breaker is installed</p> <p><b>(5)</b> You will find further information at chapter Mains Connection, page 84 and at chapter Motor Connection, page 88.</p> <p><b>(6)</b> Greater connection cross sections are possible with the separate connection enclosure.</p> <p><b>(7)</b> Maximum possible width of cables connected next to each other in the enclosure</p>			

## Dimensions IP23 for Size 1a

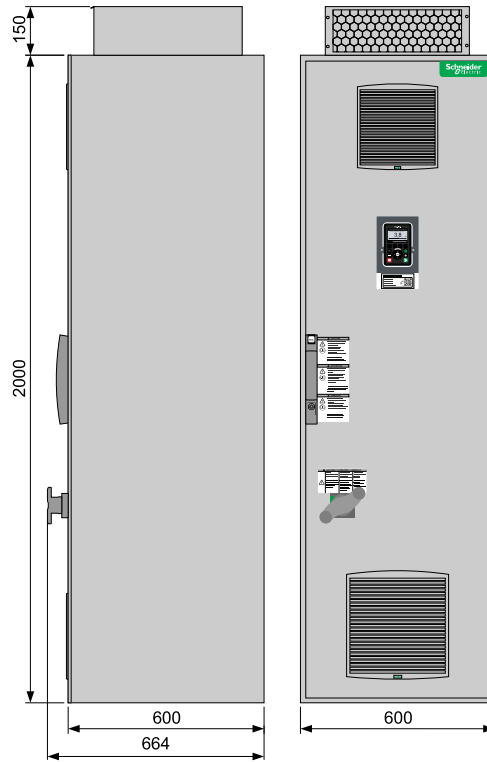

## Interior View IP23 for Size 1a

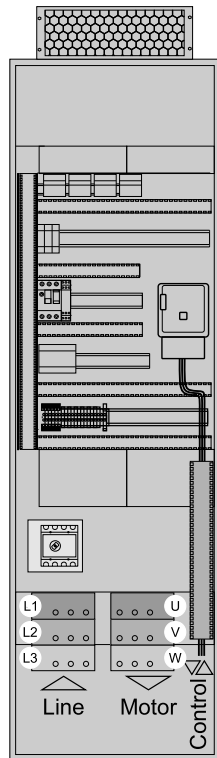

**NOTE:** Following customizations affect the total dimensions:

- Increased protection degree IP54
- Enclosure plinth for basic device
- Connection enclosure cable from top/ bottom
- Braking option BUO

# Technical Data ATV980C16•4X1

Type		ATV980C16•4X1	
Nominal data		Normal Duty ND	Heavy Duty HD <sup>(1)</sup>
Typical motor rating P <sub>n</sub>	U <sub>n</sub> = 400 V	160 kW	132 kW
	U <sub>n</sub> = 440 V	160 kW	132 kW
	U <sub>n</sub> = 480 V	180 kW	160 kW
Rated output current I <sub>n</sub>		302 A	250 A
Maximum current I <sub>MAX</sub> for 60 s per 10 minutes		362 A	375 A
<b>Input</b>			
Rated input current I <sub>in</sub> (at I <sub>scc</sub> = 35 kA)	U <sub>n</sub> = 400 V	252 A	208 A
	U <sub>n</sub> = 440 V	229 A	190 A
	U <sub>n</sub> = 480 V	236 A	211 A
Rated apparent power S <sub>n</sub>	U <sub>n</sub> = 400 V	174 kVA	144 kVA
	U <sub>n</sub> = 440 V	174 kVA	145 kVA
	U <sub>n</sub> = 480 V	196 kVA	175 kVA
Current harmonic THDi <sup>(2)</sup>		< 5 %	
<b>Protection for upstream cables</b>			
Pre-fuse	U <sub>n</sub> = 400, 440, 480 V	315 A gG	300 A gG
Circuit breaker I <sub>therm</sub> / I <sub>magn</sub>		315 A / 3 kA	280 A / 3 kA
<b>Internal short-circuit protection</b>			
Fuse	U <sub>n</sub> = 400, 440, 480 V	400 A aR	
<b>Characteristics</b>			
Efficiency at I <sub>n</sub>		0.965	
Heat losses at I <sub>n</sub>	Total losses	6400 W	5100 W
	Control part only	820 W	650 W
Weight	Net	400 kg	
	Gross	445 kg	
<b>Ambient conditions</b>			
Air flow	Power part	1160 m <sup>3</sup> /h	
	Control part	140 m <sup>3</sup> /h	
Sound pressure level		70 dB(A)	
Rated short-circuit current I <sub>scc</sub>	Minimum <sup>(3)</sup>	4 kA	
	Maximum <sup>(4)</sup>	50 kA (100 ms)	
<b>Mains and motor connection <sup>(5)</sup></b>			
Typical cable		1x (3x 185 mm <sup>2</sup> ) or 2x (3x 95 mm <sup>2</sup> )	1x (3x 150 mm <sup>2</sup> ) or 2x (3x 70 mm <sup>2</sup> )
Max. Cable cross section <sup>(6)</sup>	Cable	2x (3x 240 mm <sup>2</sup> ) or 3x (3x 120 mm <sup>2</sup> ) or 4x (3x 95 mm <sup>2</sup> )	
	Cable entry <sup>(7)</sup>	max. 360 mm	
Terminals per phase		4x M12	
<p><b>(1)</b> For Heavy Duty HD operation parameter [Dual Rating] <i>drt</i> has to be set to [High rating] <i>HiGH</i> (see programming manual NHA80757).</p> <p><b>(2)</b> For details see table under chapter Mains Current Harmonics / Mains Voltage Distortion, page 87.</p> <p><b>(3)</b> Minimum mains short-circuit current</p> <p><b>(4)</b> Permitted short-circuit current when the specified pre-fuse or circuit breaker is installed</p> <p><b>(5)</b> You will find further information at chapter Mains Connection, page 84 and at chapter Motor Connection, page 88.</p> <p><b>(6)</b> Greater connection cross sections are possible with the separate connection enclosure.</p> <p><b>(7)</b> Maximum possible width of cables connected next to each other in the enclosure</p>			

## Dimensions IP23 for Size 1a

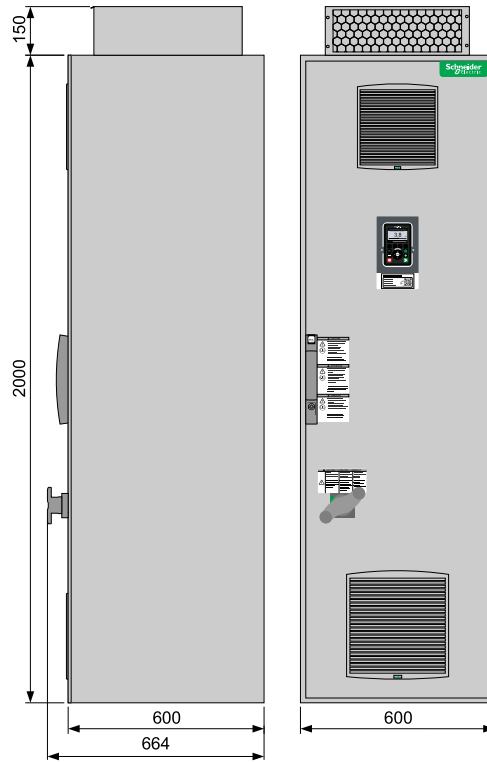

## Interior View IP23 for Size 1a

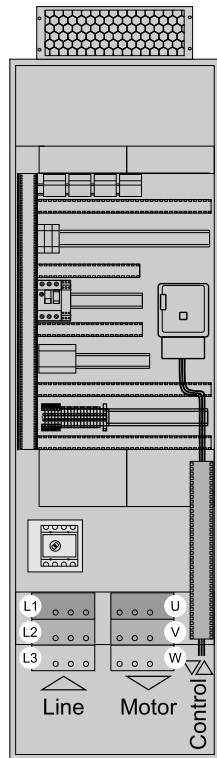

**NOTE:** Following customizations affect the total dimensions:

- Increased protection degree IP54
- Enclosure plinth for basic device
- Connection enclosure cable from top/ bottom
- Braking option BUO

# Technical Data ATV980C20•4X1

Type		ATV980C20•4X1	
Nominal data		Normal Duty ND	Heavy Duty HD <sup>(1)</sup>
Typical motor rating $P_n$	$U_n = 400\text{ V}$	200 kW	160 kW
	$U_n = 440\text{ V}$	200 kW	160 kW
	$U_n = 480\text{ V}$	220 kW	180 kW
Rated output current $I_n$		370 A	302 A
Maximum current $I_{MAX}$ for 60 s per 10 minutes		444 A	453 A
<b>Input</b>			
Rated input current $I_{in}$ (at $I_{sc} = 35\text{ kA}$ )	$U_n = 400\text{ V}$	313 A	252 A
	$U_n = 440\text{ V}$	285 A	229 A
	$U_n = 480\text{ V}$	287 A	236 A
Rated apparent power $S_n$	$U_n = 400\text{ V}$	217 kVA	174 kVA
	$U_n = 440\text{ V}$	217 kVA	174 kVA
	$U_n = 480\text{ V}$	239 kVA	196 kVA
Current harmonic THDi <sup>(2)</sup>		< 5 %	
<b>Protection for upstream cables</b>			
Pre-fuse	$U_n = 400, 440, 480\text{ V}$	400 A gG	355 A gG
Circuit breaker $I_{therm} / I_{magn}$		400 A / 4 kA	330 A / 4 kA
<b>Internal short-circuit protection</b>			
Fuse	$U_n = 400, 440, 480\text{ V}$	2x 250 A aR	
<b>Characteristics</b>			
Efficiency at $I_n$		0.965	
Heat losses at $I_n$	Total losses	7890 W	6450 W
	Control part only	940 W	770 W
Weight	Net	700 kg	
	Gross	755 kg	
<b>Ambient conditions</b>			
Air flow	Power part	2320 m <sup>3</sup> /h	
	Control part	280 m <sup>3</sup> /h	
Sound pressure level		73 dB(A)	
Rated short-circuit current $I_{sc}$	Minimum <sup>(3)</sup>	5.5 kA	
	Maximum <sup>(4)</sup>	50 kA (100 ms)	
<b>Mains and motor connection <sup>(5)</sup></b>			
Typical cable		2x (3x 120 mm <sup>2</sup> ) or 3x (3x 70 mm <sup>2</sup> )	1x (3x 185 mm <sup>2</sup> ) or 2x (3x 95 mm <sup>2</sup> )
Max. Cable cross section <sup>(6)</sup>	Cable	2x (3x 240 mm <sup>2</sup> ) or 4x (3x 185 mm <sup>2</sup> )	
	Cable entry <sup>(7)</sup>	max. 760 mm	
Terminals per phase		4x M12	
<p><b>(1)</b> For Heavy Duty HD operation parameter [Dual Rating] <i>drt</i> has to be set to [High rating] <i>HiGH</i> (see programming manual NHA80757).</p> <p><b>(2)</b> For details see table under chapter Mains Current Harmonics / Mains Voltage Distortion, page 87.</p> <p><b>(3)</b> Minimum mains short-circuit current</p> <p><b>(4)</b> Permitted short-circuit current when the specified pre-fuse or circuit breaker is installed</p> <p><b>(5)</b> You will find further information at chapter Mains Connection, page 84 and at chapter Motor Connection, page 88.</p> <p><b>(6)</b> Greater connection cross sections are possible with the separate connection enclosure.</p> <p><b>(7)</b> Maximum possible width of cables connected next to each other in the enclosure</p>			

## Dimensions IP23 for Size 2a

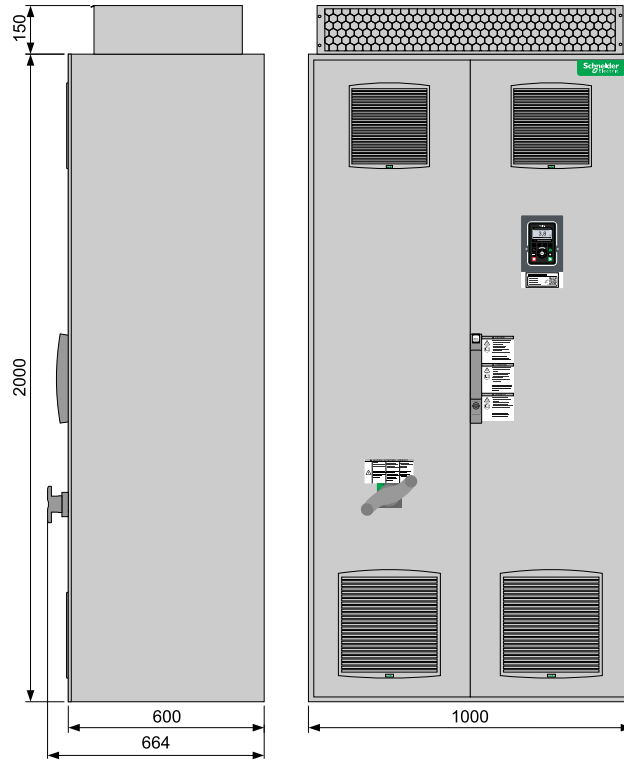

## Interior View IP23 for Size 2a

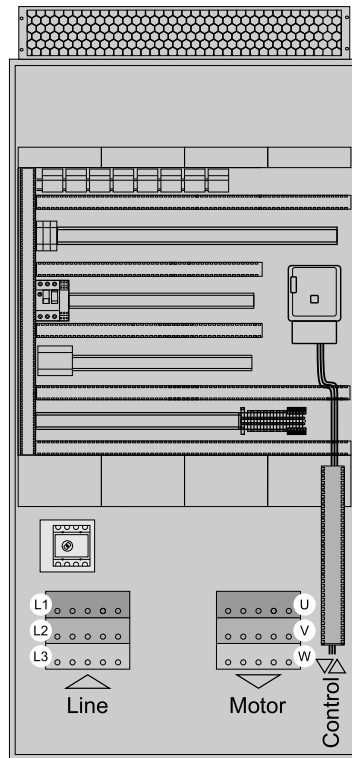

**NOTE:** Following customizations affect the total dimensions:

- Increased protection degree IP54
- Enclosure plinth for basic device
- Connection enclosure cable from top/ bottom
- Braking option BUO

# Technical Data ATV980C25•4X1

Type	ATV980C25•4X1		
Nominal data		Normal Duty ND	Heavy Duty HD <sup>(1)</sup>
Typical motor rating $P_n$	$U_n = 400\text{ V}$	250 kW	200 kW
	$U_n = 440\text{ V}$	250 kW	200 kW
	$U_n = 480\text{ V}$	280 kW	220 kW
Rated output current $I_n$		477 A	370 A
Maximum current $I_{MAX}$	for 60 s per 10 minutes	572 A	555 A
<b>Input</b>			
Rated input current $I_{in}$ (at $I_{sc} = 50\text{ kA}$ )	$U_n = 400\text{ V}$	389 A	313 A
	$U_n = 440\text{ V}$	354 A	285 A
	$U_n = 480\text{ V}$	363 A	287 A
Rated apparent power $S_n$	$U_n = 400\text{ V}$	270 kVA	217 kVA
	$U_n = 440\text{ V}$	270 kVA	217 kVA
	$U_n = 480\text{ V}$	302 kVA	239 kVA
Current harmonic THDi <sup>(2)</sup>		< 5 %	
<b>Protection for upstream cables</b>			
Pre-fuse	$U_n = 400, 440, 480\text{ V}$	500 A gG	400 A gG
Circuit breaker $I_{therm} / I_{magn}$		500 A / 5 kA	400 A / 5 kA
<b>Internal short-circuit protection</b>			
Fuse	$U_n = 400, 440, 480\text{ V}$	2x 315 A aR	
<b>Characteristics</b>			
Efficiency at $I_n$		0.965	
Heat losses at $I_n$	Total losses	9910 W	7870 W
	Control part only	1160 W	920 W
Weight	Net	700 kg	
	Gross	755 kg	
<b>Ambient conditions</b>			
Air flow	Power part	2320 m <sup>3</sup> /h	
	Control part	280 m <sup>3</sup> /h	
Sound pressure level		73 dB(A)	
Rated short-circuit current $I_{sc}$	Minimum <sup>(3)</sup>	7 kA	
	Maximum <sup>(4)</sup>	50 kA (100 ms)	
<b>Mains and motor connection <sup>(5)</sup></b>			
Typical cable		2x (3x 150 mm <sup>2</sup> ) or 3x (3x 95 mm <sup>2</sup> )	2x (3x 120 mm <sup>2</sup> ) or 3x (3x 70 mm <sup>2</sup> )
Max. Cable cross section <sup>(6)</sup>	Cable	2x (3x 240 mm <sup>2</sup> ) or 4x (3x 185 mm <sup>2</sup> )	
	Cable entry <sup>(7)</sup>	max. 760 mm	
Terminals per phase		4x M12	
<p><b>(1)</b> For Heavy Duty HD operation parameter [Dual Rating] <i>drt</i> has to be set to [High rating] <i>HiGH</i> (see programming manual NHA80757).</p> <p><b>(2)</b> For details see table under chapter Mains Current Harmonics / Mains Voltage Distortion, page 87.</p> <p><b>(3)</b> Minimum mains short-circuit current</p> <p><b>(4)</b> Permitted short-circuit current when the specified pre-fuse or circuit breaker is installed</p> <p><b>(5)</b> You will find further information at chapter Mains Connection, page 84 and at chapter Motor Connection, page 88.</p> <p><b>(6)</b> Greater connection cross sections are possible with the separate connection enclosure.</p> <p><b>(7)</b> Maximum possible width of cables connected next to each other in the enclosure</p>			

## Dimensions IP23 for Size 2a

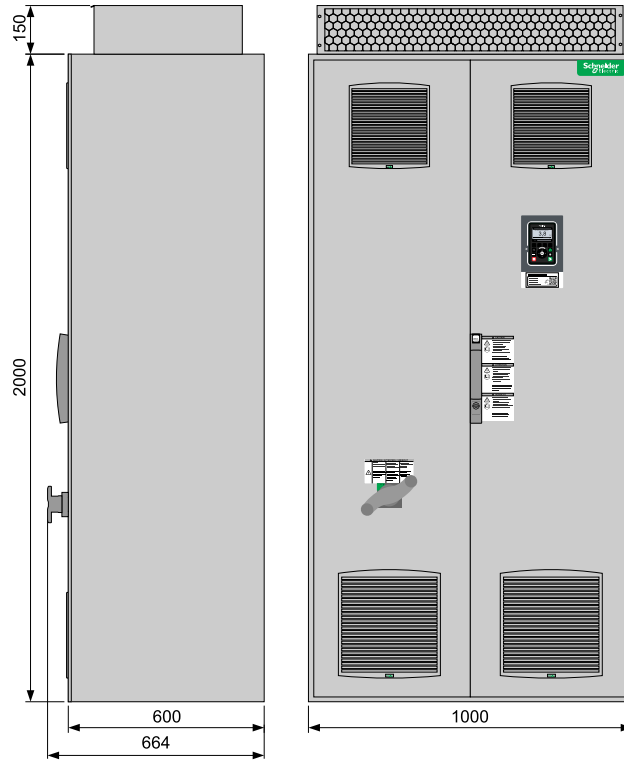

## Interior View IP23 for Size 2a

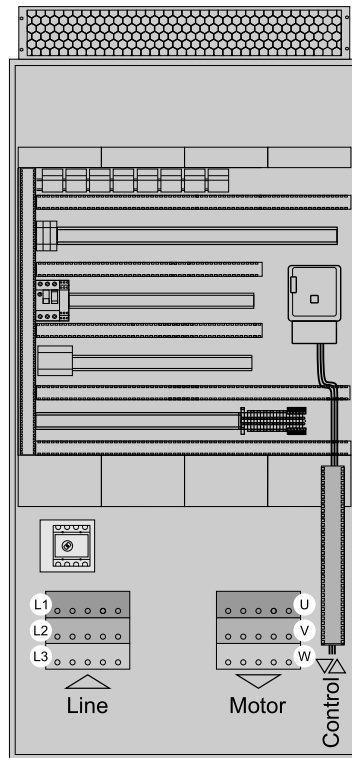

**NOTE:** Following customizations affect the total dimensions:

- Increased protection degree IP54
- Enclosure plinth for basic device
- Connection enclosure cable from top/ bottom
- Braking option BUO

# Technical Data ATV980C31•4X1

Type		ATV980C31•4X1	
Nominal data		Normal Duty ND	Heavy Duty HD <sup>(1)</sup>
Typical motor rating $P_n$	$U_n = 400\text{ V}$	315 kW	250 kW
	$U_n = 440\text{ V}$	315 kW	250 kW
	$U_n = 480\text{ V}$	355 kW	280 kW
Rated output current $I_n$		590 A	477 A
Maximum current $I_{MAX}$ for 60 s per 10 minutes		708 A	716 A
<b>Input</b>			
Rated input current $I_{in}$ (at $I_{sc} = 50\text{ kA}$ )	$U_n = 400\text{ V}$	491 A	389 A
	$U_n = 440\text{ V}$	446 A	354 A
	$U_n = 480\text{ V}$	461 A	363 A
Rated apparent power $S_n$	$U_n = 400\text{ V}$	340 kVA	270 kVA
	$U_n = 440\text{ V}$	340 kVA	270 kVA
	$U_n = 480\text{ V}$	383 kVA	302 kVA
Current harmonic THDi <sup>(2)</sup>		< 5 %	
<b>Protection for upstream cables</b>			
Pre-fuse	$U_n = 400, 440, 480\text{ V}$	630 A gG	500 A gG
Circuit breaker $I_{therm} / I_{magn}$		630 A / 6 kA	500 A / 6 kA
<b>Internal short-circuit protection</b>			
Fuse	$U_n = 400, 440, 480\text{ V}$	2x 400 A aR	
<b>Characteristics</b>			
Efficiency at $I_n$		0.965	
Heat losses at $I_n$	Total losses	13060 W	9890 W
	Control part only	1560 W	1140 W
Weight	Net	700 kg	
	Gross	755 kg	
<b>Ambient conditions</b>			
Air flow	Power part	2320 m <sup>3</sup> /h	
	Control part	280 m <sup>3</sup> /h	
Sound pressure level		73 dB(A)	
Rated short-circuit current $I_{sc}$	Minimum <sup>(3)</sup>	8 kA	
	Maximum <sup>(4)</sup>	50 kA (100 ms)	
<b>Mains and motor connection <sup>(5)</sup></b>			
Typical cable		2x (3x 185 mm <sup>2</sup> ) or 3x (3x 120 mm <sup>2</sup> )	2x (3x 150 mm <sup>2</sup> ) or 3x (3x 120 mm <sup>2</sup> )
Max. Cable cross section <sup>(6)</sup>	Cable	2x (3x 240 mm <sup>2</sup> ) or 4x (3x 185 mm <sup>2</sup> )	
	Cable entry <sup>(7)</sup>	max. 760 mm	
Terminals per phase		4x M12	
<p><b>(1)</b> For Heavy Duty HD operation parameter [Dual Rating] <i>drt</i> has to be set to [High rating] <i>HiGH</i> (see programming manual NHA80757).</p> <p><b>(2)</b> For details see table under chapter Mains Current Harmonics / Mains Voltage Distortion, page 87.</p> <p><b>(3)</b> Minimum mains short-circuit current</p> <p><b>(4)</b> Permitted short-circuit current when the specified pre-fuse or circuit breaker is installed</p> <p><b>(5)</b> You will find further information at chapter Mains Connection, page 84 and at chapter Motor Connection, page 88.</p> <p><b>(6)</b> Greater connection cross sections are possible with the separate connection enclosure.</p> <p><b>(7)</b> Maximum possible width of cables connected next to each other in the enclosure</p>			

## Dimensions IP23 for Size 2a

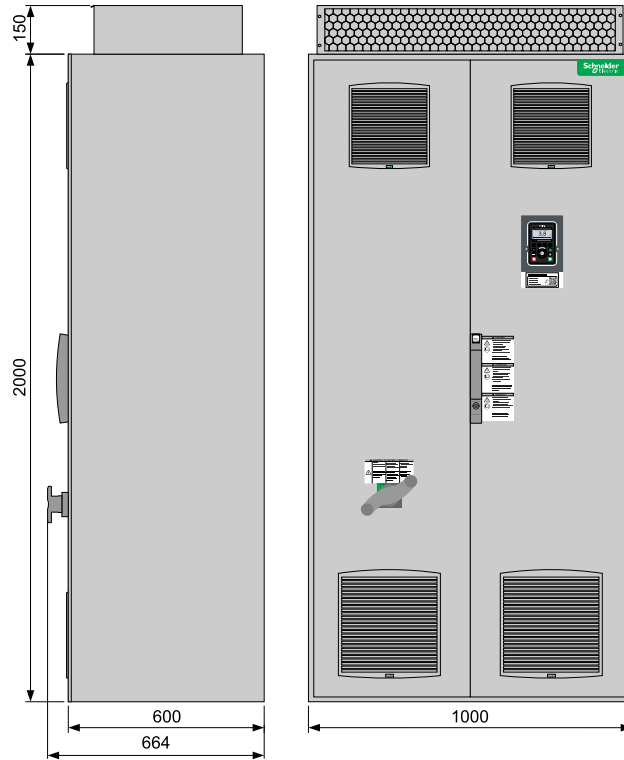

## Interior View IP23 for Size 2a

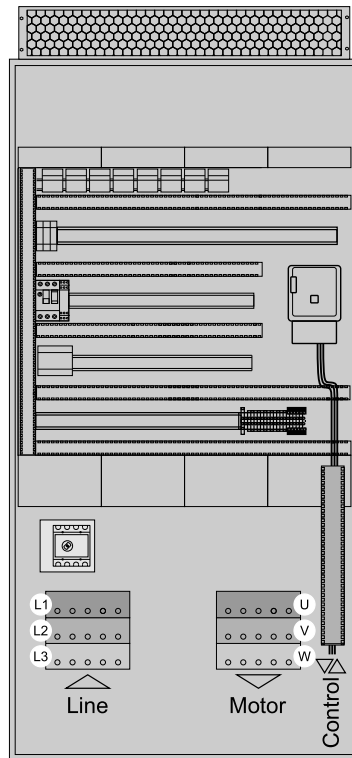

**NOTE:** Following customizations affect the total dimensions:

- Increased protection degree IP54
- Enclosure plinth for basic device
- Connection enclosure cable from top/ bottom
- Braking option BUO

# Technical Data ATV980C35•4X1

Type		ATV980C35•4X1	
Nominal data		Normal Duty ND	Heavy Duty HD <sup>(1)</sup>
Typical motor rating $P_n$	$U_n = 400\text{ V}$	355 kW	280 kW
	$U_n = 440\text{ V}$	355 kW	280 kW
	$U_n = 480\text{ V}$	400 kW	315 kW
Rated output current $I_n$		660 A	520 A
Maximum current $I_{MAX}$	for 60 s per 10 minutes	792 A	780 A
<b>Input</b>			
Rated input current $I_{in}$ (at $I_{sc} = 50\text{ kA}$ )	$U_n = 400\text{ V}$	553 A	436 A
	$U_n = 440\text{ V}$	503 A	396 A
	$U_n = 480\text{ V}$	519 A	409 A
Rated apparent power $S_n$	$U_n = 400\text{ V}$	383 kVA	302 kVA
	$U_n = 440\text{ V}$	383 kVA	302 kVA
	$U_n = 480\text{ V}$	432 kVA	340 kVA
Current harmonic THDi <sup>(2)</sup>		< 5 %	
<b>Protection for upstream cables</b>			
Pre-fuse	$U_n = 400, 440, 480\text{ V}$	800 A gG	630 A gG
Circuit breaker $I_{therm} / I_{magn}$		700 A / 7 kA	580 A / 7 kA
<b>Internal short-circuit protection</b>			
Fuse	$U_n = 400, 440, 480\text{ V}$	3x 315 A aR	
<b>Characteristics</b>			
Efficiency at $I_n$		0.965	
Heat losses at $I_n$	Total losses	13970 W	10990 W
	Control part only	1570 W	1240 W
Weight	Net	1150 kg	
	Gross	1220 kg	
<b>Ambient conditions</b>			
Air flow	Power part	3480 m <sup>3</sup> /h	
	Control part	420 m <sup>3</sup> /h	
Sound pressure level		75 dB(A)	
Rated short-circuit current $I_{sc}$	Minimum <sup>(3)</sup>	11 kA	
	Maximum <sup>(4)</sup>	50 kA (100 ms)	
<b>Mains and motor connection <sup>(5)</sup></b>			
Typical cable		3x (3x 150 mm <sup>2</sup> ) or 4x (3x 95 mm <sup>2</sup> )	2x (3x 185 mm <sup>2</sup> ) or 3x (3x 120 mm <sup>2</sup> )
Max. Cable cross section <sup>(6)</sup>	Cable	3x (3x 240 mm <sup>2</sup> ) or 4x (3x 185 mm <sup>2</sup> ) or 6x (3x 120 mm <sup>2</sup> )	
	Cable entry mains <sup>(7)</sup>	max. 360 mm	
	Cable entry motor <sup>(7)</sup>	max. 760 mm	
Terminals per phase		6x M12	
<p><b>(1)</b> For Heavy Duty HD operation parameter [Dual Rating] <i>drt</i> has to be set to [High rating] <i>HIGH</i> (see programming manual NHA80757).</p> <p><b>(2)</b> For details see table under chapter Mains Current Harmonics / Mains Voltage Distortion, page 87.</p> <p><b>(3)</b> Minimum mains short-circuit current</p> <p><b>(4)</b> Permitted short-circuit current when the specified pre-fuse or circuit breaker is installed</p> <p><b>(5)</b> You will find further information at chapter Mains Connection, page 84 and at chapter Motor Connection, page 88.</p> <p><b>(6)</b> Greater connection cross sections are possible with the separate connection enclosure.</p> <p><b>(7)</b> Maximum possible width of cables connected next to each other in the enclosure</p>			

## Dimensions IP23 for Size 3a

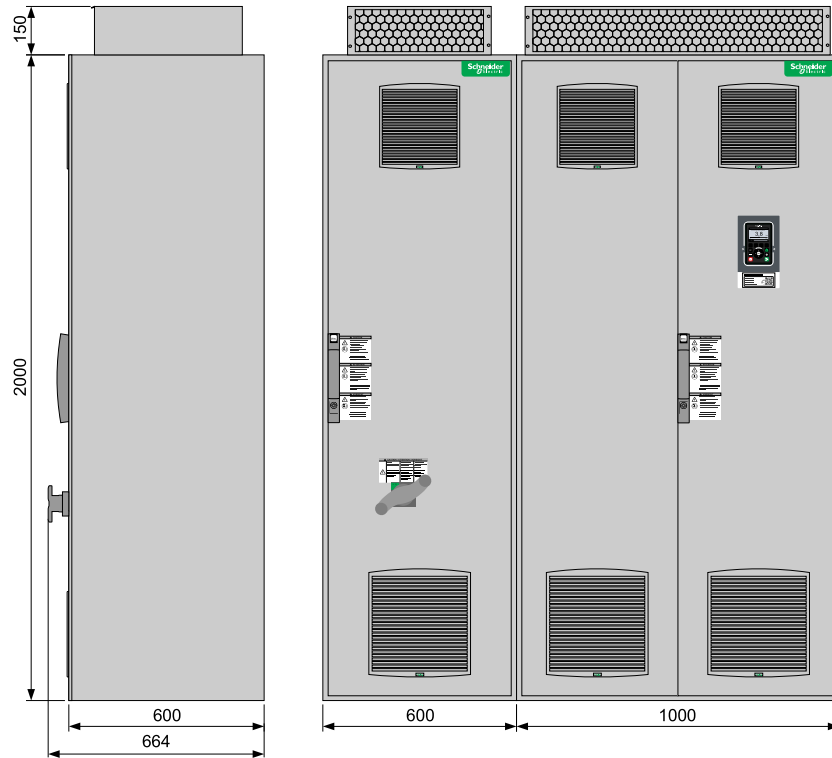

## Interior View IP23 for Size 3a

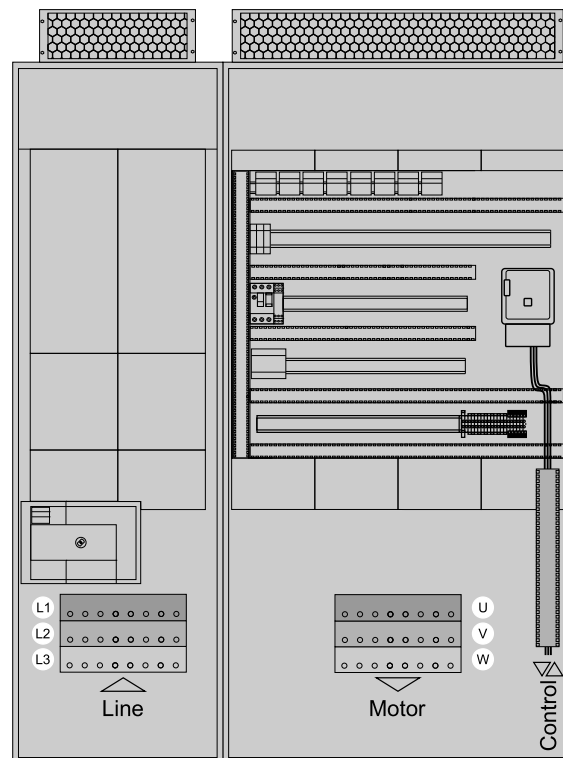

**NOTE:** Following customizations affect the total dimensions:

- Increased protection degree IP54
- Enclosure plinth for basic device
- Connection enclosure cable from top/ bottom
- Braking option BUO

# Technical Data ATV980C40•4X1

Type		ATV980C40•4X1	
Nominal data		Normal Duty ND	Heavy Duty HD <sup>(1)</sup>
Typical motor rating $P_n$	$U_n = 400\text{ V}$	400 kW	315 kW
	$U_n = 440\text{ V}$	400 kW	315 kW
	$U_n = 480\text{ V}$	450 kW	355 kW
Rated output current $I_n$		730 A	590 A
Maximum current $I_{MAX}$ for 60 s per 10 minutes		876 A	885 A
<b>Input</b>			
Rated input current $I_{in}$ (at $I_{sc} = 50\text{ kA}$ )	$U_n = 400\text{ V}$	620 A	491 A
	$U_n = 440\text{ V}$	563 A	446 A
	$U_n = 480\text{ V}$	581 A	461 A
Rated apparent power $S_n$	$U_n = 400\text{ V}$	429 kVA	340 kVA
	$U_n = 440\text{ V}$	429 kVA	340 kVA
	$U_n = 480\text{ V}$	483 kVA	383 kVA
Current harmonic THDi <sup>(2)</sup>		< 5 %	
<b>Protection for upstream cables</b>			
Pre-fuse	$U_n = 400, 440, 480\text{ V}$	800 A gG	630 A gG
Circuit breaker $I_{therm} / I_{magn}$		780 A / 8 kA	630 A / 8 kA
<b>Internal short-circuit protection</b>			
Fuse	$U_n = 400, 440, 480\text{ V}$	3x 315 A aR	
<b>Characteristics</b>			
Efficiency at $I_n$		0.965	
Heat losses at $I_n$	Total losses	15850 W	12300 W
	Control part only	1800 W	1400 W
Weight	Net	1150 kg	
	Gross	1220 kg	
<b>Ambient conditions</b>			
Air flow	Power part	3480 m <sup>3</sup> /h	
	Control part	420 m <sup>3</sup> /h	
Sound pressure level		75 dB(A)	
Rated short-circuit current $I_{sc}$	Minimum <sup>(3)</sup>	11 kA	
	Maximum <sup>(4)</sup>	50 kA (100 ms)	
<b>Mains and motor connection <sup>(5)</sup></b>			
Typical cable		3x (3x 185 mm <sup>2</sup> ) or 4x (3x 120 mm <sup>2</sup> )	3x (3x 120 mm <sup>2</sup> ) or 4x (3x 95 mm <sup>2</sup> )
Max. Cable cross section <sup>(6)</sup>	Cable	3x (3x 240 mm <sup>2</sup> ) or 4x (3x 185 mm <sup>2</sup> ) or 6x (3x 120 mm <sup>2</sup> )	
	Cable entry mains <sup>(7)</sup>	max. 360 mm	
	Cable entry motor <sup>(7)</sup>	max. 760 mm	
Terminals per phase		6x M12	
<p><b>(1)</b> For Heavy Duty HD operation parameter [Dual Rating] <i>drt</i> has to be set to [High rating] <i>HIGH</i> (see programming manual NHA80757).</p> <p><b>(2)</b> For details see table under chapter Mains Current Harmonics / Mains Voltage Distortion, page 87.</p> <p><b>(3)</b> Minimum mains short-circuit current</p> <p><b>(4)</b> Permitted short-circuit current when the specified pre-fuse or circuit breaker is installed</p> <p><b>(5)</b> You will find further information at chapter Mains Connection, page 84 and at chapter Motor Connection, page 88.</p> <p><b>(6)</b> Greater connection cross sections are possible with the separate connection enclosure.</p> <p><b>(7)</b> Maximum possible width of cables connected next to each other in the enclosure</p>			

## Dimensions IP23 for Size 3a

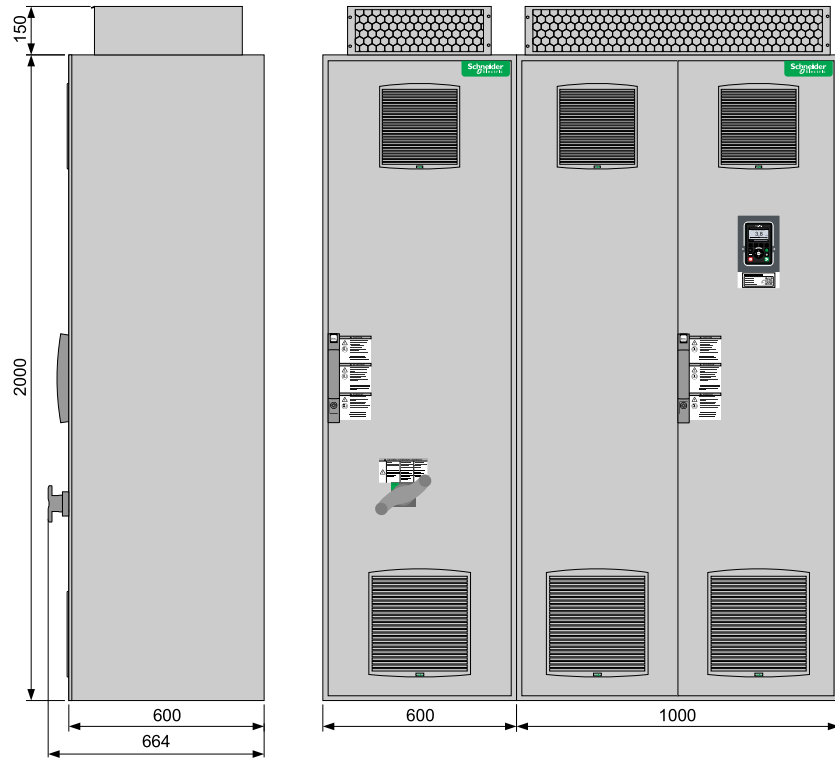

## Interior View IP23 for Size 3a

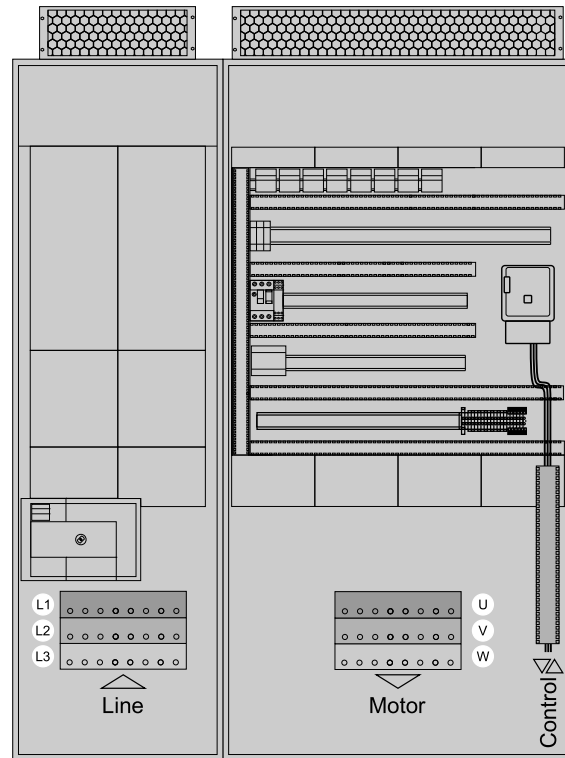

**NOTE:** Following customizations affect the total dimensions:

- Increased protection degree IP54
- Enclosure plinth for basic device
- Connection enclosure cable from top/ bottom
- Braking option BUO

# Technical Data ATV980C45•4X1

Type		ATV980C45•4X1	
Nominal data		Normal Duty ND	Heavy Duty HD <sup>(1)</sup>
Typical motor rating $P_n$	$U_n = 400\text{ V}$	450 kW	355 kW
	$U_n = 440\text{ V}$	450 kW	355 kW
	$U_n = 480\text{ V}$	500 kW	400 kW
Rated output current $I_n$		830 A	660 A
Maximum current $I_{MAX}$	for 60 s per 10 minutes	996 A	990 A
<b>Input</b>			
Rated input current $I_{in}$ (at $I_{sc} = 50\text{ kA}$ )	$U_n = 400\text{ V}$	697 A	553 A
	$U_n = 440\text{ V}$	634 A	503 A
	$U_n = 480\text{ V}$	646 A	519 A
Rated apparent power $S_n$	$U_n = 400\text{ V}$	483 kVA	383 kVA
	$U_n = 440\text{ V}$	483 kVA	383 kVA
	$U_n = 480\text{ V}$	537 kVA	432 kVA
Current harmonic THDi <sup>(2)</sup>		< 5 %	
<b>Protection for upstream cables</b>			
Pre-fuse	$U_n = 400, 440, 480\text{ V}$	1000 A gG	800 A gG
Circuit breaker $I_{therm} / I_{magn}$		900 A / 9 kA	720 A / 9 kA
<b>Internal short-circuit protection</b>			
Fuse	$U_n = 400, 440, 480\text{ V}$	3x 400 A aR	
<b>Characteristics</b>			
Efficiency at $I_n$		0.965	
Heat losses at $I_n$	Total losses	18210 W	13960 W
	Control part only	2060 W	1560 W
Weight	Net	1150 kg	
	Gross	1220 kg	
<b>Ambient conditions</b>			
Air flow	Power part	3480 m <sup>3</sup> /h	
	Control part	420 m <sup>3</sup> /h	
Sound pressure level		75 dB(A)	
Rated short-circuit current $I_{sc}$	Minimum <sup>(3)</sup>	13 kA	
	Maximum <sup>(4)</sup>	50 kA (100 ms)	
<b>Mains and motor connection <sup>(5)</sup></b>			
Typical cable		4x (3x 150 mm <sup>2</sup> ) or 5x (3x 120 mm <sup>2</sup> )	3x (3x 150 mm <sup>2</sup> ) or 4x (3x 95 mm <sup>2</sup> )
Max. Cable cross section <sup>(6)</sup>	Cable	3x (3x 240 mm <sup>2</sup> ) or 4x (3x 185 mm <sup>2</sup> ) or 6x (3x 120 mm <sup>2</sup> )	
	Cable entry mains <sup>(7)</sup>	max. 360 mm	
	Cable entry motor <sup>(7)</sup>	max. 760 mm	
Terminals per phase		6x M12	
<p><b>(1)</b> For Heavy Duty HD operation parameter [Dual Rating] <i>drt</i> has to be set to [High rating] <i>HIGH</i> (see programming manual NHA80757).</p> <p><b>(2)</b> For details see table under chapter Mains Current Harmonics / Mains Voltage Distortion, page 87.</p> <p><b>(3)</b> Minimum mains short-circuit current</p> <p><b>(4)</b> Permitted short-circuit current when the specified pre-fuse or circuit breaker is installed</p> <p><b>(5)</b> You will find further information at chapter Mains Connection, page 84 and at chapter Motor Connection, page 88.</p> <p><b>(6)</b> Greater connection cross sections are possible with the separate connection enclosure.</p> <p><b>(7)</b> Maximum possible width of cables connected next to each other in the enclosure</p>			

## Dimensions IP23 for Size 3a

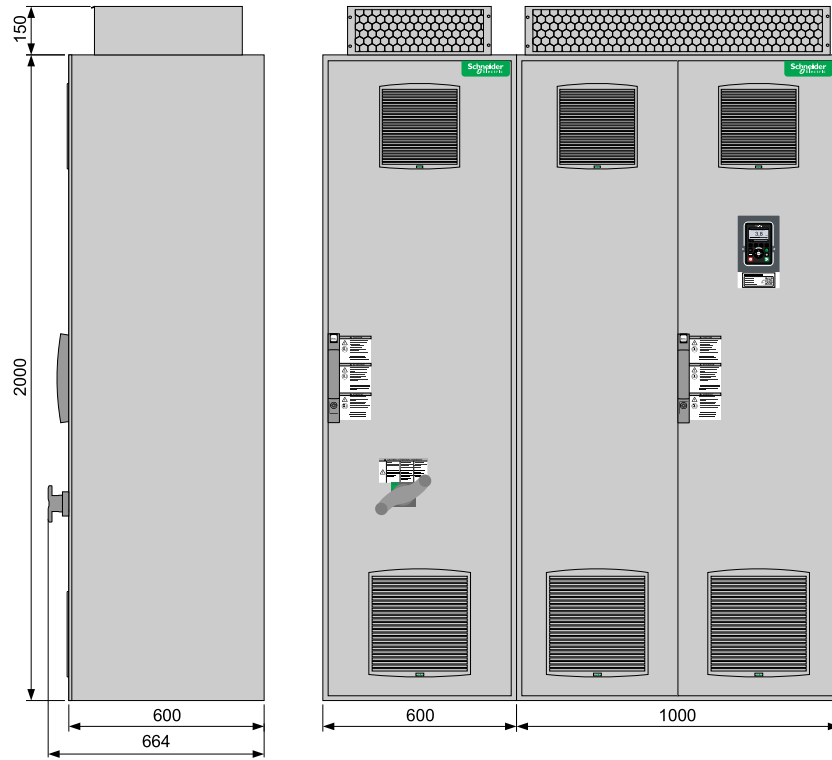

## Interior View IP23 for Size 3a

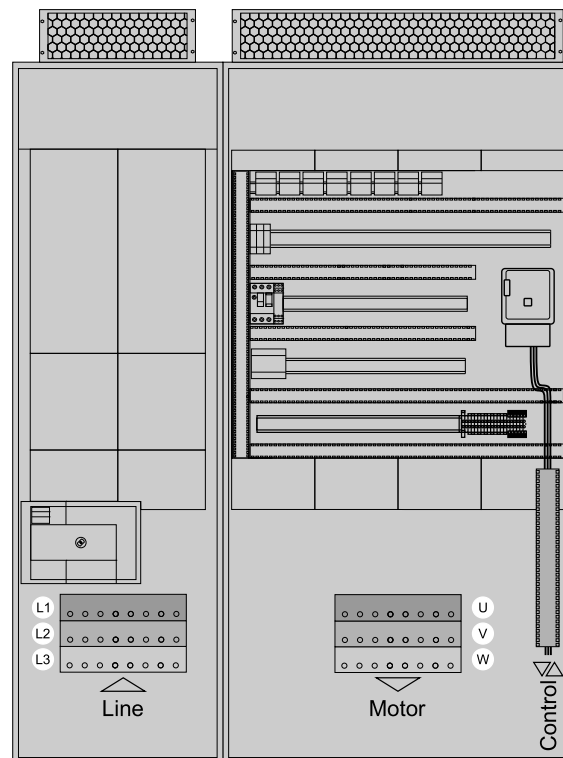

**NOTE:** Following customizations affect the total dimensions:

- Increased protection degree IP54
- Enclosure plinth for basic device
- Connection enclosure cable from top/ bottom
- Braking option BUO

# Technical Data ATV980C50•4X1

Type		ATV980C50•4X1	
Nominal data		Normal Duty ND	Heavy Duty HD <sup>(1)</sup>
Typical motor rating $P_n$	$U_n = 400\text{ V}$	500 kW	400 kW
	$U_n = 440\text{ V}$	500 kW	400 kW
	$U_n = 480\text{ V}$	560 kW	450 kW
Rated output current $I_n$		900 A	730 A
Maximum current $I_{MAX}$ for 60 s per 10 minutes		1080 A	1095 A
<b>Input</b>			
Rated input current $I_{in}$ (at $I_{sc} = 50\text{ kA}$ )	$U_n = 400\text{ V}$	775 A	620 A
	$U_n = 440\text{ V}$	704 A	563 A
	$U_n = 480\text{ V}$	723 A	581 A
Rated apparent power $S_n$	$U_n = 400\text{ V}$	537 kVA	429 kVA
	$U_n = 440\text{ V}$	537 kVA	429 kVA
	$U_n = 480\text{ V}$	601 kVA	483 kVA
Current harmonic THDi <sup>(2)</sup>		< 5 %	
<b>Protection for upstream cables</b>			
Pre-fuse	$U_n = 400, 440, 480\text{ V}$	1000 A gG	800 A gG
Circuit breaker $I_{therm} / I_{magn}$		1000 A / 10 kA	800 A / 10 kA
<b>Internal short-circuit protection</b>			
Fuse	$U_n = 400, 440, 480\text{ V}$	3x 400 A aR	
<b>Characteristics</b>			
Efficiency at $I_n$		0.965	
Heat losses at $I_n$	Total losses	20800 W	15830 W
	Control part only	2400 W	1780 W
Weight	Net	1150 kg	
	Gross	1220 kg	
<b>Ambient conditions</b>			
Air flow	Power part	3480 m <sup>3</sup> /h	
	Control part	420 m <sup>3</sup> /h	
Sound pressure level		75 dB(A)	
Rated short-circuit current $I_{sc}$	Minimum <sup>(3)</sup>	13 kA	
	Maximum <sup>(4)</sup>	50 kA (100 ms)	
<b>Mains and motor connection <sup>(5)</sup></b>			
Typical cable		4x (3x 185 mm <sup>2</sup> ) or 5x (3x 120 mm <sup>2</sup> )	3x (3x 185 mm <sup>2</sup> ) or 4x (3x 120 mm <sup>2</sup> )
Max. Cable cross section <sup>(6)</sup>	Cable	3x (3x 240 mm <sup>2</sup> ) or 4x (3x 185 mm <sup>2</sup> ) or 6x (3x 120 mm <sup>2</sup> )	
	Cable entry mains <sup>(7)</sup>	max. 360 mm	
	Cable entry motor <sup>(7)</sup>	max. 760 mm	
Terminals per phase		6x M12	
<p><b>(1)</b> For Heavy Duty HD operation parameter [Dual Rating] <i>drt</i> has to be set to [High rating] <i>HIGH</i> (see programming manual NHA80757).</p> <p><b>(2)</b> For details see table under chapter Mains Current Harmonics / Mains Voltage Distortion, page 87.</p> <p><b>(3)</b> Minimum mains short-circuit current</p> <p><b>(4)</b> Permitted short-circuit current when the specified pre-fuse or circuit breaker is installed</p> <p><b>(5)</b> You will find further information at chapter Mains Connection, page 84 and at chapter Motor Connection, page 88.</p> <p><b>(6)</b> Greater connection cross sections are possible with the separate connection enclosure.</p> <p><b>(7)</b> Maximum possible width of cables connected next to each other in the enclosure</p>			

## Dimensions IP23 for Size 3a

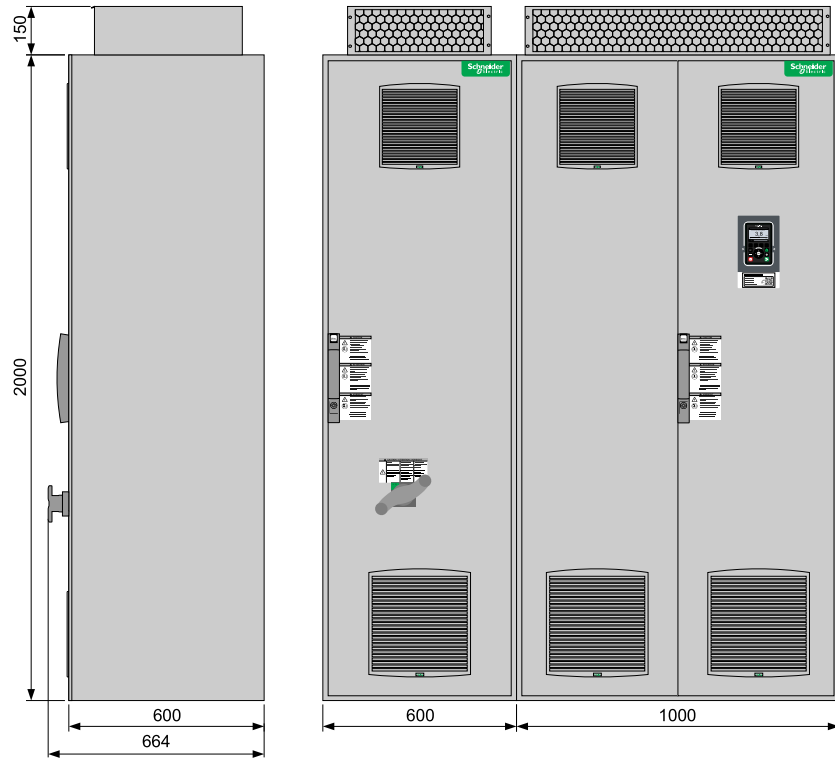

## Interior View IP23 for Size 3a

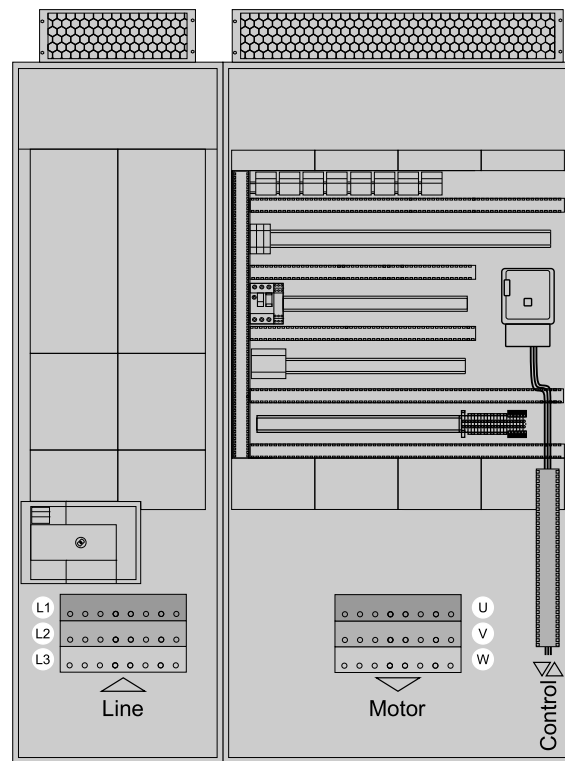

**NOTE:** Following customizations affect the total dimensions:

- Increased protection degree IP54
- Enclosure plinth for basic device
- Connection enclosure cable from top/ bottom
- Braking option BUO

# Technical Data ATV980C56•4X1

Type		ATV980C56•4X1	
Nominal data		Normal Duty ND	Heavy Duty HD <sup>(1)</sup>
Typical motor rating $P_n$	$U_n = 400\text{ V}$	560 kW	450 kW
	$U_n = 440\text{ V}$	560 kW	450 kW
	$U_n = 480\text{ V}$	630 kW	500 kW
Rated output current $I_n$		1020 A	830 A
Maximum current $I_{MAX}$ for 60 s per 10 minutes		1224 A	1245 A
<b>Input</b>			
Rated input current $I_{in}$ (at $I_{sc} = 50\text{ kA}$ )	$U_n = 400\text{ V}$	868 A	697 A
	$U_n = 440\text{ V}$	789 A	634 A
	$U_n = 480\text{ V}$	813 A	646 A
Rated apparent power $S_n$	$U_n = 400\text{ V}$	601 kVA	483 kVA
	$U_n = 440\text{ V}$	601 kVA	483 kVA
	$U_n = 480\text{ V}$	676 kVA	537 kVA
Current harmonic THDi <sup>(2)</sup>		< 5 %	
<b>Protection for upstream cables</b>			
Pre-fuse	$U_n = 400, 440, 480\text{ V}$	1250 A gG	1000 A gG
Circuit breaker $I_{therm} / I_{magn}$		1100 A / 11 kA	900 A / 11 kA
<b>Internal short-circuit protection</b>			
Fuse	$U_n = 400, 440, 480\text{ V}$	4x 400 A aR	
<b>Characteristics</b>			
Efficiency at $I_n$		0.965	
Heat losses at $I_n$	Total losses	22300 W	17480 W
	Control part only	2500 W	1930 W
Weight	Net	1450 kg	
	Gross	1530 kg	
<b>Ambient conditions</b>			
Air flow	Power part	4640 m <sup>3</sup> /h	
	Control part	560 m <sup>3</sup> /h	
Sound pressure level		77 dB(A)	
Rated short-circuit current $I_{sc}$	Minimum <sup>(3)</sup>	15 kA	
	Maximum <sup>(4)</sup>	50 kA (100 ms)	
<b>Mains and motor connection <sup>(5)</sup></b>			
Typical cable		4x (3x 185 mm <sup>2</sup> ) or 5x (3x 150 mm <sup>2</sup> )	4x (3x 150 mm <sup>2</sup> ) or 5x (3x 120 mm <sup>2</sup> )
Max. Cable cross section <sup>(6)</sup>	Cable	5x (3x 240 mm <sup>2</sup> ) or 6x (3x 185 mm <sup>2</sup> )	
	Cable entry mains <sup>(7)</sup>	max. 760 mm	
	Cable entry motor <sup>(7)</sup>	max. 760 mm	
Terminals per phase		8x M12	
<p><b>(1)</b> For Heavy Duty HD operation parameter [Dual Rating] <i>drt</i> has to be set to [High rating] <i>HiGH</i> (see programming manual NHA80757).</p> <p><b>(2)</b> For details see table under chapter Mains Current Harmonics / Mains Voltage Distortion, page 87.</p> <p><b>(3)</b> Minimum mains short-circuit current</p> <p><b>(4)</b> Permitted short-circuit current when the specified pre-fuse or circuit breaker is installed</p> <p><b>(5)</b> You will find further information at chapter Mains Connection, page 84 and at chapter Motor Connection, page 88.</p> <p><b>(6)</b> Greater connection cross sections are possible with the separate connection enclosure.</p> <p><b>(7)</b> Maximum possible width of cables connected next to each other in the enclosure</p>			

## Dimensions IP23 for Size 4a

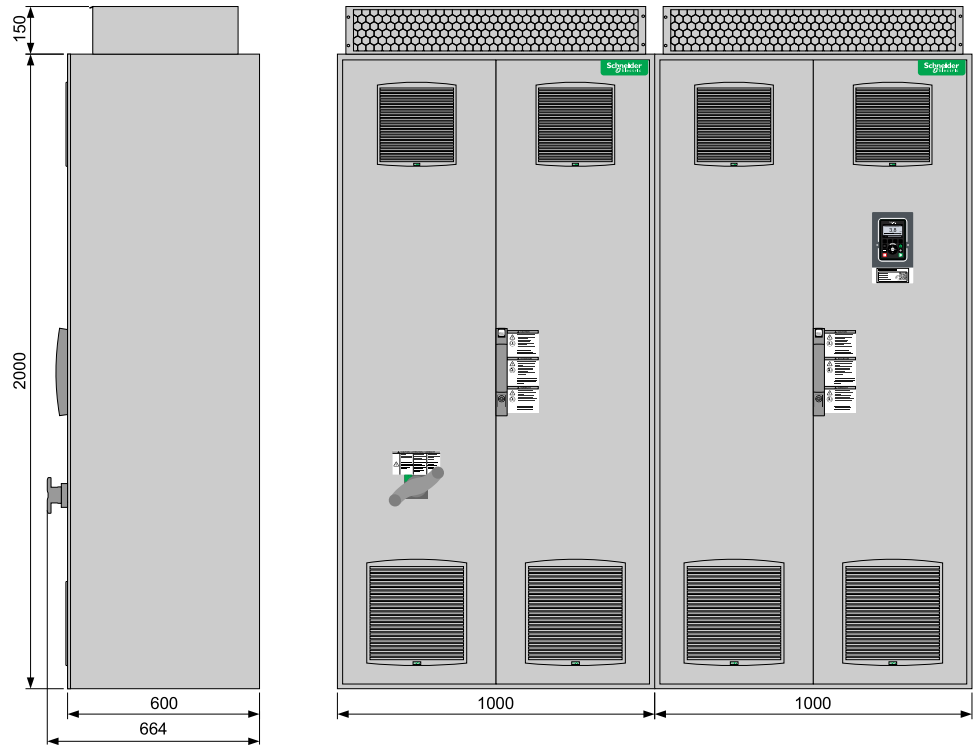

## Interior View IP23 for Size 4a

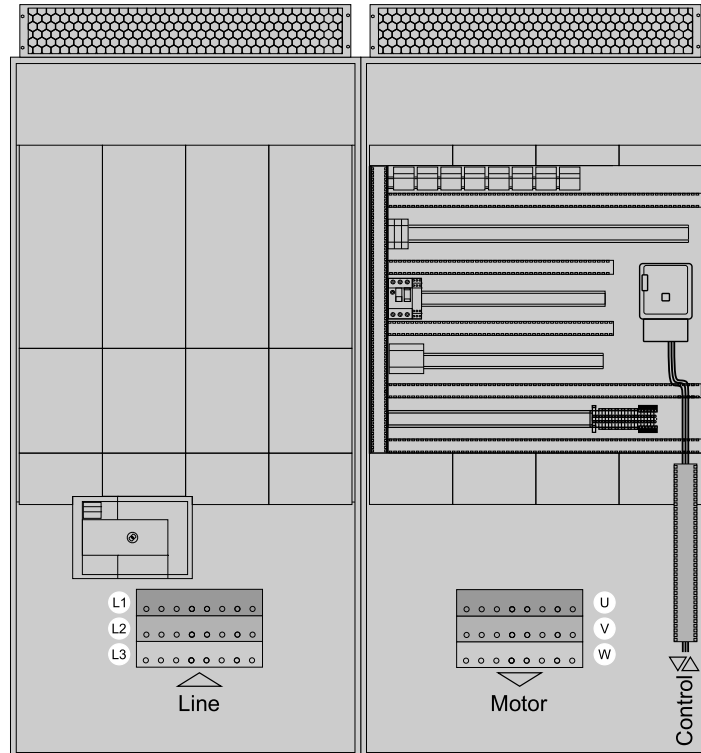

**NOTE:** Following customizations affect the total dimensions:

- Increased protection degree IP54
- Enclosure plinth for basic device
- Connection enclosure cable from top/ bottom
- Braking option BUO

# Technical Data ATV980C63•4X1

Type		ATV980C63•4X1	
Nominal data		Normal Duty ND	Heavy Duty HD <sup>(1)</sup>
Typical motor rating $P_n$	$U_n = 400\text{ V}$	630 kW	500 kW
	$U_n = 440\text{ V}$	630 kW	500 kW
	$U_n = 480\text{ V}$	710 kW	560 kW
Rated output current $I_n$		1140 A	900 A
Maximum current $I_{MAX}$ for 60 s per 10 minutes		1368 A	1350 A
<b>Input</b>			
Rated input current $I_{in}$ (at $I_{sc} = 50\text{ kA}$ )	$U_n = 400\text{ V}$	971 A	775 A
	$U_n = 440\text{ V}$	883 A	704 A
	$U_n = 480\text{ V}$	912 A	723 A
Rated apparent power $S_n$	$U_n = 400\text{ V}$	673 kVA	537 kVA
	$U_n = 440\text{ V}$	673 kVA	537 kVA
	$U_n = 480\text{ V}$	758 kVA	601 kVA
Current harmonic THDi <sup>(2)</sup>		< 5 %	
<b>Protection for upstream cables</b>			
Pre-fuse	$U_n = 400, 440, 480\text{ V}$	1250 A gG	1000 A gG
Circuit breaker $I_{therm} / I_{magn}$		1250 A / 12 kA	1000 A / 12 kA
<b>Internal short-circuit protection</b>			
Fuse	$U_n = 400, 440, 480\text{ V}$	4x 400 A aR	
<b>Characteristics</b>			
Efficiency at $I_n$		0.965	
Heat losses at $I_n$	Total losses	25630 W	19560 W
	Control part only	2930 W	2160 W
Weight	Net	1450 kg	
	Gross	1530 kg	
<b>Ambient conditions</b>			
Air flow	Power part	4640 m <sup>3</sup> /h	
	Control part	560 m <sup>3</sup> /h	
Sound pressure level		77 dB(A)	
Rated short-circuit current $I_{sc}$	Minimum <sup>(3)</sup>	17 kA	
	Maximum <sup>(4)</sup>	50 kA (100 ms)	
<b>Mains and motor connection <sup>(5)</sup></b>			
Typical cable		4x (3x 240 mm <sup>2</sup> ) or 5x (3x 185 mm <sup>2</sup> ) or 6x (3x 120 mm <sup>2</sup> )	4x (3x 185 mm <sup>2</sup> ) or 5x (3x 120 mm <sup>2</sup> )
Max. Cable cross section <sup>(6)</sup>	Cable	5x (3x 240 mm <sup>2</sup> ) or 6x (3x 185 mm <sup>2</sup> )	
	Cable entry mains <sup>(7)</sup>	max. 760 mm	
	Cable entry motor <sup>(7)</sup>	max. 760 mm	
Terminals per phase		8x M12	
<p><b>(1)</b> For Heavy Duty HD operation parameter [Dual Rating] <i>drt</i> has to be set to [High rating] <i>HiGH</i> (see programming manual NHA80757).</p> <p><b>(2)</b> For details see table under chapter Mains Current Harmonics / Mains Voltage Distortion, page 87.</p> <p><b>(3)</b> Minimum mains short-circuit current</p> <p><b>(4)</b> Permitted short-circuit current when the specified pre-fuse or circuit breaker is installed</p> <p><b>(5)</b> You will find further information at chapter Mains Connection, page 84 and at chapter Motor Connection, page 88.</p> <p><b>(6)</b> Greater connection cross sections are possible with the separate connection enclosure.</p> <p><b>(7)</b> Maximum possible width of cables connected next to each other in the enclosure</p>			

## Dimensions IP23 for Size 4a

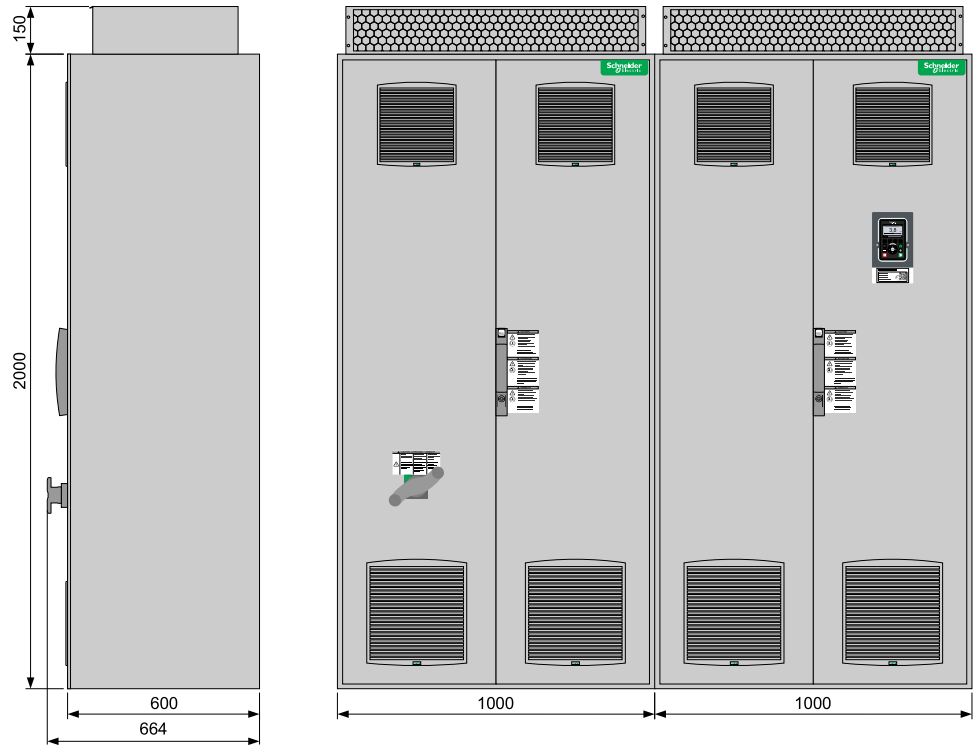

## Interior View IP23 for Size 4a

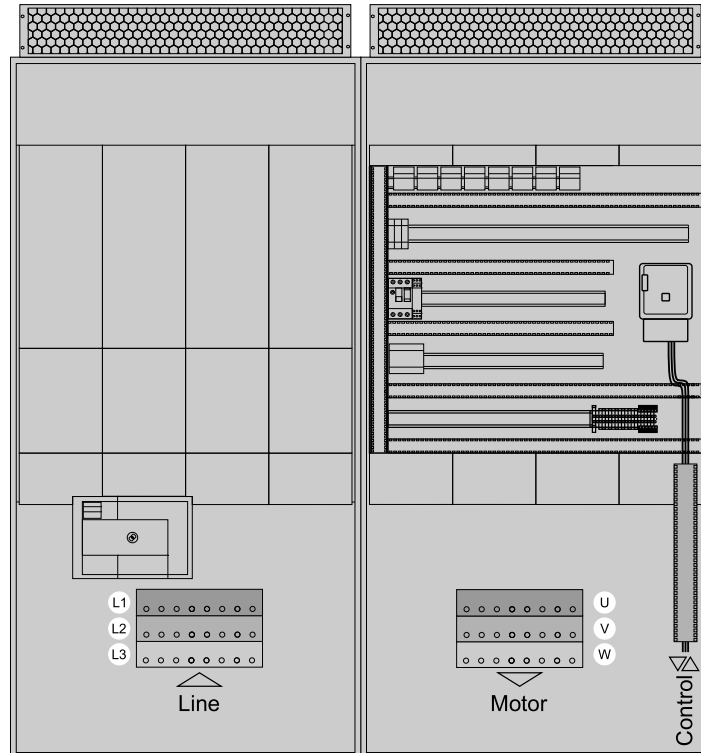

**NOTE:** Following customizations affect the total dimensions:

- Increased protection degree IP54
- Enclosure plinth for basic device
- Connection enclosure cable from top/ bottom
- Braking option BUO

# Technical Data ATV980C71•4X1

Type	ATV980C71•4X1		
Nominal data		Normal Duty ND	Heavy Duty HD <sup>(1)</sup>
Typical motor rating P <sub>n</sub>	U <sub>n</sub> = 400 V	710 kW	560 kW
	U <sub>n</sub> = 440 V	710 kW	560 kW
	U <sub>n</sub> = 480 V	800 kW	630 kW
Rated output current I <sub>n</sub>		1260 A	1020 A
Maximum current I <sub>MAX</sub>	for 60 s per 10 minutes	1512 A	1530 A
<b>Input</b>			
Rated input current I <sub>in</sub> (at I <sub>scc</sub> = 50 kA)	U <sub>n</sub> = 400 V	1094 A	868 A
	U <sub>n</sub> = 440 V	995 A	789 A
	U <sub>n</sub> = 480 V	1028 A	813 A
Rated apparent power S <sub>n</sub>	U <sub>n</sub> = 400 V	758 kVA	601 kVA
	U <sub>n</sub> = 440 V	758 kVA	601 kVA
	U <sub>n</sub> = 480 V	854 kVA	676 kVA
Current harmonic THDi <sup>(2)</sup>		< 5 %	
<b>Protection for upstream cables</b>			
Pre-fuse	U <sub>n</sub> = 400, 440, 480 V	1600 A gG	1250 A gG
Circuit breaker I <sub>therm</sub> / I <sub>magn</sub>		1400 A / 14 kA	1100 A / 14 kA
<b>Internal short-circuit protection</b>			
Fuse	U <sub>n</sub> = 400, 440, 480 V	5x 400 A aR	
<b>Characteristics</b>			
Efficiency at I <sub>n</sub>		0.965	
Heat losses at I <sub>n</sub>	Total losses	28230 W	21850 W
	Control part only	3230 W	2450 W
Weight	Net	1950 kg	
	Gross	2045 kg	
<b>Ambient conditions</b>			
Air flow	Power part	5800 m <sup>3</sup> /h	
	Control part	700 m <sup>3</sup> /h	
Sound pressure level		78 dB(A)	
Rated short-circuit current I <sub>scc</sub>	Minimum <sup>(3)</sup>	18 kA	
	Maximum <sup>(4)</sup>	50 kA (100 ms)	
<b>Mains and motor connection <sup>(5)</sup></b>			
Typical cable		5x (3x 185 mm <sup>2</sup> ) or 6x (3x 150 mm <sup>2</sup> )	4x (3x 185 mm <sup>2</sup> ) or 5x (3x 150 mm <sup>2</sup> )
Max. Cable cross section <sup>(6)</sup>	Cable	6x (3x 240 mm <sup>2</sup> ) or 8x (3x 150 mm <sup>2</sup> )	
	Cable entry mains <sup>(7)</sup>	max. 760 mm	
	Cable entry motor <sup>(7)</sup>	max. 760 mm	
Terminals per phase		10x M12	
<p><b>(1)</b> For Heavy Duty HD operation parameter [Dual Rating] <i>drt</i> has to be set to [High rating] <i>HiGH</i> (see programming manual NHA80757).</p> <p><b>(2)</b> For details see table under chapter Mains Current Harmonics / Mains Voltage Distortion, page 87.</p> <p><b>(3)</b> Minimum mains short-circuit current</p> <p><b>(4)</b> Permitted short-circuit current when the specified pre-fuse or circuit breaker is installed</p> <p><b>(5)</b> You will find further information at chapter Mains Connection, page 84 and at chapter Motor Connection, page 88.</p> <p><b>(6)</b> Greater connection cross sections are possible with the separate connection enclosure.</p> <p><b>(7)</b> Maximum possible width of cables connected next to each other in the enclosure</p>			

## Dimensions IP23 for Size 5a

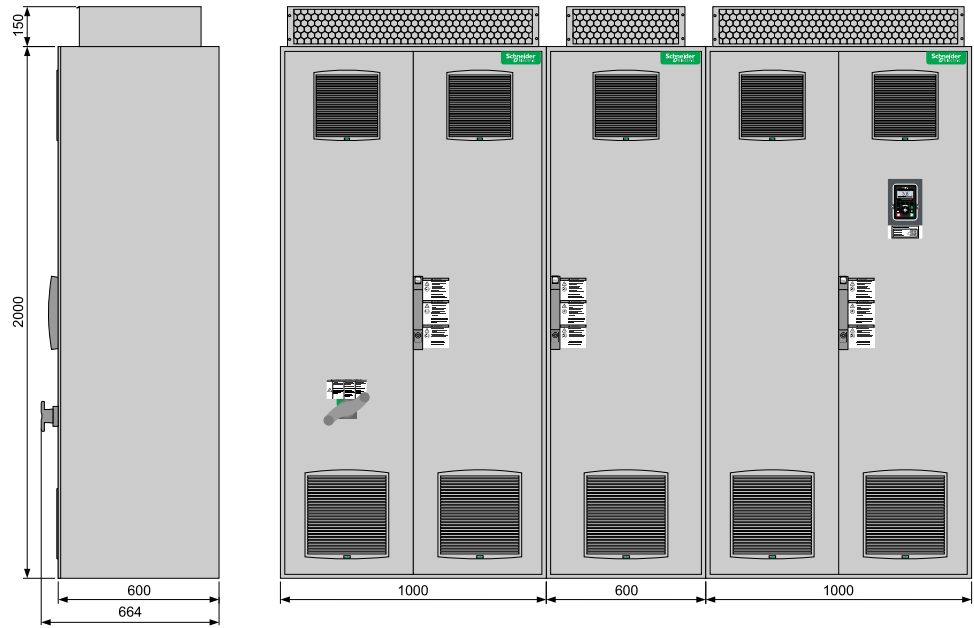

## Interior View IP23 for Size 5a

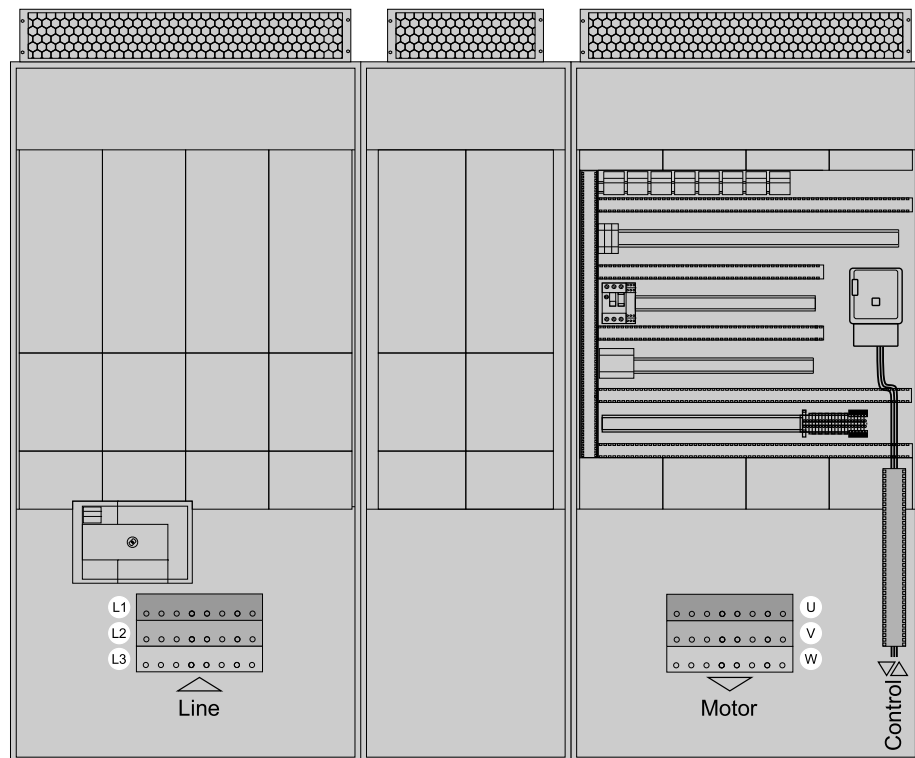

**NOTE:** Following customizations affect the total dimensions:

- Increased protection degree IP54
- Enclosure plinth for basic device
- Connection enclosure cable from top/ bottom
- Braking option BUO

# Technical Data ATV980C80•4X1

Type		ATV980C80•4X1	
Nominal data		Normal Duty ND	Heavy Duty HD <sup>(1)</sup>
Typical motor rating $P_n$	$U_n = 400\text{ V}$	800 kW	630 kW
	$U_n = 440\text{ V}$	800 kW	630 kW
	$U_n = 480\text{ V}$	900 kW	710 kW
Rated output current $I_n$		1420 A	1140 A
Maximum current $I_{MAX}$ for 60 s per 10 minutes		1704 A	1710 A
<b>Input</b>			
Rated input current $I_{in}$ (at $I_{sc} = 50\text{ kA}$ )	$U_n = 400\text{ V}$	1227 A	971 A
	$U_n = 440\text{ V}$	1115 A	883 A
	$U_n = 480\text{ V}$	1150 A	912 A
Rated apparent power $S_n$	$U_n = 400\text{ V}$	850 kVA	673 kVA
	$U_n = 440\text{ V}$	850 kVA	673 kVA
	$U_n = 480\text{ V}$	956 kVA	758 kVA
Current harmonic THDi <sup>(2)</sup>		< 5 %	
<b>Protection for upstream cables</b>			
Pre-fuse	$U_n = 400, 440, 480\text{ V}$	1600 A gG	1250 A gG
Circuit breaker $I_{therm} / I_{magn}$		1600 A / 16 kA	1250 A / 16 kA
<b>Internal short-circuit protection</b>			
Fuse	$U_n = 400, 440, 480\text{ V}$	5x 400 A aR	
<b>Characteristics</b>			
Efficiency at $I_n$		0.965	
Heat losses at $I_n$	Total losses	32580 W	24580 W
	Control part only	3780 W	2780 W
Weight	Net	1950 kg	
	Gross	2045 kg	
<b>Ambient conditions</b>			
Air flow	Power part	5800 m <sup>3</sup> /h	
	Control part	700 m <sup>3</sup> /h	
Sound pressure level		78 dB(A)	
Rated short-circuit current $I_{sc}$	Minimum <sup>(3)</sup>	20 kA	
	Maximum <sup>(4)</sup>	50 kA (100 ms)	
<b>Mains and motor connection <sup>(5)</sup></b>			
Typical cable		5x (3x 240 mm <sup>2</sup> ) or 6x (3x 185 mm <sup>2</sup> )	4x (3x 240 mm <sup>2</sup> ) or 5x (3x 185 mm <sup>2</sup> ) or 6x (3x 120 mm <sup>2</sup> )
Max. Cable cross section <sup>(6)</sup>	Cable	6x (3x 240 mm <sup>2</sup> ) or 8x (3x 150 mm <sup>2</sup> )	
	Cable entry mains <sup>(7)</sup>	max. 760 mm	
	Cable entry motor <sup>(7)</sup>	max. 760 mm	
Terminals per phase		10x M12	
<p><b>(1)</b> For Heavy Duty HD operation parameter [Dual Rating] <i>drt</i> has to be set to [High rating] <i>HiGH</i> (see programming manual NHA80757).</p> <p><b>(2)</b> For details see table under chapter Mains Current Harmonics / Mains Voltage Distortion, page 87.</p> <p><b>(3)</b> Minimum mains short-circuit current</p> <p><b>(4)</b> Permitted short-circuit current when the specified pre-fuse or circuit breaker is installed</p> <p><b>(5)</b> You will find further information at chapter Mains Connection, page 84 and at chapter Motor Connection, page 88.</p> <p><b>(6)</b> Greater connection cross sections are possible with the separate connection enclosure.</p> <p><b>(7)</b> Maximum possible width of cables connected next to each other in the enclosure</p>			

## Dimensions IP23 for Size 5a

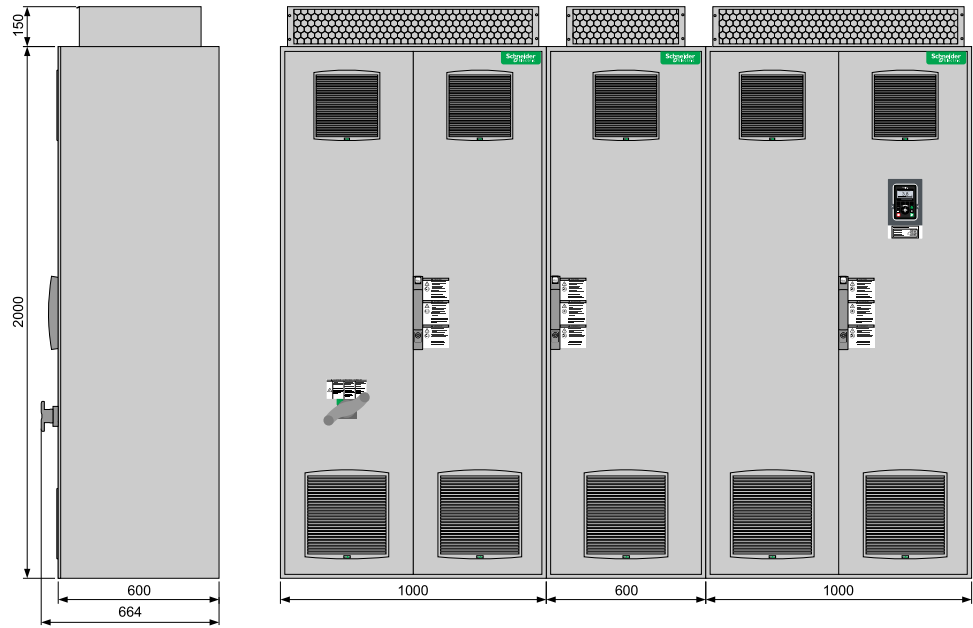

## Interior View IP23 for Size 5a

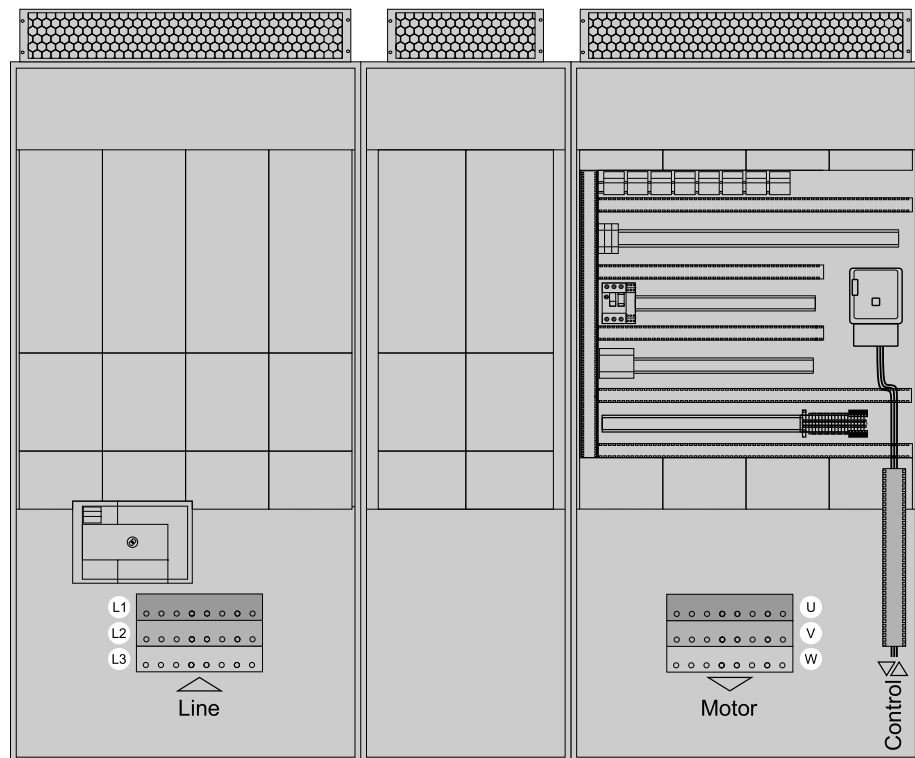

**NOTE:** Following customizations affect the total dimensions:

- Increased protection degree IP54
- Enclosure plinth for basic device
- Connection enclosure cable from top/ bottom
- Braking option BUO

# Circuit Diagram

The following diagram shows the typical wiring of the frequency inverter including the options which may be required for protection of the plant or the device, depending on the use case.

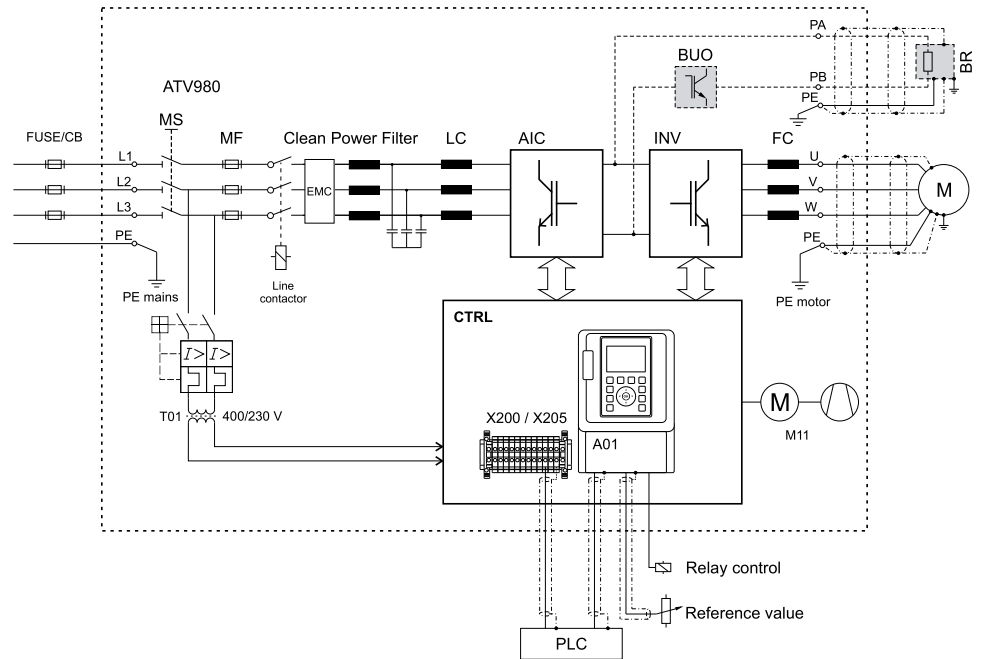

- ATV980**            Altivar Process Drive Systems
- FUSE/CB**        External pre-fuse or circuit breaker to protect the mains cable
- MS**                Built-in main switch, lockable in open position
- T01**                Control transformer 400 / 230 V AC
- MF**                aR fuses for short-circuit shut-down if the electronic protective devices do not work properly
- Clean Power Filter**    Clean Power Filter with integrated EMC filter
- LC**                Filter choke
- AIC**                Active Infeed Converter module(s)
- INV**                Inverter module(s)
- FC**                dv/dt filter choke to reduce the voltage load of the motor (at some types a "dv/dt filter choke" is already integrated)
- CTRL**             Control panel with control block and further control components
- A01**                Control terminals at the control block
- X200 / X205**    Control terminals at the control panel
- M11**                Fan in enclosure door
- BUO**                Braking unit option
- BR**                Braking resistor (option)

# Mains Connection

## What's in This Chapter

Dimensioning of the Power Cables .....	85
Overcurrent- and Short-circuit Protection .....	86
Mains Current Harmonics / Mains Voltage Distortion .....	87



## Dimensioning of the Power Cables

The Altivar Process Drive Systems include semiconductor fuses as standard. These fuses are for the case that the electronic protective mechanisms of the inverter do not work. So they are a secondary protection of the inverter.

The Altivar Process Drive Systems help to protect themselves as well as the mains cables and the motor cables against thermal overload. The specified pre-fuses or circuit breakers (with magnetic release) must be installed upstream to protect the mains cables against short-circuit.

The recommended values for dimensioning the cable cross sections given in chapter Specification, page 54 are reference values for multi-core copper power cables laid in air at a maximum ambient temperature of 40°C (104°F). Observe different ambient conditions and local regulations.

### Recommended types of mains cables

Cable Type	Description
	Three-phase cable with sector-shaped conductors and reduced protective conductor. <b>NOTE:</b> Verify that the PE conductor complies with the requirements according to IEC 61439-1.
	Three-phase cable with round conductors and reduced protective conductor. <b>NOTE:</b> Verify that the PE conductor complies with the requirements according to IEC 61439-1.

## ⚠ WARNING

### OVERLOAD DUE TO INCORRECT RATING OF MAINS SUPPLY

- Install properly rated upstream mains fuses or circuit breakers.
- When rating the upstream mains fuses and the cross sections as well as the lengths of the mains cables, take into account the available specified short circuit current.
- If the required short circuit is not available, increase the power of the transformer.

**Failure to follow these instructions can result in death, serious injury, or equipment damage.**

# Overcurrent- and Short-circuit Protection

The following picture illustrates the overcurrent protection and short-circuit protection at the input side.

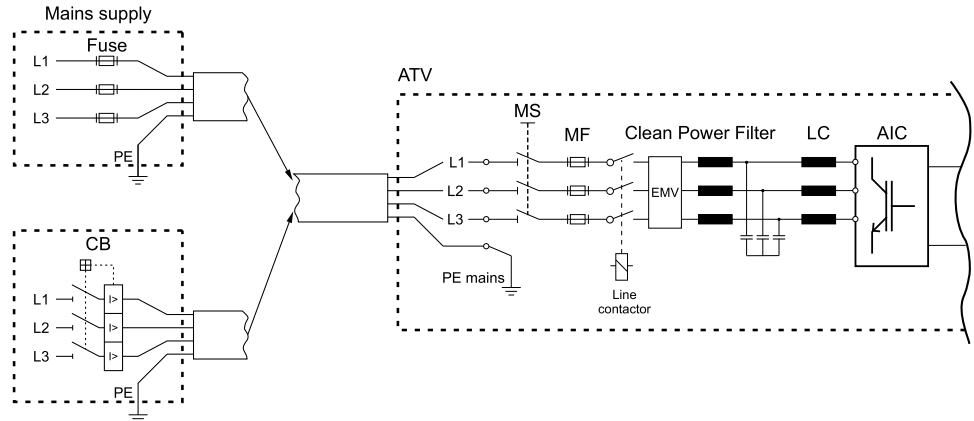

- ATV**                      Altivar Process Drive Systems
- FUSE**                    External pre-fuse to protect the mains cable
- CB**                        External circuit breaker to protect the mains cable (alternatively to FUSE)
- MS**                        Built-in main switch, lockable in open position
- MF**                        aR mains fuses for short-circuit shut-down if the electronic protective devices do not work properly
- Clean Power Filter**    Clean Power Filter with integrated EMC filter
- LC**                        Filter choke
- AIC**                        Active Infeed Converter module(s)

The Altivar Process Drive System includes semiconductor fuses as standard. These fuses are for the case that the electronic protective mechanisms of the inverter do not work. So they are a secondary protection of the inverter.

The opening of the branch circuit protective device may be an indication that a fault current has been interrupted.

⚡ ⚠ **DANGER**

HAZARD OF ELECTRIC SHOCK, EXPLOSION, OR ARC FLASH

Current-carrying parts and other components of the controller should be examined and replaced if damaged before switching the system on again.

Failure to follow these instructions will result in death or serious injury.

**NOTE:** The overcurrent protection is given at the technical data of the respective Altivar Process Drive System, page 54.

## Mains Current Harmonics / Mains Voltage Distortion

Because of using a diode rectifier on the input of a conventional inverter, harmonics occur in the mains current which lead to a voltage distortion of the supplying mains.

The ATV980 Regenerative Drive Systems are equipped with an active mains supply module. So these typical harmonic currents of the frequency inverter do not occur anymore.

The new 3-level technology inside the ATV980 Regenerative Drive System reaches a total harmonic distortion THD(i) of around 2 % and thus fulfills the requirements according to IEEE 519 of  $THD(i) < 5\%$  also in case of distorted mains. This low total harmonic distortion THD(i) is reached during mains supply operation as well as during regenerating operation.

$\cos \Phi \approx 1$  is reached in each load situation (from 30 % P<sub>n</sub>) and additionally helps to reduce the load of the mains.

This table represents typical values of the individual current harmonics at operation with the ATV980 Regenerative Drive Systems.

Operating mode	Current harmonics in % <sup>(1)</sup>																	
	H1	H5	H7	H11	H13	H17	H19	H23	H25	H29	H31	H35	H37	H41	H43	H47	H49	THD
<b>Motor</b>	<b>100</b>	1.29	1.05	0.38	0.21	0.20	0.19	0.34	0.19	0.11	0.09	0.15	0.12	0.19	0.18	0.07	0.04	<b>2.2</b>
<b>Generator</b>	<b>100</b>	1.26	0.78	0.39	0.33	0.69	0.60	0.28	0.40	0.22	0.22	0.16	0.20	0.18	0.09	0.04	0.04	<b>2.1</b>

**(1)** Values are valid for operation at nominal load and sinusoidal mains voltage.

# Motor Connection

## What's in This Chapter

Assignment of the Motor .....	89
Dimensioning of the Motor Cables .....	90
Length of Motor Cables .....	91
Thermal Motor Monitoring .....	95

# Assignment of the Motor

All Altivar Process Drive Systems include the function "Dual rating". It enables the use for drives with low overload "Normal duty" (typically pumps and fans) and, on the other hand, also the use with increased requirements regarding overload capability, starting torque, load impacts and control performance "Heavy duty" (e.g. compressors, mixers, rotary blowers,...).

You can select the desired power/overload capability with parameter **[Dual rating] DRT**. When changing this parameter all relevant parameters are adapted to the selected property. For example, the parameters for motor power and motor current are modified accordingly.

In case of setting HD – Heavy Duty **[High rating] HIGH** the overload capability and the maximum overload current are increased. But at the same time the nominal motor power and the continuous output current of the frequency inverter are reduced. So you have to select a higher device type for the same motor power.

### Example for ATV980C13Q4X1:

#### Normal Duty ND:

132 kW with 250 A continuous current and 300 A overload current for 60 s

- Nominal power
- Overload 20 %
- Factory setting: **[Normal rating] NORMAL**

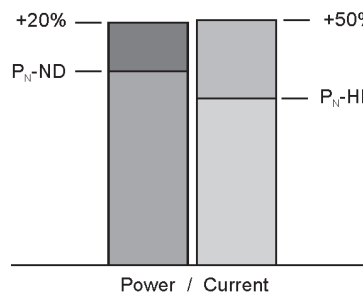

#### Heavy Duty HD:

110 kW with 211 A continuous current and 317 A overload current for 60 s

- Lower nominal power
- Overload 50 %
- Selectable via parameter: **[High rating] HIGH**

The factory setting of the parameter **[Dual rating] DRT** is "Normal Duty". When the product is reset to the factory settings, this parameter is also reset to "Normal Duty".

## Dimensioning of the Motor Cables

 **DANGER**

**ELECTRIC SHOCK DUE TO OVERLOAD ON MOTOR CABLES**

- Verify that the protective ground conductor complies with the requirements specified in IEC 61439-1.
- Verify compliance of the motor cables with the specification of IEC 60034-25.



**Failure to follow these instructions will result in death or serious injury.**

The recommended values for dimensioning the cable cross sections given in chapter Specification, page 54 are reference values for multi-core copper power cables laid in air at a maximum ambient temperature of 40°C (104°F). Observe different ambient conditions and local regulations.

The motor cables are dimensioned for the maximum continuous current. They apply to 0...100 Hz (up to 300 Hz the cable losses increase about 25 % because of the Skin-effect).

The IGBT modules cause high-frequent interferences which drain off more and more stronger to the ground potential with increasing motor cable length. As a result the line-conducted interferences to the mains increase. In case of too long motor cables the attenuation of the mains filters is not longer sufficient and the permitted interference limits are exceeded.

### Recommended types of motor cables

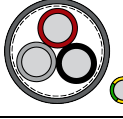
Cable Type	Description
	Symmetrically shielded cable with 3 phase conductors, symmetrically arranged PE conductor and a shield. <b>NOTE:</b> Verify that the PE conductor complies with the requirements according to IEC 61439-1. Example: 2YSLCY-JB
	Symmetrically shielded cable with 3 phase conductors and a concentric PE conductor as shield. <b>NOTE:</b> Verify that the PE conductor complies with the requirements according to IEC 61439-1. Example: NYCY / NYCWY
	Three-phase cable with round conductors and reduced protective conductor. <b>NOTE:</b> A separate PE conductor is required if the shield does not fulfill the requirements according to IEC 61439-1.

**NOTE:** Shielded single-conductor cables are not recommended due to increased currents in the shield.

# Length of Motor Cables

Because of the permitted mains disturbances, the allowed overvoltages at the motor, the occurring bearing currents and the permitted heat losses the distance between inverter and motor(s) is limited. The maximum distance heavily depends on the used motors (insulation material), the type of motor cable used (shielded/unshielded), the cable laying (cable channel, underground installation, ...) as well as from the used options.

## Dynamic voltage load of the motor

Overvoltages at the motor terminals result from reflection in the motor cable. Basically the motors are stressed with measurable higher voltage peaks from a motor cable length of 10 m. With the length of the motor cable also the value of overvoltage increases.

The steep edges of the switching impulses at the output side of the frequency inverter lead to a further load of the motors. The slew rate of the voltage is typically over 5 kV/μs but it decreases with the length of the motor cable.

The ATV980 frequency inverters are equipped with a dv/dt filter choke (at higher types a "dv/dt filter choke" is already integrated), which significantly reduces the load of the motors and so it is in accordance with the allowed limits.

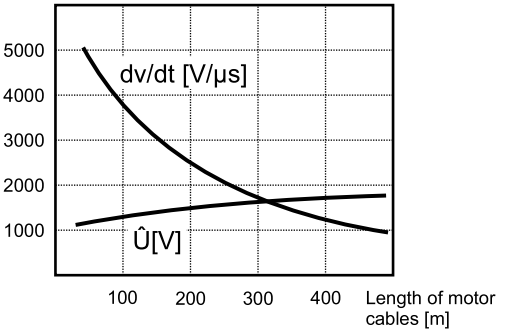
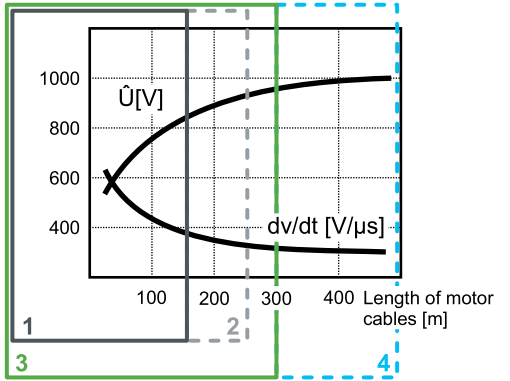
Typical load of the motor <sup>(1)</sup>	Description
	<p>Load of the motor with overvoltage and slew rate when using conventional frequency inverters without integrated dv/dt filter chokes.</p>
	<p>Reduced load of the motor by using Altivar Process Drive Systems with integrated dv/dt filter chokes 150 m (at higher types a "dv/dt filter choke" is already integrated).</p> <ol style="list-style-type: none"> <li>1 When using a shielded motor cable</li> <li>2 When using an unshielded motor cable</li> <li>3 When using a shielded motor cable and a "dv/dt filter choke 300 m".</li> <li>4 When using an unshielded motor cable and a "dv/dt filter choke 300 m".</li> </ol>
<p>(1) The given values are related to the voltage load phase-to-phase. The voltage values phase to ground are approximately 300 V lower, du/dt is approximately 150 V/μs lower.</p>	

The motor standards for IEC and NEMA specify limits for the permitted load regarding slew rate and voltage peaks

- IEC 60034-17 – Permitted values for standard power supply driven motors at the frequency inverter, up to 500 V
- IEC 60034-25 – Permitted values for "inverter motors" up to 500 V
- NEMA MG1 – Permitted values for "inverter motors"

Typical measured values	Description
<p>The graph plots dv/dt [kV] on the y-axis (0.5 to 2.0) against time t<sub>r</sub> [μs] on the x-axis (0.2 to 1.0). Three curves represent different standards: IEC60034-25 (highest dv/dt), IEC60034-17 (middle), and NEMA MG1 (lowest). Cable lengths of 5m, 20m, 30m, 50m, and 100m are marked with green 'x' symbols. Voltage levels of 1.2kV, 1.35kV, and 1.56kV are also indicated.</p>	<p>The typical measured values as shown in the diagram correspond with the ATV980 frequency inverter variant with built-in dv/dt filter choke 150 m (at higher types a "dv/dt filter choke" is already integrated).</p>

Motors according IEC 60034-25 as well as motors according NEMA MG1 are dimensioned for operation with frequency inverters and thus they are well qualified for drives with ATV980 frequency inverters.

Motors according IEC 60034-17 are dimensioned for operation with pure sinusoidal voltage, but they can also be operated at ATV980 when observing the permitted cable lengths and correct customization.

The Low Harmonic Drive Systems ATV680 and ATV980 offer significant improvement regarding motor load in comparison with older generations with active mains rectifiers AFE (as still offered from many competitors). By the new "3-level" system architecture the voltage load is the same as for ATV660 and ATV960 with classic diode rectifiers and so it not required to take it into account separately.

Basically for all motors from frame size 315 (approximately 110 kW) an insulated bearing on the non-drive end is recommended. It helps to prevent internal current flow inside the motor which can result from unbalances. The insulated bearing is to be understood as supplement to the dv/dt filter choke inside the frequency inverter.

## NOTICE

### OVERVOLTAGE AT THE MOTOR

Do not exceed the maximum length of the motor cables as specified in this document.

**Failure to follow these instructions can result in equipment damage.**

### EMC interferences

The IGBT modules cause high-frequency interferences which drain off more and more strongly to the ground potential with increasing motor cable length. As a result the line-conducted interferences to the mains increase. In case of too long motor cables the attenuation of the mains filters is no longer sufficient and the permitted interference limits are exceeded.

The IGBT modules cause high-frequency interference which increases with increasing motor cable length. If the motor cable length exceeds the maximum cable length, the internal mains filters are no longer sufficient.

#### **⚠ WARNING**

##### **UNEXPECTED EQUIPMENT OPERATION DUE TO HIGH-FREQUENCY INTERFERENCE**

Do not exceed the maximum length of the motor cables as specified in this document.

**Failure to follow these instructions can result in death, serious injury, or equipment damage.**

### Limit values

This product meets the EMC requirements according to the standard IEC 61800-3 if the measures described in this manual are implemented during installation.

If the selected composition (product itself, mains filter, other accessories and measures) does not meet the requirements of category C1, the following information applies as it appears in IEC 61800-3:

#### **⚠ WARNING**

##### **RADIO INTERFERENCE**

In a domestic environment this product may cause radio interference in which case supplementary mitigation measures may be required.

**Failure to follow these instructions can result in death, serious injury, or equipment damage.**

### Bearing currents

The dv/dt filter choke inside the ATV980 frequency inverter effects a significant reduction of the common mode bearing currents.

Especially in case of big motors with middle up to high motor cable lengths the filter chokes are considerable to increase the availability of the motor.

### Multiplication factors

In case of conditions differing from the table the recommended cable lengths have to be converted by means of the following factors.

If several factors apply, please multiply them.

		Correction of the max. cable lengths
The pulse frequency does not correspond to factory setting:	at 4 kHz	multiply all values by 0.70
	at 8 kHz	multiply all values by 0.40
Output frequencies higher than 100 Hz.	up to 200 Hz	multiply all values by 0.80
	up to 300 Hz	multiply all values by 0.50
In case of 6-pole motor cabling (e.g. for star/delta starting circuit)		multiply all values by 0.75
In case of parallel motors with a dedicated cable to each motor the inverter values have to be converted in compliance with the number of motors. When a motor choke is used for each motor, the following values in brackets apply.	at 2 motors	multiply all values by 0.40 (0.80)
	at 3 motors	multiply all values by 0.25 (0.60)
	at 4 motors	multiply all values by 0.15 (0.40)
	at 5 motors	multiply all values by 0.10 (0.25)
In case of parallel motors with a common cable to all motors the inverter values have to be converted in compliance with the number of motors:	at 2 motors	multiply all values by 0.80
	at 3 motors	multiply all values by 0.60
	at 4 motors	multiply all values by 0.40
	at 5 motors	multiply all values by 0.25

### Recommended maximum lengths of motor cables in second environment (industrial environment)

EMC category (EN 61800-3)	ATV980	Chosen option	Type of cable	Max. cable length
C3	C11●4X1...C16●4X1	-	Shielded	50 m
	C11●4X1...C16●4X1	dv/dt filter choke 150m	Shielded	150 m
	C20●4X1...C80●4X1	- (1)	Shielded	150 m
C4	C11●4X1...C16●4X1	-	Unshielded	100 m
	C11●4X1...C16●4X1	dv/dt filter choke 150m	Unshielded	250 m
	C20●4X1...C80●4X1	- (1)	Unshielded	250 m
	C11●4X1...C80●4X1	dv/dt filter choke 300m	Shielded	300 m
	C11●4X1...C80●4X1	dv/dt filter choke 300m	Unshielded	500 m
(1) At ATV980 Drive Systems from 200 kW the dv/dt filter choke 150m is built-in as standard.				

**NOTE:** The specified lengths of motor cables are recommended limits based on typical motor cables, laying in cable channels, default pulse frequency and maximal output frequency of 100 Hz. Longer cable lengths are possible on request.

## Thermal Motor Monitoring

In the Altivar Process Drive System several possibilities for thermal motor monitoring are available:

- Standard sensor inputs AI1, AI3 at the control block Suitable temperature sensors: PTC, Pt100, Pt1000, KTY84
- Sensor inputs AI4, AI5 at expansion card "Logic and analog I/O card" Suitable temperature sensors: PTC, Pt100, Pt1000, KTY84

### **DANGER**

#### **HAZARD OF ELECTRIC SHOCK, EXPLOSION OR ARC FLASH**

- Verify that the temperature sensors in the motor meet the PELV requirements.
- Verify that the motor encoder meets the PELV requirements.
- Verify that any other equipment connected via signal cables meets the PELV requirements.

**Failure to follow these instructions will result in death or serious injury.**

- On customer request the motor monitoring PTC, a PTC thermistor relay (alternatively with ATEX certificate), is installed and the sensor inputs are wired with the option terminals. The evaluation is performed via the diagnostics system in the Altivar Process Drive System.
- On customer request the motor/bearing monitoring Pt100/Pt1000/KTY is installed, which includes evaluation relays and the wiring of the sensor inputs to the option terminals. The evaluation is performed via the diagnostics system in the Altivar Process Drive System.

**NOTE:** When protective separation of the thermistor sensors in the motor cannot be guaranteed or in case of long motor cables, this option is highly recommended.

# Predefined Customizations

Customization / Page	Brief description
<b>Enclosure options</b>	
Increased protection degree IP54, page 128	Enclosure designed in increased protection degree IP54
Enclosure plinth, page 129	Enclosure plinth for basic device in protection degree IP23
Connection enclosure, page 129	Separate connection enclosure; for connection of cables alternatively from top or from bottom.
Enclosure lighting, page 130	Fluorescent lamp and a power socket 230 V AC
Enclosure heating, page 130	Heats the enclosure in order to avoid frost and condensation at an ambient temperature up to -10°C
Modified wiring colors, page 131	Modified wiring colors at the power cables
<b>Control options</b>	
Key switch "local / remote", page 133	Key switch in the enclosure door for switching between remote control and local control
Ethernet port on front door, page 133	Access to the Ethernet network directly on the enclosure door
<b>I/O expansion cards</b>	
Logic and analog I/O card, page 135	Expansion card for additional analog and digital inputs and outputs (6 digital inputs, 2 digital outputs, 2 analog inputs)
Relay output card, page 135	Expansion card with three additional relay outputs
<b>Communication cards</b>	
Communication card CANopen Daisy Chain, page 137	Option card for control of the inverter via CANopen Daisy Chain
Communication card CANopen SUB-D9, page 137	Option card for control of the inverter via CANopen with SUB-D port
Communication card CANopen with screw terminals, page 137	Option card for control of the inverter via CANopen with screw terminals
Communication card DeviceNet, page 137	Option card for control of the inverter via DeviceNet
Communication card Profibus DP, page 137	Option card for control of the inverter via Profibus DP V1
Communication card PROFINET, page 138	Option card for control of the inverter via PROFINET
Communication card EtherCAT Daisy Chain, page 138	Option card for control of the inverter via EtherCAT Daisy Chain
<b>Encoder interfaces</b>	
Digital encoder interface module 5/12 V, page 140	Interface module for connecting a digital encoder
Analog encoder interface module, page 140	Interface module for connecting an analog encoder
Resolver interface module, page 140	Interface module for connecting a resolver
HTL encoder interface module, page 140	Interface module for connecting an encoder with push-pull (HTL) output driver
<b>Functional safety</b>	
STO - SIL 3 Stop category 0, page 142	This option effects a Safe Torque Off at the motor
STO - SIL 3 Stop category 1, page 142	This option effects a Safe Torque Off at the motor with controlled deceleration
<b>Display options</b>	
Front Display Module (FDM), page 144	Measuring device mounted in the enclosure door which indicates the operating data
Indicator lamps on front door, page 144	Three additional Indicator lamps mounted in the enclosure door which indicate the operating state
<b>Motor options</b>	
Motor monitoring PTC, page 146	PTC thermistor relay to monitor the motor temperature via PTC thermistors in the motor
Motor monitoring PTC with ATEX certificate, page 146	PTC thermistor relay to monitor the motor temperature via PTC thermistors in the motor with ATEX certificate

Customization / Page	Brief description
Motor monitoring Pt100/Pt1000/KTY, page 146	Tripping unit to monitor the motor temperature via Pt100/Pt1000/KTY sensors in the motor winding
Bearing monitoring Pt100/Pt1000/KTY, page 147	Tripping unit to monitor the motor temperature via Pt100/Pt1000/KTY sensors in the bearings of the motor
dv/dt filter choke 150 m, page 147	Reduces the slew rate, peak voltage and common mode interferences on the output of the inverter and helps to protect the motor
dv/dt filter choke 300 m, page 147	Helps to protect the motor winding and motor bearings in case of very long motor cable
Motor heating, page 148	Includes a motor circuit breaker, a contactor and the terminals to connect a motor heating
<b>Mains supply</b>	
Circuit breaker, page 150	Mains disconnect unit instead of the main switch, including door handle
Undervoltage coil for circuit breaker 230 V, page 150	When there is no voltage at the undervoltage coil, the circuit breaker switches off
Motor for circuit breaker 230 V, page 151	Remote control of the circuit breaker via control commands is possible by means of this motor drive.
<b>Braking option</b>	
Braking unit option BUO, page 153	The braking unit option is used when a quick shut-down of the drive is required.
Braking resistor BR, page 157	The braking resistor converts the braking energy incurred into heat and thus prevents a further rising of the DC link voltage.
<b>Monitoring</b>	
EcoStruxure Asset Advisor, page 160	EcoStruxure Asset Advisor preventive services is a cloud based monitoring and smart alarming services.
<b>Documentation / Packaging</b>	
Safety labels in local language, page 163	With this option the devices can be ordered with labels in the local language.
Seaworthy packaging, page 163	This option contains a seaworthy packaging for transport by ship.

# Wiring of the Control Terminals

## What's in This Part

Design/Position of the Individual Terminals.....	99
Control Block .....	102
Option "Logic and Analog I/O Card" .....	117
Option "Relay Output Card".....	121
Option Terminals .....	123

# Design/Position of the Individual Terminals

## What's in This Chapter

Overview .....	100
Voltage Supply and Auxiliary Voltage .....	101

## Overview

The Altivar Process Drive Systems are already equipped with extensive terminals on the control block as standard. The use and the function of all inputs and outputs can be parameterized.

In addition, there are the terminals X200 and X205, which are wired internally appropriate to the customizations.

For expansion the option cards Logic and analog I/O card and the relay output card are available. Both expansion cards can be installed, but the same card cannot be plugged twice.

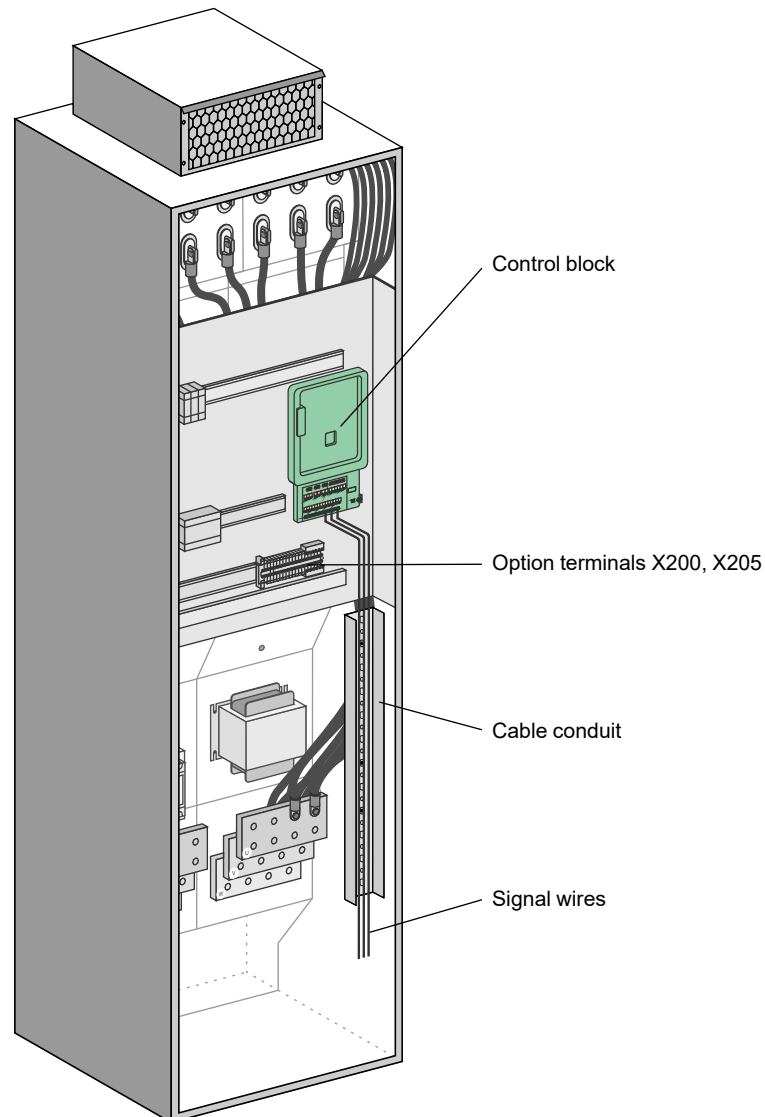

## Voltage Supply and Auxiliary Voltage

All Drive Systems are equipped with a control transformer matching with the mains voltage and the required power. It provides a 230 Vac control voltage for supplying the fans in the enclosure doors and the DC supply units. The DC supply units generate 48 Vdc for the internal power part fans and a 24 Vdc auxiliary voltage. All control components are supplied by the internally provided voltages.

**NOTE:** For buffering the control block and with that keeping communication alive (e.g. fieldbus), the control block can be supplied via the terminals P24 and 0V externally with 24 Vdc.

### **DANGER**

#### **ELECTRIC SHOCK CAUSED BY INCORRECT POWER SUPPLY UNIT**

The +24VDC supply voltage is connected with many exposed signal connections in the device.

- Use a power supply unit that meets the PELV (Protective Extra Low Voltage) requirements.

**Failure to follow these instructions will result in death or serious injury.**

# Control Block

## What's in This Chapter

Structure of the Control Block .....	103
Control Terminals at the Control Block.....	104
Specification of the Control Terminals .....	105
Relay Contacts Wiring .....	109
Digital Inputs Wiring Depending on Sink / Source Switch Configuration .....	112
Pulse Train Output / Digital Output Switch Configuration.....	114

## Structure of the Control Block

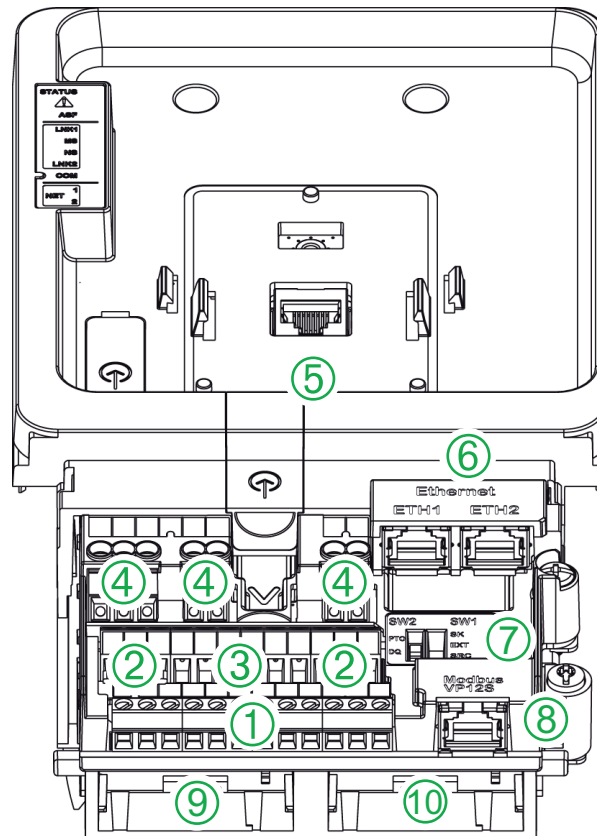

- 1 Control terminals of digital inputs
- 2 Control terminals STO (Safe Torque Off) and analog outputs
- 3 Control terminals of analog inputs
- 4 Control terminals of relay outputs
- 5 RJ45 port for the graphical keypad
- 6 Dual port RJ45 for Ethernet IP or Modbus TCP
- 7 Sink-Ext-Source selector switch and PTO/DQ selector switch
- 8 RJ45 port for serial Modbus
- 9 Slot B for I/O expansion card or encoder interface module
- 10 Slot A for communication card or I/O expansion card

# Control Terminals at the Control Block

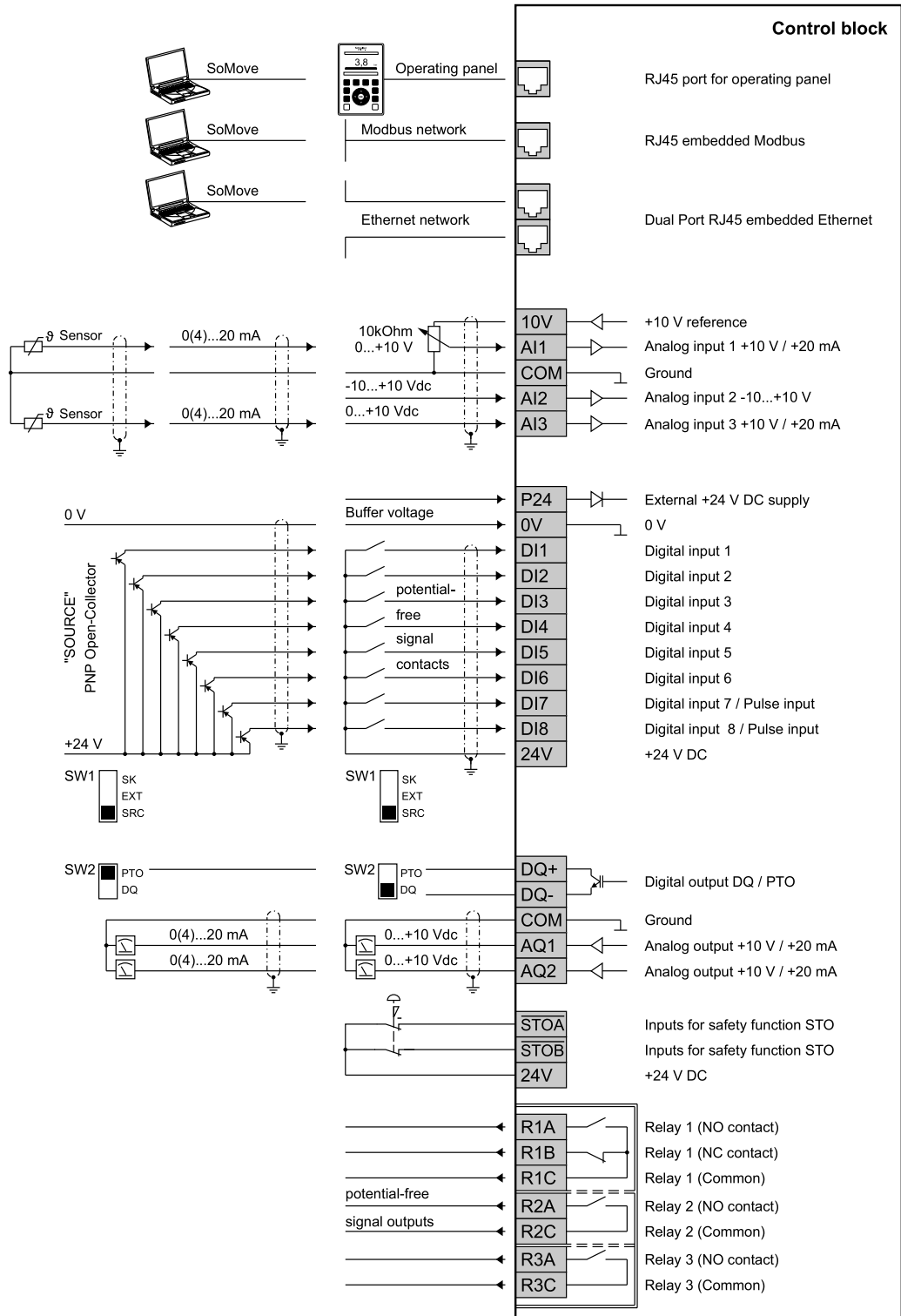

## Specification of the Control Terminals

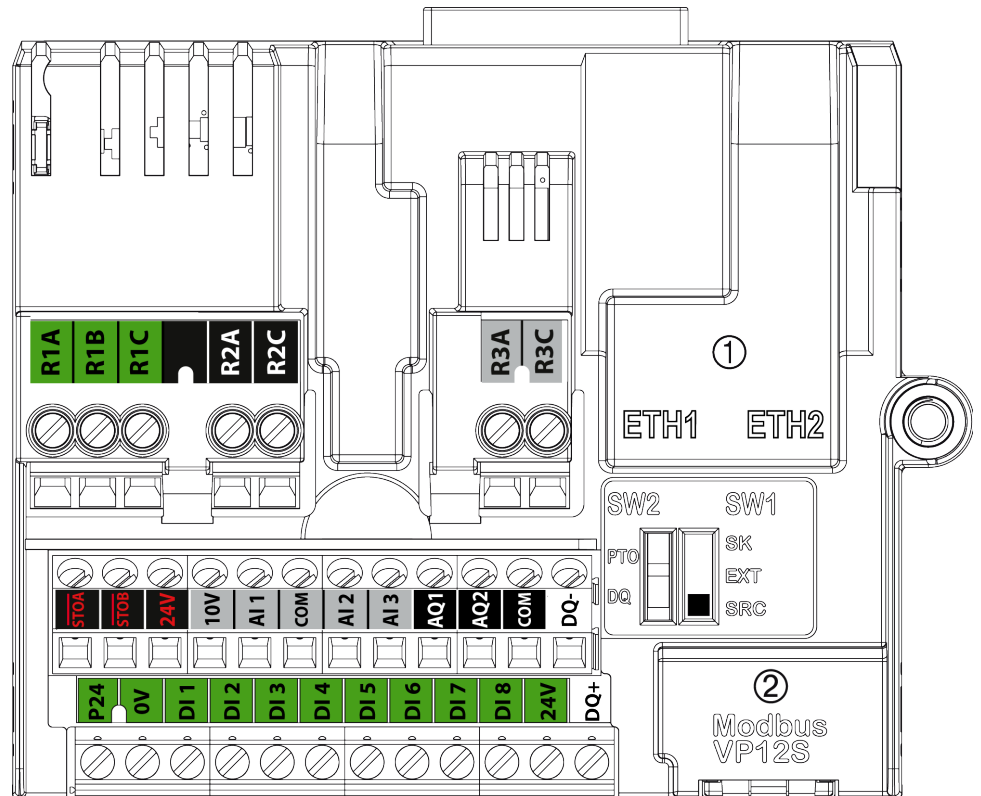

### Screw terminals

Maximum cable cross section for all terminals:

- 1.5 mm<sup>2</sup> (AWG 16), 0.25 Nm (2.2 lbf.in)

Minimum cable cross section:

- For relay terminals 0.75 mm<sup>2</sup> (AWG 18)
- For all other terminals 0.5 mm<sup>2</sup> (AWG 20)

Strip length: 10 mm (0.39 in.)

Maximum cable length:

- AI●, AO●, DI●, DQ●: 50 m (164 ft) shielded
- $\overline{\text{STOA}}$ ,  $\overline{\text{STOB}}$ : 30 m (98 ft) unshielded

Terminal	Description	I/O Type	Electrical characteristics
R1A	NO contact of relay R1	O	<b>Output Relay 1</b> <ul style="list-style-type: none"> <li>Minimum switching capacity: 5 mA for 24 Vdc</li> <li>Maximum switching current on resistive load: 3 A for 250 Vac (OVC II) and 30 Vdc</li> <li>Maximum switching current on inductive load (<math>\cos \phi \geq 0.4</math> and <math>L/R \leq 7</math> ms): 2 A for 250 Vac (OVC II) and 30 Vdc. Inductive load must be equipped with a voltage surge limitation device according to AC or DC operation with total energy dissipation greater than the inductive energy stored in the load. Refer to sections Output Relay with Inductive AC Loads , page 109 and Output Relay with Inductive DC Loads , page 110.</li> <li>Refresh time: 1 ms <math>\pm</math> 0.25 ms</li> <li>Service life: 100,000 operations at maximum switching current</li> </ul>
R1B	NC contact of relay R1	O	
R1C	Common point contact of relay R1	O	
R2A	NO contact of relay R2	O	<b>Output Relay 2</b> <ul style="list-style-type: none"> <li>Minimum switching capacity: 5 mA for 24 Vdc</li> <li>Maximum switching current on resistive load: 5 A for 250 Vac (OVC II) and 3A for 30 Vdc</li> <li>Maximum switching current on inductive load (<math>\cos \phi \geq 0.4</math> and <math>L/R \leq 7</math> ms): 2 A for 250 Vac (OVC II) and 30 Vdc. Inductive load must be equipped with a voltage surge limitation device according to AC or DC operation with total energy dissipation greater than the inductive energy stored in the load. Refer to sections Output Relay with Inductive AC Loads , page 109 and Output Relay with Inductive DC Loads , page 110.</li> <li>Refresh time: 1 ms <math>\pm</math> 0.25 ms</li> <li>Service life:                             <ul style="list-style-type: none"> <li>100,000 operations at maximum switching current</li> <li>1,000,000 operations at 0.5 A</li> </ul> </li> </ul>
R2C	Common point contact of relay R2	O	
R3A	NO contact of relay R3	O	<b>Output Relay 3</b> <ul style="list-style-type: none"> <li>Minimum switching capacity: 5 mA for 24 Vdc</li> <li>Maximum switching current on resistive load: 5 A for 250 Vac (OVC II) and 3 A for 30 Vdc</li> <li>Maximum switching current on inductive load (<math>\cos \phi \geq 0.4</math> and <math>L/R \leq 7</math> ms): 2 A for 250 Vac (OVC II) and 30 Vdc. Inductive load must be equipped with a voltage surge limitation device according to AC or DC operation with total energy dissipation greater than the inductive energy stored in the load. Refer to sections Output Relay with Inductive AC Loads , page 109 and Output Relay with Inductive DC Loads , page 110.</li> <li>Refresh time: 1 ms <math>\pm</math> 0.25 ms</li> <li>Service life:                             <ul style="list-style-type: none"> <li>100,000 operations at maximum switching current</li> <li>1,000,000 operations at 0.5 A</li> </ul> </li> </ul>
R3C	Common point contact of relay R3	O	
$\overline{\text{STOA}}$ , $\overline{\text{STOB}}$	STO inputs	I	<b>Safety Function STO Inputs</b> Refer to the ATV900 Embedded Safety Function manual NHA80947 available on <a href="http://www.schneider-electric.com">www.schneider-electric.com</a>
24V	Output power supply for digital inputs and safety function STO inputs	O	Use only PELV standard power supply unit. <ul style="list-style-type: none"> <li>+24 Vdc</li> <li>Tolerance: minimum 20.4 Vdc, maximum 27 Vdc</li> <li>Current: maximum 200 mA for both 24 Vdc terminals</li> <li>Terminal protected against overload and short-circuit</li> <li>In Sink Ext position, this supply is powered by external PLC supply</li> </ul>
10V	Output supply for Analog input	O	Internal supply for the analog inputs <ul style="list-style-type: none"> <li>10.5 Vdc</li> <li>Tolerance <math>\pm 5</math> %</li> <li>Current: maximum 10 mA</li> <li>Short circuit protected</li> </ul>

Terminal	Description	I/O Type	Electrical characteristics
AI1, AI3	Analog inputs and sensor inputs	I	<p>Software-configurable V/A : voltage or current analog input</p> <ul style="list-style-type: none"> <li>Voltage analog input 0...10 Vdc, impedance 31.5 k<math>\Omega</math>,</li> <li>Current analog input X-Y mA by programming X and Y from 0...20 mA, with impedance 250 <math>\Omega</math></li> <li>Sampling time: 1 ms + 1 ms maximum</li> <li>Resolution 12 bits</li> <li>Accuracy: <math>\pm 0.6</math> % for a temperature variation of 60 °C (140 °F)</li> <li>Linearity <math>\pm 0.15</math> % of maximum value</li> </ul> <p>Software-configurable thermal sensors or Water level sensor</p> <ul style="list-style-type: none"> <li><b>PT100</b> <ul style="list-style-type: none"> <li>1 thermal sensor</li> <li>Thermal sensor current: 5 mA maximum</li> <li>Range -20...200 °C (-4...392 °F)</li> <li>Accuracy <math>\pm 4</math> °C (7.2 °F) for a temperature variation of 60 °C (140 °F)</li> </ul> </li> <li><b>PT1000</b> <ul style="list-style-type: none"> <li>1 thermal sensor</li> <li>Thermal sensor current: 1 mA</li> <li>Range -20...200 °C (-4...392 °F)</li> <li>Accuracy <math>\pm 4</math> °C (7.2 °F) for a temperature variation of 60 °C (140 °F)</li> </ul> </li> <li><b>KTY84</b> <ul style="list-style-type: none"> <li>1 thermal sensor</li> <li>Thermal sensor current: 1 mA</li> <li>Range -20...200 °C (-4...392 °F)</li> <li>Accuracy <math>\pm 4</math> °C (7.2 °F) for a temperature variation of 60 °C (140 °F)</li> </ul> </li> <li><b>PTC</b> <ul style="list-style-type: none"> <li>1 thermal sensor or 3 thermal sensors or 6 thermal sensors mounted in series</li> <li>Thermal sensor current: 1 mA</li> <li>Nominal value: &lt; 1.5 k<math>\Omega</math></li> <li>Overheat trigger threshold: 2.9 k<math>\Omega</math> <math>\pm</math> 0.2 k<math>\Omega</math></li> <li>Overheat reset threshold: 1.575 k<math>\Omega</math> <math>\pm</math> 75 <math>\Omega</math></li> <li>Low impedance detection threshold : 50 <math>\Omega</math> -10 <math>\Omega</math> / +20 <math>\Omega</math></li> <li>Open circuit threshold : 100 k<math>\Omega</math> <math>\pm</math> 10k<math>\Omega</math></li> </ul> </li> </ul>
COM	Analog I/O common	I/O	0 V for Analog outputs
AI2	Analog input	I	<p>Voltage bipolar analog input -10...10 Vdc, impedance 31.5 k<math>\Omega</math></p> <ul style="list-style-type: none"> <li>Sampling time: 1 ms + 1 ms maximum</li> <li>Resolution 12 bits</li> <li>Accuracy: <math>\pm 0.6</math> % for a temperature variation of 60 °C (108 °F)</li> <li>Linearity <math>\pm 0.15</math> % of maximum value</li> </ul>
AQ1	Analog output	O	<p>AQ: Analog output software-configurable for voltage or current</p> <ul style="list-style-type: none"> <li>Voltage analog output 0...10 Vdc, minimum. Minimum load impedance 470 <math>\Omega</math>,</li> <li>Current analog output X-Y mA by programming X and Y from 0...20 mA, maximum load impedance 500 <math>\Omega</math></li> <li>Sampling time: 5 ms + 1 ms maximum</li> <li>Resolution 10 bits</li> <li>Accuracy: <math>\pm 1</math> % for a temperature variation of 60 °C (108 °F)</li> <li>Linearity <math>\pm 0.2</math> %</li> </ul>
AQ2	Analog output	O	
COM	Digital and analog output Common	I/O	0 V for analog outputs and logic output
DQ-	Digital output	O	<p>Digital output configurable by switch</p> <ul style="list-style-type: none"> <li>Insulated</li> <li>Maximum voltage: 30 Vdc</li> <li>Maximum current: 100 mA</li> <li>Frequency range: 0...1 kHz</li> <li>Positive/Negative logic is managed by user external wiring.</li> </ul>
DQ+	Digital output	O	

Terminal	Description	I/O Type	Electrical characteristics
DQ+	Pulse output	O	Pulse train output configurable by switch <ul style="list-style-type: none"> <li>• Open collector not insulated</li> <li>• Maximum voltage: 30 Vdc</li> <li>• Maximum current: 20 mA</li> <li>• Frequency range: 0...30 kHz</li> </ul>
P24	External input supply	I	+24 Vdc external input supply <ul style="list-style-type: none"> <li>• Tolerance: minimum 19 Vdc, maximum 30 Vdc</li> <li>• Maximum current: 0.8 A</li> </ul>
0V	0 V	I/O	0 V of P24
DI1-DI8	Digital inputs	I	8 programmable logic inputs 24 Vdc, comply with IEC/EN 61131-2 logic type 1 <ul style="list-style-type: none"> <li>• Positive logic (Source): State 0 if <math>\leq 5</math> Vdc or logic input not wired, state 1 if <math>\geq 11</math> Vdc</li> <li>• Negative logic (Sink): State 0 if <math>\geq 16</math> Vdc or logic input not wired, state 1 if <math>\leq 10</math> Vdc</li> <li>• Impedance 3.5 k<math>\Omega</math></li> <li>• Maximum voltage: 30 Vdc</li> <li>• Sampling time: 2 ms + 0.5 ms maximum</li> </ul> Multiple assignment makes it possible to configure several functions on one input (example: DI1 assigned to forward and preset speed 2, DI3 assigned to reverse and preset speed 3).
DI7-DI8	Pulse inputs	I	Programmable Pulse input <ul style="list-style-type: none"> <li>• Comply with level 1 PLC, IEC 65A-68 standard</li> <li>• State 0 if <math>&lt; 0.6</math> Vdc, state 1 if <math>&gt; 2.5</math> Vdc</li> <li>• Pulse counter 0...30 kHz</li> <li>• Frequency range: 0...30 kHz</li> <li>• Cyclic ratio: 50 % <math>\pm</math> 10 %</li> <li>• Maximum input voltage 30 Vdc, <math>&lt; 10</math> mA</li> <li>• Sampling time: 5 ms + 1 ms maximum</li> </ul>

**⚡ ⚠ DANGER**

**HAZARD OF ELECTRIC SHOCK, EXPLOSION OR ARC FLASH**

- Verify that the temperature sensors in the motor meet the PELV requirements.
- Verify that the motor encoder meets the PELV requirements.
- Verify that any other equipment connected via signal cables meets the PELV requirements.

**Failure to follow these instructions will result in death or serious injury.**

Signal interference can cause unexpected responses of the device and of other equipment in the vicinity of the device.

**⚠ WARNING**

**SIGNAL AND EQUIPMENT INTERFERENCE**

- Install the wiring in accordance with the EMC requirements described in this document.
- Verify compliance with the EMC requirements described in this document.
- Verify compliance with all EMC regulations and requirements applicable in the country in which the product is to be operated and with all EMC regulations and requirements applicable at the installation site.

**Failure to follow these instructions can result in death, serious injury, or equipment damage.**

# Relay Contacts Wiring

## Output Relay with Inductive AC Loads

### General

The AC voltage source must be of overvoltage category II (OVC II) according to IEC 61800-5-1.

If it is not the case, an isolation transformer must be used.

### Contactors with AC Coil

If controlled by a relay, a resistor-capacitor (RC) circuit must be connected in parallel to the coil of the contactor as shown on the diagram below:

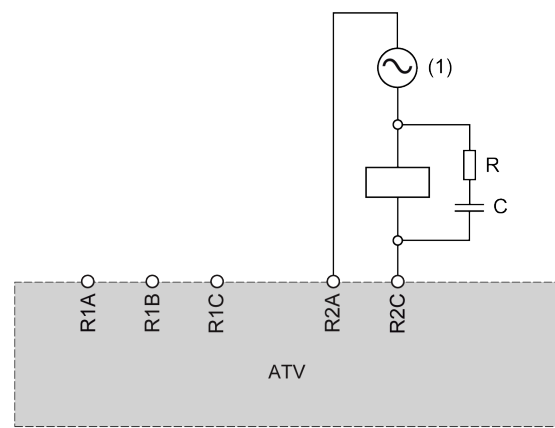

(1) AC 250 Vac maximum.

Schneider Electric AC contactors have a dedicated area on the housing to plug easily the RC device. Refer to the Motor control and protection components catalog MKTED210011EN available on [se.com](http://se.com) to find the RC device to be associated with the contactor used.

**Example:** With a 48 Vac source, contactors LC1D09E7 or LC1DT20E7 have to be used with LAD4RCE voltage suppression device.

### Other Inductive AC Loads

For other inductive AC loads:

- Use an auxiliary contactor connected on the product to control the load.
 

**Example:** with a 48 Vac source, auxiliary contactors CAD32E7 or CAD50E7 with LAD4RCE voltage suppression device.
- When using a third party inductive AC load, request the supplier to provide information on the voltage suppression device, in order to avoid overvoltage above 375 V during relay opening.

## Output Relay with Inductive DC loads

### Contactors with DC Coil

If controlled by a relay, a bidirectional transient voltage suppression (TVS) diode, also called transil, must be connected in parallel to the coil of the contactor as shown on the diagram below:

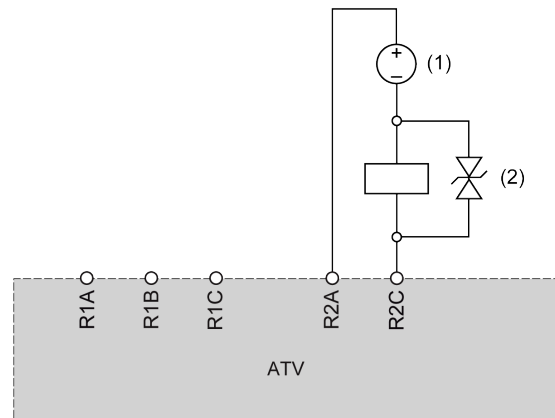

**(1)** DC 30 Vdc maximum.

**(2)** TVS diode

Schneider Electric contactors with DC coil include the TVS diode. No additional device is required.

Refer to the Motor control and protection components catalog MKTED210011EN available on [se.com](http://se.com) for more information.

## Other Inductive DC Loads

Other inductive DC loads without embedded TVS diode must use one of the following voltage suppression device:

- A bidirectional TVS device as shown on the diagram above, defined by:
  - TVS break-down voltage greater than 35 Vdc,
  - TVS clamping voltage V(TVS) less than 50 Vdc
  - TVS peak power dissipation greater than load rated current,  $I(\text{load}) \times V(\text{TVS})$ .

**Example:** with  $I(\text{load}) = 0.9 \text{ A}$  and  $V(\text{TVS}) = 50 \text{ Vdc}$ , TVS peak power must be greater than 45 W

- TVS average power dissipation greater than the value calculated by the following  $0.5 \times I(\text{load}) \times V(\text{TVS}) \times \text{load time constant} \times \text{number of operation per second}$ .

**Example:** with  $I(\text{load}) = 0.9 \text{ A}$  and  $V(\text{TVS}) = 50 \text{ Vdc}$ , load time constant = 40 ms (load inductance divided by load resistance) and 1 operation every 3 s, the TVS average power dissipation must be greater than  $0.5 \times 0.9 \times 50 \times 0.04 \times 0.33 = 0.3 \text{ W}$ .

- A fly-back diode as shown in the diagram below:

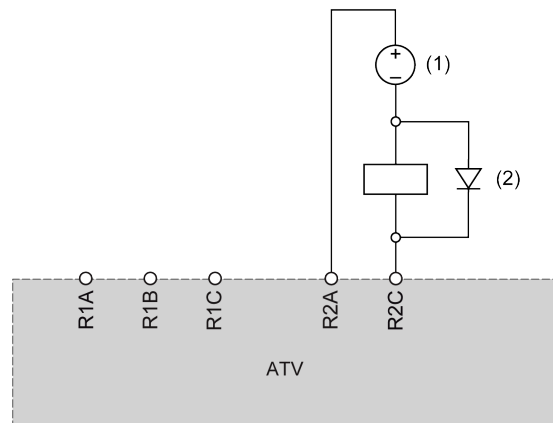

(1) DC 30 Vdc maxi.

(2) Flyback diode

The diode is a polarized device. The fly-back diode must be defined by:

- a reverse voltage greater than 100 Vdc,
- a rated current greater than two times the load rated current,
- a thermal resistance: junction to ambient temperature (in K/W) less than  $90 / (1.1 \times I(\text{load}))$  to operate at maximum 60°C (140°F) ambient temperature.

**Example:** with  $I(\text{load}) = 1.5 \text{ A}$ , select a 100 V, 3 A rated current diode with a thermal resistance from junction to ambient less than  $90 / (1.1 \times 1.5) = 54.5 \text{ K/W}$ .

Using a flyback diode, the relay opening time will be longer than with a TVS diode.

**NOTE:** Use diodes with leads for easy wiring and keep at least 1 cm (0.39 in.) of leads on each side of the case of the diode for a correct cooling.

# Digital Inputs Wiring Depending on Sink / Source Switch Configuration

## About the Switch

**⚠ WARNING**

**UNANTICIPATED EQUIPMENT OPERATION**

- If the device is set to **SK** or **EXT**, do not connect the **0 V** terminal to ground or to protective ground.
- Verify that accidental grounding of digital inputs configured for sink logic, caused, for example, by damage to the signal cables, cannot occur.
- Follow all applicable standards and directives such as NFPA 79 and EN 60204 for proper control circuit grounding practices.

**Failure to follow these instructions can result in death, serious injury, or equipment damage.**

The switch is used to adapt the operation of the logic inputs to the technology of the programmable controller outputs. To access the switch, follow the Access to control Terminals procedure of the ATV900 Installation manual.

The switch is located on the right hand side of the control terminals at the control block, page 103.

- Set the switch to Source (factory setting) if using PLC outputs with PNP transistors.
- Set the switch to Ext if using PLC outputs with NPN transistors.

## Wiring With Use of the Output Power Supply for the Digital Inputs

Switch set to **SRC** (Source) position

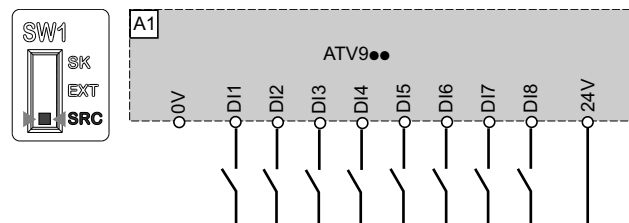

Switch set to **SK** (Sink) position

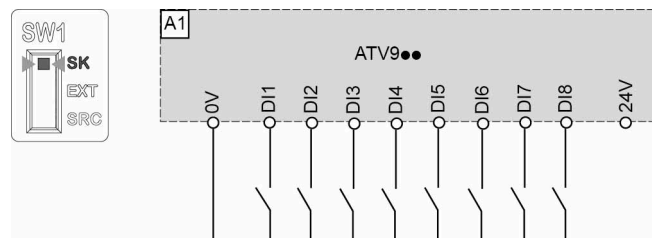

# Wiring With Use of an External Power Supply for the Digital Inputs

## ⚠ ⚠ DANGER

### ELECTRIC SHOCK CAUSED BY INCORRECT POWER SUPPLY UNIT

The +24VDC supply voltage is connected with many exposed signal connections in the device.

- Use a power supply unit that meets the PELV (Protective Extra Low Voltage) requirements.

**Failure to follow these instructions will result in death or serious injury.**

## NOTICE

### INCORRECT VOLTAGE

Supply the digital inputs with 24 Vdc only.

**Failure to follow these instructions can result in equipment damage.**

Switch set to **EXT** (Sink External) position **without functional isolation** on digital inputs

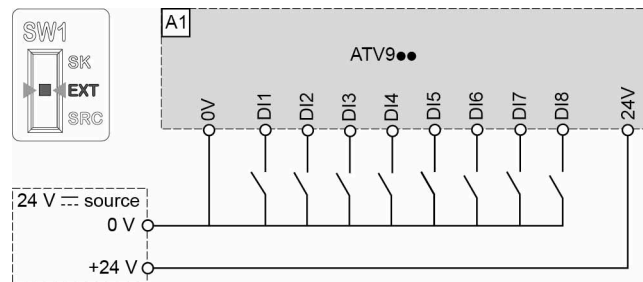

Switch set to **EXT** (Sink External) position **with functional isolation** on digital inputs. This configuration requires the use of 2 external supply units.

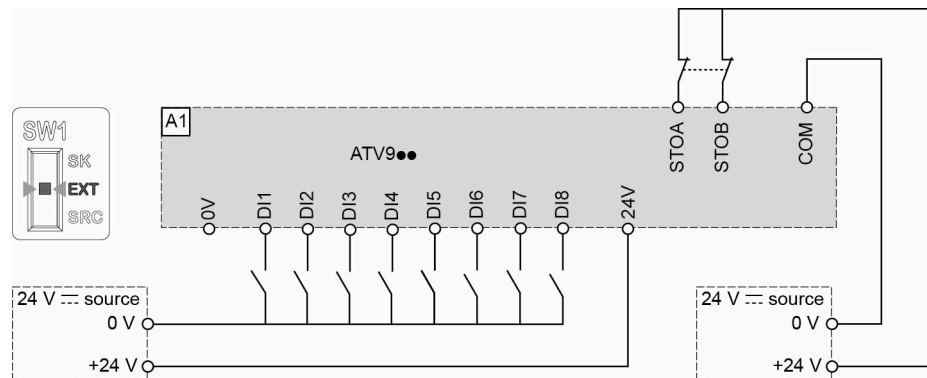

**NOTE:**

- STO inputs are also connected by default on a 24 Vdc terminal. If the external power supply is switched off, the function STO will be triggered.
- To avoid to trigger the STO function when switching-on the product, the external power supply must be previously switched on.

Switch set to **SRC** (Source) position

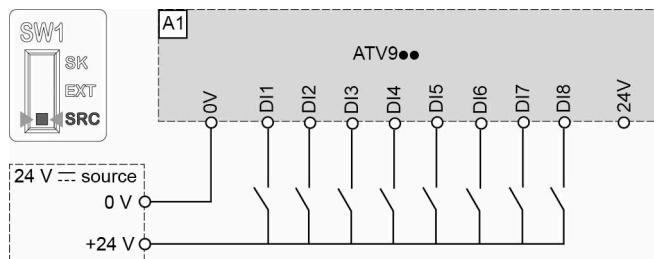

## Pulse Train Output / Digital Output Switch Configuration

### Purpose

**⚠ WARNING**

**UNANTICIPATED EQUIPMENT OPERATION**

- If the device is set to **SK** or **EXT**, do not connect the **0 V** terminal to ground or to protective ground.
- Verify that accidental grounding of digital inputs configured for sink logic, caused, for example, by damage to the signal cables, cannot occur.
- Follow all applicable standards and directives such as NFPA 79 and EN 60204 for proper control circuit grounding practices.

**Failure to follow these instructions can result in death, serious injury, or equipment damage.**

The SW2 (PTO/DQ) switch is used to configure the DQ+ or DQ- digital outputs.

- Set the switch to **PTO (Pulse Train Output)** to configure DQ+ and DQ- outputs as pulse train outputs. This may be used to chain pulse train inputs of another drive, using its DI7 or DI8 pulse inputs.
- Set the switch to **DQ (Digital Output)** to configure DQ+ and DQ- outputs as an assignable logic output.

### Access

To access the switch, follow the Access to control Terminals procedure of the ATV900 Installation manual.

The switch is located on the right hand side of the control terminals at the control block, page 103.

## PTO, Pulse Train Output Configuration

### Switches SW1 (A1&A2) Set to SK (Sink mode) Position

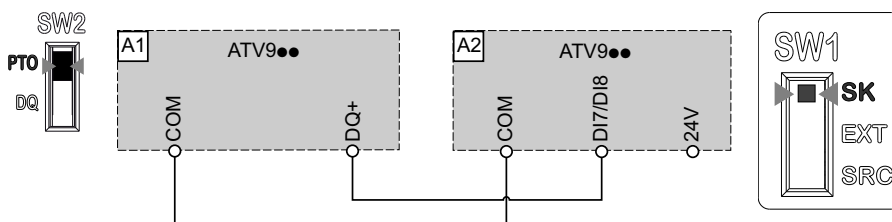

### Switches SW1 (A1&A2) Set to EXT (Sink ext mode) Position

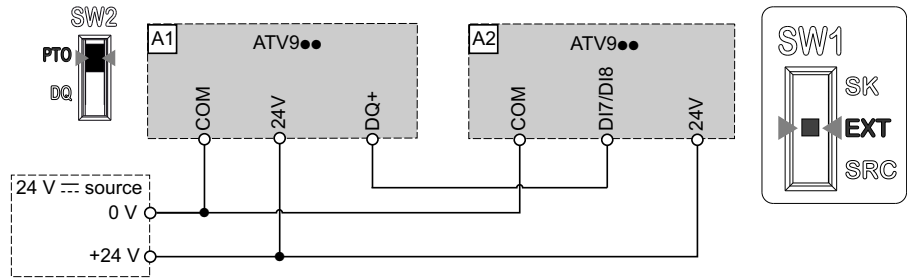

### Switches SW1 (A1&A2) Set to SRC (Source mode) Position

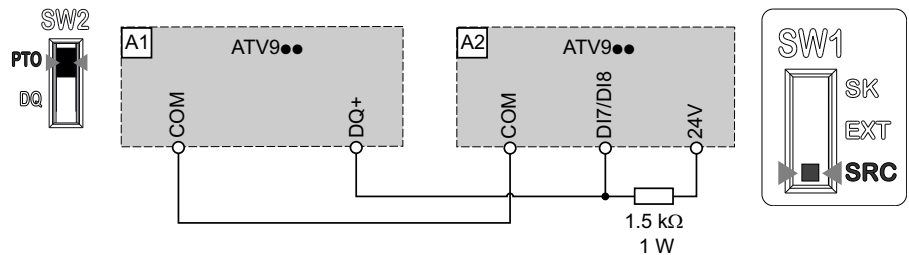

### Switches SW1 (A1&A2) Set to SRC (Source ext mode) Position

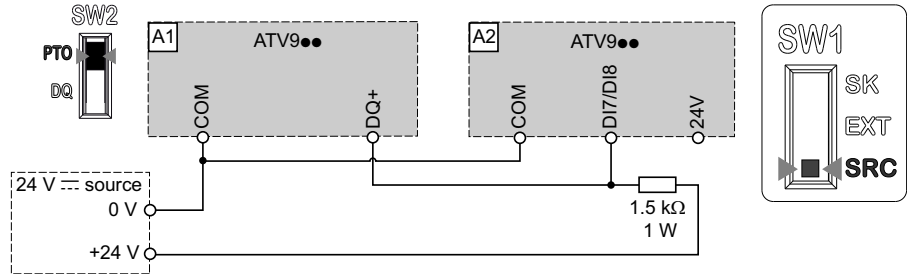

### DQ, Digital Output Configuration

#### Switch SW1 Set to SK (Sink mode) Position

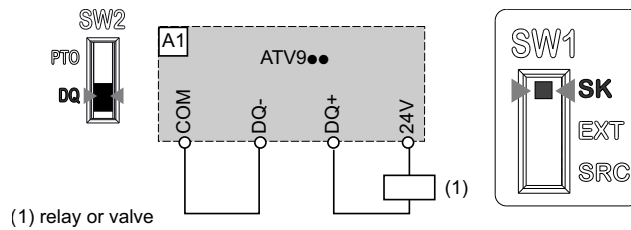

### Switch SW1 Set to EXT (Sink ext mode) Position

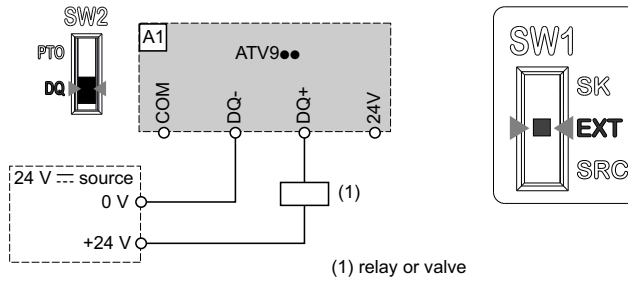

### Switch SW1 Set to SRC (Source mode) Position

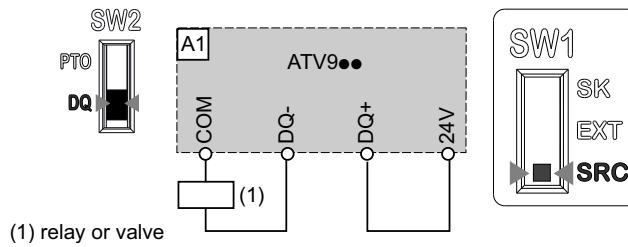

### Switch SW1 Set to SRC (Source ext mode) Position

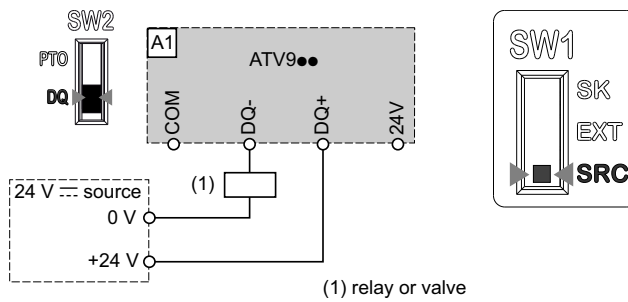

# Option "Logic and Analog I/O Card"

## What's in This Chapter

Control terminals at the expansion card .....	118
Specification of the Control Terminals .....	119

# Control terminals at the expansion card

Option to expand the control inputs and control outputs of the control block. The expansion card contains two analog inputs, six digital inputs and two digital outputs.

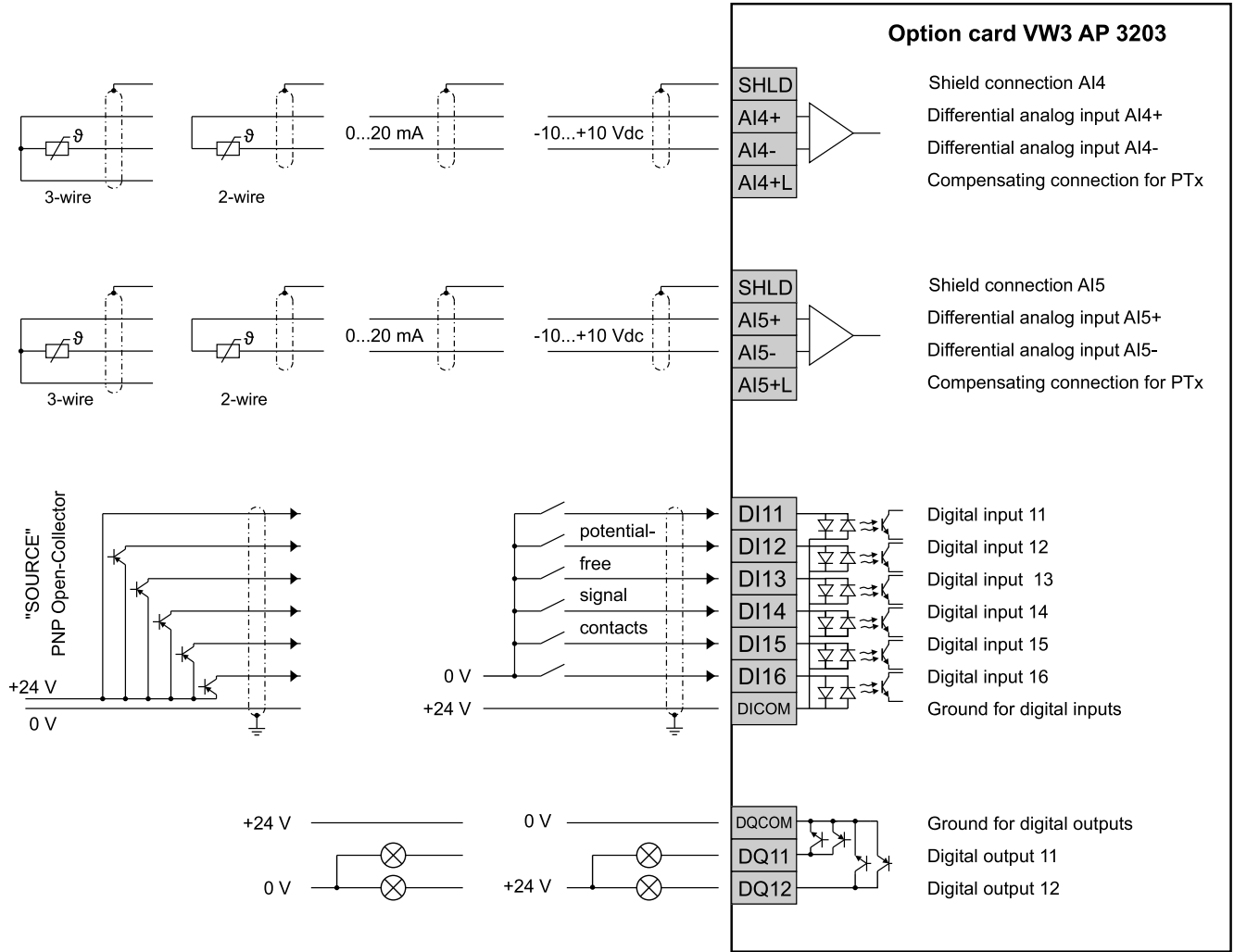

# Specification of the Control Terminals

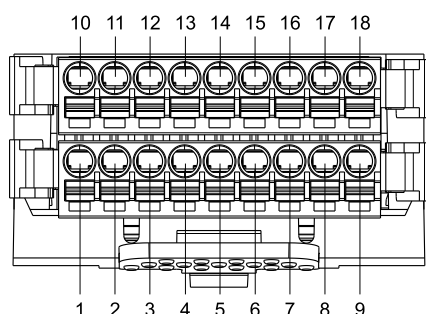

**Spring terminals**

Max. cable cross section: 1 mm<sup>2</sup> (AWG 16)

Strip length: 10 mm

Max. cable length AI●, AQ●, DI●, DQ●: 50 m (164 ft) shielded

Pin	Terminal	Description	Specification
1	SHLD	Shield connection for AI4	You can select between voltage, current, Pt100, Pt1000, KTY84 and PTC measurement by software configuration.  <b>Differential voltage at the input circuit:</b> <ul style="list-style-type: none"> <li>• Range: -10 V DC...+10 V DC</li> <li>• Impedance: 20 kΩ</li> <li>• Resolution: 11 bits + 1 sign bit</li> <li>• Accuracy: ±0.6 % for a temperature variation of 60 °C</li> <li>• Linearity ±0.15 % of maximum value</li> </ul> <b>Current measurements:</b> <ul style="list-style-type: none"> <li>• Range: freely programmable from 0...20 mA</li> <li>• Impedance: 250 Ω</li> <li>• Resolution: 12 bits</li> <li>• Accuracy: ±0.6 % for a temperature variation of 60 °C</li> <li>• Linearity ±0.15 % of maximum value</li> <li>• Sampling period: 1 ms</li> </ul> <b>PTx measurement:</b> Pt100, Pt1000, PTC or KTY84 configurable by software <ul style="list-style-type: none"> <li>• <b>Pt100</b> <ul style="list-style-type: none"> <li>◦ 1 or 3 temperature sensors in series per analog input (configurable by software)</li> <li>◦ Temperature sensor current: max. 7.5 mA</li> <li>◦ Range -20...200 °C</li> <li>◦ Accuracy: ±3°C for a temperature variation of 60 °C</li> </ul> </li> <li>• <b>Pt1000, KTY84</b> <ul style="list-style-type: none"> <li>◦ 1 (Pt1000, KTY84) or 3 (Pt1000) temperature sensors in series per analog input (configurable by software)</li> <li>◦ Temperature sensor current: max. 1 mA</li> <li>◦ Range -20...200 °C</li> <li>◦ Accuracy: ±3 °C for a temperature variation of 60 °C</li> </ul> </li> <li>• <b>PTC</b> <ul style="list-style-type: none"> <li>◦ 3 or 6 temperature sensors in series</li> <li>◦ Temperature sensor current: max. 1 mA</li> <li>◦ Nominal value: &lt; 1.5 kΩ</li> <li>◦ Overheat trigger threshold: 3 kΩ</li> <li>◦ Overheat reset threshold: 1.8 kΩ</li> <li>◦ Short-circuit detection threshold &lt; 50 Ω</li> <li>◦ Wire break detection: &gt; 100 kΩ</li> </ul> </li> </ul>
2	AI4+	<b>Differential analog input 4</b>  Depending on software configuration: <ul style="list-style-type: none"> <li>• Measurement of differential voltage</li> <li>• PTx measurement</li> <li>• 0...20 mA measurement</li> <li>• Reference potential AI4- for AI4+</li> </ul>	
3	AI4-		
4	AI4+L	Compensating connection for one temperature sensor Pt100, Pt1000 or KTY84 in 3-wire-design	
5	SHLD	Shield connection for AI5	
6	AI5+	<b>Differential analog input 5</b>  Depending on software configuration: <ul style="list-style-type: none"> <li>• Measurement of differential voltage</li> <li>• PTx measurement</li> <li>• 0...20 mA measurement</li> <li>• Reference potential AI5- for AI5+</li> </ul>	
7	AI5-		
8	AI5+L	Compensating connection for one temperature sensor Pt100, Pt1000 or KTY84 in 3-wire-design	
9	DQ12	Digital output 12	

Pin	Terminal	Description	Specification
10	DICOM	Reference potential for the digital inputs	The 24 V DC digital inputs DI are galvanically isolated via optocoupler and comply with the standard IEC/EN 61131-2. <ul style="list-style-type: none"> <li>• Logic type selected by DICOM wiring</li> <li>• Positive logic (Source): state 0 when <math>\leq 5</math> V DC, state 1 when <math>\geq 11</math> V DC</li> <li>• Negative logic (Sink): state 0 when <math>\geq 16</math> V DC, state 1 when <math>\leq 10</math> V DC</li> <li>• Maximum voltage: <math>\leq 30</math> V DC</li> <li>• Input current (typically): 2.5 mA</li> <li>• Sampling period: 1 ms</li> </ul>
11	DI11	Digital input 11	
12	DI12	Digital input 12	
13	DI13	Digital input 13	
14	DI14	Digital input 14	
15	DI15	Digital input 15	
16	DI16	Digital input 16	
17	DQCOM	Reference potential for the digital outputs	The 24 V DC digital outputs DQ comply with the standard IEC/EN 61131-2. <ul style="list-style-type: none"> <li>• Logic type selected by DQCOM wiring</li> <li>• Output voltage: <math>\leq 30</math> V DC</li> <li>• Switching capability: <math>\leq 100</math> mA</li> <li>• Voltage drop at 100 mA load: <math>\leq 3</math> V DC</li> <li>• Response time: 1 ms</li> </ul>
18	DQ11	Digital output 11	

**⚠️ DANGER**

**HAZARD OF ELECTRIC SHOCK, EXPLOSION OR ARC FLASH**

- Verify that the temperature sensors in the motor meet the PELV requirements.
- Verify that the motor encoder meets the PELV requirements.
- Verify that any other equipment connected via signal cables meets the PELV requirements.

**Failure to follow these instructions will result in death or serious injury.**

Signal interference can cause unexpected responses of the device and of other equipment in the vicinity of the device.

**⚠️ WARNING**

**SIGNAL AND EQUIPMENT INTERFERENCE**

- Install the wiring in accordance with the EMC requirements described in this document.
- Verify compliance with the EMC requirements described in this document.
- Verify compliance with all EMC regulations and requirements applicable in the country in which the product is to be operated and with all EMC regulations and requirements applicable at the installation site.

**Failure to follow these instructions can result in death, serious injury, or equipment damage.**

# Option "Relay Output Card"

## What's in This Chapter

Control terminals at the expansion card .....	122
Specification of the Control Terminals of the "Relay Output Card" .....	122

## Control terminals at the expansion card

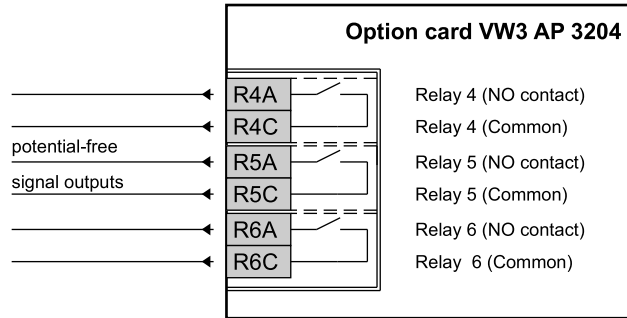

## Specification of the Control Terminals of the "Relay Output Card"

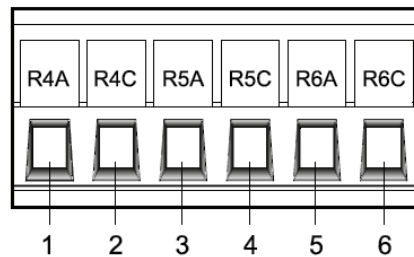

**Spring terminals**

Max. cable cross section: 1.5 mm<sup>2</sup> (AWG 16)

Maximum tightening torque: 0.5 Nm (4.4 lb.in)

Minimum cable cross section: 0.75 mm<sup>2</sup> (AWG 18)

Strip length: 10 mm

Pin	Terminal	Description	Specification
1	R4A	N. O. contact	<b>Programmable relay outputs R4, R5 and R6:</b> <ul style="list-style-type: none"> <li>Minimum switching capacity: 5 mA for 24 Vdc</li> <li>Maximum switching capacity on resistive load: 5 A for 250 Vac (OVC II) and 30 Vdc</li> <li>Maximum switching capacity on inductive load: 2 A for 250 Vac (OVC II) and 30 Vdc Inductive load must be equipped with a voltage surge suppression device according to AC or DC operation with total energy dissipation greater than the inductive energy stored in the load. Refer to sections Output Relay with Inductive AC Loads, page 109 and Output Relay with Inductive DC loads, page 110.</li> <li>Refresh time according to the relay output of the drive in which the relay output card is installed.</li> <li>Service life:                             <ul style="list-style-type: none"> <li>70,000 switching cycles at 5 A and resistive load</li> <li>100,000 switching cycles at 4 A and resistive load</li> <li>300,000 switching cycles at 2 A and resistive load</li> <li>700,000 switching cycles at 0.5 A and resistive load</li> </ul> </li> </ul>
2	R4C		
3	R5A	N. O. contact	
4	R5C		
5	R6A	N. O. contact	
6	R6C		

# Option Terminals

## What's in This Chapter

Control Terminals at the Option Terminals .....	124
Specification of the Option control terminals .....	125

## Control Terminals at the Option Terminals

The option terminals X200 and X205 are built-in. They are designed as pluggable terminals.

### Spring terminals pluggable

Max. cable cross section: 2.5 mm<sup>2</sup> [AWG 12]

Min. cable cross section: 0.25 mm<sup>2</sup> [AWG 26]

Strip length: 10 mm

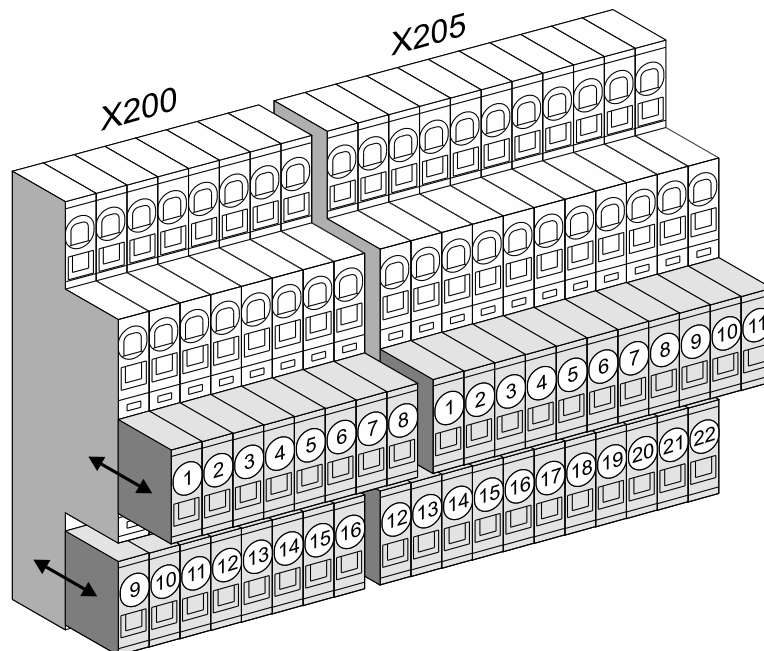

# Specification of the Option control terminals

As shown in the following illustration, there are following connections available for the customer depending on the chosen options.

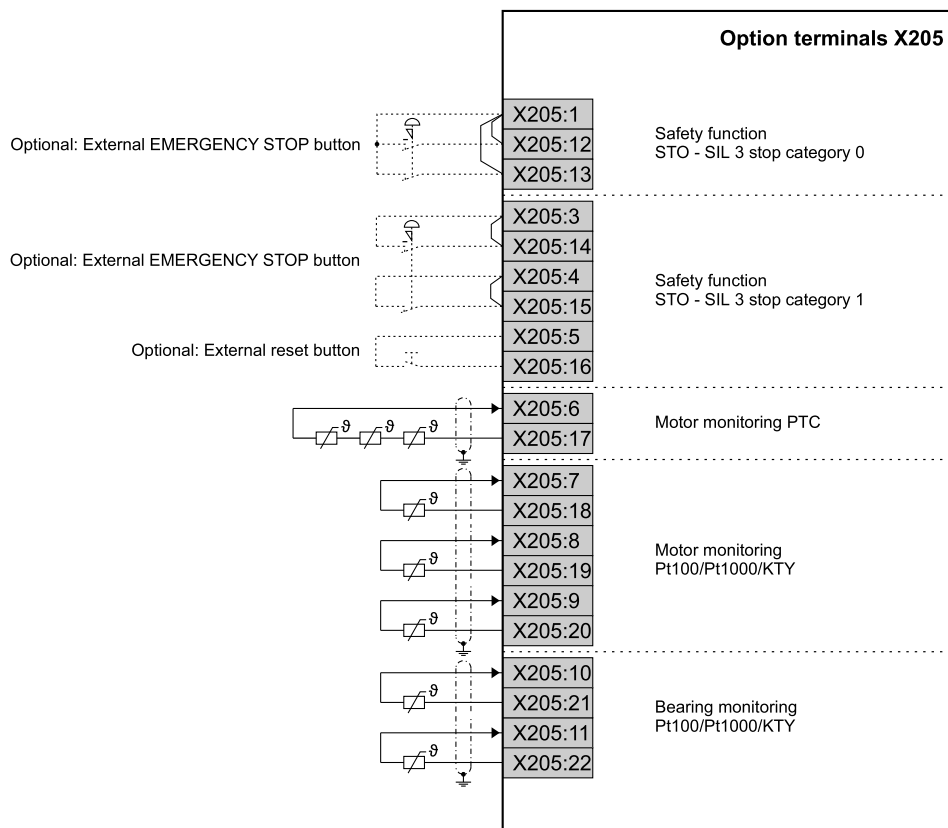
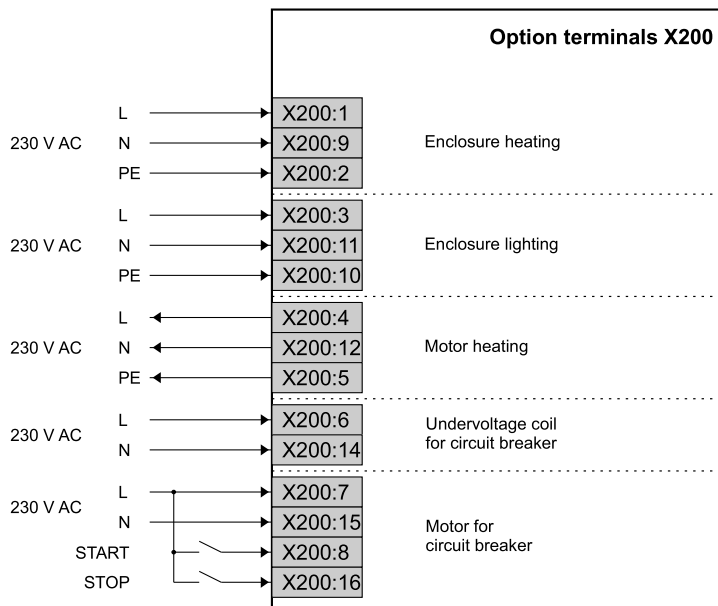

# Customizations

## What's in This Part

Enclosure Options .....	127
Control Options .....	132
I/O Expansion Cards .....	134
Communication Cards .....	136
Encoder Interface Modules .....	139
Functional Safety .....	141
Display Options .....	143
Motor Options .....	145
Mains Supply .....	149
Braking Option .....	152
EcoStruxure Asset Advisor.....	160
Documentation / Packaging .....	162

# Enclosure Options

## What's in This Chapter

General Information.....	128
Increased Protection Degree IP54 .....	128
Enclosure Plinth for Basic Device .....	129
Connection Enclosure Cable from Top .....	129
Connection Enclosure Cable from Bottom .....	129
Enclosure Lighting.....	130
Enclosure Heating .....	130
Modified Wiring Colors.....	131

## General Information

During manufacturing of the Altivar Process Drive Systems already all customizations are considered. In addition, parameter adjustments are carried out and permanently stored as factory setting, if required.

This chapter contains customizations, which we have already predefined as a result of our many years of experience in order to cover the essential requirements of our customers. But in many cases a unique system solution is necessary due to the variety of applications and requirements.

Your Drive Systems Tendering Team is looking forward to your specific request.

## Increased Protection Degree IP54

For operation with rough ambient conditions the enclosure can be designed in protection degree IP54.

So when the doors are closed the Altivar Process Drive System is protected against:

- Touching live electrical parts
- Harmful dust accumulation inside
- Penetration of spray water from all directions

Typically, IP54 enclosure units are installed production halls and manufacturing sites, where heavy dirt accumulation is expected.

Our solution contains a clearly specified and tested cooling system with a separate cooling air channel which provides highest reliability.

Via this separated cooling air channel about 90 % of the heat losses are exhausted. The interior of the enclosure is cooled via fans in the enclosure door.

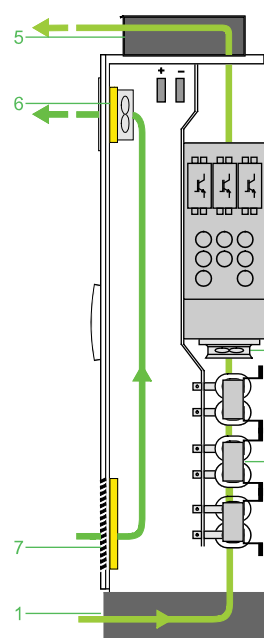

In case of increased protection degree IP54 with separate air channel the cooling air inflow for the power part takes place through the floor and the air outlet through the enclosure roof.

The control part is cooled by filter fans in the enclosure door.

1 Cooling air for power part (via enclosure plinth)

2...4 Power components (different for supply units and inverter units)

5 Air outlet through metal grid with splash water protection

6 Air outlet (with filter mat) with fans for control part

7 Air inflow grid (with filter mat) for control part

Air inflow temperature: -10...+50 °C

(below 0 °C with additional enclosure heating, above +40 °C with derating)

**NOTE:** The additional enclosure plinth increases the enclosure by 200 mm to a total height of 2350 mm.

## Enclosure Plinth for Basic Device

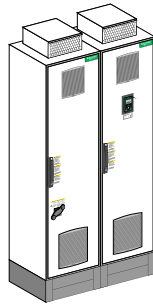

For adapting to the local conditions or for better protection of the enclosure against wet soil, the enclosure can be raised with a plinth (color: RAL 7022) by 200 mm.

So the enclosure height is increased to a total height of 2350 mm.

**NOTE:** At the customization "Increased protection degree IP54" the enclosure is already equipped with an enclosure plinth as standard.

## Connection Enclosure Cable from Top

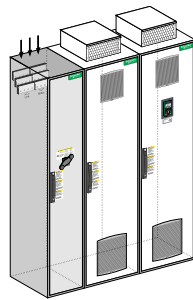

This separate connection enclosure makes it possible to insert and connect the mains cables and motor cables from the top of the enclosure.

The separated connecting enclosure contains all power terminals and the mains disconnection (e.g. main switch), which makes a voltage disconnection of the basic device during maintenance possible.

Furthermore, the connecting enclosure provides enough space for additional customizations.

**NOTE:** The additional connecting enclosure increases the total width of the enclosure.

## Connection Enclosure Cable from Bottom

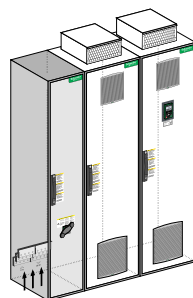

This separate connection enclosure makes it possible to insert and connect the mains cables and motor cables from the bottom of the enclosure.

The separated connecting enclosure contains all power terminals and the mains disconnection (e.g. main switch), which makes a voltage disconnection of the basic device during maintenance possible.

Furthermore, the connecting enclosure provides enough space for additional customizations.

**NOTE:** The additional connecting enclosure increases the total width of the enclosure.

## Enclosure Lighting

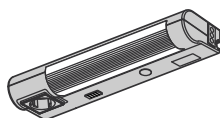

In order to make maintenance easier, the enclosure can be equipped with a lighting, which is switched on when opening the enclosure door.

The lighting is externally supplied and so it is also available at switched off mains supply. Furthermore, a power socket according to VDE standard (230 V / 50 Hz, 2 A) is located on the lighting to operate smaller consumers on-site.

- NOTE:** The additional power supply at terminals X200 has to be provided by the user.
- Rated voltage: 230 V
  - Rated frequency: 50/60 Hz
  - Rated power: 500 VA

This option requires an additional external 230 V power supply with overvoltage category 1 or 2 (according to IEC/UL 61800-5-1) connected to terminals X200.

**⚡ ⚠ DANGER**

**HAZARD OF ELECTRIC SHOCK**

Verify that the external power supply complies with all national and local electrical code requirements.

**Failure to follow these instructions will result in death or serious injury.**

## Enclosure Heating

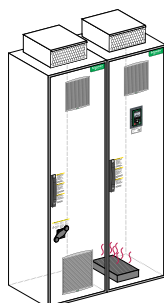

This customization is used to heat the enclosure in order to avoid frost and condensation at an ambient temperature up to -10°C. The enclosure heating is externally supplied, so the enclosure can be also heated when mains supply is switched off.

- NOTE:** The additional power supply at terminals X200 has to be provided by the user.
- Rated voltage: 230 V
  - Rated frequency: 50/60 Hz
  - Rated power: 400...800 VA

This option requires an additional external 230 V power supply with overvoltage category 1 or 2 (according to IEC/UL 61800-5-1) connected to terminals X200.

**⚡ ⚠ DANGER**

**HAZARD OF ELECTRIC SHOCK**

Verify that the external power supply complies with all national and local electrical code requirements.

**Failure to follow these instructions will result in death or serious injury.**

## Modified Wiring Colors

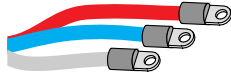

This option contains modified wiring colors as well as red, white and blue heat shrink tubes at the power cables.

# Control Options

## What's in This Chapter

Key Switch "local / remote" .....	133
Ethernet Port on Front Door .....	133

## Key Switch "local / remote"



The key switch "local / remote" allows to switch between local operation (via the graphical operating panel) or remote control (terminals or bus). The switch can be only operated with a key and so it can be only switched by authorized personnel.

## Ethernet Port on Front Door

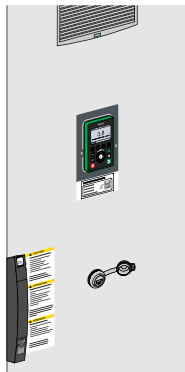

The Ethernet port in the enclosure door allows access to the frequency inverter without opening the enclosure door. The plug can be closed with a dust protection cap.

# I/O Expansion Cards

## What's in This Chapter

Expansion Card With Additional Inputs / Outputs .....	135
Expansion Card With Relay Outputs .....	135

## Expansion Card With Additional Inputs / Outputs



Expansion card for additional analog and digital inputs and outputs (6 digital inputs, 2 digital outputs, 2 analog inputs)

You will find further information at chapter Option "Logic and Analog I/O Card", page 117.

## Expansion Card With Relay Outputs

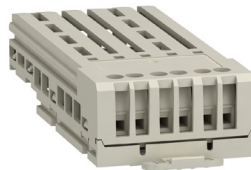

Expansion card with three additional relay outputs

You will find further information at chapter Option "Relay Output Card", page 121.

# Communication Cards

## What's in This Chapter

Communication Card CANopen Daisy Chain.....	137
Communication Card CANopen SUB-D9 .....	137
Communication Card CANopen With Spring Terminals .....	137
Communication Card DeviceNet.....	137
Communication Card Profibus DP .....	137
Communication Card PROFINET .....	138
Communication Card EtherCAT Daisy Chain.....	138

You will find detailed information in the respective documentation. See listing under chapter [Related Documents](#), page 16.

## Communication Card CANopen Daisy Chain



Option card for control of the inverter via CANopen Daisy Chain

## Communication Card CANopen SUB-D9



Option card for control of the inverter via CANopen with SUB-D port.

## Communication Card CANopen With Spring Terminals

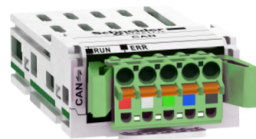

Option card for control of the inverter via CANopen with spring terminals

## Communication Card DeviceNet

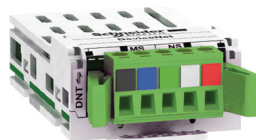

Option card for control of the inverter via DeviceNet

## Communication Card Profibus DP

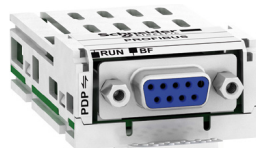

Option card for control of the inverter via Profibus DP V1

## Communication Card PROFINET

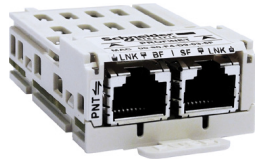

Option card for control of the inverter via PROFINET

## Communication Card EtherCAT Daisy Chain



Option card for control of the inverter via EtherCAT Daisy Chain

# Encoder Interface Modules

## What's in This Chapter

Digital Encoder Interface Module 5/12 V.....	140
Analog Encoder Interface Module.....	140
Resolver Interface Module .....	140
HTL Encoder Interface Module.....	140

You will find detailed information in the respective documentation. See listing under chapter [Related Documents](#), page 16.

## Digital Encoder Interface Module 5/12 V



Interface module for connecting a digital encoder

## Analog Encoder Interface Module



Interface module for connecting an analog encoder

## Resolver Interface Module



Interface module for connecting a resolver

## HTL Encoder Interface Module



Interface module for connecting an encoder with push-pull (HTL) output driver

# Functional Safety

## What's in This Chapter

Safe Torque Off (STO) .....	142
SIL 3 Stop Category 0 / Performance Level PL e.....	142
SIL 3 Stop Category 1 / Performance Level PL e.....	142

## Safe Torque Off (STO)

The Altivar Process is equipped with the safety function "Safe Torque Off STO" according to ISO 13849-1, IEC/EN 61508, IEC/EN 60204-1, which helps to prevent any unintended start-up of the motor.

- Inputs  $\overline{\text{STOA}}$  and  $\overline{\text{STOB}}$  directly at the control terminals of the control block. This function fulfills, when correctly wired, the machine standard ISO 13849-1, Performance level PL e, the IEC/EN 61508 Safety integrity level SIL 3 standard for functional safety and the power drive system standard IEC/EN 61800-5-2.
- Customization SIL3, stop category 0 / PL e  
The triggering of the safety function leads to a coast down of the drive and helps to prevent an unintended restart.
- Customization SIL3, stop category 1 / PL e  
The triggering of this function starts a controlled deceleration, shuts down the drive after the set time and helps to prevent an unintended restart.

**NOTE:** You will find further information in the Safety Function Manual (NHA80947).

## SIL 3 Stop Category 0 / Performance Level PL e

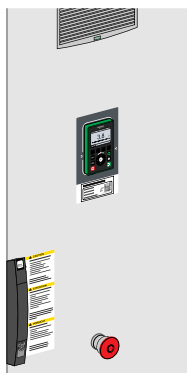

Via an EMERGENCY STOP button in the enclosure door or further implemented, external monitoring equipment, the torque at the motor can be switched off according SIL 3 stop category 0 / performance level PL e.

The triggering of the safety function leads to a coast down of the drive and helps to prevent an unintended restart.

## SIL 3 Stop Category 1 / Performance Level PL e

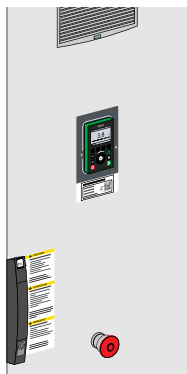

Via an EMERGENCY STOP button in the enclosure door or further implemented, external monitoring equipment, the torque at the motor can be switched off according SIL 3 stop category 1 / performance level PL e.

The triggering of this function starts a controlled deceleration, shuts down the drive after the set time and helps to prevent an unintended restart.

# Display Options

## What's in This Chapter

Front Display Module (FDM) .....	144
Indicator Lamps on Front Door .....	144

## Front Display Module (FDM)

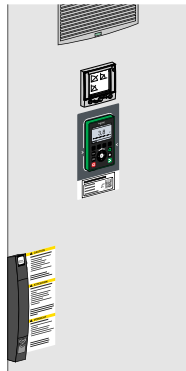

A display element mounted in the enclosure door enables clear indication of real-time values like:

- Indication of mains currents (3x)
- Mains voltages (3x phase voltages, 3x phase-to-phase voltages)
- Mains power

These values can be indicated graphically or digital.

The display element is provided with backlight for increased readability.

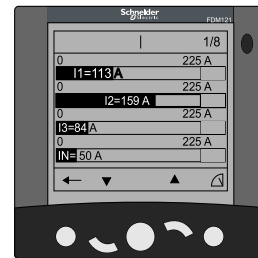

## Indicator Lamps on Front Door

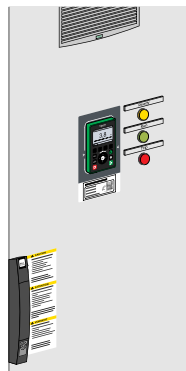

For quick, optical diagnostics of the actual operating state from a greater distance, the enclosure can be equipped with indicator lamps.

The lamps show following operating states:

Operating state	Indicator lamp	Labeling
Ready	Yellow	READY
Operation	Green	RUN
Detected fault	Red	TRIP

# Motor Options

## What's in This Chapter

Motor Monitoring PTC.....	146
Motor Monitoring PTC with ATEX Certificate.....	146
Motor monitoring Pt100/Pt1000/KTY.....	146
Bearing Monitoring Pt100/Pt1000/KTY.....	147
dv/dt Filter Choke 150 m.....	147
dv/dt Filter Choke 300 m.....	147
Motor Heating.....	148

## Motor Monitoring PTC

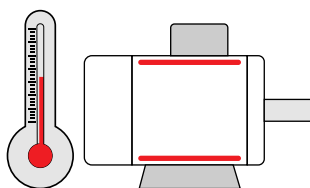

If the motor is equipped with integrated thermistor sensors to help to protect against thermal overload, they can be directly connected to a thermistor relay inside the Altivar Process Drive System.

If the frequency inverter detects an overtemperature at the motor, the drive stops the motor and generates an error message at the display. This operating state is also forwarded to the status relays and to the fieldbus.

**NOTE:** When protective separation of the thermistor sensors in the motor cannot be guaranteed or in case of long motor cables, this option is highly recommended.

## Motor Monitoring PTC with ATEX Certificate

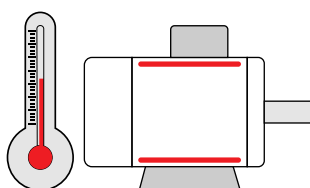

The motor monitoring PTC with ATEX certificate is used to monitor the thermistor sensors of motors which are installed in hazardous area (explosive atmosphere).

If the frequency inverter detects the overtemperature at the motor, the drive stops the motor and generates an error message at the display. This operating state is also forwarded to the status relays and to the fieldbus. The monitoring relay additionally triggers a safe shut-down of the drive.

This equipment has been designed to operate outside of any hazardous location. Only install this equipment in zones known to be free of a hazardous atmosphere.

<b>⚠ DANGER</b>
<b>POTENTIAL FOR EXPLOSION</b>
Install and use this equipment in non-hazardous locations only.
<b>Failure to follow these instructions will result in death or serious injury.</b>

## Motor monitoring Pt100/Pt1000/KTY

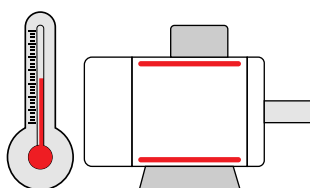

If the motor is equipped with integrated temperature sensors (Pt100, Pt1000, KTY 83/84) in the winding to help to protect against thermal overload, they can be directly connected to the relay inside the Altivar Process Drive System.

If the set temperature at the motor is exceeded, a warning message is generated. When the temperature is further rising over a set value, the drive is stopped and an error message is generated. The operating states are also forwarded to the status relays and to the fieldbus.

**NOTE:** When protective separation of the thermistor sensors in the motor cannot be guaranteed or in case of long motor cables, this option is highly recommended.

## Bearing Monitoring Pt100/Pt1000/KTY

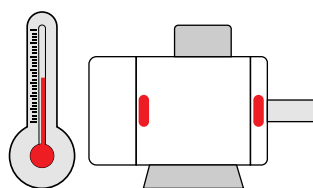

If the motor is equipped with integrated temperature sensors (Pt100, Pt1000, KTY 83/84) in the bearings to help to protect against thermal overload, they can be directly connected to the relay inside the Altivar Process Drive System.

If the set temperature at the motor is exceeded, a warning message is generated. When the temperature is further rising over a set value, the drive is stopped and an error message is generated. The operating states are also forwarded to the status relays and to the fieldbus.

**NOTE:** When protective separation of the thermistor sensors in the motor cannot be guaranteed or in case of long motor cables, this option is highly recommended.

## dv/dt Filter Choke 150 m

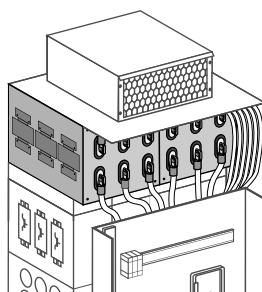

The use of the customization dv/dt filter choke 150 m has significant advantages concerning the operation of the drive:

- Decrease of the dv/dt and peak voltage load of the motor
- Prevention of common mode bearing currents in the motor – especially important at high power
- Great reduction of the influences to other cables – important if the separate laying of motor cables is not possible
- In case of long motor cables up to 150 m shielded or up to 250 m unshielded
- dv/dt filter choke 150 m can be installed without enlarged enclosure width.

**NOTE:** You will find further information about long motor cables under chapter Length of Motor Cables, page 91.

## dv/dt Filter Choke 300 m

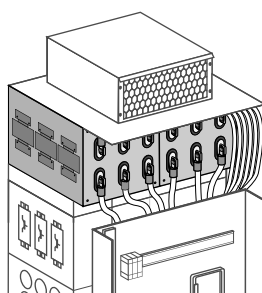

The use of the customization dv/dt filter choke 300 m has significant advantages concerning the operation of the drive:

- Decrease of the dv/dt and peak voltage load of the motor
- Prevention of common mode bearing currents in the motor – especially important at high power
- Great reduction of the influences to other cables – important if the separate laying of motor cables is not ensured
- In case of long motor cables up to 300 m shielded or up to 500 m unshielded
- dv/dt filter choke 300 m can be installed without enlarged enclosure width.

**NOTE:** You will find further information about long motor cables under chapter Length of Motor Cables, page 91.

## Motor Heating

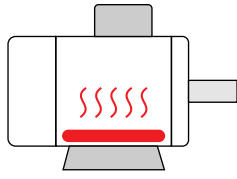

The motor standstill heating is used to avoid condensate and frost damages at standstill of the motors in cold environment. It is activated when the motor is shut down.

# Mains Supply

## What's in This Chapter

Circuit Breaker .....	150
Undervoltage Coil for Circuit Breaker 230 V .....	150
Motor for Circuit Breaker 230 V .....	151

## Circuit Breaker

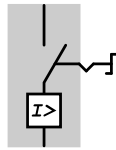

The circuit breaker is used for mains disconnection instead of the main switch. It is operated by a handle in the enclosure door.

The circuit breaker can be optionally equipped with an undervoltage coil and motor.

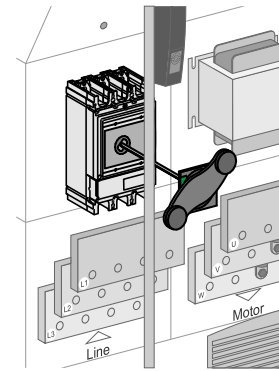

## Undervoltage Coil for Circuit Breaker 230 V

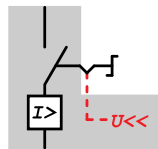

When there is no voltage at the undervoltage coil, the circuit breaker switches off. The undervoltage coil is built into the circuit breaker and is wired to the option terminals.

### Specification of the control terminals

X200: 6/14      External control voltage  
220...240 V AC 50/60 Hz

- NOTE:**
- Only when control voltage is applied, the circuit breaker can be switched on manually.
  - You will find further information about the topic wiring under chapter Option Terminals, page 123.

## Motor for Circuit Breaker 230 V

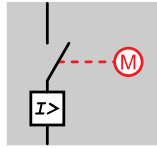

Remote control of the circuit breaker via control commands is possible by means of this motor drive. The motor drive is built into the circuit breaker and is wired to the option terminals.

### Specification of the control terminals

X200: 7/15	External control voltage 220...240 V AC 50/60 Hz
X200: 8	Start request
X200: 16	Stop request

### Specification of the motor drive:

External control circuit voltage:
• 230 V AC $\pm$ 5% 50/60 Hz
Reaction time:
• < 80 ms when closing
• < 600 ms when opening
Power input:
• $\leq$ 500 VA when closing
• $\leq$ 500 VA when opening

### NOTE:

- At this customization no handle for the circuit breaker is possible.
- You will find further information about the topic wiring under chapter Option Terminals, page 123.
- You will find further information about the topic switching rate under chapter Switching Rate, page 38.

# Braking Option

## What's in This Chapter

Braking Unit Option BUO .....	153
Braking Resistors BR.....	157

## Braking Unit Option BUO

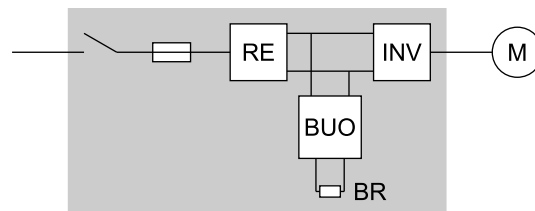

The use of a braking unit is required, if:

- More power is returned to the DC link during the braking procedure than the losses in the motor and the inverter amount to or
- The application requires very short braking times.

The braking unit option BUO is placed in an own enclosure and is equipped with a voltage regulation to control the braking transistors.

If the DC link voltage exceeds an adjustable value, the external braking resistor is switched into the DC link as a consumer. The braking resistor converts the power incurred during generator operation into heat. This helps to avoid a further rising of the DC link voltage and thus a shut-down with overvoltage.

The key benefits of the braking unit option BUO are:

- Significant reduction of capacitor load due to three-phase design
- Monitoring of the braking resistors for overload and interruption
- Shielded braking unit lines allow the compliance with the EMC limits
- Integrated protection against short-circuits and ground faults for the braking resistor and the wiring

The braking unit option BUO has following features and characteristics:

- The ModBuo●●● braking option is 3-phase designed and so it requires three braking resistors (possibly in a housing with six terminals).
- The braking option ModBuo●●● controls itself. But for monitoring the function there is an additional internal bus connection to the frequency inverter. So all settings and displays can take place at the interface of the inverter.
- The braking resistor is monitored for short-circuit and interruption; provided that the nominal power of the resistor is correctly set. The protection against ground faults is realized via the integrated circuit breaker.
- For monitoring and diagnostics all braking resistors are subsumed to one group.
- For simple applications it is possible to assign a braking unit and braking resistors with less power.
- If the installed peak braking power is not sufficient, the inverter automatically extends the deceleration ramp in order to prevent a shut-down. However, if short braking times must be kept, select a braking resistor according to the maximum braking power.

**Technical Data Braking Unit**

Braking unit	ModBuo	C16•4	C31•4	C50•4	C63•4	C80•4
<b>Nominal data</b>						
Size	Single Drive System	1c			2c	
Braking voltage max.		780 V dc	780 V dc	780 V dc	780 V dc	780 V dc
<b>Braking power</b>						
At 780 V dc	12s / 240s (= 5%)	200 kW	400 kW	600 kW	800 kW	1000 kW
At 755 V dc	12s / 240s (= 5%)	180 kW	360 kW	540 kW	720 kW	900 kW
At 720 V dc	12s / 240s (=5%)	170 kW	340 kW	510 kW	680 kW	850 kW
	36s / 240s (= 15%)	150 kW	300 kW	450 kW	600 kW	750 kW
	120s / 240s (= 50%)	120 kW	240 kW	360 kW	480 kW	600 kW
	Continuous operation (= 100%)	100 kW	200 kW	300 kW	400 kW	500 kW
<b>Braking resistor</b>						
Braking resistor	Min. (1)	3x 6.0 Ω	3x 3.0 Ω	3x 2.2 Ω	6x 3.0 Ω	6x 2.6 Ω
	Max. (2)	3x 8.0 Ω	3x 4.0 Ω	3x 2.7 Ω	6x 4.0 Ω	6x 3.4 Ω
<b>Characteristics</b>						
Maximum current $I_{max}$		85	170	255	340	425
<b>Heat losses at cont. operation</b>						
	Total losses	1050 W	1600 W	2200 W	3300 W	3600 W
	Control part only	280 W	310 W	350 W	460 W	510 W
Auxiliary voltage 230V, 50/60Hz		250 W	250 W	250 W	500 W	500 W
Enclosure width		400 mm			800 mm	
Weight	Net	260 kg	260 kg	260 kg	510 kg	510 kg
	Gross	270 kg	270 kg	270 kg	530 kg	530 kg
Arrangement	Single Drive System	Right			Right	
<b>Ambient conditions</b>						
Air flow	Power part	580 m³/h	580 m³/h	580 m³/h	1160 m³/h	1160 m³/h
	Control part	140 m³/h	140 m³/h	140 m³/h	280 m³/h	280 m³/h
<b>Cable cross section</b>						
Number of terminals		6			12	
Cable cross section	Per terminal	2x M12			2x M12	
Max. cross-section		4x 120mm²			4x 120mm²	
(1)	Nominal value of the braking resistance which may not fall short due to help to protect the braking transistor (-10 % tolerance)					
(2)	Nominal resistance value at which a peak braking power of 125...150 % of the nominal inverter power HD (Heavy Duty) can still be reached (+25 % tolerance including temperature rise)					

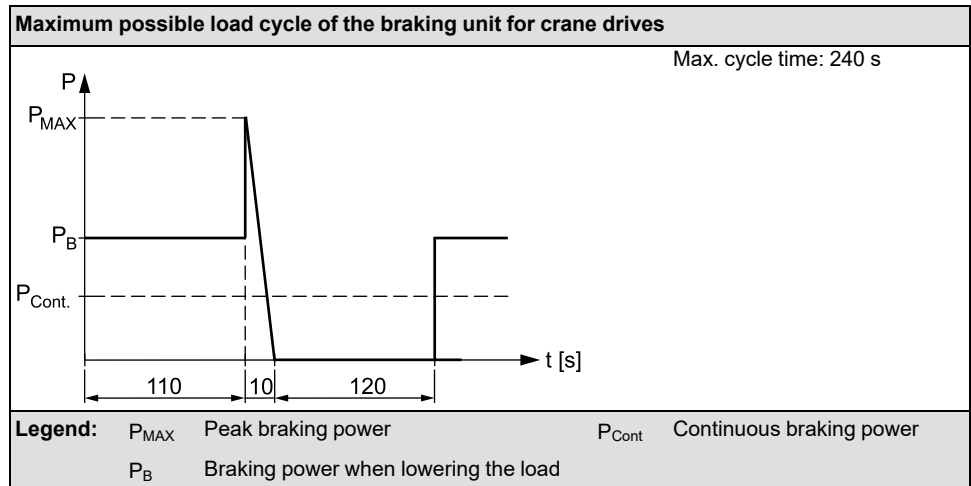

**Dimensions Braking Unit Option IP23 Size 1c / 1mc**

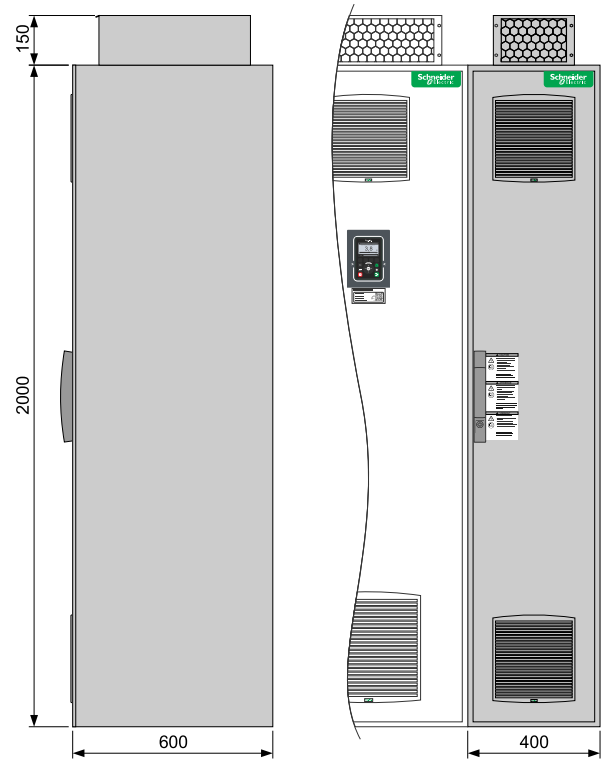

**Interior View Braking Unit Option IP23 for Size 1c / 1mc**

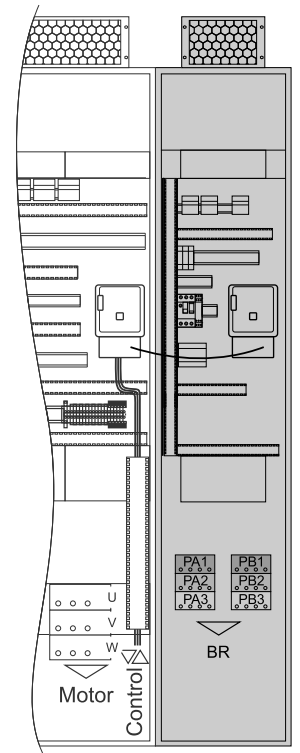

**NOTE:** At protection degree IP54 the enclosure height is increased by 200 mm.

**Dimensions Braking Unit Option IP23 Size 2c / 2mc**

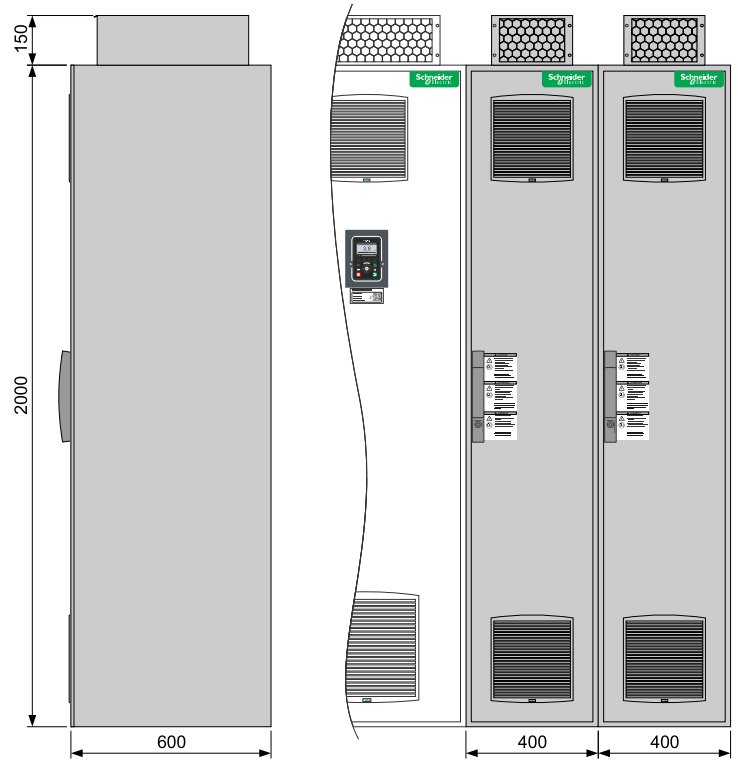

**Interior View Braking Unit Option IP23 for Size 2c / 2mc**

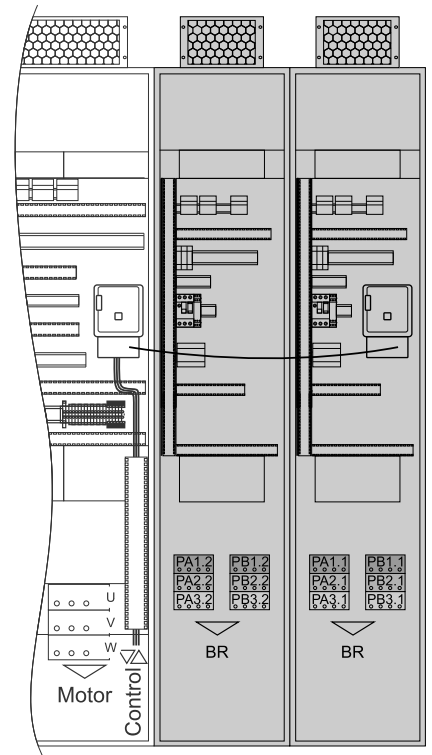

**NOTE:** At protection degree IP54 the enclosure height is increased by 200 mm.

# Braking Resistors BR

The braking resistor converts the power accumulating during generator operation into heat and thus helps to prevent a further rising of the DC link voltage.

Braking resistors can be only connected to Drive Systems which are equipped with an braking unit option BUO.

When allocating the braking resistors to the frequency inverters, observe the following points:

- Minimum braking resistance per inverter power
- Required peak braking power and cycle time
- Necessary continuous power depending on the application requirements
- Recommended assignment of braking resistors

Choose a suitable place for installing the braking resistors where the energy can dissipate unhindered via the ambient air.

Thereby the surface of the resistor may reach up to 250°C. So the braking resistor must be mounted on non-combustible material.

The unhindered air flow may not be impaired by other devices or casing parts!

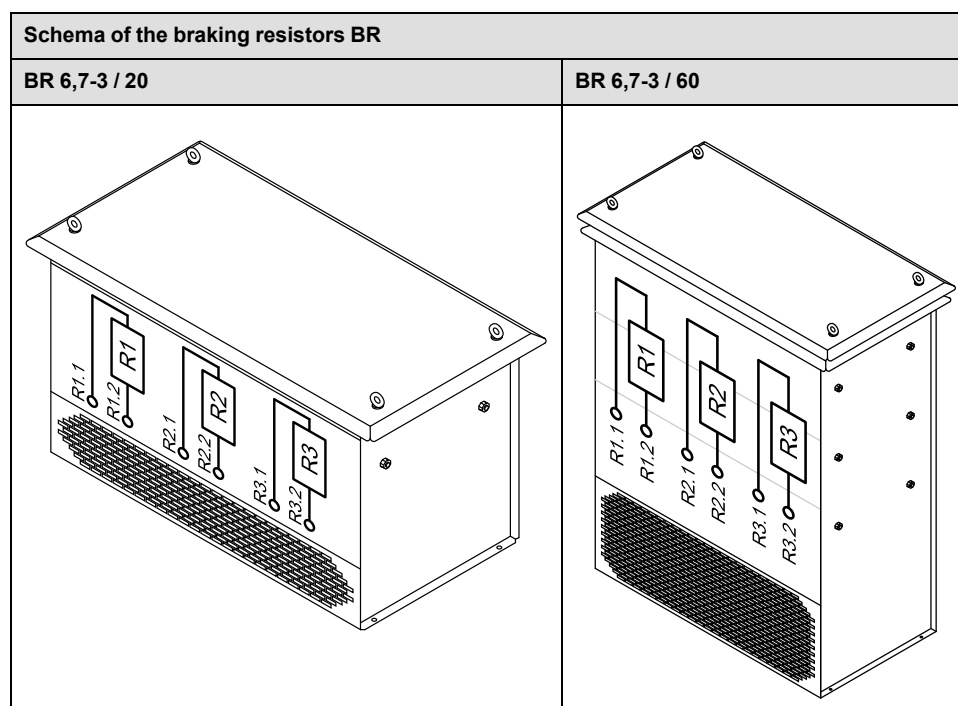

The temperature of the products described in this manual may exceed 80 °C (176 °F) during operation.

## ▲ WARNING

### HOT SURFACES

- Ensure that any contact with hot surfaces is avoided.
- Do not allow flammable or heat-sensitive parts in the immediate vicinity of hot surfaces.
- Verify that the product has sufficiently cooled down before handling it.
- Verify that the heat dissipation is sufficient by performing a test run under maximum load conditions.

**Failure to follow these instructions can result in death, serious injury, or equipment damage.**

**Technical Data Braking Resistor**

General technical data	
Nominal tolerance at 20°C	±10 %; additionally +15 % resulting from the temperature rise during operation
Thermal protection	Software function in the Drive System (or by a thermal relay / motor protection relay)
Ambient conditions	
Ambient temperature	-25...+40 °C; above +40 °C with derating of 4 % per 10 K
Storage / Transport temperature	-25...+70 °C
Cooling	Natural convection
Thermal time constant	140 s <sup>(1)</sup>
Protection degree	IP23
Altitude	Up to 1000 m, above with derating of 1 % per 100 m
Standards	
Standards	CE <sup>(2)</sup>
<p>(1) Set this value via parameter [Braking Resist T Constant] brTC.</p> <p>(2) For applications, which require a UL certification, you can choose resistors from the Schneider Electric standard program (e.g. 3x VW3A7755 instead of 1x VW3A7791).</p>	

Braking resistor	BR 6,7-3 / 20	BR 6,7-3 / 60
Reference number	VW3A7790	VW3A7791
Nominal data		
Resistance	3x 6.7 Ω	3x 6.7 Ω
Continuous power total	20 kW	60 kW
Parameter <i>brP</i> (x number of resistors connected in parallel)	20	60
Peak braking power at 120 s cycle repetitive		
At 680 V dc	150 kW (max. 7 % duty cycle)	150 kW (max. 24 % duty cycle)
At 780 V dc	200 kW (max. 5 % duty cycle)	200 kW (max. 18 % duty cycle)
At 975 V dc	300 kW (max. 3 % duty cycle)	300 kW (max. 11 % duty cycle)
At 1075 V dc	380 kW (max. 2 % duty cycle)	380 kW (max. 8 % duty cycle)
Duty cycle ED and cycle time		
At 115 kW braking power	12 % duty cycle at 120 s cycle (tON = 15 s, tOFF = 105 s; repetitive)	50 % duty cycle at 120 s cycle (tON = 60 s, tOFF = 60 s; max. 3 cycles, then at least 20 min. pause)
		40 % duty cycle at 120 s cycle (tON = 48 s, tOFF = 72 s; repetitive)
		30 % duty cycle at 200 s cycle (tON = 60 s, tOFF = 140 s; repetitive)
Characteristics		
Setting value thermal relay	35 A per phase	55 A per phase
Weight	Net	50 kg
	Gross	70 kg
Connection		
Connection	6x M10 2x M10 for PE	6x M10 2x M10 for PE

**Dimensions BR 6,7-3 / 20**

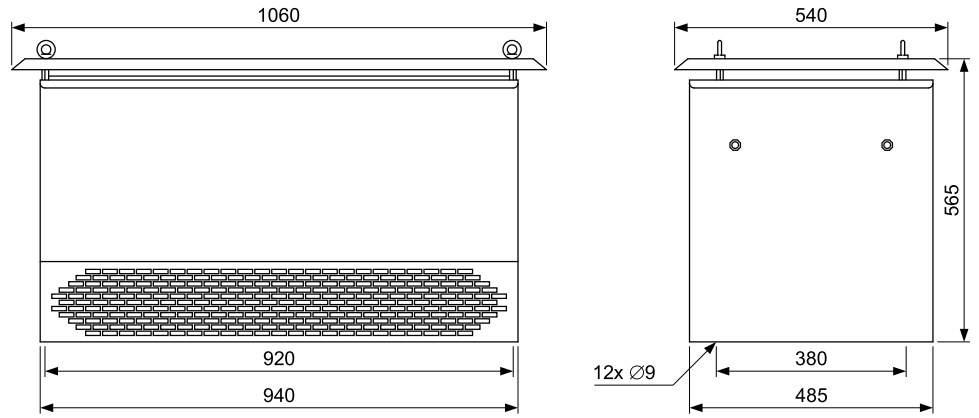

**Dimensions BR 6,7-3 / 60**

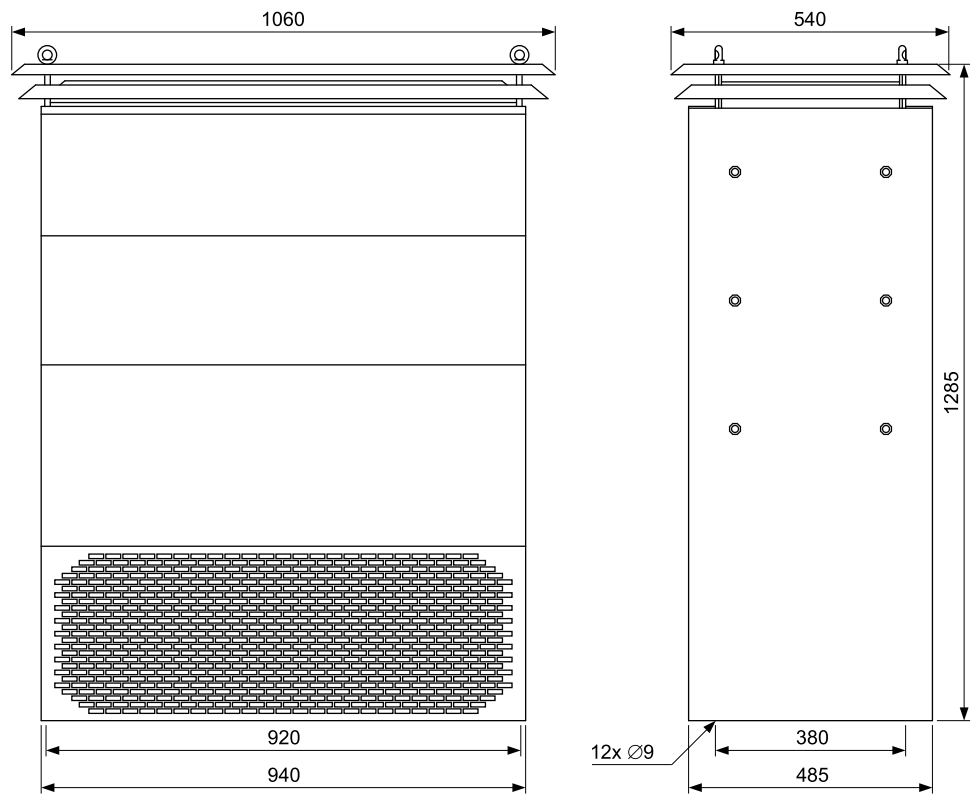

# EcoStruxure Asset Advisor

EcoStruxure Asset Advisor is part and fully integrated in the unique Schneider Electric EcoStruxure platform and helps to reduce risks for personnel and increase operational continuity of your installation.

Asset Advisor is integrated in the “Apps, Analytics & Services” layer and provide cloud based monitoring and smart alarming services.

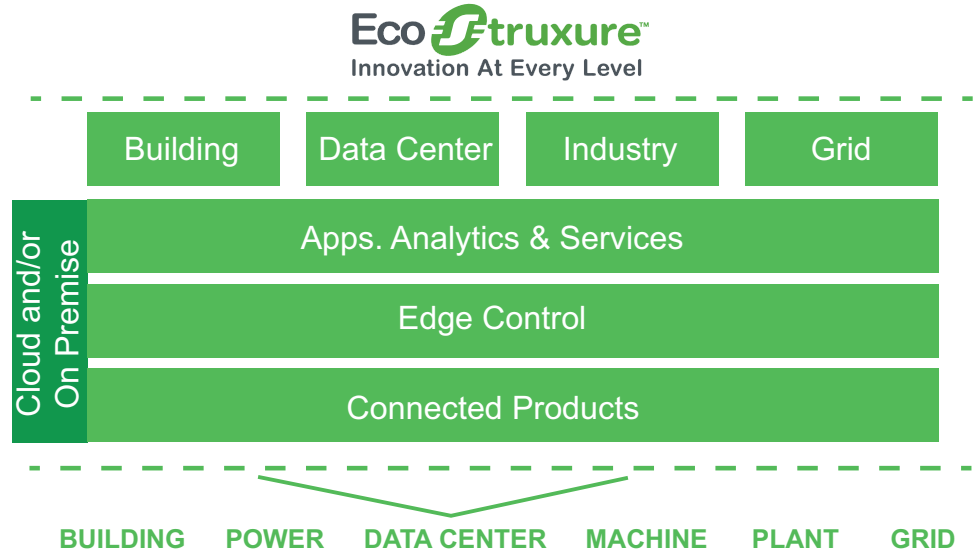

Altivar Process Drives belong to the “Connected Products” layer of EcoStruxure and provide solutions to optimize the operation and maintenance of your drives installation.

Utilizing newest technologies seamless integrated into Schneider Electric Managed Services and IoT architecture, you benefit from predictive maintenance effectiveness.

It allows you to manage maintenance tasks on your assets based on condition based monitoring and predictive analytics. All thanks to the combination of smart connected device technologies and powerful cloud-based risk prediction capabilities. An Altivar Process with EcoStruxure Asset Advisor transforms data into insight and help to run your operations more efficiently and safer, with more availability, and increased profits.

In summary the Asset Advisor functionality can be described in 3 steps:

### Continuous health monitoring

The operator gets a health monitoring view of its assets and conditions of usage (extensive drive information and essential data from peripheral equipment). These assets act as super-sensors providing relevant data and KPIs.

### Risk evaluation

The operator knows where and what risks are on the installation. Predictive analytics constantly evaluates the level and criticality of risk by looking at an asset, the process duty cycle, and the condition of usage. This enables the ability to predict, in advance, a potential failure or dysfunction of the installation.

### Risk mitigation

The operator receives notification of the necessary maintenance task required at the right time to secure the asset and production at minimal cost, mitigating the risks of downtime.



# Documentation / Packaging

## What's in This Chapter

Safety Labels in Local Language .....	163
Seaworthy Packaging .....	163

## Safety Labels in Local Language

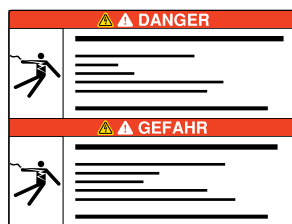

All Altivar Process Drive Systems are delivered with safety labels in English and French. Optionally the devices can be also ordered with labels in the local language.

## Seaworthy Packaging

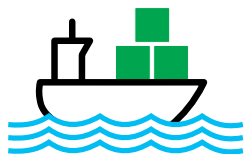

This option contains a seaworthy packaging for transport by ship. The packaging complies with the HPE packaging guidelines (federal association for wooden packages, pallets and export packaging in Germany).





Schneider Electric  
35 rue Joseph Monier  
92500 Rueil Malmaison  
France

+ 33 (0) 1 41 29 70 00

[www.se.com](http://www.se.com)

As standards, specifications, and design change from time to time, please ask for confirmation of the information given in this publication.

© 2016 – 2025 Schneider Electric. All rights reserved.

NHA37117.03