

# 10—OsiSense™ XG Radio Frequency Identification System 13.56 MHz

---

<b>Selection guide</b> .....	<b>10/2</b>
■ Introduction, Description .....	10/4
■ Specifications .....	10/10
■ Catalog Numbers .....	10/13
■ Dimensions .....	10/17
■ Connections .....	10/20
■ Operating Curves .....	10/22
■ Mounting Distances .....	10/23

# OsiSense™ XG

## Radio Frequency Identification System

### 13.56 MHz

**Applications** Numerous and varying applications in the industrial, logistic, and building sectors: flexible production workshops, traceability, access control, etc.

**Compact stations, 13.56 MHz** Flat form 40 Flat form 80



<b>Dimensions, W x H x D (mm)</b>	40 x 40 x 15	80 x 80 x 26
<b>Protocols</b>	Modbus™ RTU and Uni-Telway™	
<b>Nominal sensing distance depending on associated tag, mm (in.)</b>	18 to 70 (0.71 to 2.76)	20 to 100 (0.79 to 3.94)
<b>Station type</b>	<b>XGCS4901201</b>	<b>XGCS8901201</b>
<b>Page</b>	10/17	



<b>Dimensions, W x H x D (mm)</b>	40 x 40 x 15					54 x 85.5 x 0.8	Ø 30 x 3	Ø 30 x 3	26 x 26 x 13	M18 x 1 x 12	40 x 11		
<b>Type of memory</b>	EEPROM		FeRAM			EEPROM		FeRAM		EEPROM			
<b>Memory capacity (bytes)</b>	3,408	13,632	2,000	8,192	32,768	256	112	2,000	64				
<b>Nominal sensing distance, mm (in.) (3)</b>	<b>With station XGCS49●</b>		33 (1.30)	30 (1.18)	45 (1.77)	25 (0.98)	25 (0.98)	70 (2.76)	48 (1.89)	45 (1.77)	40 (1.57)	18 (0.71)	30–39 (1.18–1.54 in.)
	<b>With station XGCS89●</b>		48 (1.89)	40 (1.57)	65 (2.56)	39 (1.54)	39 (1.54)	100 (3.94)	65 (2.56)	65 (2.56)	55 (2.17)	20 (0.79)	35–46 (1.38–1.81 in.)
<b>Time (ms) (4)</b>	<b>Read (2)</b>		9.25 + 0.375 x n	16.25 + 0.375 x n	7+ 2 x n	6+ 0.25 x n	6+ 0.25 x n	12+ 0.825 x n	7+ 2 x n		12+ 0.825 x n		12+ 0.825 x n
	<b>Write (2)</b>		13+ 0.8 x n	20+ 0.8 x n	7+ 2.4 x n	6+ 0.25 x n	6+ 0.25 x n	20+ 11.8 x n	12+ 5.6 x n	7+ 2.4 x n	20+ 11.8 x n	19+ 4.1 x n	20+ 11.8 x n
<b>Tag type</b>	<b>XGH B444345</b>	<b>XGH B445345</b>	<b>XGH B440245</b>	<b>XGH B440845</b>	<b>XGH B443245</b>	<b>XGH B90E340</b>	<b>XGH B320345</b>	<b>XGH B320246</b>	<b>XGH B221346</b>	<b>XGH B211345</b>	<b>XGH B411346</b>		
<b>Page</b>	16												

(1) Customized versions on request.



(2) n = number of 16-bit words.

(3) Metal mounted. See the sensing distances under "Minimum permissible mounting distances in a metal structure" on page 10/22.

(4) Does not include the network transfer time.

New

<b>Connection boxes</b>	<b>Ethernet box</b>	<b>Tap-off box</b>	<b>Profibus™ box</b>	<b>Ethernet IP splitter box</b>
				
<b>Protocols</b>	Modbus TCP/IP	Modbus and Uni-Telway	Profibus-DP	Ethernet/IP
<b>Associated compact stations</b>	XGCS49● and XGCS89●			
<b>Supply voltage</b>	--- 24 Vdc			
<b>Connection box type</b>	<b>XGSZ33ETH</b>	<b>TCSAMT31FP</b>	<b>XGSZ33PDP</b>	<b>XGSZ33EIP</b>
<b>Page</b>	6			

<b>Field expanders</b>	<b>Conveying type</b>	<b>Universal type</b>	
			
<b>Dimensions, W x H x D (mm)</b>	400 x 23 x 50	200 x 23 x 50	250 x 250 x 10
<b>Dialogue area, W x H (mm)</b>	380 x 45	190 x 45	230 x 230
<b>Associated compact stations</b>	XGCS4901201		
<b>Nominal sensing distance depending on associated tag (mm)</b>	30 to 90		26 to 150
<b>Field expander type</b>	<b>XGFEC540</b>	<b>XGFEC520</b>	<b>XGFEC2525</b>
<b>Page</b>	7		

<b>Portable terminal</b>	<b>For 13.56 MHz RFID diagnostics</b>
	
<b>Function</b>	Read/Write operations on electronic tags and diagnostics on compact stations
<b>Operating system</b>	Microsoft Windows CE.NET Professional version 4.2
<b>Terminal type</b>	<b>XGSTP401</b>
<b>Page</b>	10/13
<b>OsiSense XG accessories</b>	Cables, adaptors, mounting plates, etc.
<b>Pages</b>	10/14 to 10/16

#### Operating principle

RFID is a term used for radio frequency identification systems. The frequencies range between 50 kHz and 2.5 GHz. The most widely used is 13.56 MHz.

The OsiSense XG radio frequency identification system allows you to perform functions such as object traceability, object tracking, and access control. Information is stored in an accessible memory bank using a simple radio frequency link. This memory bank is in the form of an electronic tag, which contains an antenna and an integrated circuit.

The tag contains the information associated with the object to which the tag is attached. When a tag passes through the field generated by the smart antenna, it detects the signal and exchanges the read or write data between its memory and the smart antenna.

The applications are numerous and include the following:

- Logistics: dispatch, receipt, transit
- Tracking and sorting of baggage
- Automatic tolls
- Access control

The OsiSense XG radio frequency identification system is also suited to difficult environments (such as humidity, temperature, mechanical shock, vibration, dust).

#### OsiSense XG Radio Frequency Identification System

The OsiSense XG radio frequency identification system is open to the majority of ISO 18000-3, ISO 15693 and ISO 14443 electronic tags.

The XG RFID system integrates Modbus RTU, Uni-Telway, Modbus TCP/IP, and Profibus-DP, and Ethernet/IP protocols.

The OsiSense XG RFID system offer includes:

- Two models of 13.56 MHz compact smart antenna (read/write)
- Eleven models of 13.56 MHz electronic tags
- One portable RFID diagnostics terminal
- Four models of network connection boxes
- Two models of patented field expanders (accessories that allow you to adapt the shape of the dialog zone between the tag and the compact smart antenna)
- Connection and mounting accessories

#### Setup

XG RFID compact smart antennas are simple to set up, thanks to the following features:

- Integrated RFID and network functions
- No programming
- Automatic detection of the RFID electronic tags (read or write)
- Automatic setting of the communication parameters (such as speed, format, parity, protocol)
- Configuration of the network address (1 to 15) using the badge included with the smart antenna
- Read/write compatibility with the majority of 13.56 MHz tags on the market
- Low sensitivity to metal environments

#### Installation

The XG RFID smart antennas are compact and robust. They can easily be integrated into flexible manufacturing production lines in the following ways:

- quick connection using the M12 connector
- clip-on mounting

An extensive range of connecting cables and connection boxes allow the OsiSense XG smart antennas to be easily connected to industrial communication networks.

#### Description

##### XG RFID 13.56 MHz compact smart antennas (1)

XGCS smart antennas allow the reading and writing of 13.56 MHz RFID tags that comply to standards ISO 15693, ISO 14443 A and B, and ISO 18000-3.

2 models of XG RFID compact smart antennas are available:

- Flat form 40 compact smart antenna: XGCS490●●●●:
  - Dimensions (mm): 40 x 40 x 15
  - Nominal sensing distance: 18–70 mm (0.71–2.76 in.), depending on the associated tag
- Flat form 80 compact smart antenna: XGCS890●●●●:
  - Dimensions (mm): 80 x 80 x 26
  - Nominal sensing distance: 20–100 mm (0.79–3.94 in.), depending on the associated tag

(1) For smart antenna and tag selection according to passing speeds, see page 13.



Compact smart antenna, Flat form 40



Compact smart antenna, Flat form 80

# OsiSense™ XG

## Radio Frequency Identification System

### 13.56 MHz

#### XG RFID 13.56 MHz compact smart antennas (continued)

■ **Functions integrated into compact smart antennas:** XG RFID compact smart antennas integrate functions that simplify communication among the tags, the smart antennas, and the controller (PLC, PC, etc.). These built-in functions are activated by standard reading/writing of word requests sent by the PLC:

- **Firmware version:** the smart antenna is interrogated to read its version
- **Reset:** the smart antenna is reinitialized and assumes its factory default configuration (network address at 1, transmission speed at 19,200 Bd, parameters deleted)
- **Init:** the smart antenna is reinitialized and operates as if reconnected to the supply (address unchanged, transmission speed unchanged, parameters deleted)
- **Sleep mode:** the transmission of the electromagnetic field of the smart antenna is only activated on its receipt of a read or write instruction. This mode reduces the power consumption of the smart antenna and enables the suppression of interference when the smart antennas are close to each other
- **Auto Read/Write:** This mode enables the smart antenna to automatically execute up to 10 read or write instructions (up to 128 write words and up to 126 read words) in a tag as soon as it enters the dialog zone

#### XG RFID electronic tags (1)

XGHB electronic tags offer the following advantages:

- fast access to the data
- wide range of memory capacities
- security of access to the contents
- operation without battery
- positioning flexibility
- protection suited to the environmental conditions

The nominal transmission distance is 18–100 mm (0.70–3.93 in.) depending on the model of the tag and the associated compact smart antenna.

#### Portable 13.56 MHz RFID diagnostics terminal

The portable terminal **XGSTP401** is designed for use in industrial applications. Its rugged structure combined with its numerous functions make it suitable for applications in difficult environments. It operates on the Microsoft® Windows® CE. NET Professional version 4.2 operating system. The 13.56 MHz RFID function and OsiSense XG RFID system software installed on the portable terminal allow maintenance operations to be performed on the electronic tags and compact smart antennas.

Transfer of data to a PC is made via an RS-232 communication port.

The portable terminal **XGSTP401** comprises a:

- 1 CF (Compact Flash) format expansion connector
- 2 Color touchscreen
- 3 Keypad (45 keys)
- 4 RS-232 port

The following accessories are included with the terminal:

- PC connecting cable
- OsiSense XG RFID system software (installed)
- battery, universal battery charger, 3 styluses, protective cover
- user guide

#### Field expander

Field expanders are accessories designed to operate with the XG RFID smart antennas. They allow you to adapt the shape of the dialog field of the XGCS4901201 smart antennas to conveying/handling applications. The concept is a connection-free induction link between the smart antenna and the field expander. Two standard models are available:

- The conveyor model **XGFEC540** detects ISO 15693 tags on a narrow strip covering the width of the conveyor (mounted between two rollers of the conveyor)
  - Dimensions (mm): 400 x 23 x 50
  - Nominal sensing distance: 30–90 mm (1.18–3.54 in.) depending on the associated tag
- The universal model **XGFEC2525** increases the detection area and distance of ISO 15693 tags, which also permits higher passing speeds of the tags
  - Dimensions: 250 x 250 x 10
  - Nominal sensing distance: 26–150 mm (1.02–5.90 in.) depending on the associated tag
- Read/write compatibility with the majority of the 13.56 MHz/ISO 15693 tags on the market

(NOTE: These accessories are not compatible with ISO 14443 tags)

(1) For smart antenna and tag selection according to passing speeds, see page 13.



Electronic tags

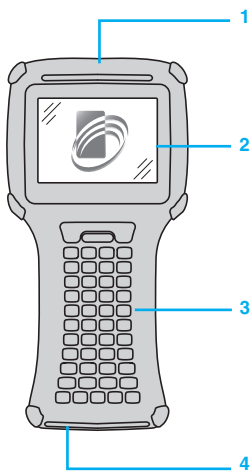

Portable diagnostics terminal



Field expanders

# OsiSense™ XG

## Radio Frequency Identification System

### 13.56 MHz

#### XG RFID connection boxes

Three types of quick connection boxes are available:

- Ethernet box **XGSZ33ETH** for an Ethernet Modbus TCP/IP network
- Tap-off box **TCSAMT31FP** for a Modbus or Uni-Telway communication bus
- Profibus box **XGSZ33PDP** for a Profibus-DP network
- Ethernet/IP box **XGSZ33EIP** for an Ethernet/IP network

#### Ethernet box XGSZ33ETH

The XG RFID Ethernet box **XGSZ33ETH** allows you to connect XGCS smart antennas to an Ethernet network (Modbus TCP/IP protocol).

It provides PLC or PC access to the following functions of XGCS smart antennas:

- reading/writing of tags
- control and checking
- monitoring
- diagnostics

The **XGSZ33ETH** Ethernet box is fitted with M12 connectors. It is used to connect the power supply, the Ethernet network, and 1–3 XGCS smart antennas.

It comprises a sealed metal enclosure fitted with the following:

- 1 Power On and Ethernet signaling LEDs
- 2 One Ethernet socket, M12 type, D coding
- 3 One power supply socket, M12 type, 4-pin male
- 4 3 sockets, M12 type female, A coding, for connecting 1–3 XGCS smart antennas.

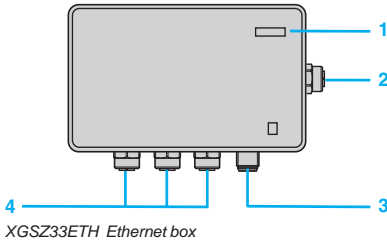

XGSZ33ETH Ethernet box

#### Tap-off box TCSAMT31FP

The XG RFID tap-off box **TCSAMT31FP** allows you to connect XGCS smart antennas to a Modbus or Uni-Telway communication bus.

The **TCSAMT31FP** tap-off box is fitted with M12 connectors. It is used to connect the supply, the Modbus communication bus, and 1–3 XGCS smart antennas.

It comprises a sealed metal enclosure fitted with the following:

- 1 One green LED indicator: Power On
- 2 One network output socket, M12 type 5-pin female, A coding
- 3 One network input socket, M12 type 5-pin male, A coding
- 4 One power supply socket, M12 type 4-pin male, A coding
- 5 3 sockets, M12 type female, A coding, for connecting 1–3 compact XGCS smart antennas

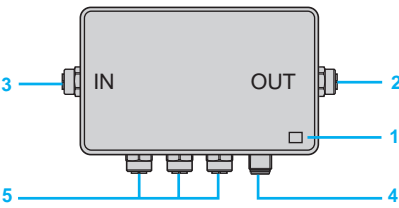

TCSAMT31FP tap-off box

#### Profibus box XGSZ33PDP

The XG RFID Profibus box **XGSZ33PDP** allows you to connect XGCS smart antennas to a Profibus-DP network.

It provides PLC or PC access to the functions of XGCS smart antennas:

- reading/writing of tags
- control and checking
- monitoring
- diagnostics

The **XGSZ33PDP** Profibus box is fitted with M12 connectors. It is used to connect the power supply, the Profibus-DP network, and 1–3 XGCS smart antennas.

It comprises a sealed metal enclosure fitted with the following:

- 1 Two coding wheels for configuration of the network address
- 2 One Profibus network input socket, M12 type 5-pin male, B coding
- 3 3 sockets, M12 type female, A coding, for connecting 1–3 XGCS smart antennas
- 4 One power supply socket, M12 type 4-pin male, A coding
- 5 One configuration port, M12 type female, A coding
- 6 Profibus network, Modbus network, and connection box status signaling LEDs
- 7 One Profibus network output socket, M12 type 5-pin female, B coding.

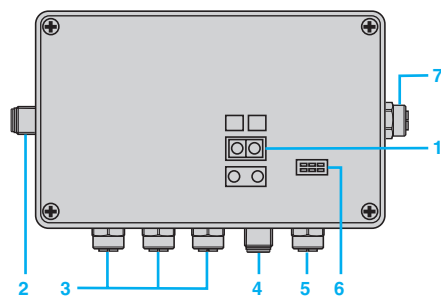

XGSZ33PDP Profibus box

#### Ethernet/IP box XGSZ33EIP

The XG RFID Ethernet/IP box **XGSZ33EIP** lets you to connect a group of XGCS smart antennas as a node on an Ethernet/IP network.

It allows the PLC or PC to access these functions of the XGCS smart antennas:

- reading/writing of tags
- control and checking
- monitoring
- diagnostics

The **XGSZ33EIP** Ethernet/IP box is fitted with M12 connectors. It is used to connect the power supply, the Profibus-DP network, and 1–3 XGCS smart antennas.

It comprises a sealed metal enclosure fitted with the following:

- 1 Ethernet connector, M12 4-pin female, D-coding
- 2 Three sockets, M12 5-pin female, A-coding, for connecting OsiSense XG compact smart antennas
- 3 Power supply connector, M12 4-pin male, A-coding
- 4 Configuration port, M12 female, A-coding (for Schneider Electric use only)
- 5 Signaling LEDs for the status of the Ethernet fieldbus, Modbus, and splitter box

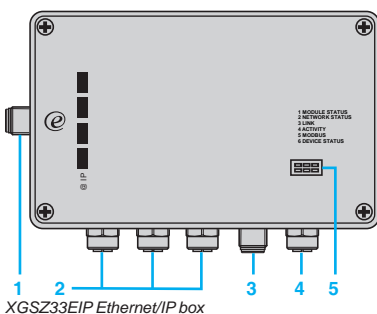

XGSZ33EIP Ethernet/IP box

#### Mounting example for Modbus™ network

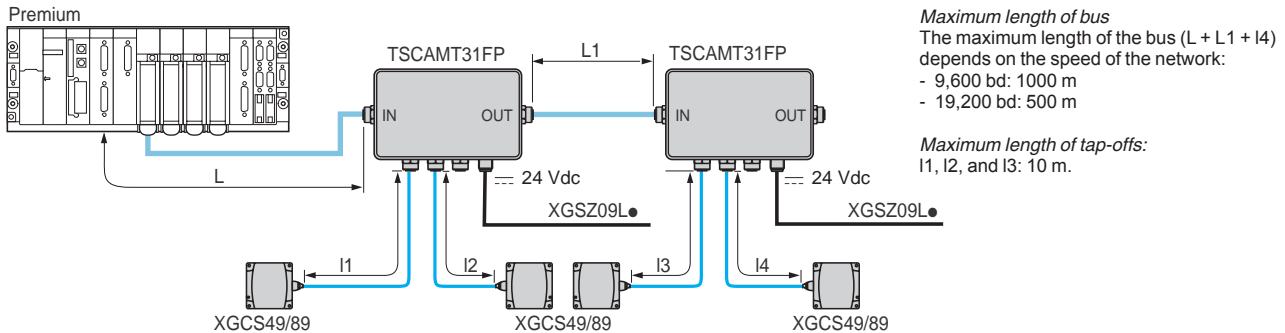

#### Example of connection to a Schneider Electric PLC

##### Direct connection

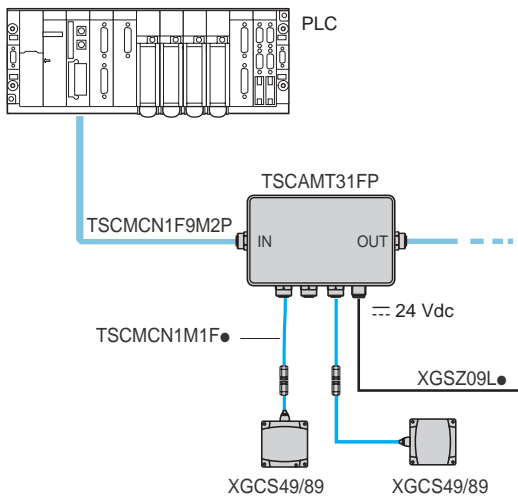

##### Connection via a TSXSCA62

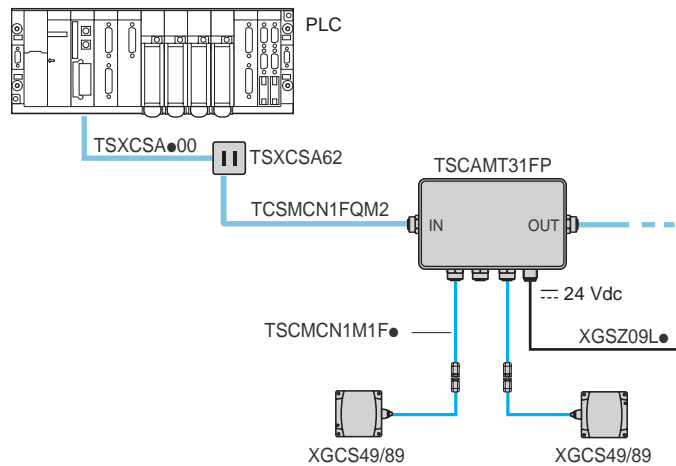

#### Example of a connection on an Ethernet Modbus™ TCP/IP network

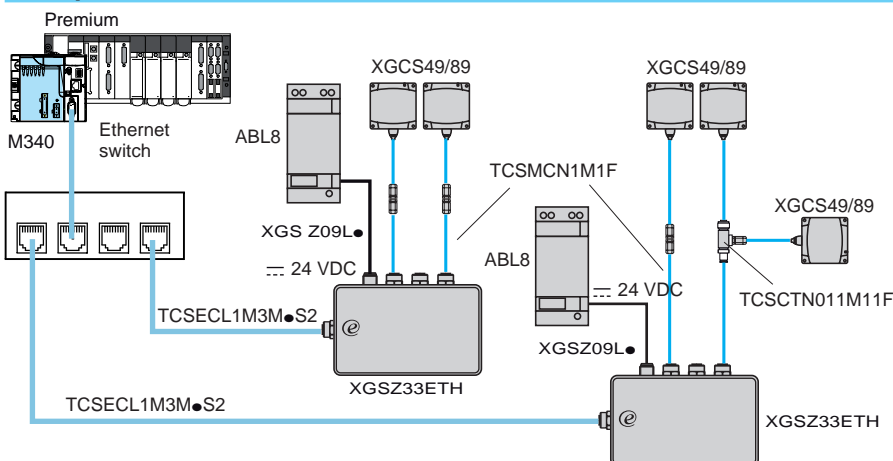

The number of smart antennas connected to each box can be increased by using the M12 T-connector (catalog number TCSECL1M3M.S2). To maintain high-performance operation, we recommend that a maximum of 8 compact smart antennas be connected (the Ethernet box has eight communication ports and sockets that can be simultaneously open on TCP/IP). In cases where the I/O scanning function is used (which requires an additional communication port), do not connect more than seven smart antennas. The total length of the smart antenna side network for XGCS smart antennas (XGCS49 and XGCS89) is limited to 160 m (525 ft).

#### Example of a mixed IP 20 and IP 67 connection on an Ethernet Modbus™ TCP/IP network

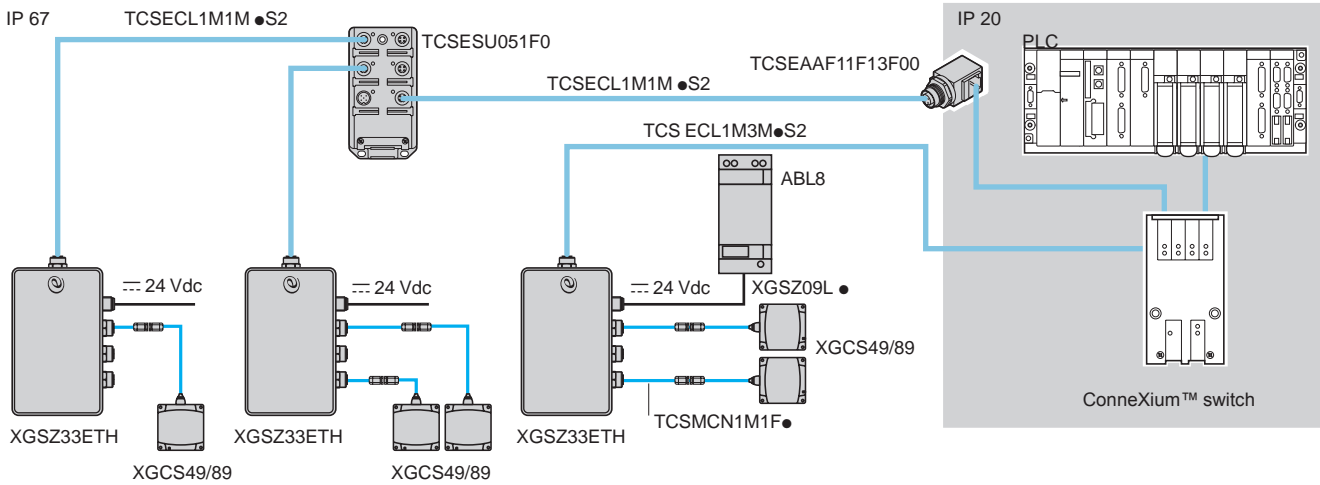

#### Example of a connection to a Magelis™ terminal

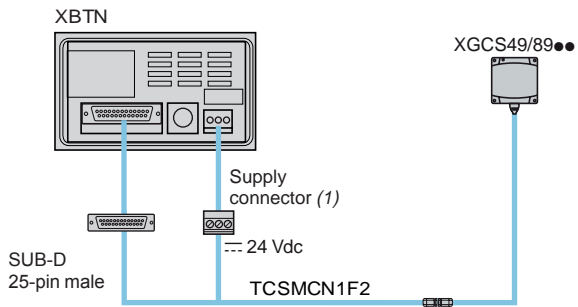

Cable TCSMCN1F2 connections

Scheme	Contact	Signal	Wire color
	1	Drain (Modbus-SHLD)	—
	2	24 Vdc	Red
	3	0 V Modbus-GND	Black
	4	D0	White
	5	D1	Blue

1) Magelis™ terminal supply connector (included with the Magelis terminal).

#### Example of a connection on an Ethernet/IP network

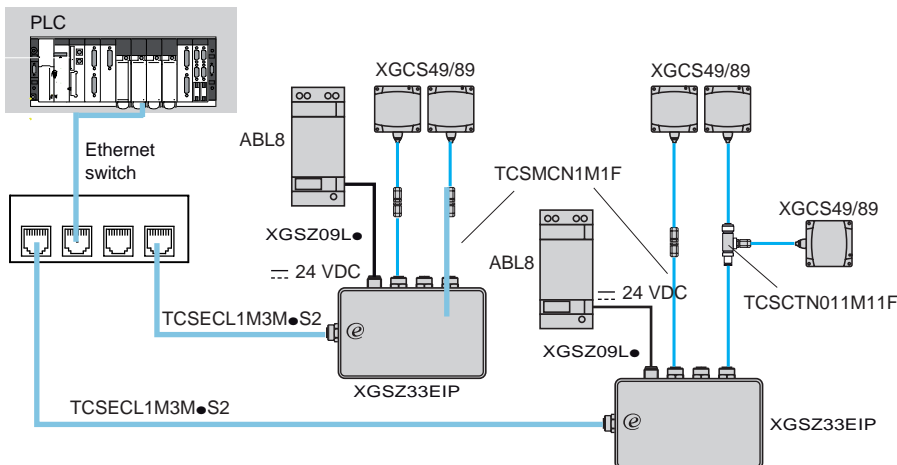

The number of smart antennas connected to each box can be increased by using the M12 T-connector (catalog number TCSCTN011M11F). To maintain high-performance operation, we recommend that a maximum of 8 compact smart antennas be connected. The total length of a smart antenna side network for XGCS smart antennas (XGCS49 and XGC89) is limited to 160 m (525 ft).

#### Example of an architecture in a Profibus network

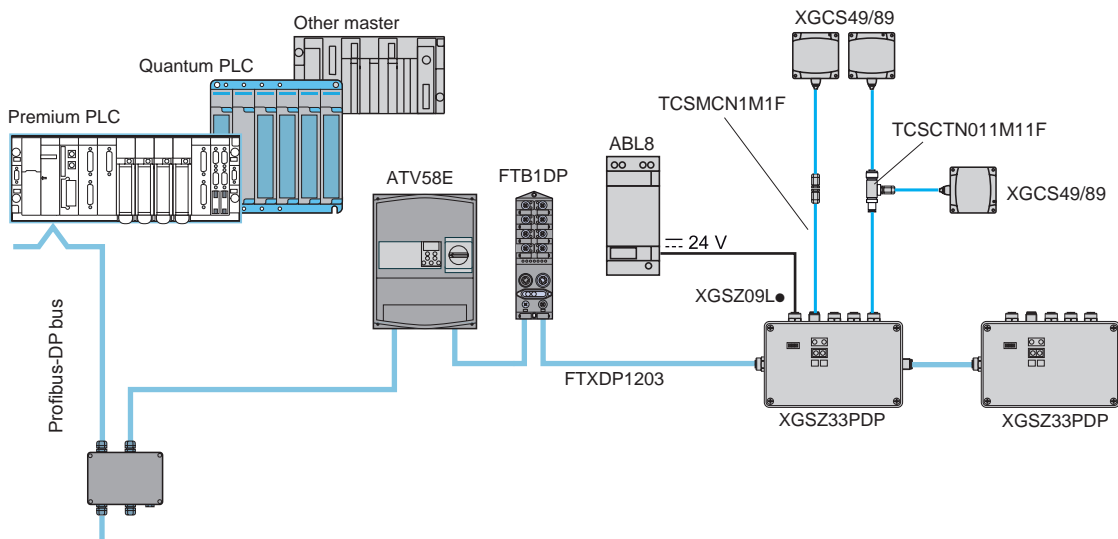

#### Example of a connection on a Twido™ PLC

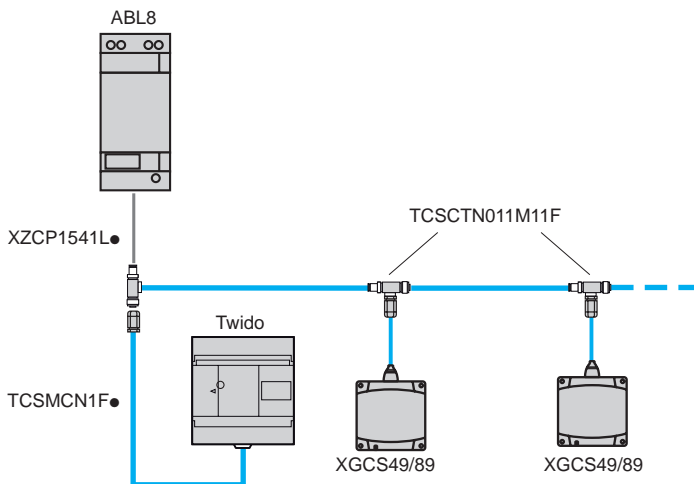

#### Example of a connection to a PC

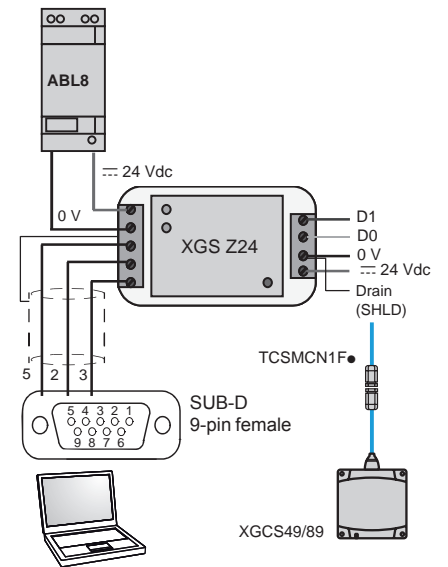

#### Power supply cable connections

XZCP1541L●				Power supply ABL8	
Scheme	Contact	Signal	Wire color	Terminal	
	1	NC	Brown	—	
	2	24 Vdc	White	24 Vdc	
	3	0 V GND	Blue	0 V GND	
	4	NC	Black	—	

#### TCSMCN1F● cable connections

TCSMCN1F●				Twido™ PLC	
Scheme	Contact	Signal	Wire color	Terminal	Scheme
	1	Drain (SHLD)	—	—	
	2	24 Vdc	Red	—	
	3	0 V GND	Black	SG	
	4	D0	White	B	
	5	D1	Blue	A	

The compact smart antennas can be directly connected to the Modbus port of a PLC. Up to 15 compact smart antennas can be linked to the RS-485 port using T-connectors. (In cases where the length of the network exceeds 100 m / 328 ft, fit a line terminator, catalog no. FTXCNTL12.) This cabling system is specific to the OsiSense XG RFID System (powered network). No other Modbus slave equipment can be connected to it.

# OsiSense™ XG

## Radio Frequency Identification System

### 13.56 MHz

#### Specifications of XG RFID compact smart antennas

Smart antenna type			XGCS4901201	XGCS8901201
<b>Certifications</b>			UL, FCC part 15c	
<b>Conformity to standards</b>			CE, EN 301489-1, EN 301489-3, ETS 300330-1 and ETS 300330-2	
<b>Ambient air temperature</b>	For operation	°C (°F)	-25 to +70 (-13 to +158)	
	For storage	°C (°F)	-40 to +85 (-40 to +185)	
<b>Degree of protection</b>	Conforming to IEC 60529		IP 67	
<b>Vibration resistance</b>	Conforming to EN 60068.2.27		2 mm from 5–29.5 Hz / 7 gn from 29.5–150 Hz	
<b>Shock resistance</b>	Conforming to EN 60068.2.6		30 g/11 ms	
	Conforming to EN 50102		Degree IK 02	
<b>Resistance to interference</b>	Conforming to IEC 61000		Resistance to electrostatic discharge, radiated electromagnetic fields, fast transients, electrical surges, conducted and induced interference and network frequency magnetic fields.	
<b>Dimensions, W x H x D</b>		mm	Flat form 40: 40 x 40 x 15	Flat form 80: 80 x 80 x 26
<b>RFID frequency</b>		MHz	13.56	
<b>Type of associated tag</b>			ISO 15693 and ISO 14443 standard tags. Automatic detection of the type of tag	
<b>Compatible RFID microchip examples</b>			Texas (Tag-it HFI); Philips (SL2, SL1, Ultralight, Std 1K/2K, Desfire; STM (CRIX4K); INSIDE (micropass)	
<b>Nominal sensing distance</b>	Depending on associated tag	mm (in.)	18–70 (0.71–2.76)	20–100 (0.79–3.94)
<b>Nominal supply voltage</b>		Vdc	--- 24 PELV (Protective Extra Low Voltage)	
<b>Supply voltage limits (including ripple)</b>		Vdc	--- 19.2–29	
<b>Consumption</b>		mA	< 60	
<b>Serial links</b>	Type		RS-485	
	Protocol		Modbus RTU or Uni-Telway	
	Speed	Bd	9,600–115,200 (automatic detection)	
<b>Display</b>			1 dual color LED for the communication network: Modbus/Uni-Telway 1 dual color LED for the RFID communication (Presence of tag / Smart antenna/tag dialog)	
<b>Connections</b>			M12, 5-pin male, shielded connector. Only for connection to the communication network and the supply.	
<b>Tightening torque</b>	Screws	Nm	< 1	< 3

#### Specifications of portable 13.56 MHz RFID diagnostics terminal

<b>Conformity to standards</b>			CE, FCC class A, Part 15225	
<b>Ambient air temperature</b>	For operation	°C (°F)	0 to +50 (32 to +122)	
	For storage	°C (°F)	-25 to +55 (-13 to +131)	
<b>Relative humidity</b>		RH	5–95% without condensation	
<b>Degree of protection</b>			IP 65	
<b>Supply voltage</b>			7.2 V NiMH type rechargeable battery (included with terminal) External: --- 11-18 Vdc	
<b>Operating time</b>			4 hours continuous operation (tag dialog)	
<b>Operating system</b>			Microsoft Windows CE.NET Professional version 4.2	
<b>Processor</b>			Intel Xscale® PXA255 CPU, 400 MHz	
<b>Memory</b>	RAM		SDRAM 64 Mb (16 Mb reserved for operating system)	
	Storage		Internal compact Flash: 512 Mb standard + Slot for compact Flash card (such as memory, wi-fi, Ethernet, or Bluetooth)	
<b>Display</b>	Screen		Color touchscreen: 72 mm x 54 mm, QVGA TFT	
	Resolution		320 x 240 pixels	
<b>Keypad</b>			45 booted keys	
<b>Signaling</b>			5 LEDs + 1 charging LED	

# OsiSense™ XG

## Radio Frequency Identification System

### 13.56 MHz

Specifications of XG RFID connection boxes			
Connection box type		Tap-off box TCSAMT31FP	Ethernet box XGSZ33ETH
Certifications		UL	
Conformity to standards		CE	
Ambient air temperature	For operation	°C (°F)	-25 to +55 (-13 to +131)   0 to +70 (32 to +158)
	For storage	°C (°F)	-40 to +85 (-40 to +185)   -40 to +85 (-40 to +185)
Relative humidity		RH	30 to 95% without condensation
Degree of protection		IP 65	
Supply voltage		Vdc	--- 24 PELV (limits 19.2–29 V), M12, 4-pin male, A coding, connector
Consumption (connection box only)		W	–   < 1
Smart antenna connection		M12 5-pin female, A coding, connector	
Electromagnetic interference	Conforming to IEC 61000	Level 3	
	Conforming to EN 55022	Class B	
LED display		Power on (green)	- Ethernet network activity (RUN, green) - Collision detection (COL, red) - Diagnostics (STS, yellow) - Error (Err, red) - Power on (green)
Transparent Ready™ Services	Class	–	A10
	Basic Web server	–	IP configuration address
	Basic communication service	–	Modbus messaging (reading/writing of words: 1 to 123 words per request)
Connection	Physical interface	–	10 BASE-T/100BASE-TX
	Transfer rate	–	10/100 Mbps
	Medium	–	Ethernet cable with M12 connection

Specifications of XG RFID electronic tags								
Tag Type		XGHB444345	XGHB445345	XGHB90E340	XGHB320345	XGHB221346	XGHB211345	
Ambient air temperature	For operation	°C (°F)	-25 to +70 (-13 to +158)	-25 to +50 (13 to +122)	-25 to +70 (-13 to +158)			
	For storage	°C (°F)	-40 to +85 (-40 to +185)	-40 to +55 (-40 to +131)	-40 to +85 (-40 to +185)			
Degree of protection		IP 68		IP 65	IP 68			
Standard supported		ISO 14443		ISO 15693				
Vibration resistance		Conforming to EN 60068.2.27   2 mm from 5 to 29.5 Hz / 7 gn from 29.5 to 150 Hz						
Shock resistance		Conforming to EN 60068.2.6   30 g/11 ms						
		Conforming to EN 50102   Degree IK 02						
Dimensions		mm	40 x 40 x 15	40 x 40 x 15	54 x 85.5 x 1	Ø 30 x 3	26 x 26 x 13   M18 x 1 x 12	
Housing material		PBT		PVC	PVC	PBT	PBT	
Mounting method		Screw or clip		–	Screw	Screw or clip	Screw in	
Memory capacity		bytes	3,408	13,632	256	112	256	
Type of memory		EEPROM						
Type of operation		Read/Write						
Type of associated smart antenna		XGCS●●●●●●●●						
Nominal sensing distance (Read/Write)	With smart antenna XGCS49	mm (in.)	33 (1.30)	30 (1.18)	70 (2.76)	48 (1.89)	40 (1.57)	18 (0.71)
	With smart antenna XGCS89		48 (1.89)	40 (1.57)	100 (3.94)	65 (2.56)	55 (2.17)	20 (0.79)
	With smart antenna XGCS49011201 + field expander XGFEC540		–	–	90 (3.54)	42 (1.65)	–	–
	With smart antenna XGCS49011201 + field expander XGFEC2525		–	–	150 (5.91)	80 (3.15)	42 (1.65)	–
Number of read cycles		Unlimited						
Number of write cycles		Minimum   100,000 per data bit throughout the temperature range At 30 °C (86 °F)   2.5 million (typical value)						
Read time		ms	9.25 + 0.375 x n (1)	16.25 + 0.375 x n (1)	12 + 0.825 x n (1)			
Write time		ms	13 + 0.8 x n (1)	20 + 0.8 x n (1)	20 + 11.8 x n (1)	12 + 5.6 x n (1)	20 + 11.8 x n (1)   19 + 4.1 x n (1)	
Data retention time		10 years						
Mounting on metal support		Yes (2)		No		Yes (2)   No		

(1) n = number of 16-bit words.  
(2) Installation information: see page 32.

# OsiSense™ XG

## Radio Frequency Identification System

### 13.56 MHz

#### Specifications of XG RFID connection boxes

Connection box type		Profibus box XGSZ33PDP	Ethernet IP box XGSZ33EIP
<b>Certifications</b>		UL	
<b>Conformity to standards</b>		CE	
<b>Ambient air temperature</b>	For operation	°C (°F) 0 to +55 (32 to +131)	0 to +55 (32 to +131)
	For storage	°C (°F) -25 to +85 (-40 to +185)	-25 to +85 (-13 to +185)
<b>Relative humidity</b>		RH 30 to 95% without condensation	
<b>Degree of protection</b>		IP 65	
<b>Supply voltage</b>		Vdc --- 24 PELV (limits 21.6–26.4 V). M12, 4-pin male, A coding, connector	
<b>Consumption (connection box only)</b>		W < 2.5	< 2.5
<b>Smart antenna connection</b>		M12 5-pin female, A coding	M12 5-pin female, A coding
<b>Electromagnetic interference</b>	Conforming to IEC 61000	Level 3	
	Conforming to EN 55022	Class B	
<b>LED display</b>		- Profibus network activity (RUN, green) - Profibus network activity (OFF, red) - Communications bus (Error, flashing red) - Modbus (RUN, green) - Gateway configuration (green)	- Power on (green) - Network status (Ethernet/IP, green) - Link (Connected, green) - Activity (Receive/transmit, green) - Subnet status (Running, green) - Device Status (Running/initializing, green)
<b>Transparent Ready™ Services</b>	Class	-	A10
	Basic Web server	-	IP configuration address
	Basic communication service	Reading/writing of words	
<b>Connection</b>	Physical interface	-	10 BASE-T/100BASE-TX
	Transfer rate	9.6–12,000 Kbd: automatic detection of speed	10/100 Mbps
	Medium	RS-485 twisted pair	Ethernet cable with M12 connection

#### Specifications of XG RFID electronic tags

Tag Type		XGHB320246	XGHB440245	XGHB440845	XGHB443245	XGHB411346
<b>Ambient air temperature</b>	For operation	°C (°F) -25 to +85 (-13 to +185)	-25 to +70 (-13 to +158)		-25 to +90 (-13 to +194)	
	For storage	°C (°F) -40 to +85 (-40 to +185)	-40 to +85 (-40 to +185)		-25 to +120 (-13 to +248) +160 (+320) for 50 hours +220 (+428) maximum peak temperature	
<b>Degree of protection</b>		IP 65	IP 68			
<b>Standard supported</b>		ISO 15693		ISO 14443B	ISO 15693	
<b>Vibration resistance</b>	Conforming to EN 60068.2.27	2 mm from 5 to 29.5 Hz / 7 gn from 29.5 to 150 Hz				
<b>Shock resistance</b>	Conforming to EN 60068.2.6	30 g/11 ms				
	Conforming to EN 50102	Degree IK 02				
<b>Dimensions</b>	mm	Ø 30 x 3	40 x 40 x 15		Ø 40 x 11	
<b>Housing material</b>		PBT	PBT		PPS	
<b>Mounting method (2)</b>		Screw	Screw or clip		Screw	
<b>Memory capacity</b>	bytes	2,000	2,000	8,192	32,768	64 + serial number (8 bytes)
<b>Type of memory</b>		FeRAM				EEPROM
<b>Type of operation</b>		Read/Write				
<b>Type of associated smart antenna</b>		XGCS●●●●●●●●				
<b>Nominal sensing distance (Read/Write)</b>	With smart antenna XGCS49	mm (in.) 45 (1.77)	45 (1.77)	25 (0.98)	30–39 (1.18–1.54)	
	With smart antenna XGCS89	65 (2.55)	65 (2.55)	39 (1.53)	35–46 (1.38–1.81)	
	With smart antenna XGCS49011201 + field expander XGFEC540	50 (1.96)	50 (1.96)	-	-	-
	With smart antenna XGCS49011201 + field expander XGFEC2525	40 (1.57)	40 (1.57)	-	-	-
<b>Number of read cycles</b>		10 billion				(3)
<b>Number of write cycles</b>	At 30 °C (86 °F)	10 billion				(3)
<b>Max. speed XGCS49●●</b>	Read a serial number	2.1	2.1	2.3	2.3	
	Read a word (2)	1.5	1.5	1.8	1.8	
	Read or write 10 words (2)	0.6	0.6	1.7	1.7	
<b>Max. speed XGCS89●●</b>	Read a serial number	3.5	3.5	3.8	3.8	
	Read a word (2)	2.5	2.5	2.9	2.9	
	Read or write 10 words (2)	1	1	2.7	2.7	
<b>Read time (1)</b>	ms	7+ 2 x n		6 + 0.25 x n		12 + 0.825 x n
<b>Write time (1)</b>	ms	7+ 2.4 x n		6 + 0.25 x n		20 + 11.8 x n
<b>Data retention time</b>		10 years				
<b>Mounting on metal support</b>		No	Yes			

(1) n = number of 16-bit words. (2) Installation notes: see page 32.

(3) The lifetime of the tags is closely linked to the temperature conditions. To validate the compatibility of this tag with the requirements of each application, conduct preliminary tests with samples in real conditions.

New

# OsiSense™ XG

## Radio Frequency Identification System

### 13.56 MHz



XGCS4901201



XGHB44345



XGHB90E340



XGHB221346



XGHB211345



XGHB411346



XGHB320345



TCSAMT31FP

- (1) Configuration badge XGSZCNF01 included with smart antenna—installation guide must be ordered separately (catalog number DIA4ED3051001).
- (2) Metal mounted: 30 mm (1.18 in.) with XGCS49●; 45 mm (1.77 in.) with XGCS89●.
- (3) Metal mounted: 20 mm (0.78 in.) with XGCS49●; 28 mm (1.10 in.) with XGCS89●.
- (4) Customized versions on request.
- (5) Download GSD configuration file (SE100BBB.gsd) from [www.Schneider-Electric.com](http://www.Schneider-Electric.com) (Products and services/Automation and control/Detection/RFID).

#### Compact smart antennas, 13.56 MHz

Description	Protocols	Dimensions mm	Catalog number	Weight kg (lb)
Compact smart antenna <b>Flat form 40 (1)</b> M12 male connector on flying lead	Modbus RTU and Uni-Telway	40 x 40 x 15	<b>XGCS4901201</b>	0.057 (0.126)
Compact smart antenna <b>Flat form 80 (1)</b> M12 male connector on flying lead	Modbus RTU and Uni-Telway	80 x 80 x 26	<b>XGCS8901201</b>	0.257 (0.567)

#### Electronic tags

Tag type	Nominal sensing dist. XGCS49● XGCS89●	Dimensions mm	Sold in lots of	Unit catalog number	Weight kg (lb)
<b>Flat form 40</b> 3000 bytes EEPROM	33 mm (1.30 in.) 48 mm (1.89 in.)	40 x 40 x 15	—	<b>XGHB444345</b>	0.031 (0.068)
<b>Flat form 40</b> 13,000 bytes EEPROM	30 mm (1.80 in.) 40 mm (1.57 in.)	40 x 40 x 15	—	<b>XGHB445345</b>	0.031 (0.068)
<b>Flat form 40 (2)</b> 2000 bytes FeRAM	45 mm (1.77 in.) 65 mm (2.56 in.)	40 x 40 x 15	—	<b>XGHB440245</b>	0.031 (0.068)
<b>Flat form 40 (3)</b> 8000 bytes FeRAM	25 mm (0.98 in.) 39 mm (1.54 in.)	40 x 40 x 15	—	<b>XGHB440845</b>	0.031 (0.068)
<b>Flat form 40 (3)</b> 32,000 bytes FeRAM	25 mm (0.98 in.) 39 mm (1.54 in.)	40 x 40 x 15	—	<b>XGHB443245</b>	0.031 (0.068)
<b>ISO badge (4)</b> 256 bytes EEPROM	70 mm (2.76 in.) 100 mm (3.94 in.)	54 x 85.5 x 1	<b>10</b>	<b>XGHB90E340</b>	0.005 (0.011)
<b>Disc</b> 112 bytes EEPROM	48 mm (1.89 in.) 65 mm (2.56 in.)	∅ 30 x 3	<b>5</b>	<b>XGHB320345</b>	0.005 (0.011)
<b>Disc</b> 2000 bytes FeRAM	45 mm (1.77 in.) 65 mm (2.56 in.)	∅ 30 x 3	<b>5</b>	<b>XGHB320246</b>	0.005 (0.011)
<b>Flat form 26</b> 256 bytes EEPROM	40 mm (1.57 in.) 55 mm (2.17 in.)	26 x 26 x 13	<b>1</b>	<b>XGHB221346</b>	0.025 (0.055)
<b>Cylindrical</b> 256 bytes EEPROM	18 mm (0.71 in.) 20 mm (0.79 in.)	M18 x 1 x 12	<b>5</b>	<b>XGHB211345</b>	0.020 (0.044)
<b>Cylindrical</b> 64 bytes EEPROM	30–39 mm (1.18–1.54 in.) 35–46 mm (1.38–1.81 in.)	M40 x 11	—	<b>XGHB411346</b>	0.025 (0.055)

#### Connection boxes

Description	For use with	Supply voltage	Catalog number	Weight kg (lb)
<b>Ethernet box 3-channel</b> Integrated Ethernet port (10/100 Mbps) Modbus TCP/IP protocol Class A10	Compact smart antennas XGCS49● and XGCS89●	— 24 Vdc	<b>XGSZ33ETH</b>	1.060 (2.337)
<b>Tap-off box 3-channel</b> Modbus and Uni-Telway	Compact smart antennas XGCS49● and XGCS89●	— 24 Vdc	<b>TCSAMT31FP</b>	1.060 (2.337)
<b>Profibus box 3-channel</b> Profibus-DP protocol (5)	Compact smart antennas XGCS49● and XGCS89●	— 24 Vdc	<b>XGSZ33PDP</b>	1.060 (2.337)
<b>Ethernet/IP box 3-channel</b> Integrated Ethernet port (10/100 Mbps)	Compact smart antennas XGCS49● and XGCS89●	— 24 Vdc	<b>XGSZ33EIP</b>	1.060 (2.337)

# OsiSense™ XG

## Radio Frequency Identification System

### 13.56 MHz



XGFEC540



XGFEC2525

#### Field expanders (3)

Description	Nominal sensing distance	For use with	Catalog number	Weight kg (lb)
<b>Conveying type field expander</b> Dimensions (mm) 400 x 23 x 50 (1)	30–90 mm (1.18–3.54 in.) depending on tag used (only ISO 15693)	Smart antenna XGCS4901201 Tags XGHB90E340 XGHB320345 XGHB221346	<b>XGFEC540</b>	0.640 (1.411)
<b>Conveying type field expander</b> Dimensions (mm) 200 x 23 x 50 (1)	30–90 mm (1.18–3.54 in.) depending on tag used (only ISO 15693)	Smart antenna XGCS4901201 Tags XGHB90E340 XGHB320345 XGHB221346	<b>XGFEC520</b>	0.640 (1.411)
<b>Universal type field expander</b> Dimensions (mm) 250 x 250 x 10 (1)	26–150 mm (1.02–5.91 in.) depending on tag used (only ISO 15693)	Smart antenna XGCS4901201 Tags XGHB90E340 XGHB320345	<b>XGFEC2525</b>	0.565 (1.466)



XGSTP401



XGSTP41BA

#### Terminal and accessories

Description	Application	Catalog number	Weight kg (lb)
<b>Portable 13.56 MHz RFID diagnostics terminal (2)</b>	Read/write operations on electronic tags and diagnostics on compact smart antennas Operating system: Microsoft Windows CE.NET Professional version 4.2	<b>XGSTP401</b>	0.943 (2.079)
<b>Battery pack charger</b>	Portable terminal	<b>XGSTP41CH</b>	0.675 (1.488)
<b>Battery, 7.2 V NiMH</b>	Portable terminal	<b>XGSTP41BA</b>	0.168 (0.370)
<b>Compact Flash memory expansion</b>	Portable terminal Capacity = 128 Mb	<b>XBTZGM128</b>	0.050 (0.110)



XGSZCNF01

#### Configuration badge (replacement)

Description	Application	Catalog number	Weight kg (lb)
<b>Badge</b>	Configuration of smart antenna addresses	<b>XGSZCNF01</b>	0.005 (0.011)

#### Documentation

Description	Catalog number	Weight kg (lb)
<b>XG RFID compact smart antennas guide</b>	<b>DIA4ED3051001</b>	0.130 (0.029)

(1) For other dimensions, please consult your local sales office.

(2) Includes OsiSense XG RFID system software (installed), universal battery charger, PC connecting cable, 3 styluses, protective cover, battery, and user guide.

(3) For custom shape field expanders, contact the Customer Care Center at 1-800-435-2121.

# OsiSense™ XG

## Radio Frequency Identification System

### 13.56 MHz



TCSMCN1FQM2



TCSMCN1F9M2P

#### Modbus™ network connection accessories

Description	Application	Length m	Catalog number	Weight kg (lbs)
Modbus shielded connecting cable, black, IP 67 M12 connectors, male/female, A coding (1)	RS-485 connection between a compact smart antenna and a tap-off box TCSAMT31FP or between 2 tap-off boxes	1	TCSMCN1M1F1	0.080 (0.176)
		2	TCSMCN1M1F2	0.115 (0.254)
		5	TCSMCN1M1F5	0.270 (0.595)
		10	TCSMCN1M1F10	0.520 (1.146)
Modbus shielded pre-wired M12 connector, IP 67, female/bare wires, A coding (1)	Connection between tap-off box TCSAMT31FP and Modbus/ Uni-Telway network (TSXSCA50)	2	TCSMCN1F2	0.115 (0.254)
		5	TCSMCN1F5	0.270 (0.595)
		10	TCSMCN1F10	0.520 (1.146)
<b>Modbus shielded connecting cable, black, M12/SUB-D15, A coding</b>	Connection between tap-off box TCSAMT31FP and Modbus/Uni-Telway network (TSXSCA62)	2	TCSMCN1FQM2	0.270 (0.595)
<b>Modbus shielded connecting cable, black, M12/Mini-DIN 8-way, A coding</b>	Modbus connection between tap-off box TCSAMT31FP and a PLC (such as Twido™)	2	TCSMCN1F9M2P	0.350 (0.772)
<b>Modbus SL serial link cable</b> (Shielded dual twisted pair RS-485 main cables)	Modbus SL serial link	100	TSXCSA100	5.680 (12.522)
		200	TSXCSA200	10.920 (24.074)
		500	TSXCSA500	30.000 (66.139)

#### Ethernet connection accessories

##### Ethernet connection accessories for IP 67 switch

Description	End fittings	Length m	Catalog number	Weight kg (lbs)
<b>Copper connecting cables, straight</b>	1 x IP 67 M12 4-pin connector and 1 x RJ45 connector	1	TCSEL1F3M12S2D	–
		3	TCSEL1F3M13S2D	–
		10	TCSEL1F3M110S2D	–
		25	TCSEL1F3M125S2D	–
		40	TCSEL1F3M140S2D	–
	2 x IP 67 M12 4-pin connectors	1	TCSEL1F1F12S2D	–
		3	TCSEL1F1F13S2D	–
		10	TCSEL1F1F110S2D	–
		25	TCSEL1F1F125S2D	–
		40	TCSEL1F1F140S2D	–
<b>M12 Ethernet switch IP 67, ConneXium™ (2)</b>	–	–	TCSESU051F0	0.210 (0.463)
<b>M12 female/RJ45 adapter</b>	Ethernet connection	–	TCSEAAF11F13F00	–

#### Do-It-Yourself Ethernet copper cable and connectors

The Do-It-Yourself ConneXium™ Ethernet system allows Ethernet copper connecting cables to be prepared on-site in the required length. The cables are intended for connection to the Ethernet 10/100 Mbps network. The maximum length of the connecting cables made in this way is 80 m. The cabling can be quickly assembled using a knife and ordinary wire cutters—no special tools required.

Description	Specifications	Length m	Catalog number	Weight kg (lbs)
<b>Ethernet copper cable</b> 2 x 24 AWG shielded dual twisted pairs	Conforms to applicable standards and approvals	300	TCSECN300R2	–
<b>RJ45 connector</b>	Conforms to EIA/TIA-568-D	–	TCSEK3MDS	–
<b>M12 connector</b>	Conforms to IEC 60176-2-101	–	TCSEK1MDRS	–

#### Power supplies

Description	Output voltage	Nominal power	Nominal current	Catalog number	Weight kg (lbs)
	Vdc	W	A		
<b>Regulated power supply 100/240 Vac</b>	24	7	0.3	ABL8MEM24003	0.180 (0.397)
	30	–	1.2	ABL8MEM24012	0.520 (1.146)

(1) Holder for identification legend included with product.

(2) Other ConneXium™ connection accessories: refer to [www.Schneider-Electric.com](http://www.Schneider-Electric.com).



ABL8MEM24003

#### Profibus-DP connection accessories

Description	Composition	Type	Length m	Catalog number	Weight kg (lb)
Connecting cable for connection between Profibus box XGSZ33DP and Profibus-DP network	Fitted with 2 x M12 5-pin connectors	Straight	0.3	FTXDP1203	0.040 (0.088)
			0.6	FTXDP1206	0.070 (0.154)
			1	FTXDP1210	0.100 (0.220)
			2	FTXDP1220	0.160 (0.353)
			3	FTXDP1230	0.220 (0.485)
		Elbowed	0.3	FTXDP3203	0.040 (0.088)
			0.6	FTXDP3206	0.070 (0.154)
			1	FTXDP3210	0.100 (0.220)
			2	FTXDP3220	0.160 (0.353)
			3	FTXDP3230	0.220 (0.485)
			5	FTXDP3250	0.430 (0.948)
M12 connector, 5-pin male, B coding			–	FTXDP12M5	0.050 (0.110)
M12 connector, 5-pin female, B coding			–	FTXDP12F5	0.050 (0.110)
Network terminator, M12 connector			–	FTXDPTL12	0.010 (0.022)
Cable without end fittings			100	TSXPBSCA100	–
			400	TSXPBSCA400	–

#### Other connection accessories

Description	Application	Length m	Catalog number	Weight kg (lbs)
Pre-wired M12 4-pin female supply connector, A coding (1)	24 V supply to connection boxes XGSZ33ETH and TCS AMT31FP	2	XGSZ09L2	0.115 (0.254)
		5	XGSZ09L5	0.270 (0.595)
		10	XGSZ09L10	0.520 (1.146)
M12 5-pin female, A coding, – connector		–	FTXCN12F5	0.050 (0.110)
M12, 5-pin male, A coding, – connector		–	FTXCN12M5	0.050 (0.110)
Network T connector, M12, 1 male/2 female 5-pin, A coding	RS-485 network	–	TCSCNT011M11F	0.035 (0.070)
Supply connector, screw terminals, M12 straight, A coding		–	XZCC12FDM40B	0.020 (0.044)
Protective cap (Sold in lots of 10)	M12 female connector	–	FTXCM12B	0.100 (0.220)
Network terminator, M12 male, 120 W		–	FTXCNTL12	0.010 (0.022)
Line adapter, RS-232C/RS-485, without modem signals. Supply: c 18–30 Vdc. Consumption: 20 mA. Maximum transmission speed: 19,200 bd. Mounting on 35 mm 7 rail.			XGSZ24	–

(1) Holder for the identification legend included with product.

#### Mounting accessories

Description	For use with	Catalog number	Weight kg (lbs)
Clip-on 90° mounting bracket	Flat form 40 smart antenna: XGCS4901201	XSZBC90	0.060 (0.132)
	Flat form 40 tags: XGHB44●345		
Clip-on mounting plate	Tags XGHB221346	XSZBE90	0.060 (0.132)
	Flat form 40 smart antenna: XGCS4901201	XSZBC00	0.025 (0.055)
	Flat form 40 tags: XGHB44●345		
Mounting plate	Tags XGHB221346	XSZBE00	0.025 (0.055)
3D Mounting kit (2)	Connection boxes TCSAMT31FP and XGSZ33ETH	XGSZ3P	0.195 (0.430)
	Field expander XGFEC2525		
	Support for M12 rod	XUZ2003	0.220 (0.485)
	M12 rod	XUZ2001	0.050 (0.110)
Ball-joint mounted mounting bracket		XUZ2003	0.220 (0.485)

(2) For a 3D mounting kit, order the following: rod support XUZ2003, M12 rod XUZ2001, and ball-joint mounting bracket XUZ2003.

#### Other accessories

Description	Sold in lots of	Catalog number	Weight kg (lbs)
Key for screwing in/unscrewing Ø18 mm cylindrical tag	5	XGSZ05	0.011 (0.024)
Identification legend for 23 x 4 mm connecting cables	200	XGSZ08MKW	0.056 (0.123)



TCSCNT011M11F



XGSZ3P

XUZ2001

XUZ2003

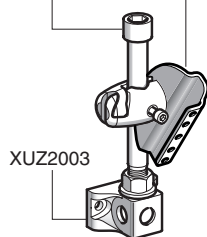

XUZ2003

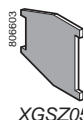

XGSZ05

## Compact smart antennas (mm)

XGCS4901201

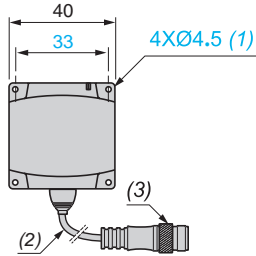
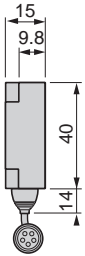

XGCS8901201

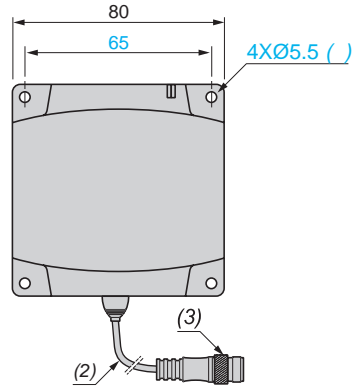
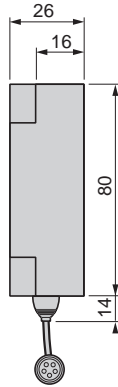

(1) For CHC type screws.

(2) Shielded cable (length: 20 cm).

(3) M12 5-pin male, A coding, connector.

## Read/write electronic tags (mm)

Square format tags

XGHB44•345

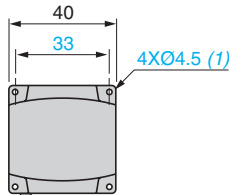
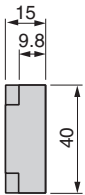

XGHB221346

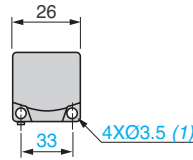
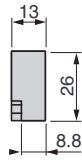

Rectangular format tags

XGHB90E340

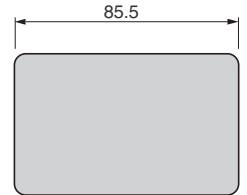

(1) For CHC type screws.

Cylindrical format tags

XGHB320345

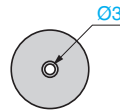
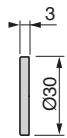

XGHB211345

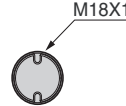

XGHB411346

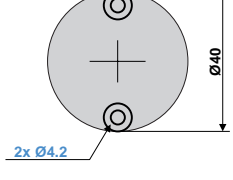
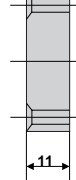

## Connection boxes (mm) (1)

Tap-off box TCSAMT31FP

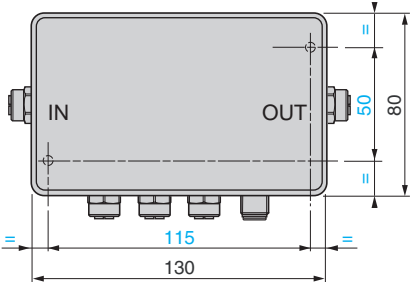

Ethernet box XGSZ33ETH

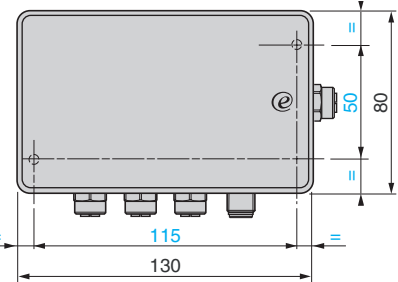

Profibus box XGSZ33PDP

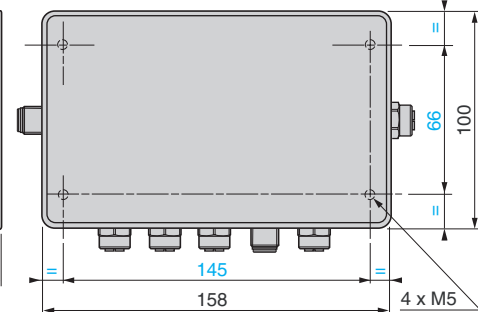

Ethernet IP splitter box XGSZ33EIP

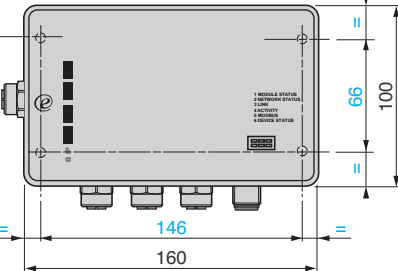

**Mounting plate XGSZ3P**

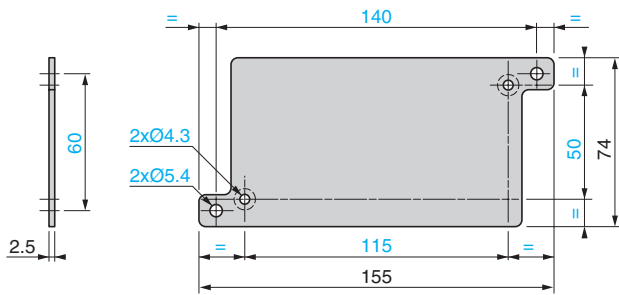

(1) Allow a 110 mm clearance zone for connecting the cables.

**Mounting brackets (mm)**

**XSZBC90**

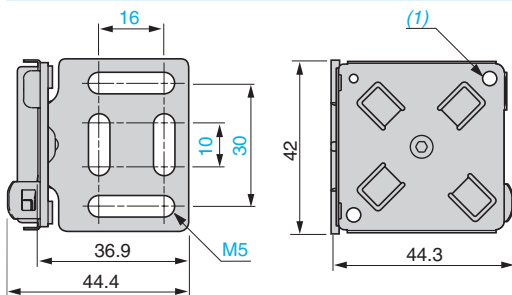

(1) Four M4 x 14 screws (included).

**Mounting plates (mm)**

**XSZBC00**

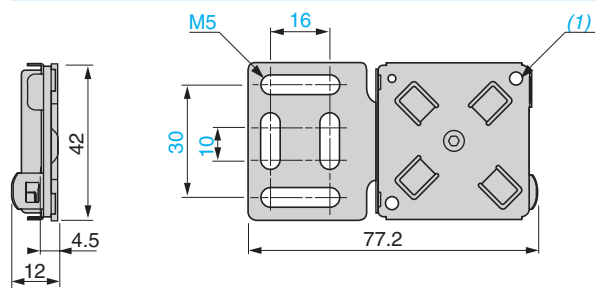

(1) Four M4 x 14 screws (included).

**XSZBE90**

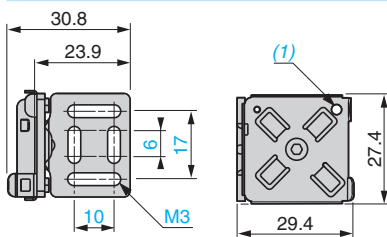

(1) Two M3 x 12 screws (included).

**XSZBE00**

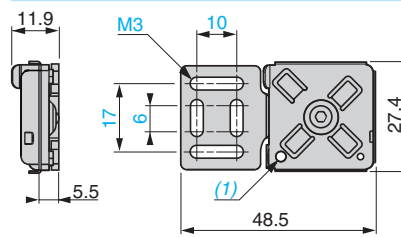

(1) Two M3 x 12 screws (included).

# OsiSense™ XG

Radio Frequency Identification System  
13.56 MHz

**Portable RFID diagnostics terminal (mm)**  
XGSTP401

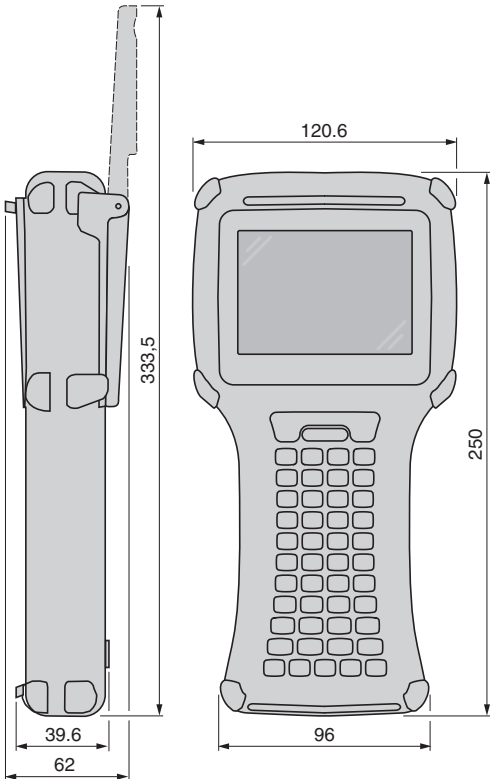

**Field expanders (mm)**  
Conveying type XGSEC540

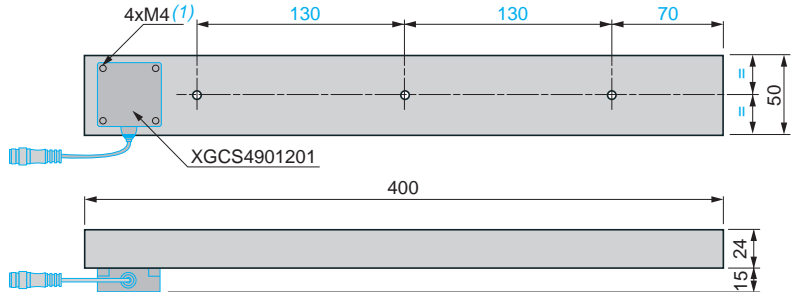

(1) Four M4 screws (included).

**Universal type XGSEC2525**

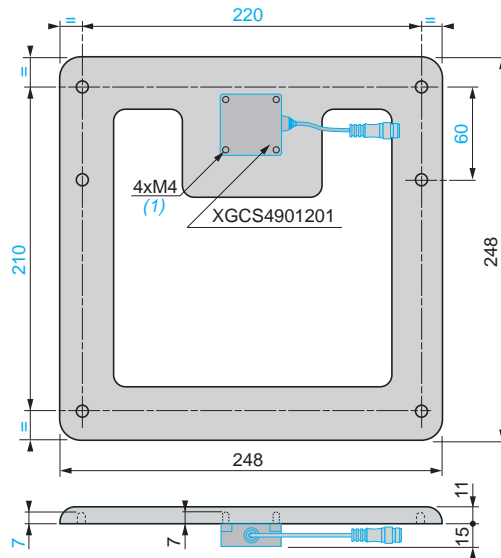

(1) Four M4 screws (included).

## Modbus connections

### Smart antennas XGCS●901201

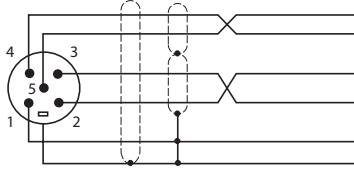

**Pin no.**

1
2
3
4
5

Connector casing

**Modbus smart antenna signal**

Drain (Modbus-SHLD)
+ 24 V ~
0 V / Modbus-GND
D0
D1
Shielding

### Connection box TCSAMT31FP

#### Socket to smart antenna cabling

Pin no.	Signal
1	–
2	Drain (Modbus-SHLD)
3	+ 24 V ~
4	0 V/Modbus-GND
5	D0
5	D1

#### Socket to power supply cabling

Pin no.	Signal
1	+ 24 V ~
2	+ 24 V ~
3	0 V ~
4	0 V ~

#### Socket to another connection box cabling

Pin no.	Signal
1	Drain (Modbus-SHLD)
2	–
3	0 V/Modbus-GND
4	D0
5	D1

#### Socket to industrial PLC cabling

Pin no.	Signal
1	Drain (Modbus-SHLD)
2	–
3	0 V/Modbus-GND
4	D0
5	D1

### Cable connections

#### TCSMCN1F●

Pin no.	Signal
1	–
2	Drain (Modbus-SHLD)
3	Red + 24 V ~
4	Black 0 V/Modbus-GND
5	White D0
5	Blue D1
Connector casing	Shielding

#### XGSZ09L

Pin no.	Signal
1	Red + 24 V ~
2	NC
3	Black 0 V ~
4	NC

**Ethernet and Modbus/TCP connection**

**Ethernet box XGSZ33ETH**

**Socket to smart antenna cabling**

Pin no.	Signal
1	Earth
2	+ 24 V $\overline{\text{---}}$
3	0 V
4	D0
5	D1



**Socket to power supply cabling**

Pin no.	Signal
1	+ 24 V $\overline{\text{---}}$
2	+ 24 V $\overline{\text{---}}$
3	0 V $\overline{\text{---}}$
4	0 V $\overline{\text{---}}$



**Cable TCSECL1M3M●●S2**

M12	Signal	Signal	RJ45
1	TD +	TD +	1
3	TD -	TD -	2
2	RD +	RD +	3
4	RD -	RD -	6

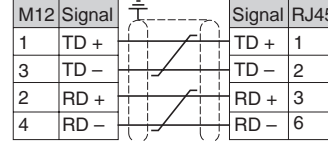

**Socket to Ethernet connection**

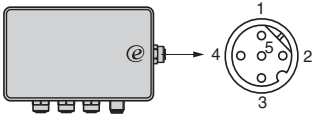

**EtherNet/IP connection**

**EtherNet/IP box: XGSZ33EIP**

**Socket to smart antenna cabling**

Pin no.	Signal
1	Earth
2	+ 24 V $\overline{\text{---}}$
3	0 V
4	D0
5	D1



**Socket to power supply cabling**

Pin no.	Signal
1	+ 24 V $\overline{\text{---}}$
2	+ 24 V $\overline{\text{---}}$
3	0 V $\overline{\text{---}}$
4	0 V $\overline{\text{---}}$



**Cable TCSECL1M3M●●S2**

M12	Signal	Signal	RJ45
1	TD +	TD +	1
3	TD -	TD -	2
2	RD +	RD +	3
4	RD -	RD -	6

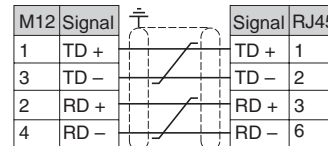

**PROFIBUS-DP connection**

**PROFIBUS-DP box: XGSZ33PDP**

**Socket to smart antenna cabling**

Pin no.	Signal
1	Earth
2	+ 24 V $\overline{\text{---}}$
3	0 V
4	D0
5	D1



**Socket to power supply cabling**

Pin no.	Signal
1	+ 24 V $\overline{\text{---}}$
2	+ 24 V $\overline{\text{---}}$
3	0 V
4	0 V



**PROFIBUS-DP network connections**

Input	Output	Pin no.	Signal	Description
		1	VP	Line terminator polarisation
		2	RxD/TxD-N	Receive/transmit data (-) (red wire)
		3	DGND	GND PROFIBUS
		4	RxD/TxD-P	Receive/transmit data (+) (green wire)
		5	Shielding	Shielding or earth
		Connector casing	Shielding	Shielding or earth

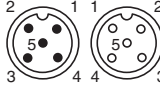

Dialogue zones of compact smart antennas

XGCS4901201

XGCS8901201

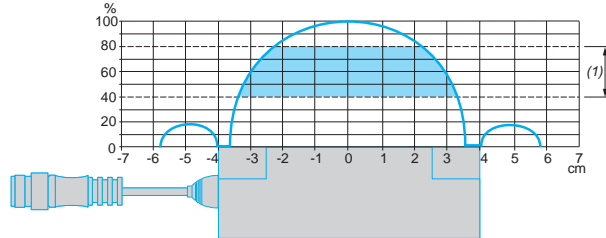
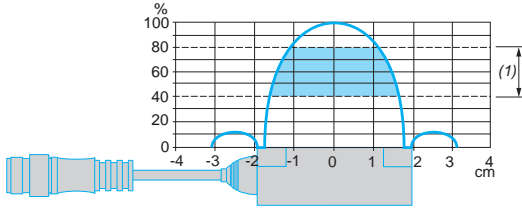

(1) Recommended crossing zone: between 0.4 and 0.8 Sn.

Dialogue zones for field expanders

XGFEC540 + XGHB90E340

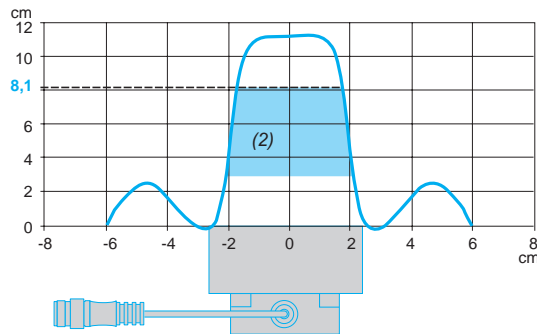
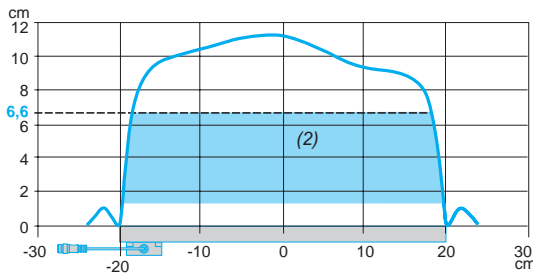

XGFEC540 + XGHB320345

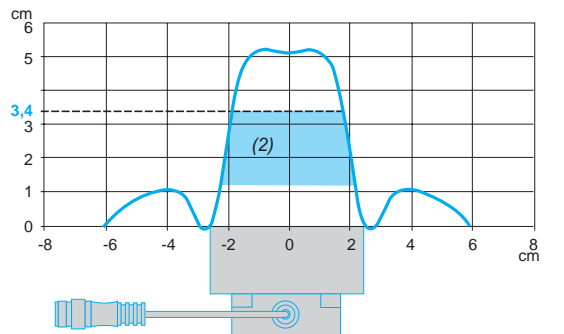
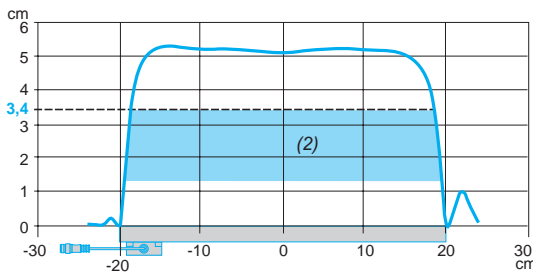

XGFEC2525 + tag XGHB90E340

XGFEC2525 + tag XGHB320345

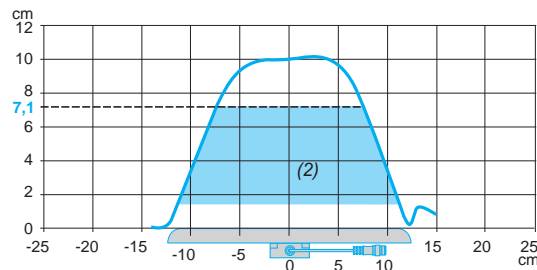
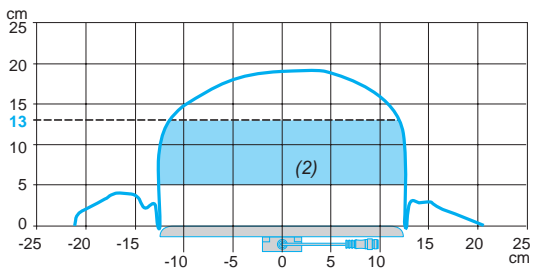

(2) Recommended working zone.

Angular positioning between smart antenna and tag

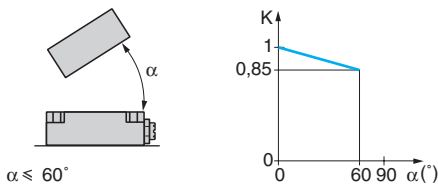

$K =$  correction coefficient to be applied to the nominal sensing distance. Read distance = nominal sensing distance  $\times K$ .

Minimum mounting distances between system components, mm (in.)

Distance between smart antennas

Minimum distance between 2 identical smart antennas according to their positioning and the type of tag used

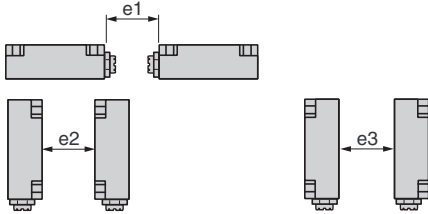

Tag	XGC 40 x 40 format			XGC 80 x 80 format		
	e1	e2	e3	e1	e2	e3
XGHB90E340	310 (12.2)	550 (21.7)	120 (4.7)	430 (16.9)	750 (29.5)	280 (11.0)
XGHB221346	200 (7.9)	320 (12.6)	100 (3.9)	280 (11.0)	530 (20.9)	260 (10.2)
XGHB320●●	140 (5.5)	360 (14.2)	110 (4.3)	310 (12.2)	540 (21.3)	240 (9.4)
XGHB211345	210 (8.3)	180 (7.1)	60 (2.4)	200 (7.9)	370 (14.6)	170 (6.7)
XGHB44●●●	90 (3.5)	190 (7.5)	30 (1.2)	310 (12.2)	400 (15.7)	160 (6.3)
XGHB123345	210 (8.3)	180 (7.1)	60 (2.4)	200 (7.9)	370 (14.6)	170 (6.7)

Distance between field expanders

Minimum distance between 2 identical field expanders according to their positioning and the type of tag used

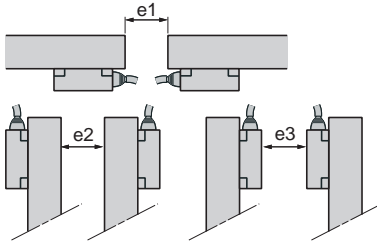

Tag	Field expander XGFEC540			Field expander XGFEC2525		
	e1	e2	e3	e1	e2	e3
XGHB90E340	195 (7.7)	285 (11.2)	195 (7.7)	570 (22.4)	890 (35.0)	960 (37.8)
XGHB320345	420 (16.5)	540 (21.3)	450 (17.7)	720 (28.3)	1275 (50.2)	1200 (47.2)

Distance between tags

Minimum distance between 2 identical tags according to their positioning and the type of smart antenna used

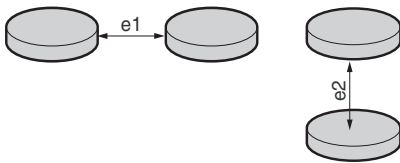

Tag	XGC 40 x 40 format		XGC 80 x 80 format	
	e1	e2	e1	e2
XGHB90E340	35 (1.4)	60 (2.4)	110 (4.3)	140 (5.5)
XGHB221346	50 (2.0)	10 (0.4)	120 (4.7)	50 (2.0)
XGHB320345	70 (2.8)	50 (2.0)	190 (7.5)	60 (2.4)
XGHB211345	40 (1.6)	10 (0.4)	120 (4.7)	20 (0.8)
XGHB444345	20 (0.8)	10 (0.4)	70 (2.8)	40 (1.6)
XGHB445345	10 (0.4)	10 (0.4)	60 (2.4)	10 (0.4)
XGHB440845	30 (1.2)	10 (0.4)	60 (2.4)	10 (0.4)
XGHB443245	30 (1.2)	10 (0.4)	60 (2.4)	10 (0.4)

Minimum permissible mounting distances in a metal structure, mm (in.)

Smart antennas and tags

Smart antennas XGCS49/S89 and Tags XGHB221346/ XGHB44●●

Tag XGHB32●●

Tags XGHB90E340, XGHB211345

No metal parts within 15 mm of the tag.

No metal parts within 25 mm (1.0 in.) of the tag.

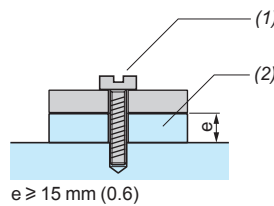
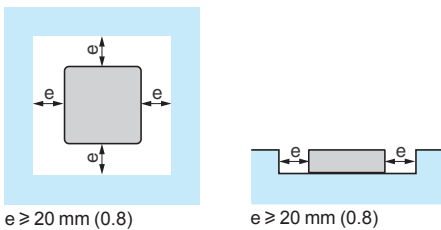

(1) Tightening torque ≤ 1 N·m (8.9 lb-in)  
(2) Insulating material

Tags	Nominal sensing distance Sn, mm (in.)	
	XGCS49	XGCS89
XGHB90E340	70 (2.8)	100 (3.9)
XGHB221346	40 (1.6)	55 (2.2)
XGHB320345	48 (1.9)	65 (2.6)
XGHB211345	18 (0.7)	20 (0.8)
XGHB123345	18 (0.7)	20 (0.8)
XGHB444345	33 (1.3)	48 (1.9)
XGHB445345	30 (1.2)	40 (1.6)
XGHB440245	45 (1.8)	65 (2.6)
XGHB440845	25 (1.0)	39 (1.5)
XGHB443245	25 (1.0)	39 (1.5)

Reduced sensing distance with presence of metal, mm (in.)

XGCS49	XGCS89
30 (1.2)	33 (1.3)
45 (1.8)	56 (2.2)
16 (0.6)	15 (0.6)
16 (0.6)	15 (0.6)
28 (1.1)	34 (1.3)
24 (0.9)	28 (1.1)
30 (1.2)	45 (1.8)
20 (0.8)	28 (1.1)
20 (0.8)	28 (1.1)

Field expanders

	e, mm (in.)	h, mm (in.)
XGFEC540	15 (0.6)	30 (1.2)
XGFEC2525	0 (0.0)	75 (3.0)

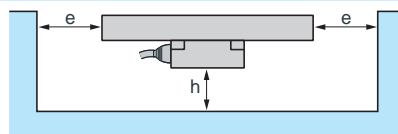

# OsiSense™ XG

Radio frequency identification  
13.56 MHz

---