

# Calibration technology



Part of your business

## Contents

<b>WIKA product lines</b>	<b>3</b>
<b>Everything at a glance</b>	<b>4</b>
<b>Pressure</b>	<b>6</b>
<b>Temperature</b>	<b>14</b>
<b>Current, voltage, resistance</b>	<b>18</b>
<b>Accessories</b>	<b>19</b>
<b>Calibration systems</b>	<b>20</b>
<b>Technical information</b>	<b>21</b>
<b>Calibration services</b>	<b>26</b>
<b>WIKA worldwide</b>	<b>28</b>



**Fully automatic production of measuring instruments**



**The modern high-bay warehouse ensures efficient logistics**

# Ability to meet any challenge

## Our knowledge for your success

In the course of the last six decades the name WIKA has become a symbol for sophisticated solutions in the field of pressure and temperature measurement.

Our ever increasing ability is the basis for implementation of innovative technologies in the form of reliable products and efficient system solutions.

We owe our leading position in the world market to the consistent dedication towards premium quality, to which, today, 7,300 employees of the WIKA group of companies are committed. More than 500 experienced sales staff ensure that our customers are individually and competently advised and looked after from the outset. Anywhere and any time.

## Certified quality

The WIKA quality assurance management system has been certified in accordance with ISO 9001 since 1994. The quality and safety standards of our company meet the standard systems of several countries.

## Made by WIKA

The development and high-tech production in our owned modern production facilities (Germany, Brazil, China, India, Canada, Poland, Switzerland, South Africa and USA) is the best warranty for our flexibility.

Whether SMD automatic insertion machines, CNC automatic machining centres, welding robots, laser welding, sputterers, thermotransfer printing or thin film production - we exploit all possibilities to achieve above-average results. And the end result: More than 43 million quality products are delivered year in, year out, in more than 100 countries. Worldwide, approximately 350 million WIKA measuring instruments are in use.



**DKD/DAkkS accredited calibration laboratories for pressure and temperature**

# WIKA product lines

The WIKA programme covers the following product lines for various fields of application.

## Electronic pressure measurement

WIKA offers a complete range of electronic pressure measuring instruments: pressure sensors, pressure switches, pressure transmitters and process transmitters for the measurement of gauge, absolute and differential pressure. Our pressure measuring instruments are available in the measuring ranges 0 ... 0.6 mbar to 0 ... 15,000 bar. These instruments come supplied with standardised current or voltage output signals also intrinsically safe per ATEX or with flameproof enclosure, interfaces and protocols for various field buses. Whether ceramic thick film, metal thin film or piezo-resistive, WIKA is the leading manufacturer worldwide that develops and produces the full range of today's leading sensor technologies.

## Mechatronic pressure measurement

As a result of the almost unlimited options for different combinations of mechanical and electrical connections, an extraordinary range of instrument variants is possible. Various digital and analogue output signals are also available for these measuring instruments.

For our measuring instruments we use latest sensors, tested in automotive applications millions of times over. They work without any kind of mechanical contact, consequently they are wear-resistant, and there's absolutely no influence on the mechanics.

## Mechanical pressure measurement

Indicating instruments for gauge, absolute and differential pressure with Bourdon tube, diaphragm or capsule pressure element have been tested millions of times over. These instruments cover scale ranges from 0 ... 0.5 mbar to 0 ... 7,000 bar and accuracies of up to 0.1 %.

## Diaphragm seals

WIKA diaphragm seals, fitted with pressure gauges, pressure transducers, pressure transmitters etc., are recognised and valued internationally for the most difficult of measuring tasks. The measuring instruments can thus be used at extreme temperatures -90 ... +400 °C and aggressive, corrosive, heterogeneous, abrasive, highly viscous or toxic media. The optimal diaphragm seal designs, materials and filling media are available for each application.

## Electrical temperature measurement

Our range of products includes thermocouples, resistance thermometers also with on-site display, temperature switches as well as analogue and digital temperature transmitters for all industrial applications, covering measuring ranges from -200 ... +1,600 °C.

## Mechatronic temperature measurement

As a result of the integration of switch contacts and output signals into our mechanical temperature measuring instruments, we can offer a wide variety of combined instruments. With switch contacts the pointer position triggers a change-over. Electrical output signals are realised via an additional, independent sensor circuit resistance thermometer or thermocouple.

## Mechanical temperature measurement

The mechanical temperature measuring instruments work on the bimetal, expansion or gas actuation principle and cover scale ranges from -200 ... +700 °C. All thermometers are suited for operation in a thermowell as required.

## Level measurement

WIKA has a comprehensive range of level measuring instruments available for temperatures up to 450 °C, specific gravity from 400 kg/m<sup>3</sup> and pressure ranges up to 420 bar. This includes standard instruments and customised products.

## Calibration technology

WIKA offers a broad product spectrum of calibration instruments for the physical measured values of pressure and temperature, and for electrical measured values. A multitude of specific patents ensure unmatched performance characteristics with many of our calibration instruments. The range of services comprises the calibration of pressure and temperature measuring instruments in our accredited DKD/DAkkS calibration laboratories and a mobile service to calibrate your instruments on site.

# From individual components ...

WIKA is the ideal partner for solutions in calibration technology, whether only a single service instrument is required quickly on site, or whether a fully automated calibration system needs to be designed for the laboratory or production. We are able to offer an appropriate solution for each application.

In relation to the measuring task and the measurement parameters, the following product matrix will assist you in finding the appropriate instrument within this product review.



## Portable pressure generation

Test pumps serve as pressure generators for the testing of mechanical and electronic pressure measuring instruments through comparative measurements. These pressure tests can be carried out statically in the laboratory or workshop, or on site at the measuring point.

Page 6



## Measuring components

High-precision pressure sensors and very stable standard thermometers are ideal for applications as references in industrial laboratories. Due to their analogue or digital interfaces they can be connected to existing evaluation instruments.

Page 9

Page 14



## Hand-helds, calibrators

Our hand-held measuring instruments (process tools) offer a simple capability for measurement or simulation of all established measurement parameters on site. They can be operated with a wide variety of pressure sensors or thermometers.

Page 7

Page 15

Page 18

- Pressure
- Temperature
- Current, voltage, resistance

# ... to a fully automated system

In the past few years WIKA has successfully integrated three renowned manufacturers of calibration equipment into the Group.

Mensor is known in the market for its outstanding portfolio of pressure controllers and consolidates WIKA's position as the market leader in the worldwide calibration market.

DH-Budenberg's product range includes high-end primary pressure standards and transfer standards of the Desgranges & Huot brand as well as laboratory and industrial standards of the Budenberg brand.



## Digital indicating precision measuring instruments

High-accuracy digital precision measuring instruments are ideal for application as reference standards in industrial laboratories, enabling high-accuracy calibration. They feature exceptionally simple handling and an extensive range of functionality.

Page 9

## Digital precision instruments and controllers

Due to their integrated controller, these instruments offer exceptional convenience. Typically, a fully automated setting of the required value can be set via the interface.

Page 9

Page 17

Page 18

## Fully automatic calibration systems as integrated solutions

Fully automated calibration systems are customer-specific, turnkey installations which can be fitted in laboratories as well as in the production environment. With integrated reference instruments and calibration software, calibration certificates can be generated and archived in a simple and reproducible way.

Page 20

Page 20

- Pressure
- Temperature
- Current, voltage, resistance

# Portable pressure generation

## Simple manual pressure generation

Test pumps serve as pressure generators for the testing, adjustment and calibration of mechanical and electronic pressure measuring instruments through comparative measurements.

These pressure tests can be carried out statically in the laboratory or workshop, or on site at the measuring point.

### CPP7

#### Pneumatic hand test pump



Measuring range: -850 mbar ... +7 bar  
 Medium: Ambient air  
 Special feature:
 

- Pressure and vacuum generation switchable
- Low weight
- Compact dimensions

 Data sheet: CT 91.04

### CPP30

#### Pneumatic hand test pump



Measuring range: -950 mbar ... +35 bar  
 Medium: Ambient air  
 Special feature:
 

- Pressure and vacuum generation switchable
- Compact dimensions

 Data sheet: CT 91.06

### CPP700-H, CPP1000-H

#### Hydraulic hand test pump

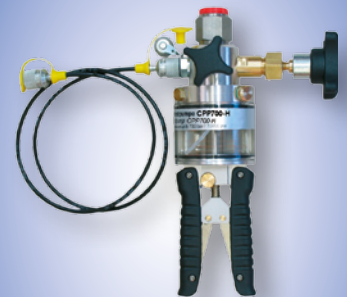

Measuring range: 0 ... 700 or 0 ... 1,000 bar  
 Medium: Oil or water  
 Special feature:
 

- Integrated medium reservoir
- Ergonomic handling

 Data sheet: CT 91.07

### CPP1000-M, CPP1000-L

#### Hydraulic hand spindle pump

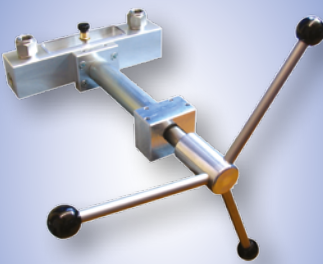

Measuring range: 0 ... 1,000 bar  
 Medium: Oil or water  
 Special feature:
 

- Smooth-running internal precision spindle
- Compact dimensions

 Data sheet: CT 91.05

### CPPxx00-X

#### Hydraulic comparison test pump

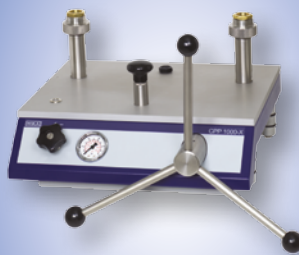

Measuring range: 0 ... 1,000 to 0 ... 7,000 bar  
 Medium: Oil or water  
 Special feature:
 

- Integrated reservoir and initial pressure pump
- Robust laboratory version

 Data sheet: CT 91.05 and CT 91.08

# Hand-helds, calibrators

## Portable calibration instruments for mobile use for the accurate measurement and recording of pressure profiles

For these portable hand-held measuring instruments, exchangeable pressure sensors are available with measuring ranges up to 6,000 bar.

Thus they are particularly suitable as test instruments for process technology, machine building, etc. Data recorded in the instrument can be evaluated via PC software.

### CPT2500

#### USB pressure transmitter



Measuring range:	0 ... 0.1 to 0 ... 1,000 bar
Accuracy:	0.2 %, 0.1 % (optional)
Medium:	Non-corrosive gases, liquids
Special feature:	<ul style="list-style-type: none"> <li>■ Recording interval adjustable from 1 ms ... 10 s</li> <li>■ No external voltage supply required</li> <li>■ Data storage and evaluation directly via PC</li> </ul>
Data sheet:	CT 05.01

### CPH6200

#### Hand-held pressure indicator



Measuring range:	0 ... 0.1 to 0 ... 1,000 bar
Accuracy:	0.2 %, 0.1 % (optional)
Medium:	Non-corrosive gases, liquids
Special feature:	<ul style="list-style-type: none"> <li>■ Integrated data logger</li> <li>■ Differential pressure measurement (optional)</li> </ul>
Data sheet:	CT 11.01

### CPH6300

#### Hand-held pressure indicator



Measuring range:	0 ... 0.1 to 0 ... 1,000 bar
Accuracy:	0.2 %, 0.1 % (optional)
Medium:	Non-corrosive gases, liquids
Special feature:	<ul style="list-style-type: none"> <li>■ Robust and waterproof case with IP 65, IP 67</li> <li>■ Integrated data logger</li> <li>■ Differential pressure measurement (optional)</li> </ul>
Data sheet:	CT 12.01

### CPH6400

#### Precision hand-held pressure indicator



Measuring range:	0 ... 0.4 to 0 ... 6,000 bar
Accuracy:	0.025 %
Medium:	Non-corrosive gases, liquids
Special feature:	<ul style="list-style-type: none"> <li>■ Integrated data logger</li> <li>■ Temperature measurement (optional)</li> </ul>
Data sheet:	CT 14.01

### Complete test and service cases

These cases can be assembled exactly to your requirements. Thus you will be fully equipped on site!



# Hand-helds, calibrators

Calibrations can be documented directly in the calibrator and later read on a PC. Optionally, a calibration certificate can be generated through software.

## CPH6510

Hand-held pressure calibrator,  
intrinsically safe



Measuring range:	0 ... 0.025 to 0 ... 700 bar
Accuracy:	Up to 0.025 %
Medium:	Non-corrosive gases, liquids
Special feature:	<ul style="list-style-type: none"> <li>■ Temperature measurement (optional)</li> <li>■ Differential pressure measurement (optional)</li> </ul>
Data sheet:	CT 14.51

## CPH6000

ProcessCalibrator



Measuring range:	0 ... 0.25 to 0 ... 6,000 bar
Accuracy:	0.025 %
Medium:	Non-corrosive gases, liquids
Special feature:	<ul style="list-style-type: none"> <li>■ Function of calibration</li> <li>■ Pressure switch test</li> </ul>
Data sheet:	CT 15.01

## CPH6600

Hand-held pressure calibrator with  
integrated pump



Measuring range:	0 ... 2 to 0 ... 20 bar
Accuracy:	0.025 %
Medium:	Clean, dry, non-corrosive gases
Special feature:	<ul style="list-style-type: none"> <li>■ Integrated electric pressure generation</li> <li>■ Temperature measurement (optional)</li> <li>■ Pressure switch test</li> </ul>
Data sheet:	CT 16.01

## CPH7600

Wally Box III



Measuring range:	-0.8 ... +20 bar
Accuracy:	0.025 %
Medium:	Clean, dry, non-corrosive gases
Special feature:	<ul style="list-style-type: none"> <li>■ Integrated electric pressure generation</li> <li>■ Pressure supply via external compressed air line</li> <li>■ Robust case design, IP 67</li> </ul>
Data sheet:	CT 17.01

## Pascal100

Hand-held multifunction calibrator



Measuring range:	0 ... 1,000 bar
Accuracy:	0.025 %
Medium:	Non-corrosive gases, liquids
Special feature:	<ul style="list-style-type: none"> <li>■ Integrated pressure generation</li> <li>■ Large display with touch-screen</li> <li>■ Measurement and simulation of pressure, temperature, current, voltage, resistance, frequency</li> </ul>
Data sheet:	CT 18.02

# Precision pressure measuring instruments

**Electrical measuring systems which convert pressure into an electrical signal and optionally visualise it**

Due to the low, DKD/DAkkS-certified measurement uncertainty of down to 0.008 % of the entire measuring chain, these instruments find their primary applications as a factory/working standard for testing and/or calibrating a variety of pressure measuring instruments.

## CPG500

### Digital pressure gauge



Measuring range:	-1 ... +20 bis 0 ... 1,000 bar
Accuracy:	0.25 %
Medium:	Non-corrosive gases, liquids
Special feature:	<ul style="list-style-type: none"> <li>■ Simple operation using 4 buttons</li> <li>■ Robust case with protective rubber cap, IP 67</li> </ul>
Data sheet:	CT 09.01

## CPG1000

### Precision digital pressure gauge



Measuring range:	0 ... 0.07 to 0 ... 700 bar
Accuracy:	0.05 %
Medium:	Non-corrosive gases, liquids
Special feature:	<ul style="list-style-type: none"> <li>■ Integrated data logger</li> <li>■ Robust case with protective rubber cap, IP 65</li> </ul>
Data sheet:	CT 10.01

## CPT61x0

### Precision pressure sensor

mentor



Measuring range:	0 ... 0.025 to 0 ... 400 bar
Accuracy:	0.01 %
Special feature:	<ul style="list-style-type: none"> <li>■ RS-232 or RS-485 connection</li> <li>■ Analogue output (optional)</li> </ul>
Data sheet:	CT 25.10

## CPG2500

### Precision pressure indicator, 1- or 2-channel version

mentor



Measuring range:	0 ... 0.025 to 0 ... 700 bar
Accuracy:	0.01 %
Medium:	Non-corrosive gases, > 1 bar liquids
Special feature:	<ul style="list-style-type: none"> <li>■ Up to 2 sensors</li> <li>■ Barometric reference (optional)</li> </ul>
Data sheet:	CT 25.02

# Pressure controllers

**Electronic controllers which quickly and automatically provide a pressure based on a supply pressure**

Due to the high accuracy and control stability, these types of instruments are especially suitable as references for production lines and laboratories, in order to carry out automatic testing and/or calibration of all types of sensors.

**An air data test set is an electronic controller which, based on a supply pressure, provides a pressure at a variable and adjustable rate.**

Air data test sets are specifically developed to convert the pressure to be controlled into a height or rate of climb and velocity.

As a result of the high accuracy, control stability and ability to simulate altitude and velocity, an air data test set is particularly suitable as a reference for aircraft workshops and also for instrument manufacturers and calibration laboratories in the aviation industry, in order to make calibrations on sensors and displays.

## CPC2000

Low-pressure version

mentor



Measuring range: 0 ... 1 to 0 ... 1,000 mbar  
 Accuracy: 0.1/0.3 % (for 0 ... 1 mbar)  
 Medium: Ambient air  
 Special feature: Integrated pressure generation  
 Data sheet: CT 27.51

## CPC3000

High-speed version

mentor



Measuring range: 0 ... 0.35 to 0 ... 70 bar  
 Accuracy: 0.025 %  
 Medium: Dry clean air or nitrogen  
 Special feature: Fast control speed  
 Data sheet: CT 27.55

## CPA8001

Air data test set

mentor



Measuring range: up to 3.4 bar abs.  
 Accuracy: 0.009 %  
 Medium: Dry, clean air or nitrogen  
 Special feature:
 

- Excellent control stability, even with rate control
- Overshoot-free control

 Data sheet: CT 29.01

## CPC6000

Standard version

mentor



Measuring range: 0 ... 0.025 to 0 ... 100 bar  
 Accuracy: 0.01 %  
 Medium: Dry clean air or nitrogen  
 Special feature:
 

- Up to 2 control/measuring channels with 2 sensors each
- Sensors exchangeable

 Data sheet: CT 27.61

## CPC8000

Precision version

mentor



Measuring range: 0 ... 0.025 to 0 ... 400 bar  
 Accuracy: 0.01 ... 0.008 %  
 Medium: Dry clean air or nitrogen  
 Special feature:
 

- Excellent control stability
- Overshoot-free control

 Data sheet: CT 28.01

## CPC8000-H

High-pressure version

mentor



Measuring range: 0 ... 600 to 0 ... 1,600 bar  
 Accuracy: 0.01 %  
 Medium: Hydraulic oil or water  
 Special feature: High stability, also for large volumes  
 Data sheet: CT 28.05

# Pressure balances, industrial series

**Compact and powerful primary standards with excellent running characteristics, based on the physical principle of Pressure = Force/Area**

The direct measurement of the pressure ( $p = F/A$ ), as well as the use of high-quality materials enable this small measurement uncertainty, in conjunction with an excellent long-term stability (recommended recalibration cycle of five years in accordance with the German Calibration Service DKD/DAkks).

Through the selection of a dual-range piston-cylinder system with automatic measuring range switching, this measurement uncertainty can be ensured, even with a single measuring system, over a large pressure range.

## CPB3800

### Compact version



Measuring range:	1 ... 120 to 10 ... 1,200 bar
Accuracy:	0.05 ... 0.025 %
Medium:	Special oil
Special feature:	<ul style="list-style-type: none"> <li>■ Compact dimensions and low weight</li> <li>■ Instrument base can also be combined with the CPB5800 piston-cylinder system</li> </ul>
Data sheet:	CT 31.06

## CPB5000

### Pneumatic version



Measuring range:	-0.03 ... -1 to 0.4 ... 100 bar
Accuracy:	0.015 ... 0.008 %
Medium:	Non-corrosive gases
Special feature:	Patented system for fast piston-cylinder exchange
Data sheet:	CT 31.01

## CPB5800

### Hydraulic version with dual-range piston-cylinder systems

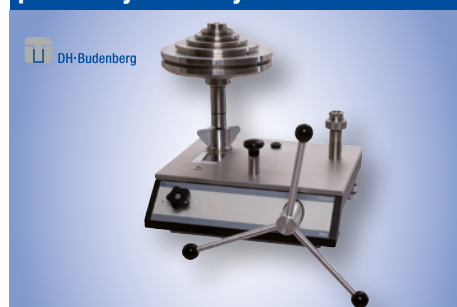

Measuring range:	1 ... 120 to 1 ... 1,400 bar
Accuracy:	0.015 ... 0.006 %
Medium:	Operating fluid or others on request
Special feature:	<ul style="list-style-type: none"> <li>■ Dual-range piston-cylinder systems with fully automated changing between ranges</li> <li>■ Instrument base can also be combined with the CPS5000 piston-cylinder system</li> </ul>
Data sheet:	CT 31.11

## CPB5600DP

### Differential pressure version



Measuring range:	0.03 ... 2 to 25 ... 1,600 bar
Accuracy:	0.015 ... 0.008 %
Medium:	Non-corrosive gases or special oil
Special feature:	Two complete pressure balances within one case for real differential pressure measurements under static pressure
Data sheet:	CT 31.56

## CPB5000HP

### High-pressure version



Measuring range:	25 ... 2,500 to 25 ... 5,000 bar
Accuracy:	0.025 ... 0.02 %
Medium:	Special oil
Special feature:	Robust instrument base with integrated high-pressure generation
Data sheet:	CT 31.51

## CPS5000

### Hydraulic single-range piston-cylinder systems

Special feature:	<ul style="list-style-type: none"> <li>■ for the highest demands on accuracy and performance</li> <li>■ Can be combined with the CPB5800 instrument base</li> </ul>
Data sheet:	CT 31.01

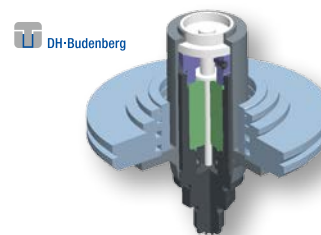

# Pressure balances, high-end version

**High-accuracy and powerful primary standards with excellent operating characteristics, based on the physical principle of Pressure = Force/Area**

The direct measurement of the pressure ( $p = F/A$ ), as well as the use of high-quality materials enable this small measurement uncertainty, in conjunction with an excellent long-term stability (recommended recalibration cycle of five years in accordance with the German Calibration Service DKD/DAkkS).

Furthermore, an automatic mass handling system and pressure generation ensures fully-automated calibration. The pressure balance has therefore been used for years in factory and calibration laboratories in industry, national institutes and research laboratories, and also in production by sensor and transmitter manufacturers.

## CPB6000

**Highest-accuracy primary standard**



Measuring range:	4 ... 5,000 bar
Accuracy:	0.0035 ... 0.0015 %
Medium:	Dry, clean air, nitrogen or special oil
Special feature:	Different instrument variants for the highest demands
Data sheet:	CT 32.01

## CPB6000DP

**Primary standard for differential pressure**



Measuring range:	30 ... 800 bar
Accuracy:	0.005 ... 0.002 %
Medium:	Non-corrosive gases
Special feature:	For differential pressure measurements from 10 Pa to 800 bar
Data sheet:	CT 32.02

## CPB8000

**Automatic primary standard**



Measuring range:	<ul style="list-style-type: none"> <li>■ 500 ... 5,000 bar</li> <li>■ Others on request</li> </ul>
Accuracy:	0.005 ... 0.003 %
Medium:	<ul style="list-style-type: none"> <li>■ Sebacate oil</li> <li>■ Others on request</li> </ul>
Special feature:	Automated calibration of the highest-accuracy pressure sensors, integrated pressure generation
Data sheet:	CT 32.03

## CPD8000

**Digital pressure balance**



Measuring range:	1 ... 500 bar (abs. and rel.)
Accuracy:	0.005 ... 0.002 %
Medium:	Non-corrosive, dry gases
Special feature:	unique operating principle, ideal for automatic calibrations, no mass handling needed
Data sheet:	CT 32.04

# Accessories for pressure balances

## CPU5000

### CalibratorUnit



- Compact computer for use with a pressure balance
- Calculation of pressure ↔ mass load

Data sheet: CT 35.01

## Correction of the environmental conditions to achieve the best possible accuracies

### CalibratorUnit CPU5000

Auxiliary device for calibrations of dead weight testers for the highest accuracy

The specified accuracy of pressure balances is valid under reference conditions, i.e. ambient temperature 20 °C, atmospheric pressure 1,013 mbar, relative air humidity 40 % and for a specific installation location with a local gravitational acceleration. For ambient conditions that deviate from these, if required, corrections must be made.

$$p_e = \left[ \frac{m \cdot \left( 1 - \frac{\rho_l}{\rho_m} \right) \cdot g_l + \sigma \cdot c}{A \cdot \left[ 1 + (\alpha + \beta) \cdot (t - 20) + \lambda_{p_e} \right]} + (\rho_{F1} - \rho_l) \cdot g_l \cdot \Delta h \right] \cdot 10^{-5}$$



### Description

The resulting pressure for a calibration with a pressure balance is influenced by environmental factors and can be corrected through complex mathematical calculations. The CPU5000 CalibratorUnit is a compact computer, with which all critical environmental parameters can be captured and automatically corrected. Furthermore, it offers the possibility to supply electrical pressure transmitters with voltage, and to display their output signals, as well as an automatic capture of the piston position for the display of the float position.

# Reference thermometers

## Conventional contact thermometers

Due to the excellent stability and the geometrical conformance, these standard thermometers are ideally suited to applications in industrial laboratories. Here simple comparative calibrations can be carried out in baths, in tube furnaces and in dry-well calibrators.

The advantage of these reference thermometers is the wide temperature range, and with this, their flexible operation. Furthermore, with their low drift, a long service life is ensured.

### CTP1000

#### Platinum resistance thermometer



Measuring range: -100 ... +670 °C

Stability: < 40 mK after 100 h at 660 °C

Dimensions: Ø 6.35 mm, l = 450 mm

Special feature: ■ 4-wire connection  
■ Ends stripped and tin-coated

Data sheet: CT 61.10

### CTP2000

#### Platinum resistance thermometer



Measuring range: -200 ... +450 °C

Stability: < 50 mK after 100 h at 450 °C

Dimensions: Ø 4 mm, l = 500 mm

Special feature: ■ 4-wire connection  
■ Ends with 4 mm banana plug

Data sheet: CT 61.10

### CTP5000

#### Reference thermometer



Measuring range: -196 ... +660 °C

Probe type: Pt100, Pt25

Dimensions: Depending on version

Special feature: Flying leads, DIN connector or SMART connector

Data sheet: CT 61.20

### CTP9000

#### Thermocouple



Measuring range: 0 ... 1,300 °C

Thermocouple: Type S per IEC 584, class 1

Dimensions: Ø 7 mm, l = 1,500 mm

Special feature: ■ Cold junction optional  
■ 450 mm cable  
■ Ends with 4 mm banana plug

Data sheet: CT 61.10

# Hand-helds

## Portable measuring and calibration instruments for mobile use

For these portable measuring instruments there are various designs of thermometers available. They are therefore particularly suitable as test instruments for a wide variety of fields such as sterile process technology, machine building, etc.

Furthermore, depending on the version, functions such as a data logger and a serial interface are available, so that immediate on-site measurements can be made and documented, and with this, the data can also be simultaneously archived.

### CTR1000

#### Infrared hand-held thermometer



Measuring range:	-60 ... +1,000 °C
Accuracy:	2 K or 2 % of measured value
Special feature:	Thermocouple connection (optional)
Data sheet:	CT 55.21

### CTH6200

#### Hand-held thermometer



Measuring range:	-50 ... +250 °C
Accuracy:	< 0.2 K/opt. < 0.05 K
Probe type:	Pt100
Special feature:	Integrated data logger
Data sheet:	CT 51.01

### CTH6300

#### Hand-held thermometer



Measuring range:	-200 ... +1.500 °C
Accuracy:	0.1K ... 1 K
Probe type:	Pt100, TC
Special feature:	2 channels (optional)
Data sheet:	CT 51.05

### CTH6500

#### Hand-held thermometer



Measuring range:	-200 ... +1,760 °C
Accuracy:	0.03 ... 0.2 K
Probe type:	Pt100, TC
Special feature:	Ex version (optional)
Data sheet:	CT 55.10

### CTH7000

#### Hand-held thermometer



Measuring range:	-200 ... +962 °C
Accuracy:	0.015 K
Probe type:	Pt100, Pt25 and NTC
Special feature:	Integrated data logger
Data sheet:	CT 55.50

# Portable temperature calibrators

## Electronic controllers which automatically, quickly and dryly supply a temperature

Due to the high reliability, accuracy and simple operation, this type of instrument is particularly suitable as a factory/working standard for the automatic testing and/or calibration of temperature measuring instruments of all types.

A major advantage is offered by the large sleeve diameters and the fast, stable temperature control, since, as a result of these characteristics, the time for calibration can be used very effectively.

### CTI5000

#### Infrared calibrator



Measuring range:	50 ... 500 °C
Accuracy:	1 K
Stability:	0.1 ... 0.4 K
Special feature:	Large diameter of measuring surface
Data sheet:	CT 41.42

### CTD9100-375

#### Compact temperature dry-well calibrator



Measuring range:	$t_{amb} \dots 375$ °C
Accuracy:	0.5 ... 0.8 K
Stability:	0.05 K
Immersion depth:	100 mm
Data sheet:	CT 41.32

### CTD9100

#### Temperature dry-well calibrator



Measuring range:	-55 ... +650 °C
Accuracy:	0.15 ... 0.8 K
Stability:	0.01 ... 0.05 K
Immersion depth:	150 mm
Data sheet:	CT 41.28

### CTM9100-150

#### Multi-function calibrator



Measuring range:	-35 ... +165 °C depending on the application
Accuracy:	0.3 ... 1 K depending on the application
Immersion depth:	150 mm
Special feature:	Application as dry-well calibrator, micro calibration bath, infrared calibrator and surface calibrator
Data sheet:	CT 41.40

### CTD9300

#### Temperature dry-well calibrator



Measuring range:	-35 ... +650 °C
Accuracy:	0.1 ... 0.65 K
Stability:	0.01 ... 0.1 K
Immersion depth:	150 mm
Data sheet:	CT 41.38

### CTD9100-1100

#### High-temperature dry-well calibrator



Measuring range:	200 ... 1,100 °C
Accuracy:	3 K
Stability:	0.3 K
Immersion depth:	225 mm
Data sheet:	CT 41.29

# Calibration baths

**Electronic controllers which automatically, quickly and with the help of a liquid supply a temperature**

Due to the high reliability, accuracy and exceptional homogeneity in the measuring chamber, this type of instrument is particularly suitable as a factory/working

standard for the automatic testing and/or calibration of the widest range of temperature sensors - independent of diameter. A special micro calibration bath design enables on-site applications.

## CTB9100

Micro calibration bath



Measuring range:	-35 ... +255 °C
Accuracy:	0.2 ... 0.3 K
Stability:	±0.05 K
Special feature:	<ul style="list-style-type: none"> <li>■ Short heating and cooling times</li> <li>■ Easy to use</li> </ul>
Data sheet:	CT 46.30

## CTB9400

Calibration bath,  
medium measuring range



Measuring range:	28 ... 300 °C
Stability:	0.02 K
Immersion depth:	200 mm
Medium:	Water, oil or similar media
Data sheet:	CT 46.20

## CTB9500

Calibration bath,  
low measuring range



Measuring range:	-45 ... +200 °C
Stability:	0.02 K
Immersion depth:	200 mm
Medium:	Water, oil or similar media
Data sheet:	CT 46.20

# Resistance bridges

**Electronic resistance bridges measure resistances with highest accuracy**

With the help of a standard resistance, resistance bridges measure resistance ratios with highest accuracy that may be indicative of the temperature, among other things. Thanks to their high accuracy, these instruments are not only used in the field of temperature measurement, but also in electrical laboratories.

## CTR5000

Precisions thermometer



Measuring range:	-200 ... +962 °C
Accuracy:	0.01 K, optional 0.005 K
Probe type:	Pt100, Pt25
Special feature:	Integrated data logger (optional), up to 64 channels
Data sheet:	CT 60.20

# Hand-helds, calibrators

## Portable measuring and calibration instruments for mobile use

Due to unparalleled performance characteristics and low measurement uncertainties these instruments are used for calibration in industry (laboratories, production, workshops), in calibration service companies and in quality assurance.

### CEP1000

#### Hand-held loop calibrator



Measuring range: 0 ... 24 mA, 0 ... 28 V  
 Accuracy: 0.015 %  
 Special feature: Simulates, powers and measures 2-wire transmitters  
 Data sheet: CT 81.01

### CEP3000

#### Hand-held temperature calibrator



Measuring range: ■ -10 ... +75 mV, 5 ... 3,200 Ω  
 ■ -200 ... +1,200 °C (type J)  
 ■ -200 ... +800 °C (Pt100)  
 Accuracy: 0.4 °C (type J), 0.33 °C (Pt100)  
 Special feature: Measurement and simulation of thermocouples and resistance thermometers  
 Data sheet: CT 82.01

### CEP6000

#### Hand-held multifunction calibrator



Measuring range: ■ 0 ... 24 mA, 0 ... 30 V, 5 ... 4,000 Ω  
 ■ 2 CPM ... 10 kHz  
 ■ -210 ... +1,200 °C (type J)  
 ■ -200 ... +800 °C (Pt100)  
 Accuracy: 0.015 %  
 Special feature: Measurement and simulation of thermocouples, resistance thermometers, resistance, current, voltage, frequency, pulse and pressure  
 Data sheet: CT 83.01

### CED7000

#### High-precision process calibrator



Measuring range: ■ 0 ... 100 mA, 0 ... 100 V, 5 ... 4,000 Ω  
 ■ -210 ... +1,200 °C (type J)  
 ■ -200 ... +800 °C (Pt100)  
 Accuracy: 0.003 %  
 Special feature: High-precision measurement and simulation of thermocouples and resistance thermometers, resistance, current, voltage and pressure  
 Data sheet: CT 85.51

### Pascal ET

#### Hand-held multi-function calibrator



Measuring range: ■ 0 ... 100 mA, 0 ... 80 V, 5 ... 10,000 Ω  
 ■ 0 ... 50 kHz  
 ■ -190 ... +1,200 °C (type J)  
 ■ -200 ... +850 °C (Pt100)  
 Accuracy: 0.008 %  
 Special feature: ■ Large display with touch-screen  
 ■ Integrated data logger and calibration function  
 ■ Measurement and simulation of temperature, current, voltage, resistance, frequency, pressure  
 Data sheet: CT 18.52

# Accessories

## From single components to complete kits

For pressure as a measurement parameter, we offer from thread adapters, through sensors to complete service kits - all you could need for calibration.

Customer-specific drilled inserts, silicone oil suited for calibration in micro calibration baths and interface cables complete the product portfolio for temperature.

## Hardware

### Pressure



## Hardware

### Temperature



## Software

### Pressure and temperature



# Calibration systems

## Turnkey, customer-specific systems and installations with corresponding software

From the extensive product programme an integrated solution can be designed with the required degree of automation. The major advantage with this is the experience with the well-proven application of measuring technology in WIKA's own accredited laboratories and manufacturing plants.

### Adjustment and calibration benches



Measuring range: ■ 1 ... 400 bar pneumatic  
 ■ 10 ... 1,600 bar hydraulic  
 Accuracy: Depending on the measuring devices used  
 Medium: Compressed air, nitrogen, oil or water  
 Special feature: Provision of pressure in workshops and laboratories

### Mobile calibration benches



Measuring range: Customer-specific  
 Accuracy: Down to 0.008 %  
 Medium: Compressed air, nitrogen, oil or water  
 Special feature: Complete turnkey system

### Inspection systems



Measuring range: Customer-specific  
 Accuracy: Down to 0.008 %  
 Medium: Compressed air, nitrogen, oil or water  
 Special feature: Measurement parameters pressure, temperature and electrical measurement parameters

### Automated pressure calibration systems



Measuring range: Customer-specific  
 Accuracy: Down to 0.008 %  
 Medium: Compressed air, nitrogen, oil or water  
 Special feature: Complete turnkey system

### Automated temperature calibration systems



Measuring range: Customer-specific  
 Stability: Up to 0.001 K  
 Medium: Water, alcohol, silicone oil or salt  
 Special feature: Complete turnkey system

# Complete solutions

Simple checking or professional calibration

## CPH6000 and CPP30

Calibration of a process transmitter



- Pressure generation with the pneumatic hand test pump CPP30
- Reading of the electrical signal of the process transmitter via the electrical input of the CPH6000
- Recording of the calibration in the CPH6000 and later evaluation on a PC in conjunction with the EasyCal software

## CPH6600

Calibration of a process transmitter



- Pressure generation with the integrated electrical pump of the CPH6600
- Reading of the electrical signal of the process transmitter via the electrical input of the CPH6600

## CPH6400 and CPP5000-X

High-pressure calibration



- Pressure generation with the hydraulic high-pressure pump CPP5000-X
- Reading of the electrical signal of the calibration item via a digital indicator
- Online acquisition of the calibration data and generation of calibration certificates in conjunction with the PrintCal software

# Operating principle

## Pressure balances

**Mechanical dead weight testers (primary standards), based on the physical principle Pressure = Force/Area.**

Mass pieces placed on the top of a piston-cylinder system are the source of a precisely defined force. By producing a certain pressure (counter pressure) inside the pressure balance by using e.g. the integrated hand pump, an equilibrium is achieved. In the state of equilibrium the pressure is high enough, that the mass pieces, incl. the free-running piston of the piston-cylinder system, are floating, which will lead to a very accurate pressure at the test port.

The resource needed in this case is a pressure supply, but only for pneumatic applications > 10 bar, or a vacuum source for negative pressure versions.

**Benefit:** Large measuring range coverage is possible, long recalibration intervals and stand-alone operation.

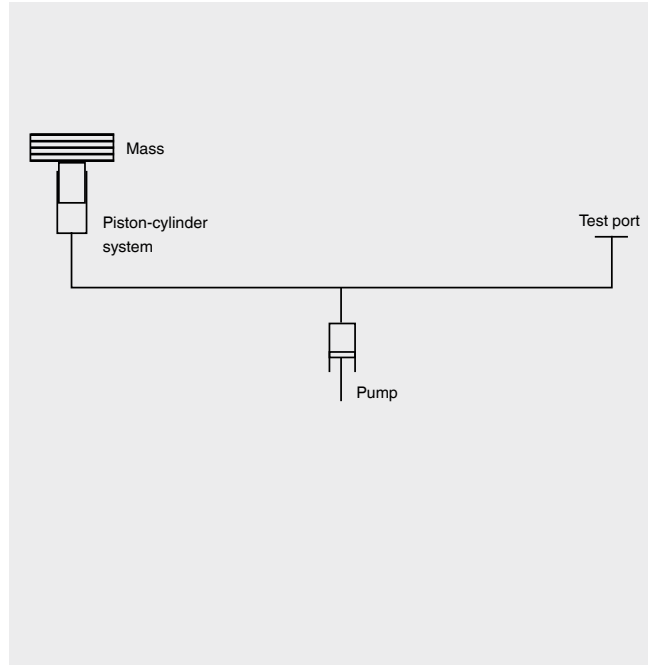

## Digital pressure balances

**Digital pressure balances require no mass-disc handling**

In contrast to the mechanical dead weight testers, with digital pressure balances, no mass discs are used. Via a piston-cylinder unit, the applied pressure,  $P$ , is converted into a Force,  $F$ , ( $F = p \times A$ ), which is then "weighed" ( $m = F/g$ ), i.e. the cylinder pressure is directed onto a load cell which works on the principle of electromagnetic force compensation.

This unique measuring principle of digital pressure balances in combination with pressure controllers enables a fully-automatic calibration with the highest accuracy. With the integrated measurement module for environmental conditions, the reference value is automatically corrected.

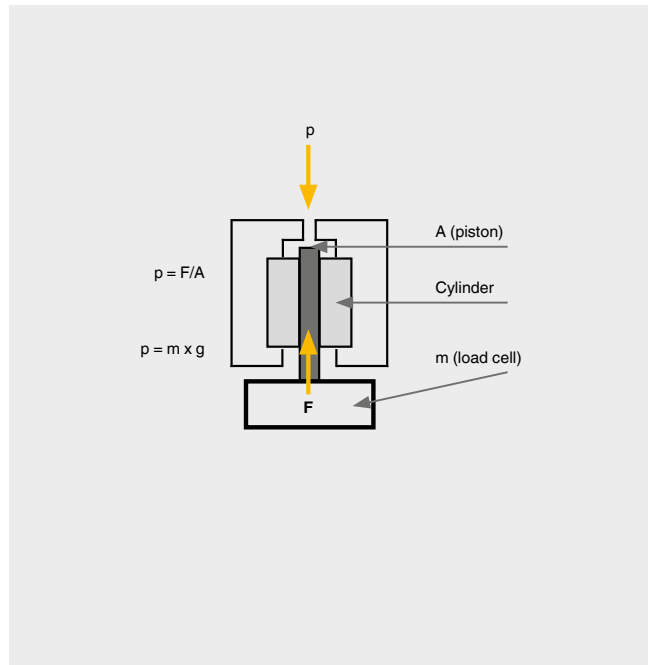

### Pressure sensor and pressure sensor with display or pressure indicator

**Electrical measuring systems which convert pressure into an electrical signal and optionally visualise it.**

Pressure sensors and indicators convert the physical property of pressure into a proportional electrical signal which will be accessible via analogue or digital interface for further use or processing. Indicators usually offer, in addition to displaying the signal in various pressure units, the possibility of using diverse implemented functions (MIN/MAX memory, etc.).

The resource needed in this case is a power supply.

**Benefit:** Pressure signal available via electrical interface and, if required, displayed visually.

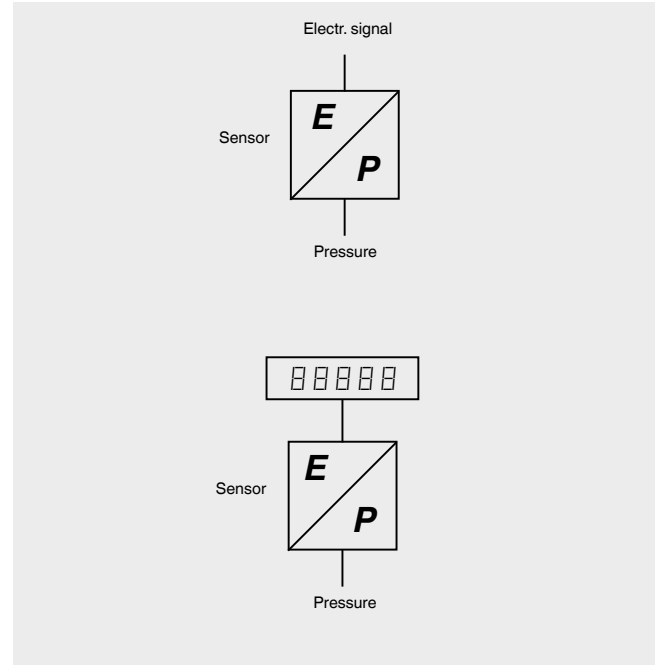

### Pneumatic pressure controller

**Electronic controllers which quickly and automatically provide a pressure based on a supply pressure.**

**Pneumatic:** An entered set point, set via keypad or electrical interface, is quickly and accurately made available at the output (test port), using a control unit; consisting of a valve unit and a precision pressure sensor. This is achieved by appropriately regulating a connected pneumatic pressure supply (> 100 %). To control pressure values lower than the ambient air pressure, a vacuum source must also be connected to the device.

**Hydraulic:** Here, a fluid medium (e.g.: distilled water) is

compressed by the control unit. This is done by a closed-loop control circuit based on a pneumatic primary control circuit (12 ... 30 bar) and a mechanical pressure multiplier with a hydraulic output (secondary circuit).

The resources needed in this case are, in addition to a power supply, a pressure supply and if needed a vacuum source.

**Advantage:** Fast provision of pressure and full automation via electrical interface.

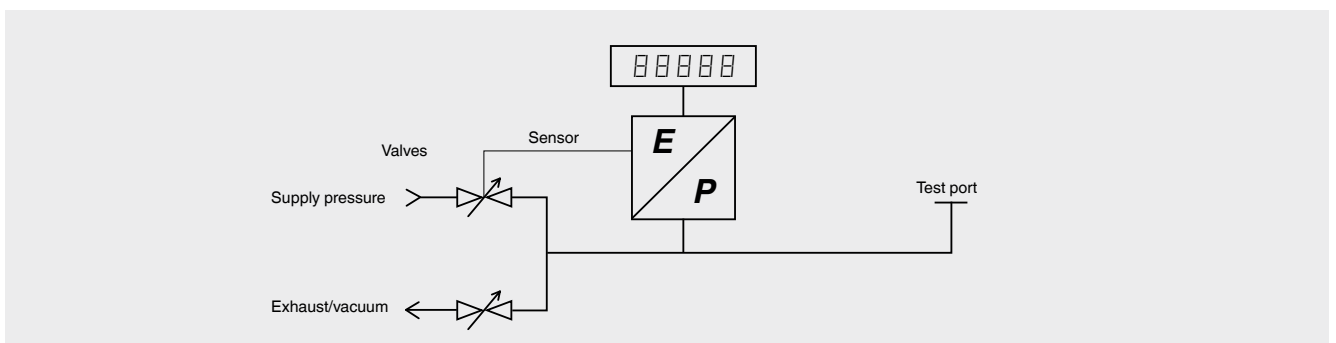

# Complete solutions

Simple checking or professional calibration

## CTH6200

Online temperature measurement



Optional: With data logging and subsequent transfer of the logged data to a PC.

## CEP6100

## CTB9100

On-site calibration of a temperature sensor



- Stable control of temperature with the CTB9100 micro calibration bath
- Accurate measurement of temperature with the logging CEP6100 hand-held multi-function calibrator
- Transfer of the calibration data to a PC incl. generation of the calibration certificate

# Operating principle

## Dry-well calibrators

**Electronic controllers which automatically, quickly and dryly supply a temperature.**

With these instruments, a controllable temperature is produced within a solid block, with the aim of calibrating thermometers in the bores within this block.

A temperature dry-well calibrator consists, at the very least, of a solid block, a temperature control unit for the block and a calibrator thermometer (internal reference) with a display for determining the block temperature.

## Calibration baths

**Electronic controllers which automatically, quickly and with the help of a liquid supply a temperature**

With these instruments, a controllable temperature is produced within a liquid tank, with the aim of calibrating thermometers.

A micro calibration bath consists, at the very least, of a liquid tank, a correctly selected liquid for the tank and a calibrator thermometer (internal reference) with a display for determining the tank temperature.

The components mentioned above are combined as a compact instrument.

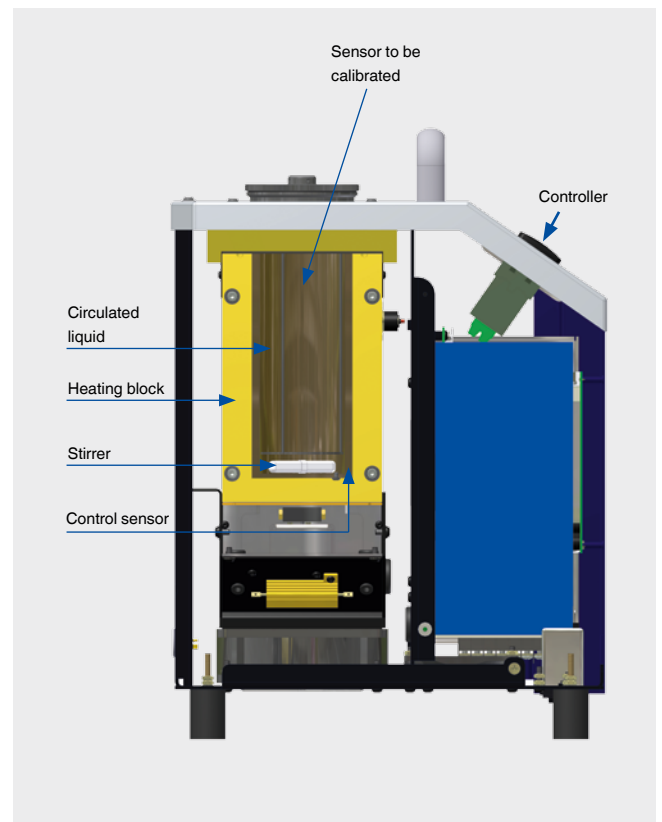
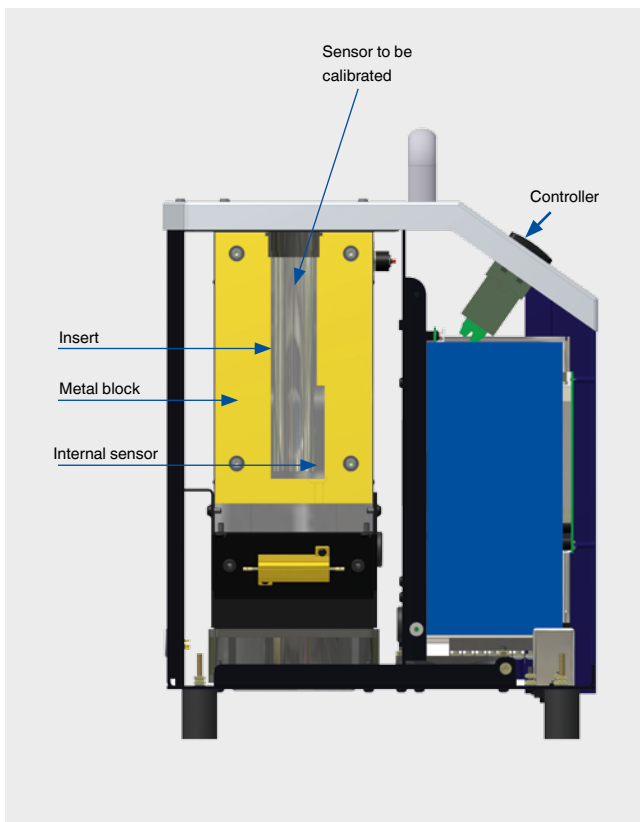

# Calibration services

Our calibration laboratory for pressure has been accredited since 1982 and for temperature since 1992 in accordance with DIN EN ISO/IEC 17025.

-1 ... +5,000 bar



D-K-15105-01-00 → Measurement parameter pressure

**We calibrate your pressure measuring instruments quickly and precisely:**

- in the range -1 ... +5,000 bar
- using high-precision reference standards (pressure balances) and working standards (precise electrical pressure measuring instruments)
- with an accuracy from 0.004 ... 0.01 % of reading depending on the pressure range
- in accordance with the directives DIN EN 837, DKD/DAkkS R 6-1, EA 10/03 or EA 10/17

-196 ... +1,200 °C



D-K-15105-01-00 → Measurement parameter temperature

**We calibrate your temperature measuring instruments quickly and precisely:**

- in the range -196 ... +1,200 °C
- in calibration baths, tube furnaces or at fixed points using appropriate reference thermometers
- with an accuracy from 2 mK ... 1.5 K depending on temperature and the applied procedure
- in accordance with the appropriate DKD/DAkkS and EA directives

On-site calibration



D-K-15105-01-00

In order to have the least possible impact on the production process, we offer you a time-saving, on-site DKD/DAkkS calibration throughout Germany.

**We calibrate your pressure and temperature measuring instruments quickly and precisely:**

- in our calibration van or on your workbench
- Factory test certificates for temperature from -35 ... +650 °C
- with a DKD/DAkkS accreditation for pressure
  - in the range from -1 ... +1,600 bar
  - with accuracies between 0.01 % and 0.05 % of FS for the standard used

Consulting and training



If you are planning to expand your instrumentation, we will gladly lend our experience in the selection of the appropriate solution.

In collaboration with our team of calibration technology experts, we develop tailor-made solutions.

If required, also as a turnkey plug and play system. On-site commissioning as well as the training of the operator is naturally included.

Our calibration courses are individually matched to your requirements and needs.

Thus we can set the topics for the theory as well as the practice of calibration technology.

# WIKA worldwide

## Europe

**Austria**  
WIKA Messgerätevertrieb  
Ursula Wiegand GmbH & Co. KG  
Perfektastr. 83  
1230 Vienna  
Tel. +43 1 8691631  
Fax: +43 1 8691634  
info@wika.at  
www.wika.at

**Belarus**  
WIKA Belarus  
Ul. Zaharova 50B, Office 3H  
220088 Minsk  
Tel. +375 17 2945711  
Fax: +375 17 2945711  
info@wika.by  
www.wika.by

**Benelux**  
WIKA Benelux  
Industrial estate De Berk  
Newtonweg 12  
6101 WX Echt  
Tel. +31 475 535500  
Fax: +31 475 535446  
info@wika.nl  
www.wika.nl

**Bulgaria**  
WIKA Bulgaria EOOD  
Akad.Ivan Geshov Blvd. 2E  
Business Center Serdika, office 3/104  
1330 Sofia  
Tel. +359 2 82138-10  
Fax: +359 2 82138-13  
info@wika.bg  
www.wika.bg

**Croatia**  
WIKA Croatia d.o.o.  
Hrastovicka 19  
10250 Zagreb-Lucko  
Tel. +385 1 6531-034  
Fax: +385 1 6531-357  
info@wika.hr  
www.wika.hr

**Finland**  
WIKA Finland Oy  
Melkonkatu 24  
00210 Helsinki  
Tel. +358 9 682492-0  
Fax: +358 9 682492-70  
info@wika.fi  
www.wika.fi

**France**  
WIKA Instruments s.a.r.l.  
Parc d'Affaires des Bellevues  
8 rue Rosa Luxembourg  
95610 Eragny-sur-Oise  
Tel. +33 1 343084-84  
Fax: +33 1 343084-94  
info@wika.fr  
www.wika.fr

**Germany**  
WIKA Alexander Wiegand SE & Co. KG  
Alexander-Wiegand-Str. 30  
63911 Klingenberg  
Tel. +49 9372 132-0  
Fax: +49 9372 132-406  
info@wika.de  
www.wika.de

**Italy**  
WIKA Italia Srl & C. Sas  
Via G. Marconi 8  
20020 Arese Milano  
Tel. +39 02 93861-1  
Fax: +39 02 93861-74  
info@wika.it  
www.wika.it

**Poland**  
WIKA Polska spółka z ograniczoną  
odpowiedzialnością sp. k.  
ul. Legska 29/35  
87-800 Wloclawek  
Tel. +48 54 230110-0  
Fax: +48 54 230110-1  
info@wikapolska.pl  
www.wikapolska.pl

**Romania**  
WIKA Instruments Romania S.R.L.  
050897 Bucuresti  
Calea Rahovei Nr. 266-268  
Corp 61, Etaj 1  
Tel. +40 21 4048327  
Fax: +40 21 4563137  
m.anghel@wika.ro  
www.wika.ro

**Russia**  
WIKA MERA  
Wjatskaya Str. 27, Building 17  
Office 205/206  
127015 Moscow  
Tel. +7 495-648018-0  
Fax: +7 495-648018-1  
info@wika.ru  
www.wika.ru

**Serbia**  
WIKA Merna Tehnika d.o.o.  
Sime Solaje 15  
11060 Belgrade  
Tel. +381 11 2763722  
Fax: +381 11 753674  
info@wika.rs  
www.wika.rs

**Spain**  
Instrumentos WIKA S.A.U.  
C/Josep Carner, 11-17  
08205 Sabadell Barcelona  
Tel. +34 933 9386-30  
Fax: +34 933 9386-66  
info@wika.es  
www.wika.es

**Switzerland**  
MANOMETER AG  
Industriestrasse 11  
6285 Hitzkirch  
Tel. +41 41 91972-72  
Fax: +41 41 91972-73  
info@manometer.ch  
www.manometer.ch

**Turkey**  
WIKA Instruments Istanbul  
Basinc ve Sicaklik Ölçme Cihazlari  
Ith. Ihr. ve Tic. Ltd. Sti.  
Bayraktar Bulvarı No. 17  
34775 Şerifali-Yukan Dudullu - Istanbul  
Tel. +90 216 41590-66  
Fax: +90 216 41590-97  
info@wika.com.tr  
www.wika.com.tr

**Ukraine**  
TOV WIKI Prylad  
M. Raskovoy Str. 11, A  
PO 200  
02660 Kyiv  
Tel. +38 044 4968380  
Fax: +38 044 4968380  
info@wika.ua  
www.wika.ua

**United Kingdom**  
WIKA Instruments Ltd  
Merstham, Redhill RH13LLG  
Tel. +44 1737 644-008  
Fax: +44 1737 644-403  
info@wika.co.uk  
www.wika.co.uk

## North America

**Canada**  
WIKA Instruments Ltd.  
Head Office  
3103 Parsons Road  
Edmonton, Alberta, T6N 1C8  
Tel. +1 780 4637035  
Fax: +1 780 4620017  
info@wika.ca  
www.wika.ca

**Mexico**  
Instrumentos WIKI Mexico  
S.A. de C.V.  
Vienna 20 Ofina 301  
Col. Juarez, Del. Cuauhtemoc  
06600 Mexico D.F.  
Tel. +52 55 50205300  
Fax: +52 55 50205300  
ventas@wika.com  
www.wika.com.mx

**USA**  
WIKI Instrument, LP  
1000 Wiegand Boulevard  
Lawrenceville, GA 30043  
Tel. +1 770 5138200  
Fax: +1 770 3385118  
info@wika.com  
www.wika.com

WIKI Process Solutions, LP  
950 Hall Court  
Deer Park, TX 77536  
Tel. +1 713 47500-22  
Fax: +1 713 47500-11  
info@wikahouston.com  
www.wika.com

Mensor Corporation  
201 Barnes Drive  
San Marcos, TX 78666  
Tel. +1 512 3964200-15  
Fax: +1 512 3961820  
sales@mensor.com  
www.mensor.com

## Latin America

**Argentina**  
WIKI Argentina S.A.  
Gral. Lavalle 3568  
(B1603AUH) Villa Martelli  
Buenos Aires  
Tel. +54 11 47301800  
Fax: +54 11 47610050  
info@wika.com.ar  
www.wika.com.ar

**Brazil**  
WIKI do Brasil Ind. e Com. Ltda.  
Av. Ursula Wiegand, 03  
CEP 18560-000 Iperó - SP  
Tel. +55 15 34599700  
Fax: +55 15 32661650  
vendas@wika.de  
www.wika.com.br

**Chile**  
WIKI Chile S.p.A.  
Av. Coronel Pereira 72  
Oficina 101  
Las Condes - Santiago de Chile  
Tel. +56 2 365-1719  
info@wika.cl  
www.wika.cl

**Colombia**  
Instrumentos WIKI Colombia S.A.S.  
Dorado Plaza,  
Avenida Calle 26 No. 85D - 55  
Local 126 y 126 A  
Bogotá - Colombia  
Tel. +57 1 744 3455  
info@wika.co

## Asia

**Azerbaijan**  
WIKI Azerbaijan LLC  
Caspian Business Center  
9th floor 40 J.Jabbarli str.  
AZ1065 Baku  
Tel. +994 12 49704-61  
Fax: +994 12 49704-62  
info@wika.az

**China**  
WIKI International Trading Shanghai  
Co., Ltd.  
A2615, NO.100, Zunyi Road  
Changning District  
Shanghai 200051  
Tel. +86 21 538525-72  
Fax: +86 21 538525-75  
info@wika.cn  
www.wika.com.cn

WIKI Instrumentation Suzhou Co., Ltd.  
81, Ta Yuan Road, SND  
Suzhou 215011  
Tel. +86 512 6878 8000  
Fax: +86 512 6878 0300  
info@wika.cn  
www.wika.com.cn

**India**  
WIKI Instruments India Pvt. Ltd.  
Village Kesnard, Wagholi  
Pune - 412 207  
Tel. +91 20 66293-200  
Fax: +91 20 66293-325  
sales@wika.co.in  
www.wika.co.in

**Japan**  
WIKI Japan K. K.  
MG Shibaura Bldg, 6F  
1-8-4, Shibaura, Minato-ku  
Tokyo 105-0023  
Tel. +81 3 5439-6673  
Fax: +81 3 5439-6674  
info@wika.co.jp  
www.wika.co.jp

**Kazakhstan**  
TOO WIKI Kazakhstan  
Raimbekstr. 169, 3rd floor  
050050 Almaty  
Tel. +7 727 2330848  
Fax: +7 727 2789905  
info@wika.kz  
www.wika.kz

**Korea**  
WIKI Korea Ltd.  
569-21 Gasan-dong, Geumcheon-gu  
Seoul 153-771 Korea  
Tel. +82 2 86905-05  
Fax: +82 2 86905-25  
info@wika.co.kr  
www.wika.co.kr

**Malaysia**  
WIKI Instrumentation M Sdn. Bhd.  
No. 27 & 29 Jalan Puteri 5/20  
Bandar Puteri Puchong  
47100 Puchong, Selangor  
Tel. +60 3 806310-80  
Fax: +60 3 806310-70  
info@wika.com.my  
www.wika.com.my

**Philippines**  
WIKI Instruments Philippines, Inc.  
Unit 102 Skyway Twin Towers  
351 Capt. Henry Javier St.  
Bgy. Oranbo, Pasig City 1600  
Tel. +63 2 234-1270  
Fax: +63 2 695-9043  
danny.redica@wika.com  
www.wika.com.ph

**Singapore**  
WIKI Instrumentation Pte. Ltd.  
13 Kian Teck Crescent  
628878 Singapore  
Tel. +65 6844 5506  
Fax: +65 6844 5507  
info@wika.com.sg  
www.wika.com.sg

**Taiwan**  
WIKI Instrumentation Taiwan Ltd.  
Min-Tsu Road, Pinjen  
32451 Taoyuan  
Tel. +886 3 420 6052  
Fax: +886 3 490 0080  
info@wika.com.tw  
www.wika.com.tw

**Thailand**  
WIKI Instrumentation Corporation  
Thailand Co., Ltd.  
850/7 Ladkrabang Road, Ladkrabang  
Bangkok 10520  
Tel. +66 2 32668-76  
Fax: +66 2 32668-74  
info@wika.co.th  
www.wika.co.th

## Africa / Middle East

**Egypt**  
WIKI Near East Ltd.  
Villa No. 6, Mohamed Fahmy  
Elmohdar St. - of Eltayaran St.  
1st District - Nasr City - Cairo  
Tel. +20 2 240 13130  
Fax: +20 2 240 13113  
info@wika.com.eg  
www.wika.com.eg

**Namibia**  
WIKI Instruments Namibia Pty Ltd.  
P.O. Box 31263  
Pionierspark  
Windhoek  
Tel. +26 4 61238811  
Fax: +26 4 61233403  
info@wika.com.na  
www.wika.com.na

**South Africa**  
WIKI Instruments Pty. Ltd.  
Gardenview  
Johannesburg 2047  
Tel. +27 11 62100-00  
Fax: +27 11 62100-59  
sales@wika.co.za  
www.wika.co.za

**United Arab Emirates**  
WIKI Middle East FZE  
P.O. Box 17492  
Jebel Ali, Dubai  
Tel. +971 4 8839 090  
Fax: +971 4 8839 198  
info@wika.ae  
www.wika.ae

## Australia

**Australia**  
WIKI Australia Pty. Ltd.  
Unit K, 10-16 South Street  
Rydalmere, NSW 2116  
Tel. +61 2 88455222  
Fax: +61 2 96844767  
sales@wika.com.au  
www.wika.com.au

**New Zealand**  
WIKI Instruments Limited  
Unit 7 / 49 Sainsbury Road  
St Lukes - Auckland 1025  
Tel. +64 9 8479020  
Fax: +64 9 8465964  
info@wika.co.nz  
www.wika.co.nz

**WIKI Alexander Wiegand SE & Co. KG**  
Alexander-Wiegand-Straße 30 · 63911 Klingenberg · Germany  
Tel. +49 9372 132-0 · Fax +49 9372 132-406  
info@wika.de · www.wika.de



Part of your business